

Ordinary level

PHYSICAL EDUCATION AND SPORTS

FOR RWANDAN SCHOOLS

TEACHER'S GUIDE 2

Authors

Edward Kityo

Tom Kibirango

Godfrey Ssempaka



Setting a New Trend in School Books Publishing

MK Publishers (R) Ltd.

Gikondo Industrial Area

B.P : 6810 Kigali

Tel : +250 785250799

Kigali Rwanda

MK Publishers Ltd.

MK Book House

Plot 1187 Kibuye, Kampala - Entebbe Highway

P. O. Box 12385, Kampala-Uganda

Tel: 0414 -269150

Fax : 0414 -341838/269150

Website: www.mkpublishers.com

© **MK Publishers Ltd.** 2017

ISBN : 9970-50-355-3

All rights reserved. No reproduction, copy, transmission of this publication may be made without written permission.

No paragraph of this publication may be reproduced, copied, transmitted or saved without the written permission or in accordance with the provision of Law No. 27/1983 regulating copyrights, or under the terms of licence permitting limited copying issued by the licensing agency in Rwanda.

Any person who undertakes any unauthorised act in relation to this publication may be liable to criminal prosecution and civil claims for damages.

CONTENTS

UNIT 1: MOTOR CONTROL	1
Lesson 1: Movement	2
Unit 2: BODY CONTROL AND BALANCE	7
Lesson 1: Body Control and balance	8
UNIT 3: GYMNASTICS	13
Lesson 1: Gymnastics exercises done on the ground and using apparatuses	14
UNIT 4: ATHLETICS	23
Lesson 1: Running exercises	25
Lesson 2: Hurdles	36
Lesson 3: Jumping Exercises (long jump)	42
Lesson 4 : High Jump - The Fosbury Flop	47
Lesson 5 : Triple Jump	49
Lesson 6 : Throwing Exercises (The Shot Put)	51
Lesson 7 : The Discus	53
Lesson 8 : The javelin	55
UNIT 5: FOOTBALL	59
Lesson 1: Attacking systems	61
Lesson 2: Counter-attack	67
Lesson 3: Harassing the Opponent	70
Lesson 4: Mutual Aid	72
Lesson 5: Heading in Defence	73
Lesson 6: Tackles	76
Lesson 7: Rules in Football	80
Lesson 8: Football drills	84

UNIT 6: VOLLEYBALL	88
Lesson 1: Service	89
Lesson 2: Passing	93
Lesson 3: Defence	95
Lesson 4: Attacking systems and Basic Rules	98
UNIT 7: BASKETBALL	104
Lesson 1: Basketball techniques and tactics	106
Lesson 2 : Systems of Basketball game	111
Lesson 3: Basketball rules and technical gestures	118
Lesson 4: Game situation	122
UNIT 8: HANDBALL	124
Lesson 1: Techniques of attack	125
Lesson 2: Techniques of counterattack	126
Lesson 3: Defensive systems	129
Lesson 4: Handball rules	130
UNIT 9: GOALBALL	134
Lesson 1: Techniques and tactics of goalball	135
UNIT 10: SITTING VOLLEYBALL	141
Lesson 1: Techniques and tactics of playing sitting volleyball	143
UNIT 11: NETBALL	148
Lesson 1: Techniques of Netball	150
Lesson 2: Tactics of Netball	158
Lesson 3: Basic Rules of Netball	162

INTRODUCTION

Physical Education is distinguished from other curricular areas by its primary focus on the body and on Physical experience. It is an integral part of the education process, without which the education of the learner is incomplete. Through a diverse range of experiences providing regular, challenging physical activity, the balance and harmonious development and general well-being of the learner is fostered.

Through Physical Education, the learner can experience the joy of physical exertion and the satisfaction of achievement while developing skills and positive attitudes that enhance self-esteem. Physical education provides opportunities to develop desirable personal and social attributes. These include;

- the concept of fair play.
- the acceptance of success and failure, and
- promotion of a healthy life-style.

Physical education, as an integral part of the total competency based curriculum, provides vital opportunities for the physical, social, emotional and intellectual development of the learner.

This book is written in a way that engages learners to be dynamic and aligned to the future employment needs of the nation and the global economy and to have standards comparable with the highest internationally in terms of competencies, knowledge and skills.

They learn how to plan, perform and evaluate actions, ideas and performances to improve their quality and effectiveness. Through this process, learners discover their aptitudes, abilities and preference, and make choices about how to engage in life long physical activity and to live a healthy life.

Activity in physical education programmes may emphasise self improvement, participation and cooperation rather than winning and losing. Learners learn how to think in different ways to suit a variety of creative, competitive and challenging activities. However, competition can be an element in the learner's intrinsic motivation to do his or her best.

Physical Education and Sports

Physical education and sports, although closely linked, are not synonymous. Sports is formalised physical activity involving competition or challenges against oneself, others or the environment, with an emphasis on winning. It begins with playing and develops through games and challenges. The focus in the physical education curriculum is on the learner's holistic development, stressing personal and social development, physical growth and motor focus on individual improvement and not on winning or being the best.

Physical Education and other areas of the curriculum.

Physical education has many objectives that are developed as the learners engage in other subjects, such as English, Geography, Biology, Music and Mathematics. Learners learning these subjects can also be enriched through a programme of physical education that is broad and balanced. The learners who engage in discussions about the rules

of games or the development of gymnastics sequences are presented with many opportunities for language development.

It is in talking about experience in Physical education, like through instructional language that the learner clarifies ideas. Use the language in physical education lessons to question, direct, explain, suggest, prompt and stimulate the learner to think. In turn, the learner is encouraged to respond by describing, discussing, speculating, explaining and expressing ideas and reactions. Language is important too in helping learners to gain access to and retrieve information about physical activities. The extent, therefore, to which language is an integral part of the teaching and learning process, should be a consistent concern in the planning and implementation of the physical education programme.

Physical Education and Learners with special needs

The Learners with special needs should experience the enjoyment of participation. This helps them to feel comfortable and not discriminated in physical activities. It is important that you encourage their maximum participation.

Handling learners with specific disabilities (All inclusive education). This action handles learners with disabilities. It is referred to as “Specific education”. It involves designing instruction for handicapped learners. These include;

- mentally retarded
- difficulty in hearing
- deaf
- speech impaired
- visually handicapped among others
- lame(physically handicapped)

a) Mentally retarded

If the learner is mildly retarded, he or she is slow to understand directions, follow directions, complete tasks and make progress.

How to help the learner.

You should first understand these learners. They can also learn if supported. However, their learning is at a slow rate and is not at the level of normal mentally functioning learners. Concentrate on fundamental skills and fitness qualities. You should always motivate them and introduce to them the personalised fitness programmes. The pace of learning depends on the gross motor movement that is progressive in nature. Teach them activities through demonstration rather than verbalisation. However, the practice period should be short. This is because they get offtrack easily.

Give them a chance to show off skills they can perform. This makes them enjoy the feeling of accomplishment. Trying out any physical activity should be rewarded. This will encourage them to practices more.

b) Visually handicapped

These can be categorised into two, that is; the partially blind and completely blind. They face a big problem in movement. Try to move in a very dark room to realise the problem faced by a visually impaired learner. This impairment poses movement problems to the learners, it also limits them from participating in certain types of physical activities.

How to help the learner?

Bring the learner into contact with others. The learner can take part in group fitness activities with the assistance of the teacher or other learners. Monitor the movements and help the learner. You should also encourage other learners to help this learner. This learner should carry out specialised physical fitness and movement programmes in which the lack of sight does not prove a difficult task or problem. Rope jumping is a good activity for them. Also use low balance beams, and bench activities. You can touch a part of the learners body to establish his or her correct sequence in movement pattern. Since visually handicapped learners cannot copy or see from other learners or from you what to do, your explanation must be clear and precise. Use a whistle to signal to the class or give instruction.



Blind learner walking with stick

c) The deaf

These are learners who have hearing problems. Since most of the instructions are verbal, a deaf learner is isolated if not catered for. Teaching the deaf is challenging and requires different communication techniques. Many deaf learners have poor speech.

How to help the learner

Written instructions can be used. Visual clues featuring a “do as i do” approach are appropriate. Position the deaf learners near you to increase their opportunities to read the signs and lips and receive facial clues. Avoid long delays for explanation or questions. Hand signals should be used for controlling movement patterns, for example; start, stop, move to an area, sit down and so on.



Deaf learners making sign language

d) The lame

These are learners with a physical impairments. These learners normally move with the help of wheelchairs or crutches. They can participate successfully in some activities such as; basketball, volleyball, athletics among others.

How to help the learner

Design specialised fields for these learners. For example; smaller sizes of the playing area for easy mobility factor. In volleyball, for instance, the net should be about 6 ft in height. Serving by the normal learner is done from behind the back line and by the handicapped learner with the heels on the back line. Rules should be adjusted as necessary.

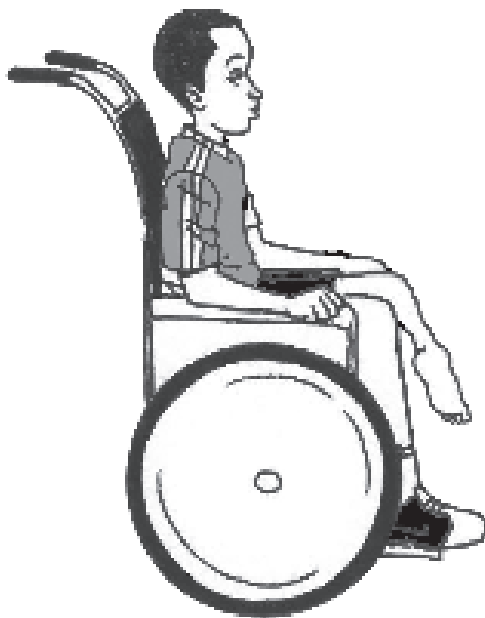

Lame learner in a wheelchair

e) Learners with epilepsy problem

Epilepsy is a dysfunction of the electrical impulses emitted by the brain. It is not an organic disease. It can happen at any period of life but generally shows up during early childhood. Epilepsy is a hidden problem. A learner with epilepsy looks, acts and is like other children.

How to help the learner

Talk to the learner, emphasise inclusion of the learner rather than the exclusion. Minimise climbing and elevated activities.

f) Learners lacking strength and endurance

These learners can be helped by lowering or enlarging the size of the goal. In basketball for example, the goal can be lowered . In football, the goal might be enlarged, for even the weak to score a goal.

You can also modify the tempo of the game. For example, the games might be performed using a brisk walk rather than running, or, stop the game regularly for substitution.

You can also reduce the distance that a ball must be thrown or served. Options are to reduce the dimensions of playing area or add more players to the game.

g) Learners lacking balance and agility

These learners once discovered can be helped by increasing the width of lines. If it is athletics, Beam size should be increased if it is practising balance.

Teach learners how to keep the feet spread at least to show wider width.

Increase the surface area of the body parts in contact with the floor or beam. For example walking flat footed is easier than walking on tiptoes.

Lower the centre of gravity. This offers more stability and greater balance to the learner. Emphasis should be placed on bending the knees and leaning slightly forward.

Learners with balance problem will inevitably fall. Practise in learning how to fall, should be offered so that learners gradually learn how to absorb the force of the fall.

Note:

The above categories of learners are ones with special needs. These learners are more challenged than others. This does not mean that physical activities are inappropriate for them. Be willing to adopt or modify skills or alternate your teaching style to accommodate the needs of each learner.

Physical Education and developing competencies

Competencies are the skills, knowledge and attributes gained through every work like educational, volunteer and life experiences. Learners in the Physical Education programme develop the following competencies such as:

- Deeper understanding in a broad range of knowledge.
- High-level thinking skills, such as problem solving, creativity and critical thinking.
- Effective social and cooperative skills.
- Competitive skills.
- A strong sense of cultural identity, belonging, contribution and well-being.

Physical education contributes to all of the generic competencies. Success in team sports depends upon effective communication and cooperation to ensure that the team is greater than the sum of its parts. Learners need to think critically about their own and other people's work and performances and they also need to be creative in developing solutions to challenges. The problem of how to improve health, fitness and skills and hence to perform better requires considerable strength in problem-solving.

Broad competence in Physical Education

By the end of this physical education programme, learners should be able to;

- Develop the physical, social, emotional and intellectual aspects.
- Develop personal competencies in a variety of individual and collective sports.
- Perform an appropriate range of movement skills in a variety of contexts.
- Develop an understanding of fair play and team spirit through participation and competition.
- Develop personal competences in a range of gymnastics movements.
- Develop personal competences in the athletic skills of running, jumping and throwing.
- Develop an appropriation of movement and the use of the body as an instrument of expression and creativity.
- Interact and cooperate sensitively with others, regardless of cultural or social background or special needs.

Demonstrate positive attitudes and values towards physical activity and its contribution to lifelong health-related fitness, thus preparing the learner for the active and purposeful use of leisure time.

- Develop personal competences in the game skills of sending, receiving and travelling using a variety of equipment and to apply these skills in game situations.
- Encourage fair play and a competitive spirit.

Teaching and learning Physical education

Appropriate instruction in physical education incorporates best practices derived from both research and experience in teaching learners. This physical education curriculum sets developmentally and instructionally appropriate practices in designing, implementing and evaluating physical education programmes. The following approaches are used:

a) Direct-teaching Approach

The direct-teaching approach involves the teacher giving instructions or showing learners what to do and observing their progress. It entails the teacher making all, or most of the decisions concerning the content of the lesson and the learner responding to instructions. It allows learners to practice skills within a game situation where the teacher decides on the nature of the practice and the time allocated to it or the number of repetitions.

b) Guided-discovery Approach

The guided-discovery strategy involves the teacher designing a series of physical exercises that will eventually lead to one or more appropriate competencies and ultimately the discovery of a particular concept or solution. It is one of the approaches that offer learners the opportunity to make decisions, solve problems or take initiative. The use of this approach promotes discussion among learners and enhances their learner's capacity to evaluate.

c) The role of the teacher in teaching Physical education

When teaching physical education, the teacher plays a big role of a facilitator by helping the learners to develop a positive self image, cooperation with others and a sense of fair play.

The teacher identifies the needs of the learners the nature of physical exercises to be done according to their level and abilities.

The teacher organises the learners in the teaching area, provides the appropriate materials and demonstrates the handling of the apparatus and the way the experiments should be carried out.

The teacher must ensure that the learners experience a variety of vigorous and challenging activities and he/she foster to stimulate and secure environment in which the learner can be creative and imaginative.

The teacher must have due regard for safety by ensuring that the learner adopts safe practises and take into consideration for the particular needs of each learner.

He/She has to evaluate and assess the progress of the learners.

d) Role of learners

Learners should be involved in a wide and increasing range of physical activities including gymnastics, athletics, sports and games. They should have the opportunity to refine the standards of their performance and to develop and evaluate their own movements, strategies and tactics. They should be introduced to a range of games and sports such as individual sports like Athletics and Gymnastics and Collective sports like football, netball, basketball, handball, goal ball and volleyball.

Assessment approach in Physical education

Assessment is an integral part of teaching and learning in physical education, as in other areas of the curriculum. The following forms can be used to assess in physical education teaching learning process:

- Teacher observation

This is the most useful and most consistently used form of assessment in physical education. It involves the informal monitoring of learner's progress as the actual learning takes place and most information is gathered in this way.

Teacher observation might focus on the responses which the learner make when doing a task for instance; the responses they make towards the teacher's questions and suggestions, the participation of the learner individually, in a group or as part of the class, the interaction of the learner with others when involved in group work the understanding displayed by the learners when engaged in activities.

Teacher observation as a form of assessment is particularly appropriate for physical education, as assessment is best undertaken as the learners are engaged in activities.

Some of the learning behaviour of a student can be observed to help plan for follow-up activities: for example, how a learner uses a piece of apparatus may guide the teacher in helping him/her to use it or other apparatus more effectively in subsequent lessons.

It is useful to record these observations.

- Teacher-designed tasks:

Throughout the physical education programme, teachers continuously design a variety of tasks for the learners to engage in. Some tasks will be designed to provide opportunities to practise skills, some will be designed to encourage creativity, some to gather knowledge of activities and others to promote questioning and group discussion before carrying out the task and as the task is being completed.

While engaged in the tasks, the learners are learning and simultaneously, their responses indicate their progress in physical education.

- Recording learner's progress

Teachers should assess and record learner's progress using indicators. These indicators are related to elements of Physical Education and teachers match their observations to the indicators as the learners undertake work.

Any report of learners progress might contain information gathered by the use of the assessment techniques outlined above, related to;

- The attitude of the learner to participation, which is indicated by factors such as;
 - acceptance of winning or losing.
 - understanding of fair play.
 - the appropriateness of dress code for the physical education lesson.
 - the effort displayed by the learner.
 - the application of safe practices.
- The learner’s achievements related to the elements of physical education which he/ she engages in, which are indicated by factors such as:
 - physical competence.
 - knowledge and understanding of activities.
 - creative and aesthetic development.
 - development of health-related fitness.

Sample evaluation sheet

Rope-jumping checklist

Learner’s Name	Jump in place	Jump, turn both ends	Jump, pendulum swing	Double jump	Backward jump	Stretch jump	One-leg jump	Forward jump	Scoring
									0= No performance 1= Partial performance 2=Consistent and complete performance

Available resources for Physical education

When teaching Physical education in small schools or schools with limited facilities where schools have specific problems related to a lack of indoor and outdoor space, consideration might be given to:

- The use of the classrooms, corridors and school grounds for orienteering exercises.
- The provision of markings on the playground for athletic activities and small-sided games.
- The use of local facilities, like community centres, parish halls, youth clubs and so on.
- Co-operation with other primary or secondary level schools in sharing facilities.
- Allocating more time to physical education in good weather.
- Visiting an outdoor education centre providing facilities for many worthwhile activities.

Suggested list of equipment for physical education

The ratio of equipment to each learner is an important consideration. Where possible, for game lessons each learner should have access to his/her material being used, for example; a ball per learner or per pair of learners. Similarly, for throwing and catching practices, each learner or pair of learners should have a ball or throwing objects like javelin, discus and shot put.

Some aspects of the athletics programme require little or no equipment, but to provide a comprehensive programme, certain basic equipment is necessary:

- plastic hoops, canes, skipping ropes, beanbags, wire skittles, foam hurdles plastic cones, multi markers or space markers, braids (fibres or ribbon), plastic racquets, plastic or alloy relay batons, plastic, ball-carrying nets, chalk, tape, stop-watch. Gymnastic mats are a basic requirement and an adequate supply of these and necessary to ensure maximum participation. A mat should be available for every two to four learners where possible.

Suggested equipment for outdoor (individual and collective activities)

The school may provide a variety of equipment for use by class groups. For example; wall-climbing courses, rope walls ad so on. Within the school, it may be possible to construct adventure trails using benches, mats, climbing-frames and so on. The teacher also has to initiate learners to fabricate their own traditional materials like karere (locally made balls)etc.

The teacher must be qualified in physical education subjects and should have considerable knowledge in other linked subjects like psychology and biology especially in Human anatomy where a strong point of observation and movement analysis is required.

The teacher must be capable of interpreting the correct and wrong movements done by learners and should know how to make corrections.

For learners with disabilities, the teacher has the responsibilities of identifying the degree of disability, providing appropriate materials and preparing exercises accordingly. At this level, follow up, appreciation and encouragement are the tools of success.

SAMPLE LESSON PLAN FOR S.2 PHYSICAL EDUCATION CLASS

A COMPETENCE - BASED LESSON PLAN

School name: Kigali Secondary School				Teacher's name: Kagabo John			
Term	Date	Subject	Class	Unit No.	Lesson No.	Duration	Class
I	24 Feb 2017	Physical Education and Sports	S.2	4	1/8	40 Min	40 Students
Type of special Educational needs to be catered for in this lesson and number of learners in each category				No case with special Educational needs			

Unit Title	Athletics	
Key Unit competence	To perform different types of running, jumping and throwing techniques and abilities	
Title of the Lessons	Running exercises (Sprint starts and sprint relays)	
Instructional (lesson) objective	By the end of the lesson: » learners should be able to perform different running races, techniques and abilities following instructions given by the teacher and using provided materials properly.	
Location	Playground (Running track)	
Learning materials for all learners	Running track, whistle starting blocks (if any), stopwatches, wooden clapper, First-Aid kit	
References	High performance splinting Smith, Mike Ramsbury: Crowood, 186126755X, 2005	
Timing for each step	Description of teaching and learning activity	
	Learners will perform sprint starts and sprint relays with techniques through different exercises provided individually and in groups. The corrections will be made progressively.	
	Teacher's activities	Learners activities
Generic Competences and cross cutting issues to be addressed		

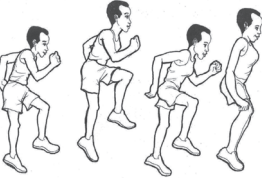
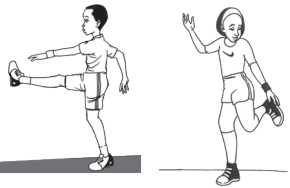
<p>Introduction: 5 minutes Initial discussion:</p>	<p>In working room or ground, discuss with students of previous lesson and introduce the new one by asking them some questions</p>	<p>Respond to the teacher's questions</p>	<p>Gender: Both boys and girls participate equally in all learning activities.</p>
<p>Warm up:</p>	<p>Asking learners to run around the playground without speed.</p> <p>Telling learners to change exercises:</p> <p>Telling learners that at every whistle they change direction.</p>	<p>Running one behind another around the ground without speed, when the whistle is done, jump and raise up their arms.</p> <p>Doing stretching.</p>  <p><i>Learners doing warm-up exercises</i></p>	<p>Cooperation: All learners perform warm-up exercises together</p> <p>Peace education and values: Learners performing exercises following teacher's instructions</p>
<p>Stretching:</p>	<p>Ask one learner to lead stretching exercises helped by the teacher and others follow</p>	<p>Following and perform stretching exercises</p>  <p><i>Learners stretching their muscles</i></p>	<p>Ceativity: One learner should demonstrate to others.</p>

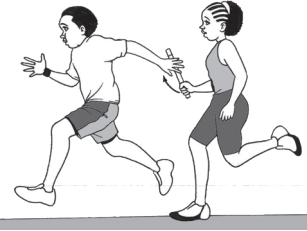
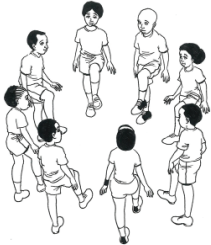
<p>Lesson body</p> <p>30 minutes</p>	<ul style="list-style-type: none"> - Explain and demonstrate the sprint start of 100 m, 200 m and 400 m - Explain and demonstrate relay baton exchange 	<ul style="list-style-type: none"> - Learners follow the demonstration and perform exercises of sprint start of 100 m, 200 m, 400 m.  <p style="text-align: center;"><i>The start</i></p> <ul style="list-style-type: none"> - Learners follow and perform exercises of running 4 x 100 m relay, 4 x 400 m relay. 	<p>Peace education and values:</p> <p>Learners follow teachers instructions during the exercise.</p> <p>Gender:</p> <p>Both boys and girls participate equally in all running activities.</p> <p>Cooperation:</p> <p>All learners perform relay exercises together</p>
<p>Conclusion:</p> <p>5 minutes</p> <p>Cool down:</p> <p>Final discussion:</p>	<p>Ask learners to perform cool down exercises.</p> <p>Asking learners questions reflecting the lesson, connecting skills to their daily life and its importance.</p>	<p>Learners perform the cool down activities.</p>  <p>Learners answer the teacher's questions.</p> <p>Learners return back in the classroom after removing used materials and washing themselves.</p>	<p>Peace education and values:</p> <p>Respect of views of others, communication, leadership</p> <p>Environment and sustainability:</p> <p>All learners should work together to remove used materials and washing themselves</p>
<p>Teacher self-evaluation</p>	<p>The objectives are well achieved and competence are well developed.</p>		

UNIT 1: MOTOR CONTROL

Content map for Unit 1

Item	Content
Key Unit Competence	Perform Exercise Routines based on its importance to health
List of lessons & Titles	Movements
Introduction	Movement is an act of moving the body or part of the body. All physical activities are associated with movement. Physical activities that promote movement include aerobics, anaerobic.
Classroom Organisation	Whole class orientation, individual practice, pair work and playing in a team in the playground.
Equipment required	Playground, ropes and mats
Activities	Aerobics like cycling, swimming, skipping rope are part of movement. Anaerobic like push ups, lunges, bicep carls, flexibility accuracy agility training speed.
Competences practised	Perform exercises in body development. Label the importance of physical activities in body fitness.
Language practice	Discussion in pairs, in groups. Explanation on the demon.
Vocabulary acquisition	aerobic , bicep carl, anaerobic, muscular brisk walking, flexibility
Numeracy	Counting the number of teaching materials used in a lesson.
Study Skills	<ul style="list-style-type: none"> - To create exercise based on body healthy living. - To explain the role of physical activities to body development creativity skills.
Learning outcomes	Perform aerobic exercises like cycling, swimming, rope skipping. Perform flexibility, bend, balancing on hand and arm stretch exercises.
Cross - cutting issues	Gender: Allow both boys and girls to take an active role in movement exercise. Environment: Emphasising the role of all learners in ensuring its conservation.
Assessment criteria	Setting exercises and evaluate how learners perform exercise routines based on their importance for health.

Key unit competence:

Learners will be able to perform exercise routines based on its importance to health.

Learning objectives:

Knowledge and understanding

- Explain the role of physical exercise in body development.
- Label the importance of physical activities in body fitness.
- Discuss the role of taking responsibilities in physical activities.

Skills to be developed

- To create exercise based on body healthy living.
- To explain the role of physical activities to body development.
- To evaluate the role of good leadership when practising physical sports activities.
- Creativity skills
- Leadership skills

Attitudes and values:

- Self-confidence.
- Self-control.
- Self-perception
- Appreciation of good leader in success of given activities.
- Appreciation of physical exercises in healthy living.

Lesson 1: Movement

Lesson objective

By the end of the lesson, learners should be able to perform different physical exercises so as to promote fitness.

Teaching methods:

- Demonstration.
- Discovery
- Command
- Instruction.
- Problem solving
- Explanation

Teaching materials:

- playground
- ropes
- mats
- whistle.
- sticks
- dumb-bells

Lesson development

Introduction

Guide the learners to perform warm-up exercises. Let them stretch and strengthen their muscles from the neck to the ankle or vice versa.

Brief learners about what they are going to learn in this unit. We are going to learn about exercises of basic physical training and muscular development. We are also going to learn about exercises of relaxation, exercises of improving body fitness.

Exercises of basic physical training

Cycling, swimming and skipping

Exercises of muscular development

Push ups, lunges

Exercises of improving body fitness

Swimming, sprinting and weight lifting

Exercises of relaxation

Jogging, stretching and walking

Lesson body





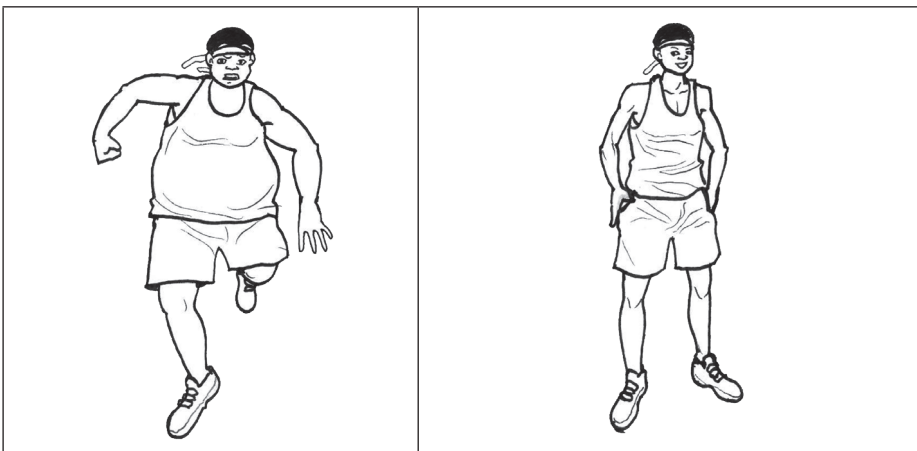



Teaching points:

- Guide students through warm-up activities. These help to heat and loosens the body and prepare the mind for action. Example; brisk walking, the jog around the playground.
- Explain to learners the role of physical exercises in body development. Example:
 - Helps to maintain physical fitness.
 - Promotes overall health and wellbeing of the body.
 - Boosts immune system. This helps to prevent heart diseases, cardiovascular diseases, diabetes and obesity.

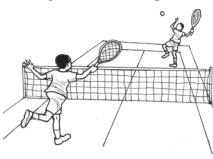

An obese person before exercising and slim after exercise

- Helps to prevent stress and obesity.
- Promotes and maintains positive self - esteem.
- Builds healthy bone density.
- Promotes muscle strength and joint mobility.
- Guide learners on how to perform different physical exercises. These are generally grouped into three types. See the table below:

Physical exercises		
Aerobic	Anaerobic	Flexibility
- cycling 	- push-ups 	accuracy training 
- swimming 	- lunges 	- agility training 
- skipping a rope 	- biceps curls (using dum-bells) 	- speed training 

Note:

- Aerobic exercises use large muscle groups. They cause the body to use more oxygen than it would while resting. They increase cardiovascular endurance.
- Anaerobic exercises are also called **resistance training**. They build strength, improve on bone development, work on body balance and coordination.
- Flexibility exercises help to lengthen and stretch the muscles. They improve on joint flexibility and keep muscles flexible.

Aerobic Exercises

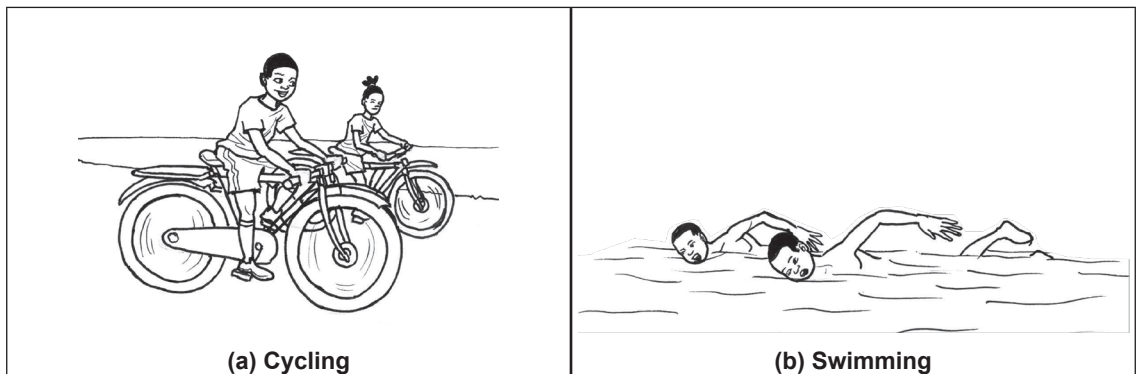

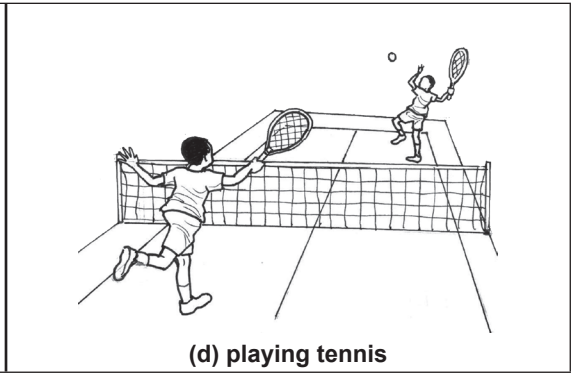
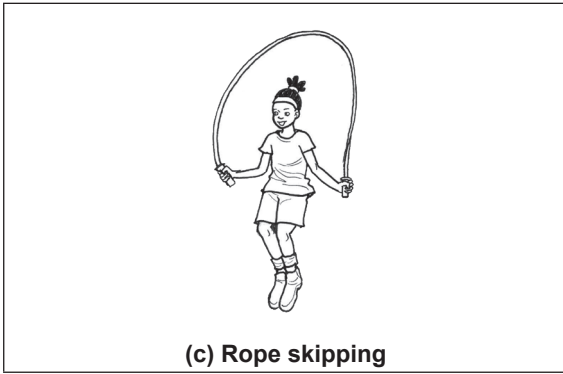

Anaerobic Exercises

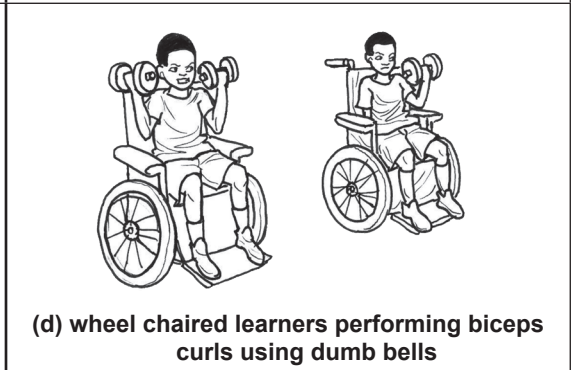
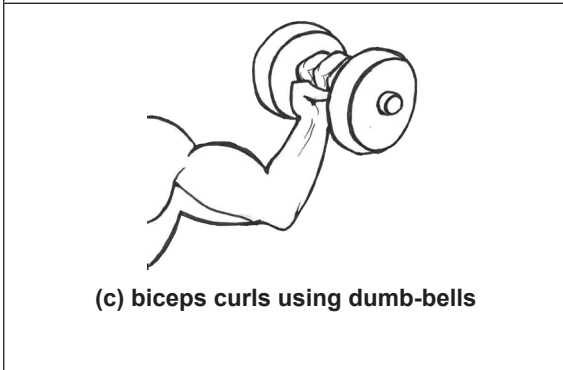
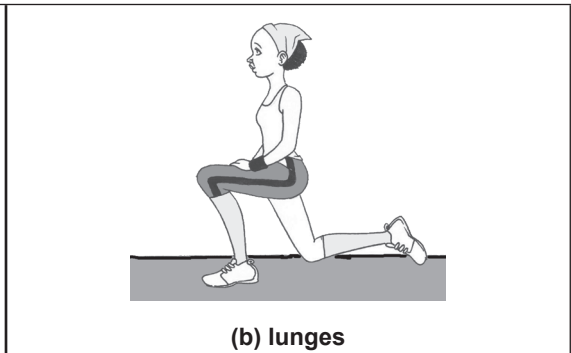
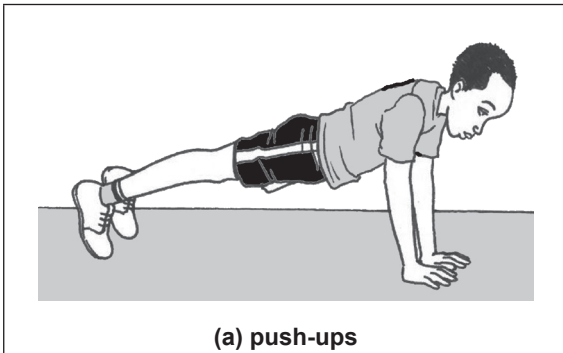

Flexibility Exercises

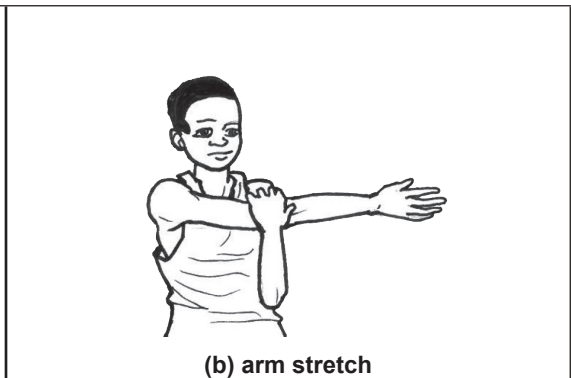
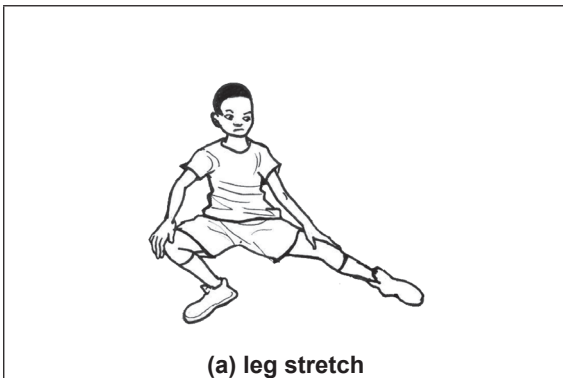

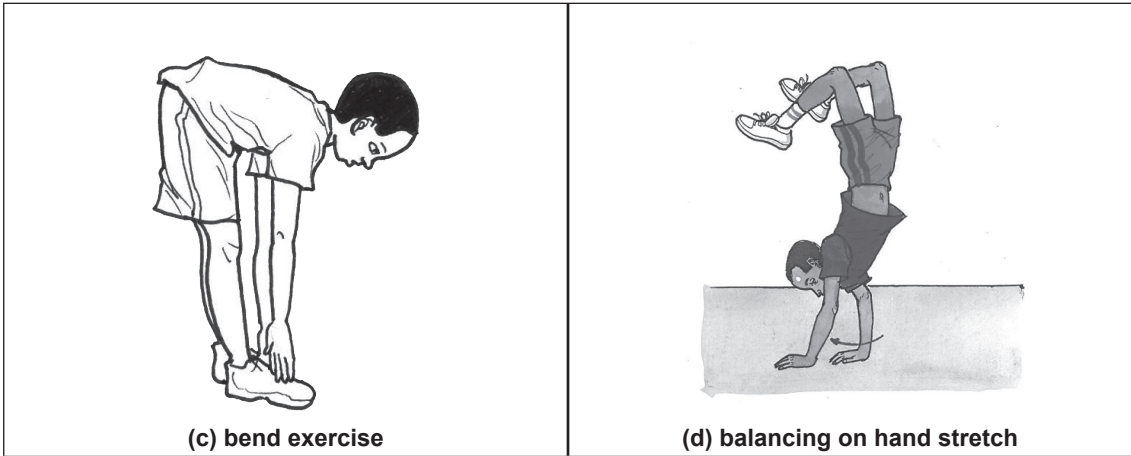

Cool down

Guide the learners to perform cool down exercises.

- Walking around the track.
- Stretching the muscles.

Final discussion

Guide the learners to discuss what they have learn about:

- Physical exercises in body development.
- Physical activities in body fitness.
- Importance of safe and responsible engagement in physical activities.
- How physical activity can be useful in their daily life.

End of unit assessment

Set exercises and evaluate how learners perform them on routine based programme.

Unit Summary 1

In this unit we have learnt about motor control emphasizing aerobic, anaerobic and flexibility exercises on movement and gymnastics.

In the next unit, we shall learn about body control and balance. We shall concentrate on pike position, straddle position and lying position of straddle exercises.

Unit Glossary 1

Flexibility : The quality of being flexible.

Aerobic : Physical exercise planned to improve on the performance of heart and lungs.

Brisk walk : Practically confident active and energetic while performing physical exercises.

UNIT 2: BODY CONTROL AND BALANCE

Content map for Unit 2

Item	Content
Key Unit Competencies	Express oneself and communicate through a variety of exercises.
List of lessons	1 - Body control and balance
Introduction	In this unit we shall learn expression and communication through movement, dancing and physical activities.
Classroom Organisation	Whole class orientation, individual practise, pair work and group work in the playground.
Equipment required	radios, drums, drumsticks, traditional video clips, resource persons and relevant books.
Activities	<ul style="list-style-type: none"> - Warm up activities. - Pike position activities. - Straddle position activities. - Standing piked straddle activities. - Lying piked straddle activities. - Traditional dancing activities.
Competences practised	<ul style="list-style-type: none"> - Extending the importance of communication during physical activities.. - Identifying different elements of movements during dancing activities. - Discussing the role of leadership in groups: <ul style="list-style-type: none"> - Self esteem - Competitive spirit - Self confidence - Observation spirit - Self perception - Courage
Language practice	<ul style="list-style-type: none"> - During brainstorming intervals. - In group discussions. - During practicing time.
Vocabulary acquisition	sensory, pike, supple, straddle.
Numeracy	<ul style="list-style-type: none"> - Counting seconds. - Counting steps taken.
Study skills	Ability to develop expression and communication which can be improved through a variety of exercises.
Learning outcomes	Ability to apply various systems of attacking and defensive systems during the game.
Cross - cutting issues	<ul style="list-style-type: none"> - Gender: Engaging both boys and girls in all activities. - Inclusive education: Adjusting activities by appropriately to suit learner's abilities. - Peace and values education: Having learners appreciating cooperation by working in teams.
Assessment criteria	Setting exercises and evaluation of how learners develop expression and communication when they are doing exercises.

Key unit competence:

Learners will be able to express oneself and communicate through a variety of exercises.

Learning objectives:

Knowledge and understanding

- Explain the importance of communication during physical activities.
- Identify different elements of movements during dancing activities.
- Discuss the role of leadership in groups.

Skills to be developed

- To demonstrate the elements of movement during dancing activities.
- To explain the role of dancing in body development.
- To develop communication.
- Leadership.

Attitudes and values:

- Self-esteem.
- Self-confidence.
- Self-perception
- Courage.
- Competitive spirit.
- Observation spirit

Lesson 1: Body Control and balance

Lesson objectives

Perform different physical exercises that promote body control and balance.

Teaching methods:

- Demonstration.
- Instruction.
- Command
- Explanation

Teaching materials:

- playground.
- radio.
- drum
- drumstick
- video clips showing different traditional and modern dances in Rwanda

Lesson Development

Introduction

Guide the learners to perform warm-up exercises. They should stretch and strengthen their muscles from the neck to the ankle.

Briefly describe to learners the importance of studying about body control and balance. balance is important to our normal everyday life activities. We need coordinated

balance while walking, bending, running and everything we do in our daily life. The major component that governs body balance includes;

- Sensory system. This gives information about body's position in relation to the environment.
- Brain's ability to process this information.
- Muscles and joints for coordination of movements required to maintain balance.
- Identify for students parts of sensory systems that helps in body balance.
 - feet
 - ankles
 - joints

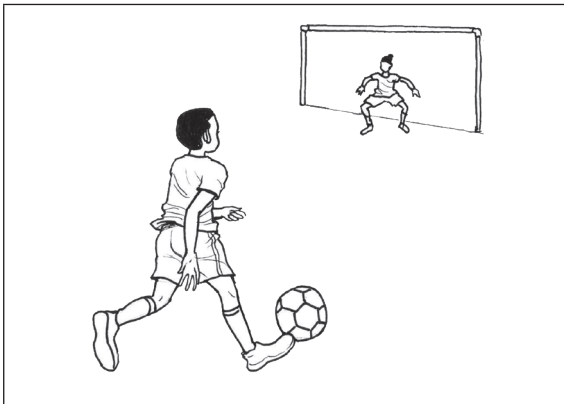

A learner rolling the ball to the opponents goal

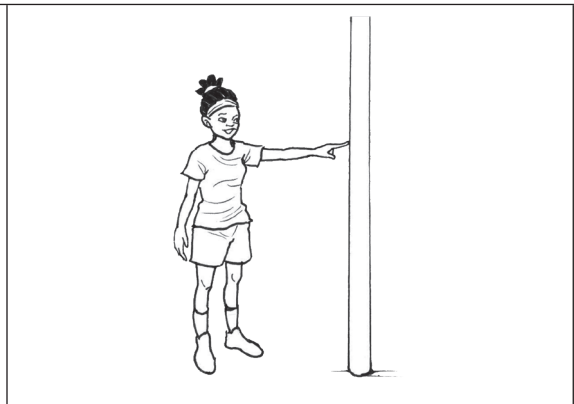

A learner showing systems of sense of touch feet, ankles and joint, eye, ears.

- Tell learners that, we rely on our feet and joint to tell us if the surface we are standing on is even or not. The eyes help to tell us if the environment is in motion or still. The ears tell us if we are upright or leaning or standing still or moving. If there is a disorder in the system above, you will lose balance.
- Explain to students ways in which body balance can be improved. This can be through performing suppleness exercises. These help the person to bend and move parts of the body to different positions easily.

Lesson body

(i) Pike Position exercises

Teaching points

- Instruct learners to sit down with legs together.
- Instruct them to bend forward and stretch their hands to touch the feet.
- Tell them to hold at the position as you count 1 - 10.

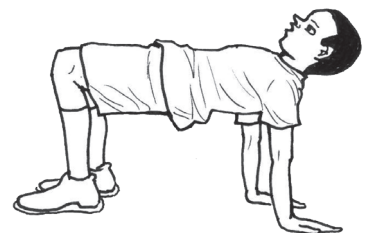

Pike exercise

(ii) Teaching points for Straddle position exercises

- Instruct learners to spread their legs while still in sitting position. Legs should be kept straight.
- Tell them to bend forward and aim at touching their feet.
- Tell them to hold at the position as you count 1 - 10.



Sitting Straddle position

(iii) Teaching points for standing piked straddle

- Instruct learners to stand with legs apart at shoulder width.
- Bend forward to touch the left foot.
- Move the hands on the floor to touch the right foot.
- Tell them to hold at that position and you count 1 up to 10.



Standing piked Straddle position

(iv) Teaching points for lying position of Straddle

- Instruct learners to lie down facing the floor.
- Tell them to lift themselves using hands off the ground. They should only lift the upper part of the body from the waist.
- The lower part of the body including the thighs and legs should remain on the ground.
- Tell them to hold at that position and you count 1 up to 10.

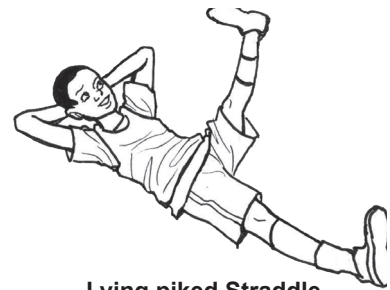

Lying piked Straddle

Exercises of different styles of dancing according to the given rhythm

- Tell learners that music and dance are integral parts of Physical Education. They are also part of Rwandan life and culture. They are part of different festivals in Rwanda. For example; birth, naming of children, marriage, birthdays, anniversaries and many other occasions.
- Tell learners that in order to perform very well in the dancing styles, one has to be physically fit.
- Ask learners to mention some of the different traditional dances. Let learners demonstrate to the class how the identified traditional dance is performed.
- Compare the learners response to the following traditional dances that require different styles of dancing.

(i) Intore dance of warriors

- The word **Intore** means the "Chosen - ones" It is performed by male dancers. These are selected basing on their physical and moral qualities.
- Teach this type of dance to learners using music - dance steps and shouts based on strength of students. You can accompany the dancers (learners) by a drum orchestra made of about seven to nine learners. The drumming provide a harmonious and yet powerful rhythms. It portrays mens courage.



Intore dance

(ii) Umushagiro or Umushayayo dance of women

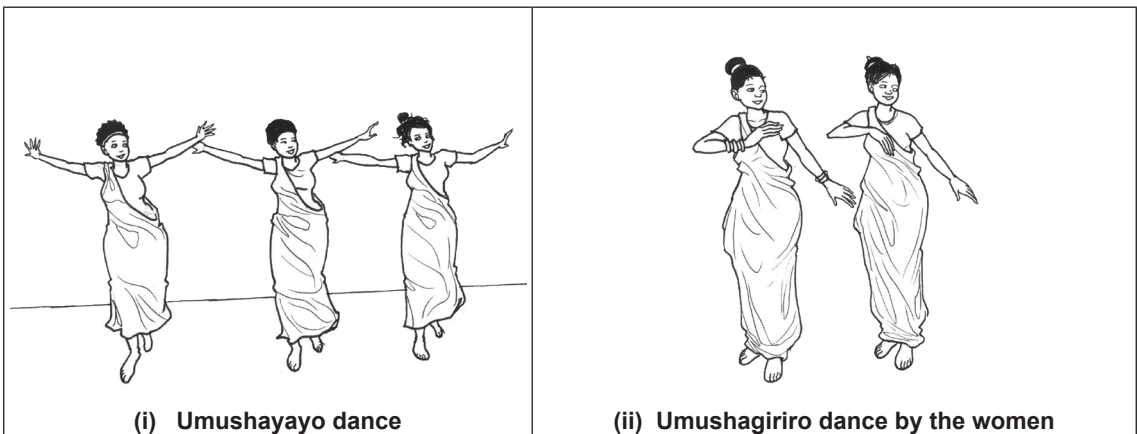

- Choose one student to lead others in performing Umushagiriro dance. This is a dance of women. It is more gentle and graceful. The dancing style is according to movement of hands and feet showing the kindness, goodness and purity of Rwandan women. This dance emulates the movement pattern of the Inyambo cattle.

Note:

The traditional dances and a variety of modern songs are a form of physical exercises. They are used to demonstrate agility especially when performed in groups. The dance is different. It is essentially about movement and rhythm.

Cool down

Providing cool down exercises.

Final discussion

Lead a discussion about relating to the lesson, connecting the skills to the daily life and their importance.

End of unit assessment

Set exercises and evaluate how students develop expression and communication when they are doing exercises.

Unit Summary 2

In this unit we have learnt expression and communication through movement, dancing and physical activities.

In the next Unit, we shall be learning various gymnastics movements and identifying ground exercises to apparatus exercises.

Unit Glossary 2:

Pike position : Perform a gymnastic activity bending at the waist with straight legs

Supple : bending and moving easily.

Straddle : To sit or stand with one leg on either side of a horizontal or parallel bars

Sensory : To feel something.

UNIT 3: GYMNASTICS

Content map of Unit 3

Item	Content
Key Unit Competence	Perform gymnastic movements
List of lessons	1 - Gymnastic exercises done on the ground and using apparatus.
Introduction	In this unit we are going to learn various gymnastic movements and identify ground exercises to apparatus exercises.
Classroom Organisation	Whole class orientation, individual practise, pair work and group work in the playground/gymnasium.
Equipment required	phinth trampoline, bars trees, ribbons, horizontal and parallel bars, whistles, bails, clubs, mats, gymnasium, playground, resource persons, relevant books, pommel horse, beam.
Activities	<ul style="list-style-type: none"> - Warm up and cool down activities. - Three legged standing activities. - Rolling forward activities. - Rolling backward activities. - Hand stand activities. - Parallel and horizontal bar activities. - Tumbling and trampoline activities. - False scissor activities. - Front support swing activities. - Rhythmic gymnastic activities. - Artistic gymnastic activities.
Competences Practised	<ul style="list-style-type: none"> - Demonstrating the best way of making gymnastic movements. - Identifying ground exercises to apparatus exercises. - Self esteem - Self control - Learning from mistakes
Language practice	<ul style="list-style-type: none"> - During brainstorming intervals. - During both individual and ground practice. - During class discussion in groups.
Vocabulary acquisition	Tumbling, dynamic, stride.
Numeracy	<ul style="list-style-type: none"> - Counting steps. - Counting seconds as you hold a position. - Estimating degrees and angle from the beam. - Measuring distance.
Study skills	<ul style="list-style-type: none"> - Analysing various gymnastic actions done on the ground. - Describing the movement of any gymnastic action. - Carrying out different ground and apparatus exercises. - balancing.

Learning outcomes	Ability to increase and perform various gymnastic movements.
Cross - cutting issues	<ul style="list-style-type: none"> - Gender: Engaging both boys and girls in all activities. - Inclusive education: Adjusting activities by appropriately to suit learner's abilities. - Peace and value education: Encouraging cooperation by having learners work together in pairs and groups.
Assessment criteria	Setting exercises and evaluating how learners perform various gymnastic activities.

Key unit competence:

Learners will be able to increase and perform gymnastics movement.

Learning objective:

Knowledge and understanding

- Describe the movement of any gymnastic action.
- Identify ground exercises to apparatus exercises.

Skills to be developed

- To analyse various gymnastics actions done on the ground.
- To carry out different ground and apparatus exercises.
- Balance.

Attitudes and values:

- Self-confidence.
- Self-control.
- Hope
- Learning from mistakes.
- Dexterity.

Number of lessons : 1

Lesson 1: Gymnastics exercises done on the ground and using apparatuses

Lesson objective

Perform gymnastic exercises on the ground and using apparatus.

Teaching methods:

- Demonstration.
- Instruction.
- Guided discovery
- Command
- Explanation

Teaching materials:

- playground.
- tree
- circle
- ribbon
- parallel and horizontal bars
- plinth
- pommel horse
- beam
- whistle.
- balls
- clubs
- mats
- gymnasium
- trampoline
- uneven bars
- soil

Lesson Development

Introduction:

- Step 1: - Guide the learners to brainstorm on what they know about gymnastics.
 - Discuss with them what they have not mentioned.
- Step 2: - Instruct one learner to lead others in the warm-up of muscles. This can include jogging, squats, knee jumps.
 - Instruct learners to stretch the backs by forming a bridge - like shape. Learners lie on the floor, bend knees, feet placed on the floor.
 - Lift oneself with hands palm. The fingers should be pointed to the feet.
 - Command learners to continue stretching their backs by assuming the position of elbows pointing to the ceiling as they stretch their muscles.

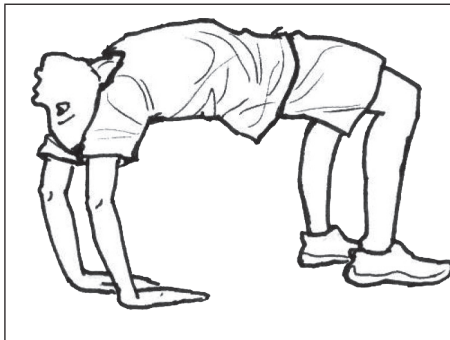

Bridge stretch



Back stretch as elbows point up.

Safety consideration

Note:

Do not force the back to bend past the capacity. You might develop back injuries.

- Tell learners that flexibility is so important to gymnastics. So, the more they become flexible the more they perform better.

Lesson body

Examples of gymnastic exercises without apparatus

(i) Three - legged stand

- Tell learners that we can balance our bodies on different parts. The body can balance on two legs, hands, one leg or legs and hand.
- Demonstrate the three legged stand and ask learners to try it out. Tell them to hold at the position and you count from 1 up to 10.

(ii) Rolling forward

- Ask one learner to lead others in forward roll.
- Start with legs spread in the Straddle position.
- Bend forward at the hips.
- Tuck the head.
- Place the hands on the mat or ground.
- Roll forward, while pushing yourself with hands.

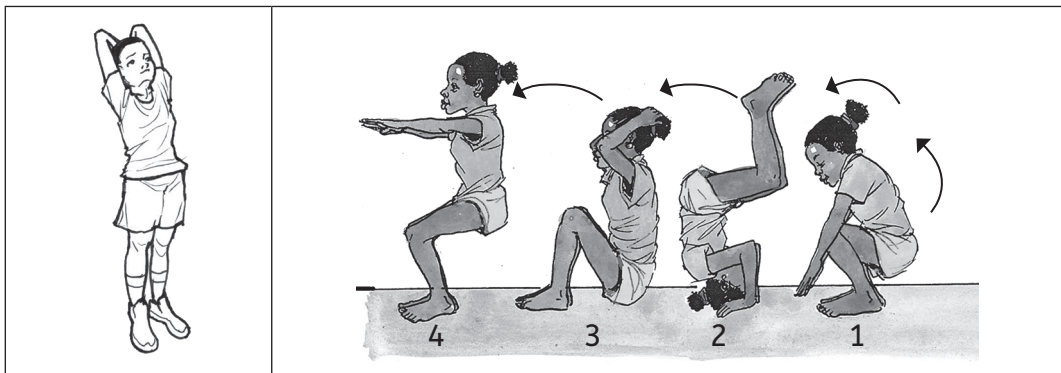

(i) Back stretch as elbows point up.

(ii) Forward roll

(iii) Rolling backwards

- Choose another student to lead others in the back roll.
- Start with clasping the fingers behind the neck. The elbow should be held out.
- Sit down.
- Bring the knees to the chest for a tuck to secure momentum.
- Roll completely over backwards. Put much of the weight on the forearms.

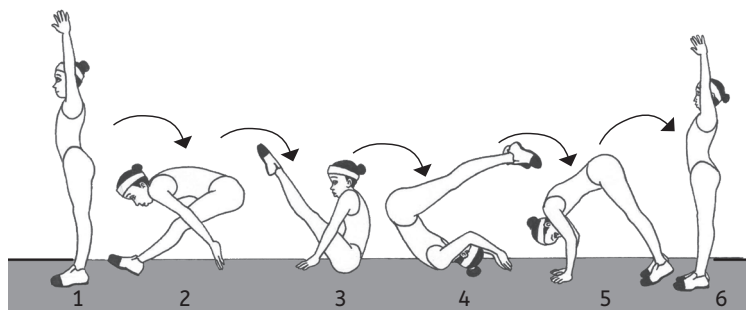

Backward roll

Safety Consideration:

Note: Take care of the neck as you perform forward and backward rolls.

(iv) Hand stand exercise

- Instruct learners to perform the handstand in pairs. One supports the other during the performance.
- Start within a stride position with the forward knee bent.
- The learner transfers his or her weight to other the hands.
- The body goes into the hand stand position with a one - two kick up.
- The other learner who is not performing holds the performer in an inverted position.

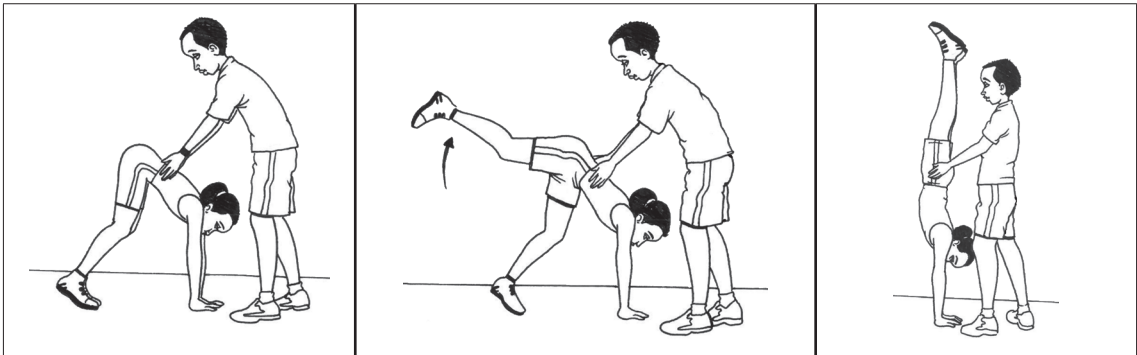

Hand stand with a spotter.

Examples of Gymnastic exercises of using apparatus

(i) Parallel and horizontal bar exercises

- Instruct learners to get balance beam.
- Place each leg on the side.
- Keep the toes pointed towards the ground and legs flexed.
- Use hands for support while holding the balance beam.
- Lift yourself up and down.
- Then straighten on your legs while supporting yourself on the balance beam and hold there for some time.

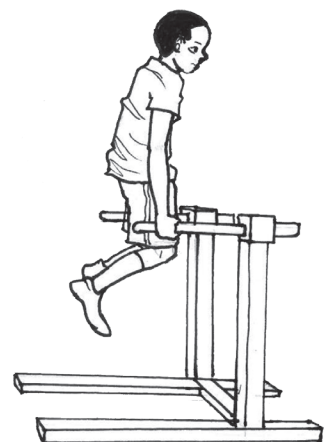

Parallel bar exercise.

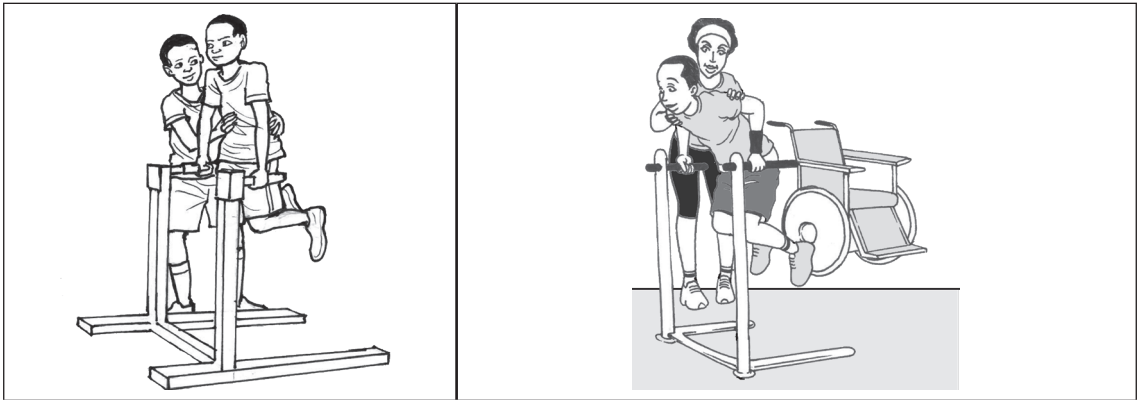

Parallel bar exercise with support.

A wheelchaired learner lifting up and down in wheelchair.

- On the balancing beam, perform a v - hold.
- Put the hands on the beam behind you.
- Raise your legs and toes at about 45° degrees angle from the beam. Hold this pose for about three (3) seconds.

(ii) Tumbling and trampoline exercises

- Make learners familiarise themselves with the trampoline before exercising on it.
- Let learners bounce on the trampoline for sometime as they get used to the general force.



Learner's bouncing on the trampoline.

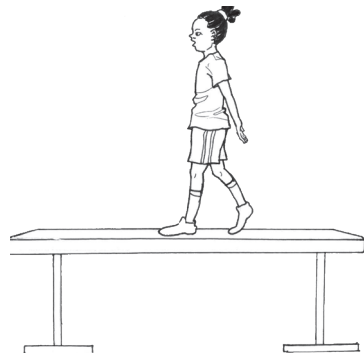

V - hold on balancing beam

- Direct learners how to perform a tuck jump on the trampoline.
- Instruct learners to jump high as they can. This should be done at the centre of the trampoline.
- Keep the body straight and push through the arms up over head to maximise the strength of the entire body.
- At the highest peak of the jump, touch the knees to the chest and hold.
- As gravity brings you down, kick the legs back out before landing onto the trampoline.
- Train learners to perfect in majorly two skills here, the good stride swing and goo circle. Teach them to counter turn their hips and move their hands well.
- Encourage learners to perform their circles using clockwise direction.



Tuck jump

Note: A pommel horse stands 115 cm tall, 160 cm long and 35 cm wide.

Basic Skill in Pommel exercise

(i) False Scissor

Have the learner work a stride swing at the peak of the stride plane their front leg on the horse while keeping their back high and extended so they end in a straddle side support.

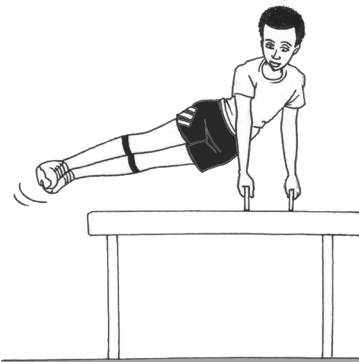

False scissor pommel exercise.

ii) Front Support Swings

- This should remain straddled throughout.
- As the top leg peaks the learners should think about driving the bottom leg upwards. Tell learners not to wait until the top leg has begun to come down.

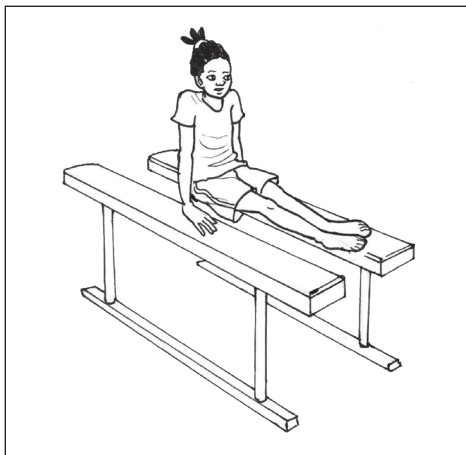

Front support swing.



Learners rolling the balls under their legs.

(iii) Rhythmic gymnastic exercises

The activities in rhythmic gymnastics are routines done to music by a performer. It is done using a particular type of manipulative equipment.

- Guide learners to perform the routine with partners or in team competitions. This will promote cooperation among the learners. You need balls, jump ropes, hoops, clubs and ribbons.
- The Rhythmic Gymnastics help to develop qualities such as balance, coordination, flow of body movement and rhythm. Fitness qualities of agility, flexibility and proper posture are also developed.

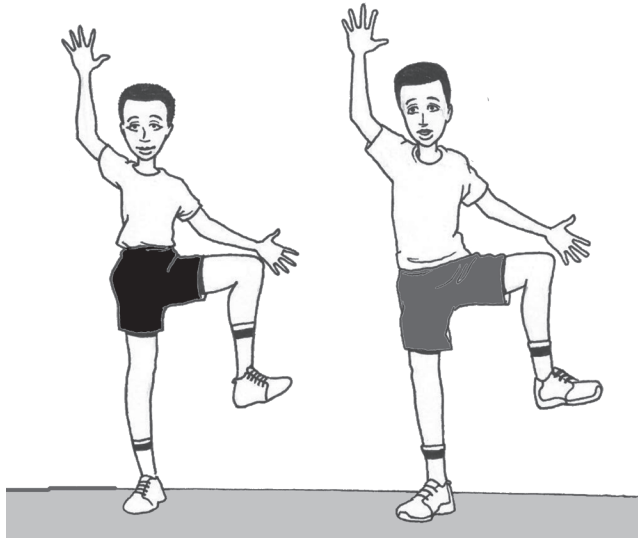

RhythmicGymnastic skills

(iv) Rhythmic Ball Skills Gymnastics

- Give learners balls. Instruct them to play with the ball while rolling them under the legs, and around the back, around the body, down the legs and arms, lift the legs and toss the ball of the toes into the air and catch.
- Instruct learners to bounce the balls. Combine basketball dribbling drills with graceful body movements. Excuse locomotor dance type movements while bouncing the balls.
- Tell students to toss and catch the ball while employing different body positions. Add locomotor movements to tosses and catches.
- Tell learners to throw and bounce the ball in a variety of ways.



Learners bouncing the balls.

(ii) Rhythmic rope routines

- Instruct learners to try single and double jumps forward and backwards.
- Tell them to circle the rope on each side of the body holding both ends of the rope.
- Command them to figure - eight swings, holding both ends of the rope, holding the centre of the rope and swinging the ends.
- Swing the rope in pendulum fashion and jump it.
- Instruct students to run or skip over a turning rope. Try forward and backwards.

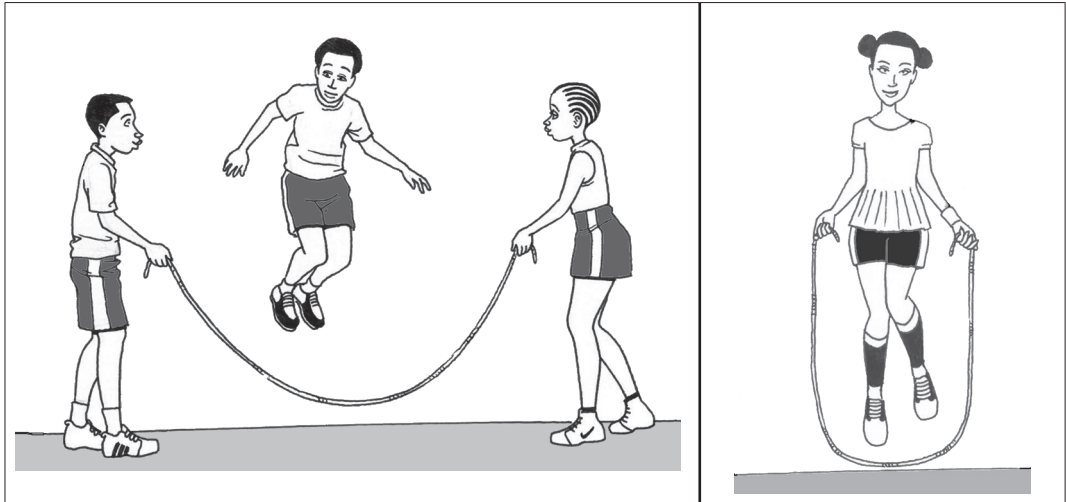

Learners skipping over a turning rope.

(iii) Rhythmic Gymnastic Ribbon movements

These movements combine elements of dance and gymnastics. Carefully examine the students flexibility, pivots, leaps, balances and artistry.

Note:

- The ribbon can be different colours and design. The length of the ribbon depends on what level the ribbon should not be shorter than six metres in length. It must be between four (4) to six (6) inches in width.

Instructional exercise

- Tell learners to begin a pivot by semi - squatting with both feet on the floor.
- Instruct them to raise the toes.
- Bring the free leg up while simultaneously bending it.
- The body should be turning on the supporting leg while performing the above moves.
- With the ribbon in hand, extend the arms towards the body.
- The learner should keep hi/her shoulders aligned and back straight while facing ahead.

Artistic Gymnastic Activities

Test learners' ability to perform the following artistic gymnastics.

(i) Flow gymnastics

- Hand stand

- Hand stand bridge
- Straddle handstand

(ii) Prolls

- Front
- Back roll
- back roll to handstand

(iii) Handsprings and cartwheel

- Front handspring
- back handspring

(iv) Pommel Horse

- Double leg circle

Cool down

Providing cool down exercises.

Final discussion

Lead a discussion about relating to the lesson, connecting the skills to the daily life and their importance.

End of unit assessment

Setting gymnastic exercises and observe how learners perform them.

Unit Summary 3

In this unit we have learnt various movements in gymnastic done on the ground and using apparatus. In the next Unit, we shall be learning various techniques used in running, jumping and throwing.

Unit Glossary 3:

Dynamic : A process of constant change or progress.

Stride : To walk with long, decisive steps in a specific direction.

Tumbling : To make handstands and somersaults in the air

Handstands : Using the hands to stand.

UNIT 4: ATHLETICS

Content map of Unit 4

Item	Content
Key Unit Competence	Develop different types of running, jumping, throwing techniques and abilities
List of lessons	<ol style="list-style-type: none"> 1. Running exercises 2. Hurdles exercises 3. Jumping exercises (Long Jump) 4. High Jump exercises 5. Triple Jump exercises 6. Throwing exercises (The shot put) 7. The Discus exercises 8. The Javelin exercises
Introduction	In this unit we are going to learn the various types of running, jumping and throwing with respect of regulations.
Classroom Organisation	Whole class orientation, individual practise, group work, pair work, free play in the playground.
Equipment required	<ul style="list-style-type: none"> - running track - whistle - stopwatch(es) - First aid kit - relevant books - bibs - takeoff board - tape measure - high jump stands - weighted objects <ul style="list-style-type: none"> - starting blocks - wooden clapper - resource persons - sand pit - rake/hoe - crossbar - mats - javelin - medicine balls
Activities	<ul style="list-style-type: none"> - Warm-up activities - Jumping to the sand pit - High jump activities - Triple jump trials - Shot put guide technique - Shot put competition - Javelin throwing <ul style="list-style-type: none"> - Running activities - Long jump activities - Competitive high jump - Putting the shot - Shot put glide technique - Discus throwing
Competences practised	- Communication, application, creativity, accept defeat, lifelong learning.
Language practice	<ul style="list-style-type: none"> - During warm up sessions. - During brainstorming intervals. - During free play. - During discussion segments.
Vocabulary acquisition	<ul style="list-style-type: none"> - Sprints - Flight - Hurdle - Flip <ul style="list-style-type: none"> - Sail - Relay - Fosbury flop <ul style="list-style-type: none"> - Baton - Landing - Takeoff

Numeracy	<ul style="list-style-type: none"> - Counting the number of steps. - Measuring distance. - Timing sprints.
Study skills	<ul style="list-style-type: none"> <li style="width: 50%;">- running <li style="width: 50%;">- balance <li style="width: 50%;">- jumping <li style="width: 50%;">- leadership <li style="width: 50%;">- throwing <li style="width: 50%;">- endurance <li style="width: 50%;">- coordination <li style="width: 50%;">- suppleness <li style="width: 50%;">- speed <li style="width: 50%;">- force
Learning outcomes	- Ability to perform different techniques of running, jumping and throwing.
Cross - cutting issues	<p>Gender: Engaging both boys and girls in practice.</p> <p>Inclusive education: Adjusting activities to suit all learner's abilities.</p> <p>Peace and values education: Having learners work together in groups and promoting fair play during games by following rules.</p>
Assessment criteria	Setting exercises and evaluation of how learners perform different techniques of running, jumping and throwing..

Key unit competence:

Learners will be able to develop different types of running, jumping and throwing techniques and abilities.

Learning objectives:

Knowledge and understanding

Stating various types of running, jumping and throwing with respect of regulations.

Skills to be developed

- running
- suppleness
- jumping
- speed
- throwing
- force
- endurance
- balance
- coordination
- leadership

Attitudes and values:

- courage
- determination
- patience
- competitive spirit
- dexterity
- perseverance

Lesson 1: Running exercises

Lesson objectives

By the end of the lesson learners should be able to develop different running races, techniques and abilities.

Teaching methods:

- explanation
- practical
- direct instruction
- demonstration
- guided discovery

Teaching materials:

- running track
- whistle
- stopwatch(es)
- starting blocks (if any)
- wooden clapper
- first - aid kit

Lesson development

Introduction

Guide the learners to perform warm - up activities. One of them should lead. They should heat up the muscles through simple exercises like jogging, chasing one another in pairs to mention but a few. Let them stretch systematically in the order:

Either: From neck to ankle or.
 From ankle to neck or.
 From middle to neck the middle to ankle.

Next they perform strengthening exercises like; push ups, polyometrics, triceps dips, pull ups, sit ups, planks and burpees.

Step 1 : Let the learners brainstorm on the definition of the terms:

- Spirit starts and sprint relays.
- Track and field.

Athletics: Athletics involves the sports of track and field, long distance running (including road running and cross - country) and race walking.

Track events: These are races performed on the track such as sprints, relays and hurdles.

Step 2 : Let the learners explore the sprint and sprint relays they know: Track events: These are short races performed on the track at relatively short period of time. They include 100 m, 200 m and 400 m.

Sprint relays: These are mainly two namely; 4 × 100 m and 4 × 400 m.

Step 3 : Organise the learners to carry out the following sprints and relay in small groups of either 6 or 8 members: 100 m, 200 m, 400 m, 4 x 100 m and 4 x 400 m relays.

The recovery period for an individual should be at least 5 minutes between the events.

Step 4 : Let the learners brainstorm on what they understand about middle distance and long distance.

Middle distances: 800 m and 1,500 m.

Long distances: 3,000 m - ladies.

5,000 m - men

10,000 m - both

Step 5 : Let the learners calculate the number of laps for each race by dividing by 400 m (complete lap on a standard track):

: 800 m - 2 laps

1,500 m - 3.75 laps

3,000 m - 7.5 laps

5,000 m - 12.5 laps

10,000 m - 25 laps

Assessment

Organise the learners according to their ability in five different groups. Let each group perform one of the following races: 800 m, 1,500 m, 3,000 m, 5,000 m and 10,000 m. Using a stopwatch, time each learner and record. Encourage them to break this record when you meet again.

Cool down:

- Guide the learners to perform cool down exercises. These may include walking around the track, simple jogging and stretching.

Final discussion

- Guide the learners:
- to explain the reasons of using techniques in athletics.
 - to state different types of running, jumping and throwing with respect of regulations

Additional notes

Athletic Techniques

- There are three different athletics techniques. These include; running, jumping and throwing.
- The running races are referred to as track events because they are performed on the running track.
- Other running events that are not performed on the track are the cross country (of any agreed upon distance) and the Marathon race (42 km).

Track Events

- The track is made up of six to eight lanes.

- The standard length for the innermost lane is 400 m internationally.
- Each lane is 1.22 m - 1.25 m wide.
- The number of laps (journey around the track) is calculated by dividing each given race by 400 m.
- Study the calculations below:

$$100 \text{ m} \quad \frac{100}{400} = \frac{1}{4} \quad \text{lap (run on the straights)}$$

$$200 \text{ m} \quad \frac{200}{400} = \frac{1}{2} \quad \text{lap (run on the curve and straights)}$$

$$400 \text{ m} \quad \frac{400}{400} = 1 \quad \text{lap (one lap around the track)}$$

$$800 \text{ m} \quad \frac{800}{400} = 2 \quad \text{laps}$$

$$1,500 \text{ m} \quad \frac{1500}{400} = 3\frac{3}{4} \quad \text{laps}$$

$$3,000 \text{ m} \quad \frac{3000}{400} = 7\frac{1}{2} \quad \text{laps}$$

$$5,000 \text{ m} \quad \frac{5000}{400} = 12\frac{1}{2} \quad \text{laps}$$

$$10,000 \text{ m} \quad \frac{10000}{400} = 25 \quad \text{laps}$$

- For 400 m the lanes have to be staggered in order for athletes to cover the same distance.
- For 800 m, the athletes can either start on the staggers for the first lap and the all use the first lane during the second lap.
- Or start on the curved line and run towards the first lane after about 200 m.

Field Events

- Field events include the jumps and throws.
- The jumps mainly performed at this level are three namely; Long jump, High jump and Triple jump.
- The Pole vault is performed at advanced level. A cage of wire mesh must be set around the throwing area as a safety precaution.

Sprint Techniques

There are three variations:

- Sprint stride (Full flight striking action).
- Sprint drive (Starting action).
- Sprint lift (Kick at speed)

Sprint technique work should have three areas of focus:

Posture: Focus attention on the position of the head, the trunk and the hips (in a hips - tall position).

Arms: Emphasize relaxing the hands and shoulders and concentrating on the direction of application of the force.

Legs: Emphasise the extension of the driving leg, the heel recovery and foot strike in relation to the centre of gravity.

The Start:

- The sprinter must have a starting position that will make his pattern of acceleration successful.
- To achieve success, the sprinter must overcome inertia by applying maximum force against the blocks/ground in the shortest time possible.

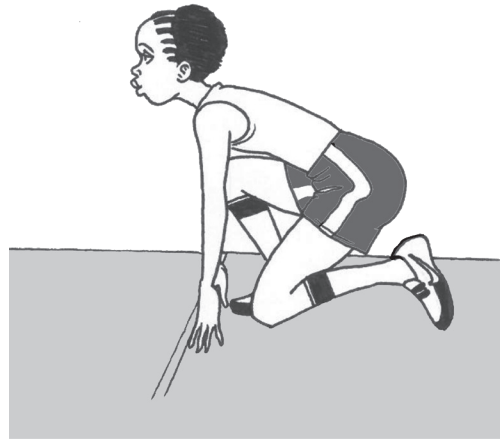

The Start

Block Placement:

- A simple method to determine block placement is your athletes' use the length of their feet as a guideline.
- The front block is placed one and one - half to two feet - lengths ahead of the back block.
- This puts the athletes in a set position close to the medium start points.

Set position

- The block settings should result into the athletes having a 90 - degree angle at the front knee.
- Then a 110 - 120 degree angle in the back of the knee.
- This gives a set position with the hips just slightly higher than the shoulders.
- They should feel pressure against the back block in the set position.
- When backing into the blocks so that pressure will automatically occur when they rise into the set position.
- The hands are placed just slightly wider than shoulder width apart, with the fingers and thumbs in a "high bridge" position.
- The shoulders are above and slightly ahead of the hands. The arms are straight although not locked.

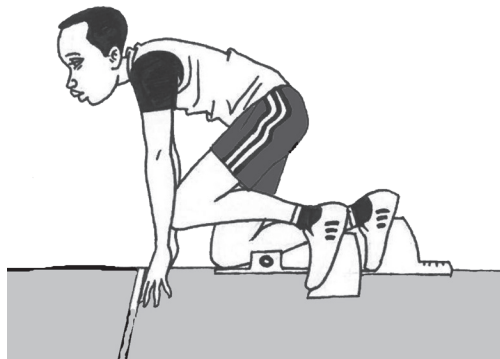

Block placement

Setting position

- The movement begins with the reaction to the sound of the gun/clapper/whistle.
- Such a reaction is a voluntary response that is under the athlete's control therefore it can be improved.
- For improvement, the athletes must learn the "appropriate coordinated joint action."
- This establishes the correct movement pattern, which is perfected through repetition during practices.
- Most of the block clearance/starting time should be spent applying force against the blocks/ground.
- The rest of the time is used in reacting to the gun/clapper/whistle and taking the hands off the ground.
- For good start, a sprinter must:
 - Concentrate on moving the hands and arms as quickly as possible in reaction to the gun.
 - Push back against the blocks/ground.
 - Drive out: the direction of the applied force should be out and up not up and out. That means the athlete should move the hips quickly from the starting position to a running position.
 - Run out of the blocks/shoot off the ground, do not jump out.
- Emphasise a final point about reaction and starting.
- The athlete who is first out the blocks (or off the ground) is not necessarily the first to cross the finish line.
- The winner is the one applying the greatest force in the shortest time.
- This application may not show until 20 m or 30 m into the race.
- In most cases, the athlete who clears the block quickly but applies less force against the blocks is (surpassed, overtaken, overrun) by the slower - starting runner who applies greater force.

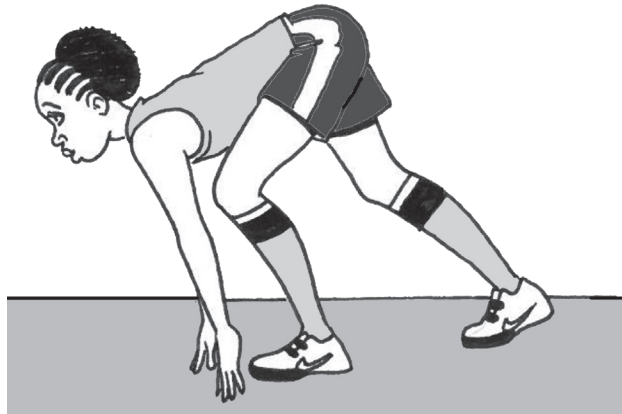

Set position

Sprint Relays

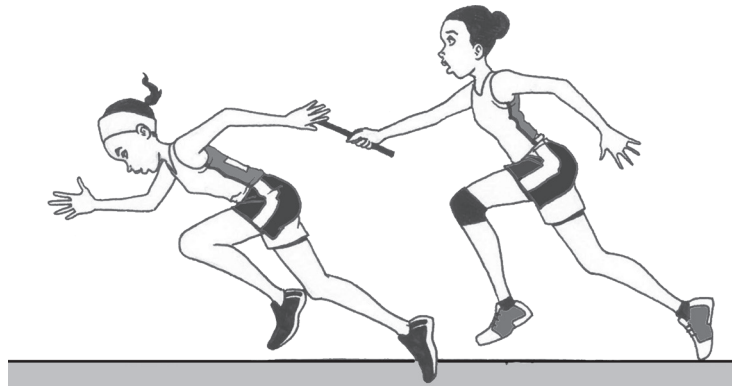

Sprint relays

The Exchange Techniques and their advantages (4 x 100 m Relay)

Down pass

- During this pass, the outgoing runner extends the receiving hand, palm up, the thumb towards the body.
- The incoming runner holds the baton by one end and places the free end in the hand of the outgoing runner.
- The three advantages of this pass are:
 - The free distance between the runners at the exchange.
 - The baton needs no adjustment in the hand after the pass.
 - The greater baton speed.
- The main disadvantage is the possibility of a moving target, presented by the outgoing runner.

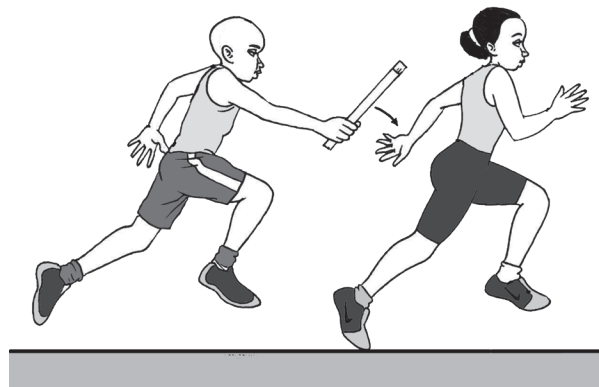

Down Pass

Upward Pass

- During this pass, the outgoing runner holds the receiving hand in an upside down "V" position near hip level.
- The incoming runner positions the baton so that the outgoing runner can grasp it near the incoming runner's hand.
- The major advantage of this pass is that it is simple for beginners to learn. Thus, runners initially have more confidence in this pass.
- The main disadvantage is that the baton needs adjustment in the hands after each pass. This creates a great risk of dropping the baton.
- Another disadvantage is that some incoming runners tend to overrun their outgoing

runners.

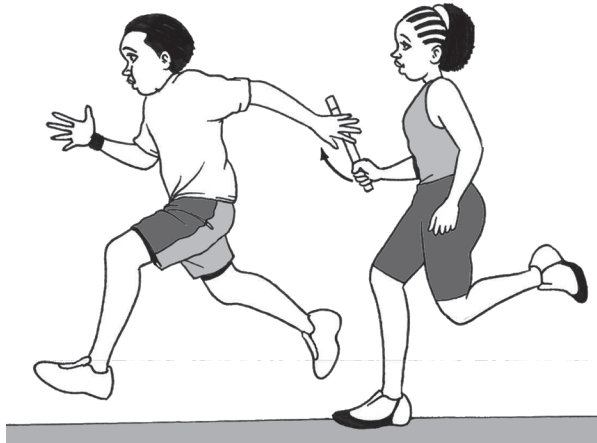

Upward Pass

Snatch Pass

- The snatch pass is similar to the downward pass at the point of exchange.
- The incoming runner holds the baton forward, using the outgoing runner's elbow as a target.
- The outgoing runner reaches back and grabs the baton.
- If the pass is missed on the first try, the outgoing runner continues arm-swing motion and grabs the baton on the second swing.
- This pass has the same advantage as the down pass.
- However, it has the potential for a much faster pass because it eliminates the possibility of the receiver, "finishing" and moving the target. This lessens the likelihood of the receiver decelerating

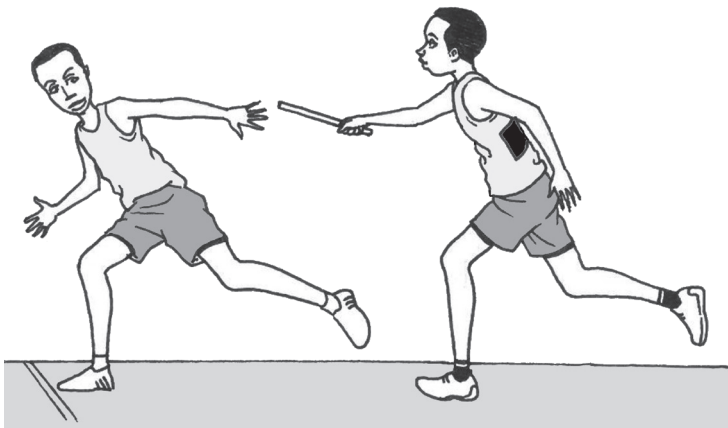

Snatch pass

Visual Exchange Techniques for the 4 by 400 m Relay

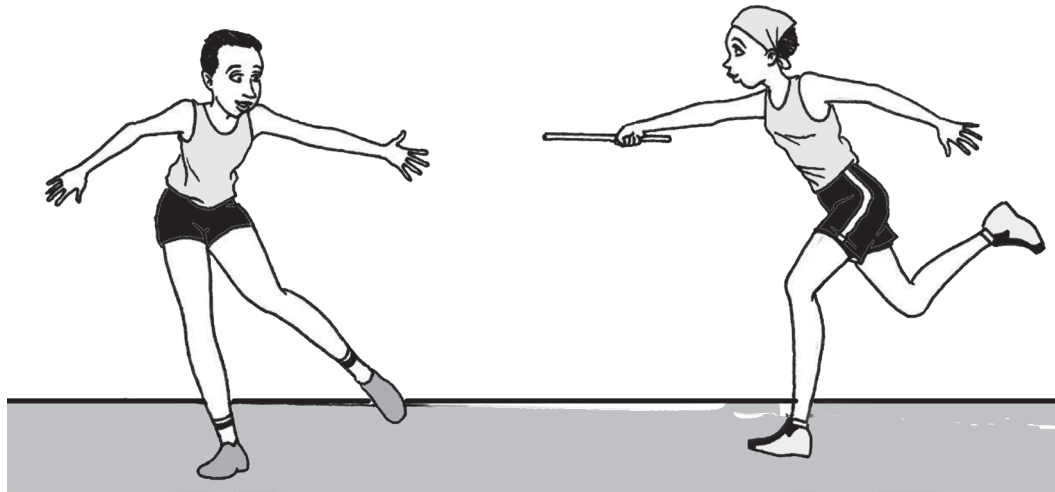

Visual baton exchange

- The success of exchange depends on the outgoing runner's ability to sense the incoming runner's fatigue levels.
- However, the incoming runner must still aggressively attack the exchange zone to avoid slowing down.
- A right to left exchange for all the three exchanges is recommended. This position allows the outgoing runner to face the in field and to see where the traffic is.
- The outgoing runner should switch the baton from the left to right hand as soon as possible after establishing a forward run.
- This allows the receiver to move the inside of the track during or after exchange, because he or she is looking to the inside while receiving the baton in the left hand.
- The outgoing runner must gauge the speed he or she needs to have to complete the exchange near the middle of the exchange zone, not allowing the baton to slow down.
- It is better for the receiver to gradually accelerate while moving towards the middle zone accelerating at the point of exchange rather than slowing down.
- The receiver waits for the baton with a hip and foot position similar to that in the 4 x 100 m, but with only a slight forward lean.
- Once the incoming runner reaches a point that the outgoing runner considers a signal to leave (a go mark/check mark) the outgoing runner turns the head and eyes to the front for three strides, then looks and reaches back with the receiving hand at the third stride to adjust his or her speed to match that of the incoming runner. The exchange should maintain the baton speed.

Baton Speed

The goal of all relays is to move the baton around the track as fast as possible. The following are some of the elements of relays that you must consider well in advance of competition:

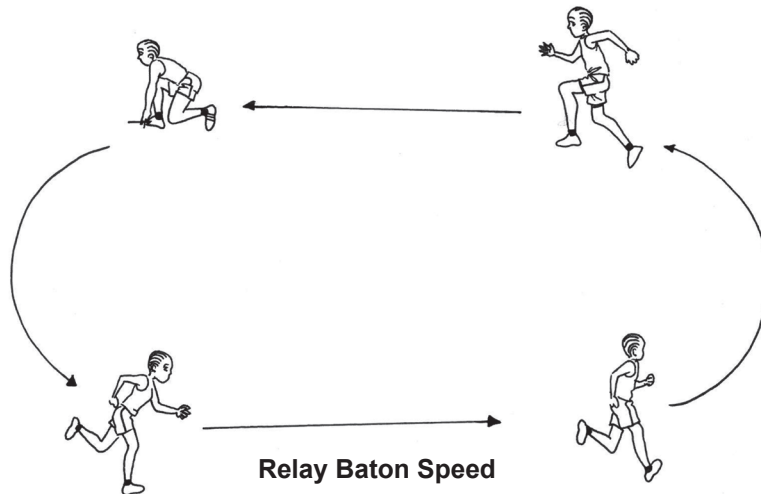

- Relay order.
- Use of the acceleration zone.
- Starting position of the outgoing runner.
- Establishing the go mark.
- Indicating to go mark.
- Take off and acceleration.
- Establishing the exchange point within the zone.
- Signalling the exchange.

Relay order

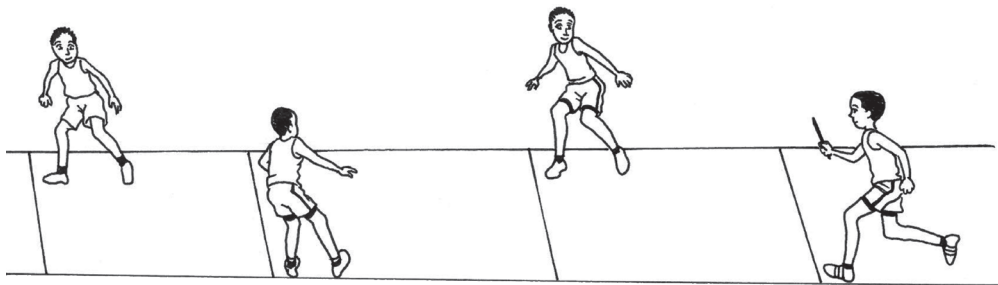

Left to right relay order

Many factors are considered in arranging a relay team's running order:

- Who is the best (fastest, most reliable) starter?
- Who are the best baton handlers?
- Who are the best curve - runners?
- What is each athlete's overall speed?
- What is each athlete's ability to sustain speed?
- How competitive is each athlete?
- What is the familiarity and experience level of teammates?

Starting position of the outgoing runner

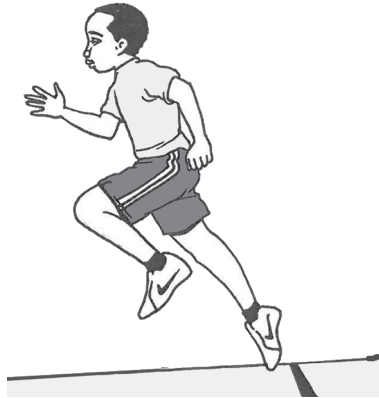

Starting position for outgoing relay runner

The outgoing runner has a few options from which to choose for the start:

- The runner may stand facing forward, leaning in a balanced position, with the back foot on the same side as the receiving arm. Then looks over the shoulder of the receiving arm which is forward with the hips and feet in the direction of the run, for the incoming runner.
- Another option for the runner is to assume a three - point stance. It is done by going down with the receiving hand to support a more centre of gravity. The non - receiving arm is back and the runner looks over the inside shoulder. This is a good starting position but often offers a poor visibility.
- A third option is the four - point stance, but this is not used often. The athlete must decide which stance best suites the race and his or her abilities.

Establishing the go mark

- The mark tells the outgoing runner when to start accelerating.
- When the incoming runner hits this point, the outgoing runner takes off.
- The relative speeds of both runners in the exchange zone determines the marks placement.

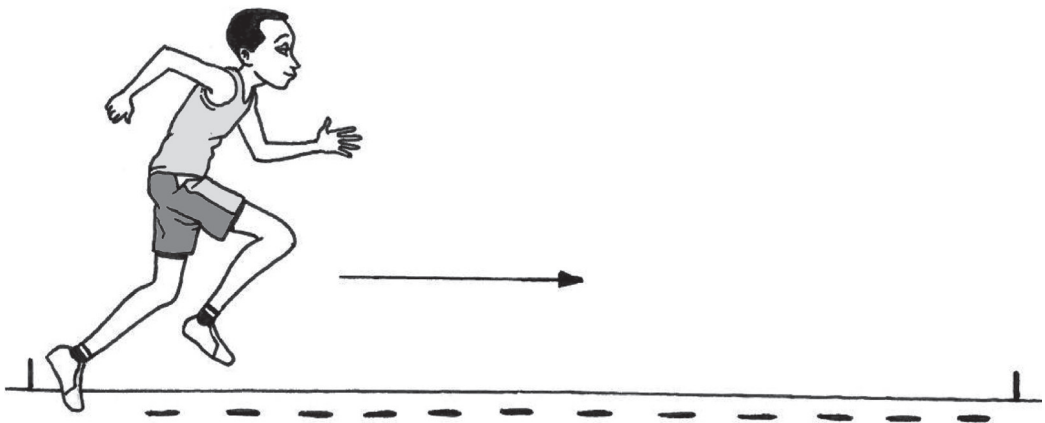

Establishing a go-mark

Indicating the go mark

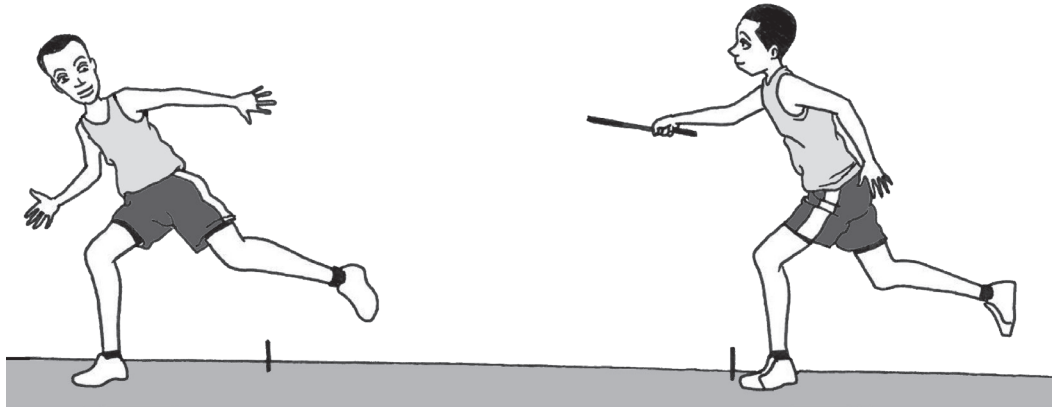

Indicating a go-mark

- Place the mark on the side of the lane upon which the incoming runner has taken.
- Make a distinguishing mark different from the other track markings.
- Examples include an x or x_s with tape or coloured chalk..
- **Note:** Always clear your marking materials with the track referee or management, because some materials can damage an all-weather surface.

A critical point mark is also useful. Place a mark near the end of the exchange zone. This warns the outgoing runner that the exchange should have taken place by that point. If the outgoing runner reaches the critical point mark without a baton, he or she should not stop. He or she should ease back to allow a bit more time for the incoming runners.

Physiological Stress

We have to understand how the body reacts to this type of stress.

- If the body is overworked, the results is a poor workout, poor race, or possibly injury or illness.
- "Too much too soon". is a true phrase. Learners should begin a training programme comfortably and not rush for competitive fitness.
- Gradually, add to the training distance and intensity.
- Overload the body gradually, then let it recover, and it leaps to a higher performance level.

Running action

- Each learner's running action has its own peculiarities.
- Still there are biomechanics laws that apply to everyone, therefore you must consider these to ensure that the learner is moving efficiently.
- Runners who don't use proper running mechanics waste energy and run slower.
- Use running techniques drills regularly in the training programme.

Strength development

- The stronger runner is able to train and race better than a weaker runner.
- A strength programme must be included in the overall programme.

- Distance runners should emphasise strength endurance in their strength routines.
- In general, select activities that provide overall body strength and balance.

The components of distance running ability

- A distance runner is dedicated to making continuous efforts.
- There is no defeat except from within, no barrier save his or her own weakness of purpose.
- Distance training has five basic components namely: Endurances, Strength, Flexibility, Speed and Running mechanics.

Endurance

Endurance is of two major types: aerobic and anaerobic. In aerobic endurance the cardiovascular system can meet the oxygen demands of the exercise, whereas in anaerobic endurance cannot meet those demands.

Strength

Two areas of strength need improvement:

- Muscle strength (capable of maximum efforts).
- Strength endurance capable of continuous efforts against resistance.

Flexibility

Efficient running requires proper mechanics. The runner can improve those mechanics by doing technique drills. However, running mechanics can be effective only if the working muscles of the body are in balance. For example, tight hamstrings may lead to improper running posture and restrict the legs' range of motion. Therefore a good stretching routine is necessary.

Stretching is an integral part of the warm-up, which includes light to moderate activity to prepare for more stressful activity. The long term purpose of stretching is to improve upon elasticity, the range of motion of the limbs and the body's balance.

Speed

Much as speed is very much needed during sprinting, it is also critical at top level runners (elite level) even in the longest races.

Lesson 2:Hurdles exercises

Lesson objective

By the end of the lesson learners should be able to perform hurdling drills techniques and abilities.

Teaching methods:

- Explanation
- Practical
- Direct instruction
- Demonstration
- Guided discovery

Teaching Materials:

- Whistle
- Stopwatch(es)
- First - Aid Kit
- Wooden clapper
- Hurdles
- Running track

Lesson Development

Introduction

Guide the learners to perform warm - up activities. Let one of them lead and others follow. Remind them to stretch systematically. Finally, let them strengthen their muscles.

Lesson body

Step 1 : Give the learners chance to brainstorm on what they know about hurdles and hurdling.

- Hurdles.

Hurdles: These are athletics equipment which are put on the track lanes at given recommended intervals. They act as obstacles for athlete(s) to go over whenever he/she comes across it until the finishing line.

Hurdling: This is the process of going over hurdles.

It has three phases: Take off, Hurdle clearance and Reacceleration. N.B. We don't jump over hurdles instead we hurdle over them (Hurdling)



Hurdle Stretch

Step 2 : Let the learners observe the hurdles and the heights. Men's hurdles 110 m, - 1.067 m, 400 m - 0.914 m and Women's hurdles 100 m - 0.840 m, 400 m - 0.782 m.

- Let them tell the two types of hurdles race. These are: 110 m hurdles and 400 m hurdles.

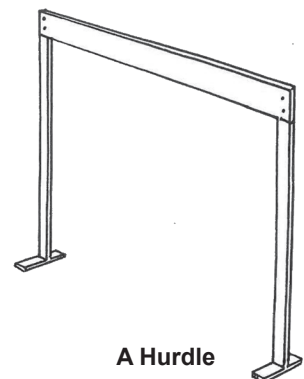

A Hurdle

Step 3 : Let the learners perform the hurdle drill.

High Knee March Drill

Begin by placing five or six hurdles at five to six foot length apart. The athlete in a hips - tall position, high on toes with erect posture, and approaches the hurdle walking. The aim is to get the hips as far from the ground as possible. The lead - leg action is performed over the side of the hurdle. The emphasis is on exaggerated knee lift and tall posture. As your athletes master this routine, they can also perform it in a running mode.

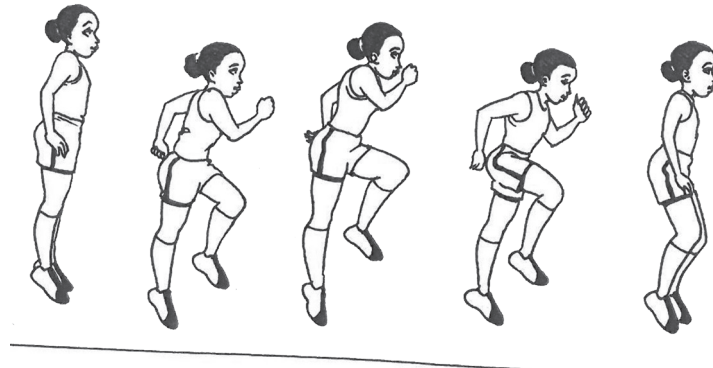

High knee march drill

Fast - leg drill

- Starting from a hips - tall posture, the athlete jogs and using only one leg at a time performs the simulated action of the full - sprint stride at high speed.
- The athlete actively pulls the heel tightly to the buttocks as the knee drives upwards.
- The thigh accelerates upwards, then immediately back towards the track (thus the term first - leg).
- After the action is performed once with just the one leg, the athlete jogs for two or three steps.
- Then repeats the same action with the same leg or opposite leg.
- In all, the drill is performed for 30 m to 40 m.
- The speed of the athlete increases as he or she proceeds down the track.

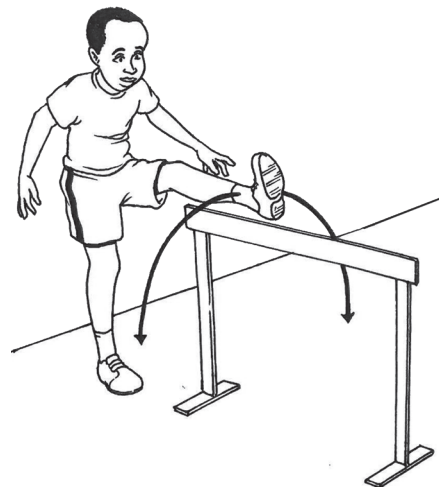

First - leg drill

Fence Trail - Leg Drill

- This exercise develops specific dynamic mobility and teaches correct trail - leg technique.
- This is a beginner's exercise, but it is good for more advance athletes.

- The athlete places the hurdle about 2 feet (60 cm) from the fence and parallel to it.
- The athlete faces the hurdle and the fence.
- Standing near the side of the hurdle, the athlete inclines the body towards and put one or both hands on the fence.

Partner Trail - Leg

- This exercise is performed like the previous drill, except that the hurdle is on the track and a partner replaces the fence.
- The partner actively pulls the athlete by hand as he or she performs the trail - leg movement.
- This shows the athlete how it feels to move quickly over the hurdle and begin coordinating a fast uninterrupted movement of the trail - leg with good speed over the hurdle.

Fast - Leg in 3 - step Rhythm

- The variation of the fast -leg routine uses the lead leg or trail leg only.
- The start of the routine is the same.
- When the first - leg action is performed, the athlete imagines that he or she is doing it over hurdles in a race.
- Each first - leg action is followed by a quick 3 - step rhythm of low height and short ground - contact time.
- The athlete should:
 - Perform this drill as an acceleration over 40 m to 80 m.
 - Keep the arm action vigorous.
 - Be sure to accelerate the thigh of the first - leg downward as well as upward.

Fast - Leg Lead over Hurdles

- The fast - leg action is performed with the lead leg over the side of 4 - 6 hurdles spaced 7 m to 9 m apart for the 3 - step (stride) rhythm.
- It can also be done 9 m to 13 m apart for a 5 - step rhythm.
- The hurdle height can vary from 1 foot to 3 feet.
- When performing the drill, the athlete should maintain the hips - tall body posture.
- He or she should follow the principles given for the fast - leg routines.

Activity : Hurdling

- Guide the learners to practise hurdling. Supervise them as you correct and encourage them. Let them follow the hurdling rhythm 1 - 2 - 3 - up.

Cool down

Guide the learner to perform cool down exercises. These may include jogging around the track and stretching the muscles.

Final Discussion:

Guide learners to discuss about the phases of the hurdling techniques:

Guide learners to explain the reasons of using techniques in athletics.

- take off; hurdle clearance and re-acceleration.

Guide the learners to tell the importance of hurdle techniques in their daily life.

Additional Notes

Common High - Hurdle faults and corrective techniques

Faults	Cause	Corrections
Excessive body lean, creating a jack-knife position over hurdle.	Poor sprint mechanics, such as excessive forward lean between hurdles.	Emphasise good sprint posture going into the hurdle with long force application of power foot going in to hurdle.
Taking off too far from the first hurdle.	The sprint strides are too short during the initial acceleration from the blocks or starting line. The blocks may be set too close together, resulting in a short first stride. The arm action in accelerating to the first hurdle may be too passive.	-The athlete needs greater contractive strength to drive from blocks (starting line) with enough stride length to make the 13 m distance in 8 strides. - Move the blocks to medium spacing and check the body angles in the start position. - Have the athlete lengthen the arm reach and increase the range of the arm movement.
Shoulders or hips not square to hurdle.	Poor arm action in sprinting; reaching across with the lead arm; driving the lead knee across the body.	Fence trail - leg drill.
Jumping action over the hurdle.	Taking off too close to the hurdle; forcing and upward instead of a forward trajectory.	Mark the takeoff point, increase speed by running over lower hurdles.
Locking the lead leg.	Leading with the foot rather than the knee.	Lead leg drills emphasising knee drive into the hurdle.
Premature turning of the take off foot.	Desire to start the trail - leg early.	Full extension of the take off leg off the ground before pulling the toe upward.

<p>To high over the first hurdle.</p>	<p>Too close to the hurdle.</p> <p>(a) Too close to the hurdle.</p> <p>(b) Takeoff foot planted on the heel.</p> <p>(c) Non active last step.</p> <p>(d) Lead leg not folded tightly until the thigh is parallel or above.</p>	<p>For (a), the athlete should stay in the sprint acceleration posture longer.</p> <p>For (b) and (c), the athlete should practise the hips - tall posture and make the first step active and on the toes of the takeoff foot.</p> <p>For (d), the athlete should practice the proper lead - leg mechanics and body posture going into the hurdle.</p>
<p>Taking off too far from the first hurdle</p>	<p>(a) The sprint strides are too short during the initial acceleration from the blocks/starting line.</p> <p>(b) The blocks may be set too close together, resulting in a short first stride.</p> <p>(c) The arm action in acceleration to the first hurdle may be too passive.</p>	<p>For (a), the athlete needs strong greater contractive strength to drive from the block/starting line. Sufficient stride length to make the 13 m distance in 8 steps is needed.</p> <p>For (b), move the blocks to the medium spacing and check the body angles in the start position.</p> <p>For (c), have the athlete lengthen the arm reach and increase the range of arm movement.</p>

<p>Off - balance coming off the hurdle.</p>	<p>The lead - leg and opposite arm are driven inward, not parallel to the direction of travel.</p> <p>- The trail leg opens up too soon.</p>	<p>- Work on the lead - leg mechanics to enable the athlete to keep actions in the direction of the run.</p> <p>- Work on the athlete trail - leg mechanics to keep the leg folded until the thigh reaches a position where the knee points in the direction of travel before the leg opens up towards the ground.</p>
<p>Hitting the hurdles late in the race.</p>	<p>Loss of rhythm.</p> <p>- Too close to hurdles.</p> <p>-Loss of concentration.</p>	<p>The trail leg is opening too soon, causing the get away stride to be too strong, which results in the take off foot being placed too close to the next hurdle.</p>

Lesson 3: Jumping Exercises (long jump)

Lesson Objective

Learners should be able to jump using the "Sail Technique" correctly in long jump event.

Teaching Methods

- Explanation
- Demonstration
- Practical
- Direct Instruction
- Guided Discovery

Teaching Materials

- Sandpit
- Takeoff board
- Tape measure
- Rake/hoe
- Whistle

Lesson Development

Introduction

Guide the learners to perform warm up activities. One of them should be the leader. Let them heat up the muscles through simple exercises like jogging, chasing and dancing. Let them stretch systematically in the order as put in lesson 1, and step 3.

Stretching exercises should be followed by strengthening exercises. For example, push ups, pull ups, sit ups and polymeric jumps.

Lesson body

- Step 1 : Let the learners brainstorm on what they know about long jump.
- Area where it is carried out.
 - The technique used.
 - How measuring is done.
 - How a winner is determines
- Step 2 : Guide the learners to discover the various techniques of long jump.
- Sail technique
 - Hang technique
 - Hitch kick technique.
- Tell the learners that you are going to concentrate on the sail technique.
- Step 3 : Guide the learners to discover that in all jumps, each technique involves three phases:
- Approach
 - Takeoff
 - Flight and landing
- Demonstrate the technique in relation to long jump

Activity 1: Jumping to the sandpit

- Using the longer side of the sandpit, let the athletes jump and land in the sand at least four at a time.
- This will help them to get used to the takeoff, flight and landing without fear.

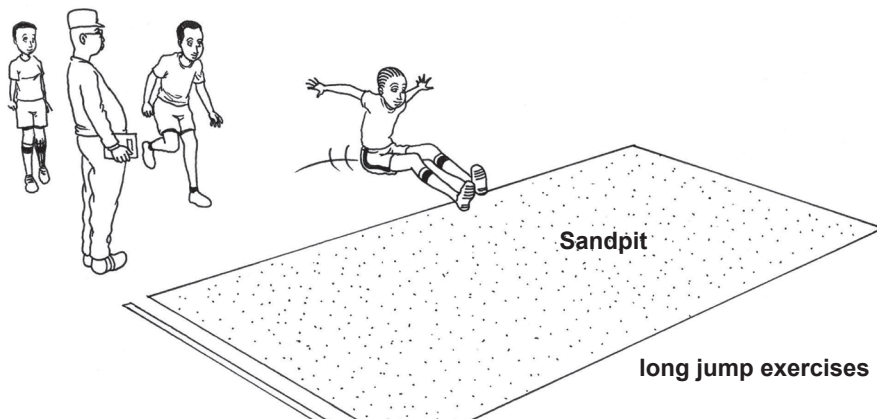

Activity 2: Long jump activities

- Now let the learners carry out long jump following the normal procedure: Approach, takeoff, flight and landing.
- Introduce the 13 or 15 or 17 or 19 steps approach. These steps are calculated by running top speed from the takeoff board to your assumed starting point.
- Put a mark at each individuals starting point.
- This helps the athletes to avoid making a "no jump" when he/she steps beyond the takeoff board.

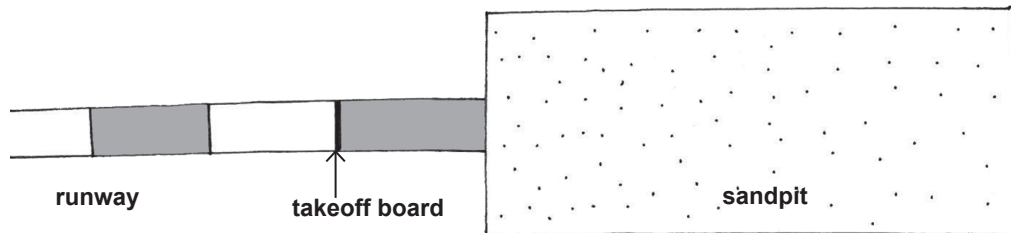

Running mat for the long jump

Assessment:

- Set exercises and evaluate the learners on how to perform different techniques of running and horizontal jumping.

Cool down exercises

Guide the learners to perform cool down exercises. These may include walking around the track, simple jogging and stretching.

Final discussion

- Guide the learners to discuss about the phases of long jump:
 - approach
 - takeoff
 - flight and landing
- How is long jump useful for us?
- How does long jump help people in their daily life?

Additional Notes:

The long jump

The long jump is a relatively simple event that many youths enjoy performing. In mechanical terms, the approach is a cyclic motion. This means the continual repetition of the same cycle of movement like sprinting. Long jump is a result of the combination and repetition of different movements forms such as takeoff, flight and landing. Horizontal velocity is needed in order to overcome gravity.

Technique

Individual biometer abilities are critical in the development of the long jumper. Over

emphasis on quality leads to slower technical development, inconsistency or injury. When analysing a jump, as a teacher, you must be constantly aware that each action is caused by an earlier action.

The approach

The approach runs allows the athlete to reach the takeoff with maximum controlled acceleration. An efficient, consistent approach used gradual, uniform acceleration.

The Take off

Efficient long jump take offs result from:

- Well - times leg - hip extension.
- Powerful upward swinging of the free leg and arms.
- Powerful lifting of the shoulders.

The above variables are influenced by the jumpers speed and body position in relation to the take-off foot.

The Flight and Landing

Once the jumper breaks contact with the board, the trajectory of the flight curve of the centre of gravity is established and can not be changed. The jumper to maintain the balance and prepare for an effective landing position.

Common Faults and corrective techniques

Fault	Causes	Corrections
Poor speed (Deceleration) at the end of the approach.	Poor acceleration concepts, too long of an approach, fear of upcoming ground forces.	emphasise acceleration development, evaluate energy distribution, correct running mechanics problems, use more progressive workout approach distances.
Sitting at the end of the approach.	Poor sprint mechanics, anticipation of lowering the centre of gravity, poor torso projects.	Correction: Emphasise sprint mechanics and posture at the end of approach runs and during short-run jump takeoff.

Inaccuracy at the check mark or board.	Underdeveloped rhythm skills, poor acceleration skills, faulty steering cur.	Emphasise rhythm and acceleration on approach work and short-run jumps, steer for a different distance distance from the foul line. Takeoff Preparation
Forward lean.	Poor acceleration pattern, poor kinesthetic awareness.	Emphasise approach concepts, adjust approach length, improve feedback techniques on body positions.
Stopping on the pen ultimate step.	Poor posture, faulty foot placement in relation to the centre of gravity, excessive lowering, over emphasis on vertical velocity at takeoff, lack of negative thigh speed.	Improve the learner's concepts of the action with adaptive jumps and short-run jumps.
Excessive push-off from the penultimate step.	Stopping or checking, faulty approach accuracy, poor force - application concepts.	Emphasise rhythm of the last three steps, improve accuracy of runs, educate athlete about force kinesthetics. Takeoff
Foot too far advanced at touch down.	Approach inaccuracy, faulty penultimate preparation, poor posture, over emphasis on vertical velocities.	See previously related items.
Collapsing of takeoff leg.	Lack of pretension in the takeoff leg. Poor negative velocity measures of takeoff leg. Faulty foot position upon impact, inefficient posture.	Review concepts listed in takeoff section in this lesson.
Poor swing movements of the free leg and arms on subsequent flight mechanics.	Systematic eliminate problems by means of short-run jumps.	

Insufficient vertical velocity.	Faulty penultimate preparation, poor takeoff leg recovery, deceleration prior to takeoff.	Review items under takeoff section of this lesson. Flight and Landing
Excessive forward rotation.	Faulty takeoff concept, flight mechanics executed poorly or too late.	Mastering the takeoff posture, practising mechanics in deep pits or off raised takeoff area.
Landing in an upright position.	lack of background lean during first part of the flight, faulty pike concepts, excessive forward rotation at takeoff, fear of falling backward upon landing.	Institute a variety of landing drills and flight drills off short-run jumps.
Falling back on landing.	Timing of knee flexion or slide tilt.	Assign various landing drills, with emphasis on timing.

Lesson 4 : High Jump - The Fosbury Flop

Lesson objectives

The learners should be able to perform techniques of high jump.

Teaching methods:

- Explanation
- Demonstration
- Practical
- Direct instruction.
- Guided discovery

Teaching materials:

- Playground
- Crossbar
- Whistle
- High jump stands
- Mats

Lesson development:

Introduction

Guide the learners to perform warm-up activities. Let one of them be the leader. Follow the procedures.

Lesson body

Step 1 : Let the learners brainstorm on what they know about triple jump.

- Area where it is carried out.
- The technique used:

- Western roll
- Straddle
- Fosbury Flop
- How measuring is done.
- Angles of approach:
 - 300 - 400 - Straddle, Western roll
 - Straight and curved - Fosbury Flop
- How a winner is determined.

Step 2 : Demonstrate to the learners the techniques of high jump. You may use a video show if you have the facilities.

- If you have good facilities especially the landing mats, teach them the Fosbury flop.
- If not, use the sand pit to either straddle or western roll or both.

Step 3 : Guide the learners to discover that in all jumps, each technique involves three phases namely:

- Approach
- Take off
- Flight and landing
- Angles approach in high jump.

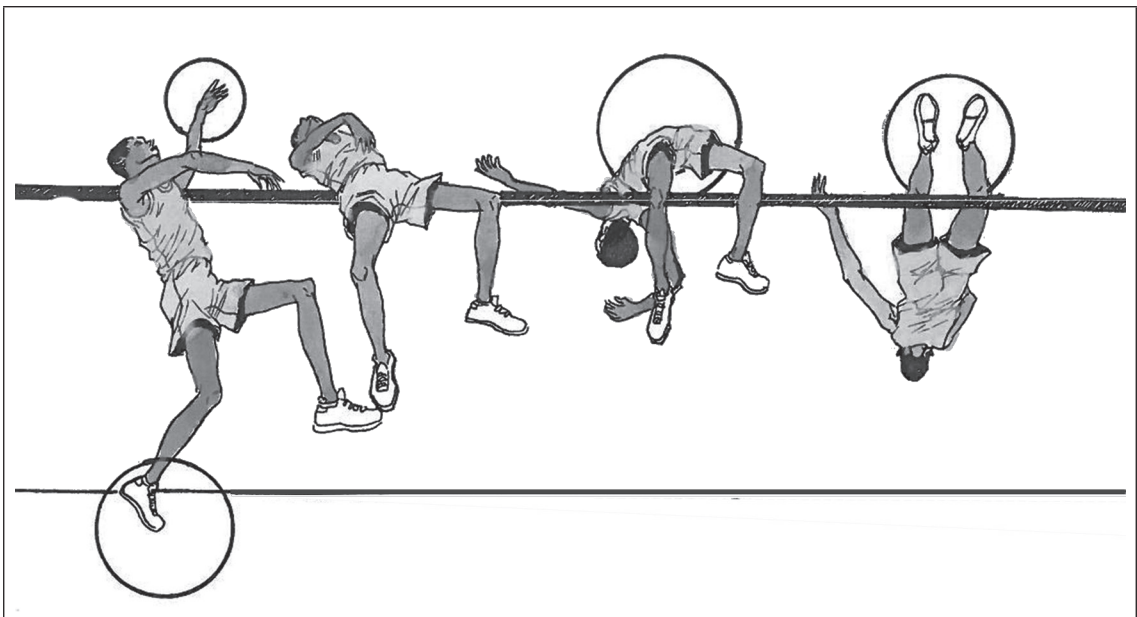

Fosbury Flop

Activity 1: High jump exercises

- Now let the learners carry out high jump following the correct procedures:
 - Approach
 - Takeoff
 - Flight and landing
- The practice should be progressive from the lowest possible up to the height one can manage.
- Emphasise the takeoff is ever on one leg.
- Demonstrate how bar clearance is important. This will help the learners to clear without hitting it

Activity 2: Competitive high jump

- Divide the class in small groups and let them perform high jump competitively.
- Take the records and declare the winners.
- If possible, award all the groups in order to motivate them.

Assessment

- Set exercise and evaluate how the learners perform different techniques of running. (Approach) takeoff, bar-clearance and landing.
- Cool down exercises
Guide the learners to perform cool down exercises. These may include, walking around the track, simple jogging and stretching.

Cool down exercises

Guide the learners to perform cool down exercises. These may include shuttle runs and stretching.

Final discussion.

Discuss with learners focusing on (Reflect, connect, apply)

- Phases of high jump
- Techniques of high jump.
- Factors contributing to good high jump performance.

Lesson 5 : Triple Jump

Lesson Objectives

By the end of the lesson, learners should be able to perform the techniques of triple jump.

Teaching methods:

- Explanation
- Demonstration
- Direct instruction.
- Tape measure
- Practical

Teaching materials:

- Sandpit
- Rake /hoe
- Takeoff board
- Tape measure
- Whistle

Lesson development:

Introduction:

Guide the learners to perform warm up activities. Randomly, choose one of them to be a leader. Let them perform it systematically following the same steps.

Lesson body

Step 1: - Let the learners brainstorm on what they know about triple jump.

- Area where it is carried out.
- The technique used.
- How measuring is done.
- How a winner is determined.

Step 2 : Guide the learners to identify and name the techniques used in triple jump:

- Approach
- Takeoff
- Flight and landing.
- Guide them to tell what is done at each stage:
 - Approach - Running, hopping and stepping.
 - Takeoff – It is done at the takeoff board.
 - No stepping beyond the board.
 - Takeoff board is on one leg.
 - Flight and landing – Safe landing to avoid injuries.
- Let them perform the drill of “ Hop, step and jump “ on the playground before going to the sandpit.

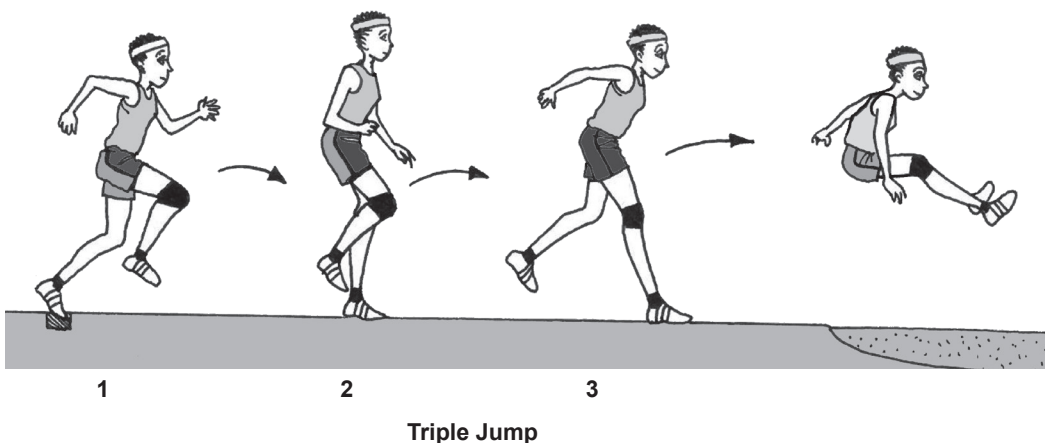

Activity 1: Triple jump exercises

- In small groups, using of the long side of the sandpit, three metres away from it, let the learners "hop, step, and land in the sandpit.
- Let them repeat many times in order to gain mastery of the skill.

Activity 2: Triple jump exercises

- One by one, let the learners perform triple jump using the runway (approach), takeoff and landing in the sandpit.
- Introduce the idea of competition to motivate them.
- Encourage them and correct the errors.
- Measure their jumps and record and finally declare the best performance.
- Award prizes if possible.

Assessment

- Set exercises and evaluate how the learners perform different technique of running, hopping, stepping, jumping and safe landing.

Cool down exercises

Guide learners to perform cool down exercises. Let them jog to and from a marked area, then let them stretch their muscles.

Final discussion

Guide the learners to discuss the following:

- Phases of triple jump : Takeoff, flight and landing.
- Sequence of triple jump: Hop, step and jump.
- Factors contributing to the best performance in the triple jump.
- The importance of triple jump in their daily life and how they will use it.

Lesson 6 : Throwing Exercises (The Shot Put)

Lesson Objectives

By the end of the lesson, learners should be able to put the shot technically.

Teaching methods:

- Explanation
- Demonstration
- Practical
- Direct instruction
- Guided discovery

Teaching methods:

- Playground
- The shot
- Whistle
- Balls
- stones
- Tape measure.

Lesson development:

Introduction

Guide the learners to perform warm-up activities. One of them should lead the activities and others follow. The warm-up should be systematic as in the previous lessons.

Lesson body

Step 1 : Guide the learners to brainstorm on what they know about throws in the athletics and the shot put in particular.

- They have a standard weight.
- They are thrown from distance.
They have standard ways of gripping / holding them.
- They are rules followed when throwing.
- How measuring is done.
- How a winner is determined?

Step 2 : Guide the learners to perform lead up drills using small balls preferably tennis balls.

- Introduce the implement to the learners.
- Men - 7.26 kg
- Women - 4 kg

Discuss the different ways of putting the shot.

- Standing throw
- The glide
- The spin (Rotational)

Go through the phases of putting the shot.

- Starting position
- The guide/ spin/ turn
- The power position
- The put
- Recovery



A learner putting the shot

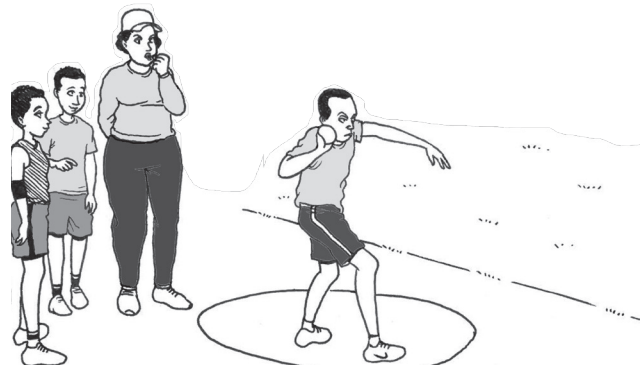

Learners performing exercises of putting the shot

Activity 1: Shot put glide technique

- Tell the learners that you are going to concentrate on the glide technique.
- Demonstration the glide technique to the learners step by step
- Using balls, let the learners practice the glide technique.
- Introduce the real implement and take safety precautions.
- Let the learners practice as many times as possible Supervise, encourage and correct the errors.

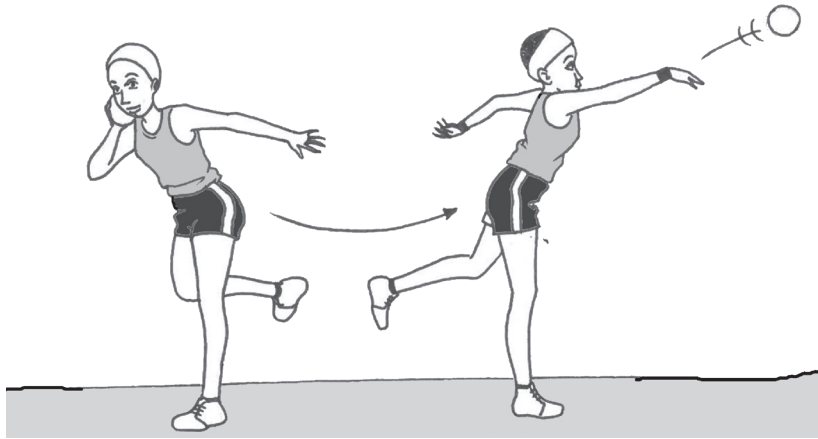

Shot put glide technique

Activity 2: Shot put competition

- Divide the class into small groups.
- Let them compete. Take the measurements and record.
- At the end, declare the winners and give prizes if possible.

Assessment Criteria

- Set exercises and evaluate how learners can put the shot.

Cool down exercises

Guide learners to perform cool down exercises. Let them make star jumps and then stretch.

Final discussion

Discuss with learners focusing for developing values.

- How to grip /hold the shot put (Dirty fingers, clean palm)
- Phase of putting the shot.
- Importance of the recovery step.
- Importance of putting the shot in our daily life.

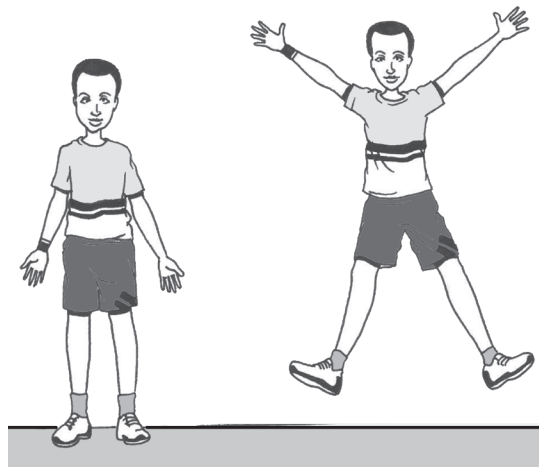

Star jumps

Lesson 7 : The Discus

Lesson objectives

The learners should be able to perform techniques of throwing discus.

Teaching methods:

- Explanation
- Guided discovery

- Demonstration
- Practical
- Direct instruction

Teaching materials

- Playground
- The discus
- Whistle
- Balls
- Stones
- Tape measure.

Lesson development

Introduction

Guide the learners to perform warm-up exercises. Let one of them lead the rest. The warm-up should be systematic as in the previous lesson.

Lesson body

Step 1 : Guide the learners to brainstorm on what they know about discus

- The shape of the discus.
- Types of discus: wood and metal, plastic.
- How it is gripped.
- Likely dangers (safety precautions).
- How measuring is done
- How the winner is determined.

Step 2 : Guide the learners to perform lead up drills using small balls or stones. They can serve better.

- Discuss matters concerning the size of the discus for men and women.

Men ----- women -----

Step 3 : **Activity 1**

Let the learners practice the position of the fingers properly on the discus.

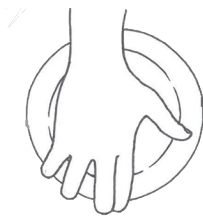

First two fingers together



Fingers apart

- Practice the flip drill to help the thrower develop a feel for the discus release. Have the learners stand in place and flip the discus clockwise 1 to 2 feet into the air. The learner should try to achieve as much rotation as possible. Have the learner work on the speed of release and speed of rotation.

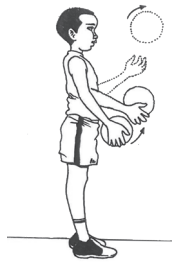

Flip drill,

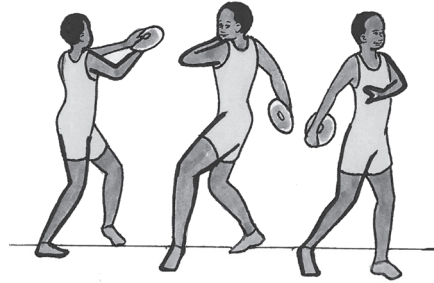

low and high throw

- Practice the bowling drill to emphasise the release of the disc

Activity 2: Discus throwing

- Let the learners carry out the whole sequence of the discus throw:
- Grip, swings, Release and recovery.
- Grip, turns, Release and recovery.

Assessment

- Set exercises and evaluate how learners coordinate the different phases of the discus throw. Award points and finally declare the results.

Cool down exercises

- Guide learners to perform cool down exercises. Let them chase one another in pairs in a limited area to and from. Then they stretch their muscles.

Final discussion

Guide the learners to discuss the following:

- Different phases of the discus throw.
- Factors contributing to the best performance in the discus throw.
- How they perform
- How they will use discus throwing in their daily life

Lesson 8 : The javelin

Learning objectives:

By the end of the lesson the learners should be able to throw the Javelin technically through carrying, withdrawing and releasing

Teaching methods

- Explanation
- Practical
- Guided discovery
- demonstration
- direct instruction.

Teaching materials

- Javelins
- Weighted objects
- Whistle.
- Medicine balls
- Tape measure

Lesson development

Introduction

Guide the learners to perform the warm-up exercises in the most appropriate way. Let them start by jogging around the demarcated area. Then they stretch systematically from the neck to the ankle or vice versa. Finally, strengthen the body with exercises such as pushups, squats, and plyometric.

Lesson body

Step 1 : Let the learners brain storm on what they know the javelin throw. These may include:

- The run-ups
- Withdrawing
- Recovery step
- How to carry the javelin
- Releasing the javelin

Step 2 : Guide the learners to perform the following drills:

Standing throwing drills:

- Standing throws with javelin.
- Standing throws with medicine balls (two handed)
- Standing throws with weighted implements (one handed)
- Overhead shot put throws (4kg and 6kg)

Short approach Throwing drills.

- Three –step, five step and seven step javelin throws.

Approach Drills:

- Sprints with the javelin.
- Cross step running with javelin.
- Cross step dragging a 3-5kg weight.

Other Drills:

- Vertical jumping
- Depth jumping
- Bounding exercises
- Hopping over hurdles or boxes
- Lunges
- Axe swings. (one- and over two – handed)

Step 3 : Guide the learners to tell the sequence of the javelin throw.

- Approach : -Carrying the javelin
- Withdrawing the javelin

- Cross steps
- Releasing the javelin: -Angle of release.
- Trajectory.
- Recovery step (step after throwing)
- Landing of the javelin: -With the head of the javelin.
- Flat with the grip hitting the ground the bounces.

Guide the learners to tell how measurements are taken.

- If it lands with the head, the zero point of the tape measure is pierced at that place and the reading is done at the edge of the throwing arc.
- If it lands flat, the zero point is placed at the point where the grip first hit the ground. Then the reading is at throwing arc.

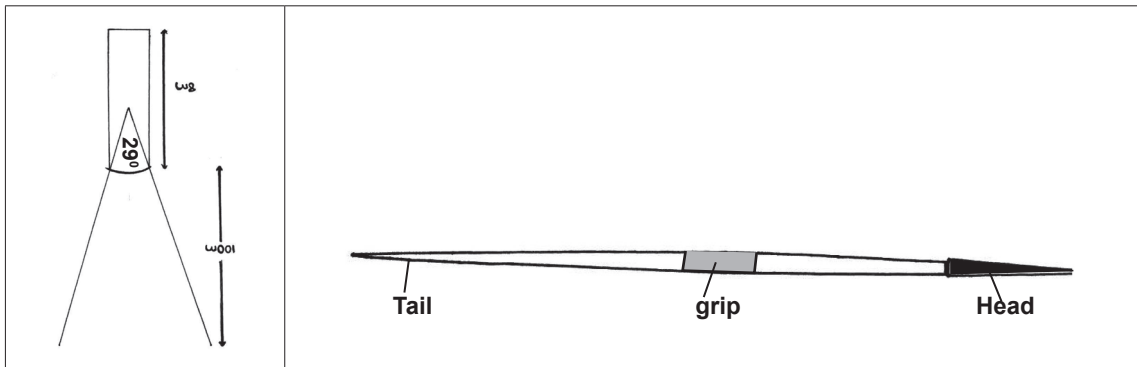

Javelin throw sector

Javelin

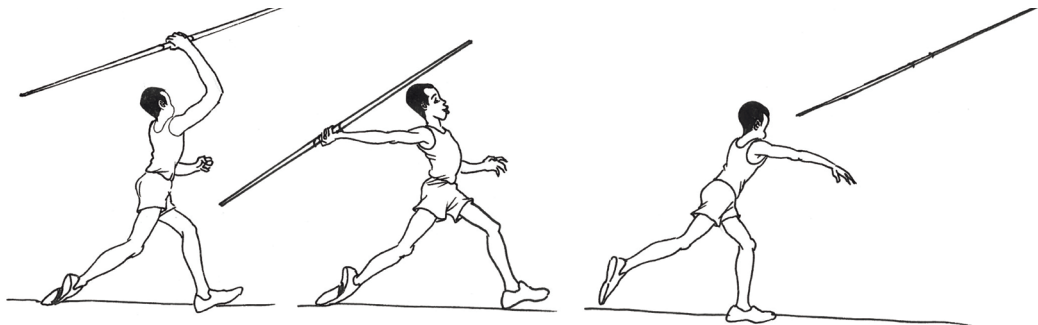

Throwing a Javelin: carrying, withdrawing and releasing

Activity 1: Javelin throwing

Let the learners perform the javelin throw the following the correct sequence.

Cool Down

- Guide learners to perform cool down exercises. Let them jog and touch the ground after the third step. The rhythm should be 1 - 2 - 3 down, then they stretch the muscles.

Final discussion:

Discuss with learners what they have learnt in the throwing of the javelin reflecting and applying the skills in their daily life.

End of unit assessment

- Set the exercises and evaluate how learners will perform running, jumping and throwing techniques.
- Cool down exercises.

Unit Summary 4

In this unit we have learnt various movements in gymnastic done on the ground and using apparatus.

In the next Unit, we shall be learning various techniques used in running, jumping and throwing.

Unit Glossary 4:

- Dynamic** : A process of constant change or progress.
- Stride** : To walk with long, decisive steps in a specific direction.
- Tumbling** : To make handstands and somersaults in the air
- Handstands** : Using the hands to stand.
- Reflect** : Picturing back what you have learnt.
- Connect** : Relating what you have learnt to real life.
- Apply** : using what you have learnt in your long life process.

UNIT 5: FOOTBALL

Content map for Unit 5

Item	Content								
Key Unit Competence	Apply various defensive and offensive strategies and techniques during the football game.								
List of lessons: 8	<table style="width: 100%; border: none;"> <tr> <td style="width: 50%;">1. Attacking systems</td> <td style="width: 50%;">2. Counter Attack</td> </tr> <tr> <td>3. Harassing the opponent</td> <td>4. Mutual Aid</td> </tr> <tr> <td>5. Heading in Defence</td> <td>6. Tack less</td> </tr> <tr> <td>7. Rules in Football</td> <td>8. Football drills</td> </tr> </table>	1. Attacking systems	2. Counter Attack	3. Harassing the opponent	4. Mutual Aid	5. Heading in Defence	6. Tack less	7. Rules in Football	8. Football drills
1. Attacking systems	2. Counter Attack								
3. Harassing the opponent	4. Mutual Aid								
5. Heading in Defence	6. Tack less								
7. Rules in Football	8. Football drills								
Introduction	<p>In this unit you are going to teach:</p> <ul style="list-style-type: none"> - Attacking systems such as 4-4-2, 5-2-3 and 4-3-3 among others. - Counter attack transition from defence. - Exercises of the defensive systems. - Application of rules in a football game situation. - Drills to develop various skills in football 								
Classroom Organisation	Whole class orientation, individual practise, group work, free play, game situations in the playground.								
Equipment required	<ul style="list-style-type: none"> - Football for playing in games. - Whistles for signaling players. - Cones for marking around the playing area. - Stop watches to time durations of activities. - First aid kits to give immediate help to injuries. - Bibs to separate playing teams. - Relevant books to guide the teacher. 								
Activities	<ul style="list-style-type: none"> - 1v1, 2v2 Dribbling exercises - 3v3 Attacking and defending - Small group discussions - Heading the ball - Heading exercises - Tackling exercises - Tackling exercises - Tackling exercises - Implementing rules of football - Practising the rules of football - Football drills - Football drills - Football drills 								

<p>Competences practised</p>	<ul style="list-style-type: none"> - Showing different techniques of attacking and defensive football systems. - Expressing the role of playing in team. - Discussing the role of leadership in protecting their goals. - Attacking and defending in a team. - Appreciating success. - Accepting defeat. - Fair play. - Courage.
<p>Language practise</p>	<ul style="list-style-type: none"> - During warm up sessions. - During brainstorming intervals. - During free play. - During discussion segments.
<p>Vocabulary acquisition</p>	<ul style="list-style-type: none"> - System - Coordination - Spherical - Counter - Tackle - Mutual - Possession - Heading - Collusion - Respect
<p>Study skills</p>	<ul style="list-style-type: none"> - Attacking and defending in a team. - Leadership skills. - Playing in a team. - Dexterity. - Resistance. - Promoting fair play. - Coordination.
<p>Learning outcomes</p>	<p>Ability to apply various systems of attacking and defensive systems during the game.</p>
<p>Cross - cutting issues</p>	<ul style="list-style-type: none"> - Gender: Engaging both boys and girls in all activities. - Standardisation culture, having learners use the same equipment during the lesson. - Peace and values education: learners work together in groups and promoting fair play during games by following rules. - Inclusive education, including the less-abled in activities by adjusting them to suit learners ability.
<p>Assessment criteria</p>	<p>Setting exercises and evaluation of how learners use attacking and defensive football techniques in game situations.</p>

Key unit competence:

Learners will be able to apply various techniques plus defensive and offensive strategies during a football game.

Learning objectives:

Knowledge and understanding

- Show different techniques of attacking and defensive football systems.
- Express the role of playing in a team.
- Discuss the role of playing in a team.
- Discuss the role of leadership in protecting their own goals.

Skills to be developed

- Attacking and defending the team.
- Resistance.
- Dexterity.
- Endurance.
- Coordination.
- Speed and accuracy.
- Force.
- Play in team.
- Promote fair play.
- Leadership role and skills.

Attitudes and values:

- Cooperation.
- Fair play.
- Accept defeat.
- Appreciation success.
- Courage.
- Address.
- Competitive spirit.

Content:

- Exercises of attacking systems
- Exercises of defensive systems
- Apply rules in the game.

Lesson 1: Attacking systems

Lesson objectives:

By the end of this lesson, learners should be able to apply various attacking systems in game situations.

Teaching methods:

- Explanation
- Demonstration
- Observation
- Class discussion
- Pair work
- Group work
- Practical
- Instruction

Teaching and learning materials:

- football
- cones
- playground
- stopwatch
- relevant books
- whistle
- chasubles
- First aid kit
- Bibs
- resource persons

Lesson Development

Introduction

Step 1 : Guide the learners to perform warm-up exercises including jogging, star jumps, skipping, press-ups. Let them stretch and strengthen their muscles systematically.

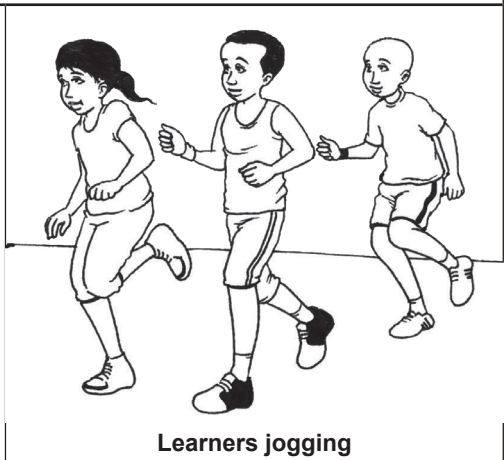
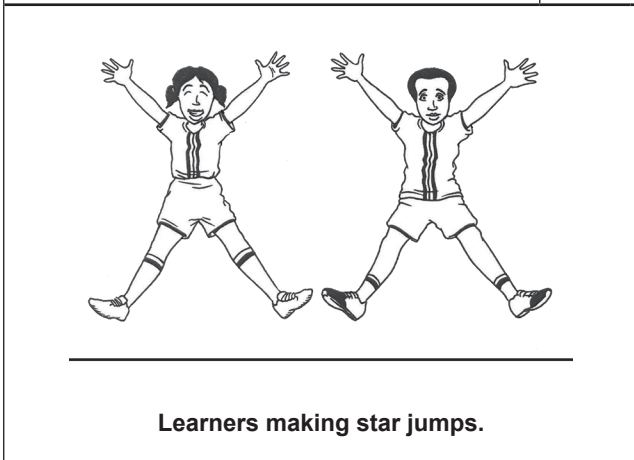
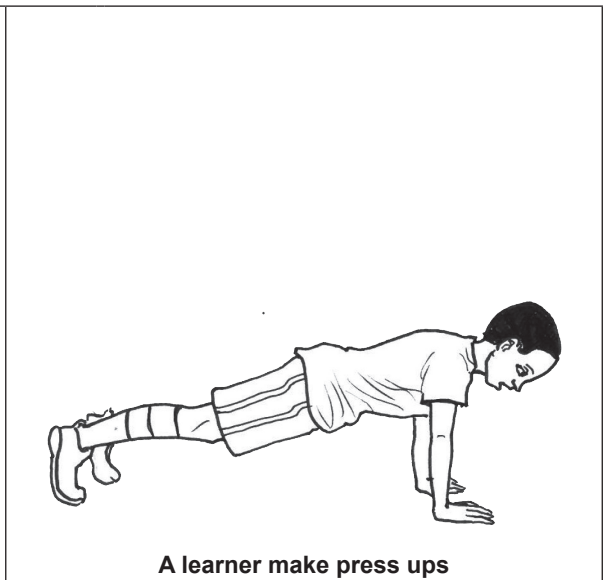
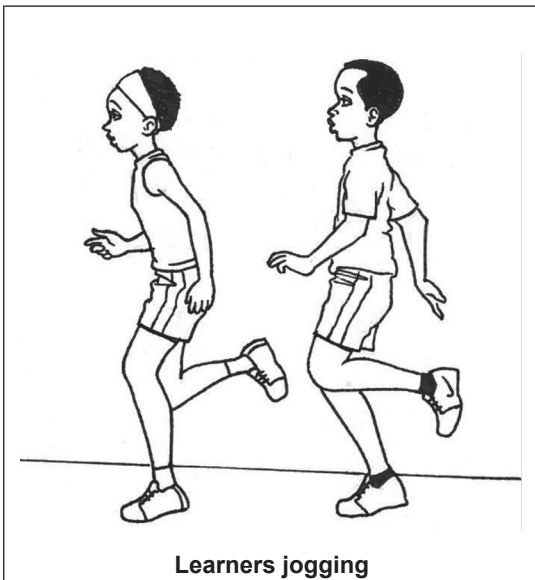

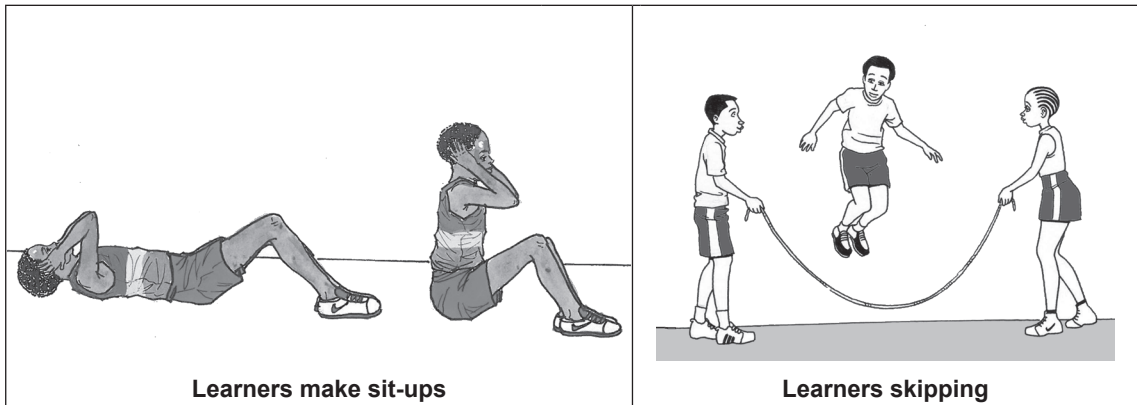

Step 2: - Have learners brainstorm ideas about attacking system.

- Give them a chance to explain and demonstrate what they know about attacking system.

Examples: you may ask them related questions like;

- a) In a 5 : 3 : 2 attacking system, what does each number stand for?
- b) In a 4 : 4 : 2 attacking system, what does each number stand for?

Step 3: Explain that each system is described by three numbers

- The first number represents the number of defenders.
- The second number represents the number of midfielders.
- The third number represents the number of forwards (strikers).

Lesson body:

Attacking system: 5 - 2 - 3

- Explain and demonstrate this attacking system:
 - 5 stands for 5 defenders.
 - 2 stands for 2 mid fielders.
 - 3 stands for 3 forwards (strikers)
- Guide learners to practice the attacking system with clear instructions to the defenders, mid fielders and fowards before and during practice.

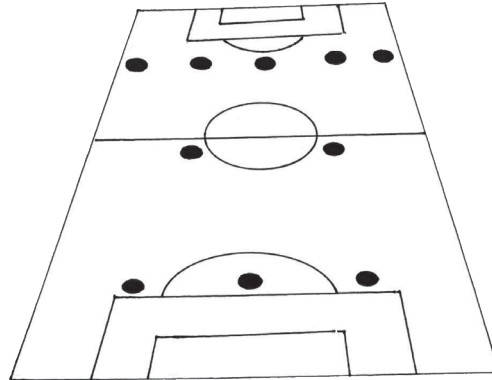

Attacking system 5 - 2 - 3.

Attacking system: 4 - 4 - 2

- In this attacking system;
 - 4 stands for 4 defenders.
 - 4 stands for 4 midfielders.
 - 2 stands for 2 forwards (strikers)
- Guide learners to practise the attacking system with clear instructions to the defenders, midfielders and forwards before and during practice.

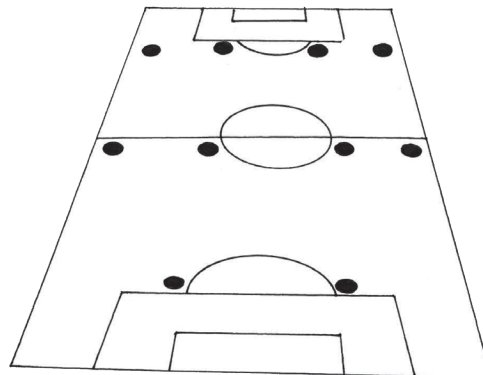

Attacking system 4 - 4 - 2.

Attacking system: 4 - 5 - 1

- In this attacking system;
- 4 stands for 4 defenders.
 - 5 stands for 5 midfielders.
 - 1 stands for 1 forward (striker)

-Guide learners to practise the attacking system with clear instructions to the defenders, midfielders and forwards before and during practice.

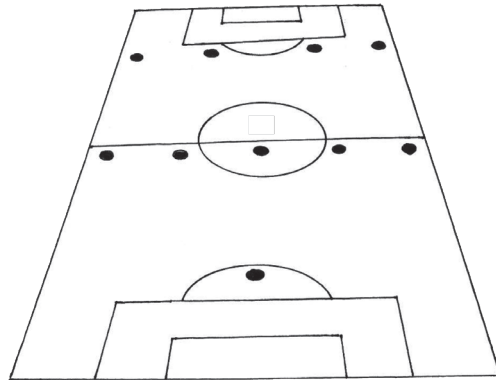

Attacking system 4 - 5 - 1.

Attacking system: 4 - 3 - 3

In this attacking system;

- 4 stands for 4 defenders.
- 3 stands for 3 midfielders.
- 3 stands for 3 forwards (strikers)

-Guide learners to practise the attacking system with clear instructions to the defenders, midfielders and forwards before and during practice.

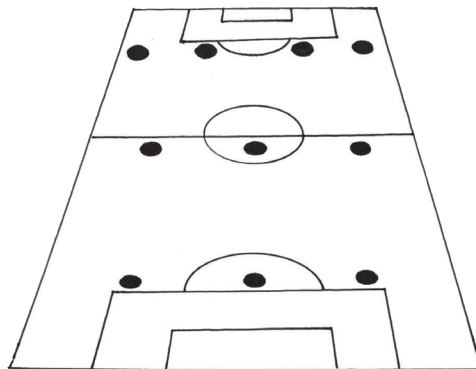

Attacking system 4 - 3 - 3.

Assessment

- Let the learners apply various offensive strategies (attacking systems) in small groups in the game of football.

Cool down

- Guide learners to trot around the field then stretch their muscles systematically.

Final Discussion

- Systems of offensive in football.
- How they perform them.
- The importance of systems in football.
- How they use systems in their daily life.

Additional notes

Table explaining players positions during attacking phases.

Players	Their position on ground during attacking phases
The Defenders	<ul style="list-style-type: none"> • They play behind midfielders. • They usually remain in the half of the field that contains the goal they are defending. • Their major role is to prevent opponents from scoring. • Taller defenders could go into opponents penalty box when their team is taking corner/free kicks to increase scoring chances.
Midfielders	<ul style="list-style-type: none"> • They play between defenders and forwards (strikers). • Their major role is to maintain possession of the ball. • To regain possession of the ball. • To initiate attacking play for their team. • To feed the ball to forwards (strikers).
The forwards (Strikers)	<ul style="list-style-type: none"> • They usually play nearest the opponents goal. • Their major role is to score goals

Lesson 2: Counterattack

Lesson objectives:

By the end of this lesson, learners should be able to make successful counterattacks.

Teaching methods:

- Introduction
- Explanation
- Observation
- Brainstorming
- Practical

Teaching and learning materials:

- Football
- Cones
- Stopwatches
- Chasubles
- First aid kit
- Bibs
- Rooms
- Whistles
- Relevant books
- Playground
- Resource persons

Lesson development

Introduction

- Give them about 3 minutes to warm up.
- Remember to guide them appropriately.

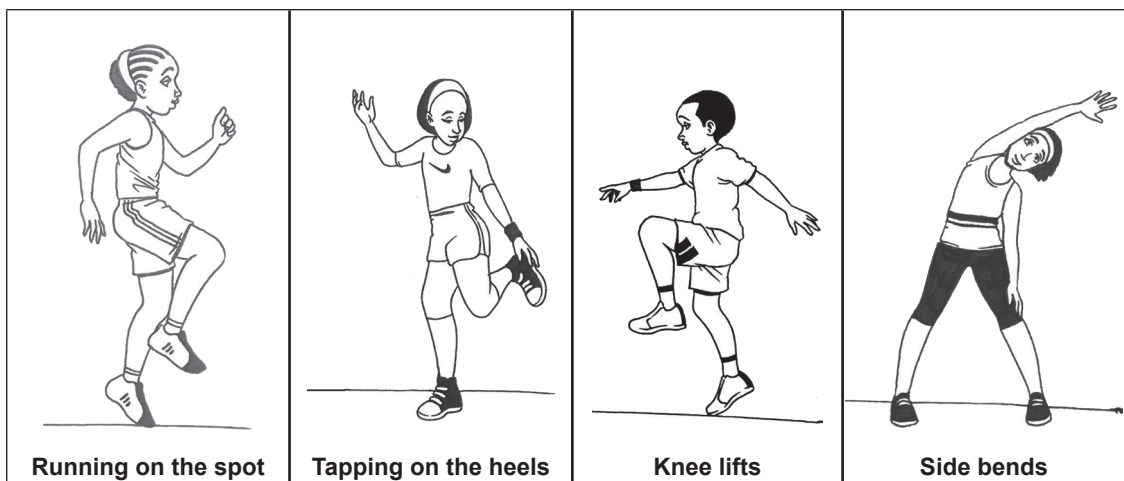

Lesson body

- Step 1:**
- Give learners a chance to review last lesson.
 - Encourage each of them to share what they remember from the previous lessons.
- Step 2:**
- Introduce this lesson; Counterattack.
 - Have learners explain what they think counterattack is.
 - Listen carefully to their responses.

- Give them about 2 minutes to play counterattack according to their understanding.

Step 3: - Explain and demonstrate counterattack.

- Mention that counter attack is an attack made immediately after opponents attack.
- Counterattack also means a quick transition from defence to attack.
- Explaining that most of the times counterattack could occur when:
 - A team has been playing in their end of the field and a player intercepts a pass, wins a tackle or a header, which leads to the team breaking the other way. The other team is caught off guard in a numbers down situation such as a one vs. one, two vs. one or even 3 vs. 2 situations. OR
 - When a team is trying to pass or dribble the soccer ball out of their half and they give the ball away to a defending team playing at high pressure. The defending team wins the ball, takes advantage and attacks very quickly.
- Telling the learners skills they need to have in order to make successful counterattack. They include the following:

Table explaining Key counter attack skills and the player's ability required:

Counter attack skills	Player's ability
Dribbling	Should be able to dribble the ball into space beating players 1 on 1.
Passing	Must be able to make accurate short passes, longer passes and chips.
Shooting	Should be able to shoot with a header and different parts of the leg.

- Emphasizing that counter attack can be very easy if teammates can control, pass, dribble and strike the ball correctly

Step 4 : Introduce fast transition games that help teach players to react quickly as done in counter attack such as 1v1, 2v1, 3v2 and 4v3 (8v8 or 11v11).

Numbers up and numbers down are some of the best games to teach players how to counter or transition.

Activity: 1v1, 2v2, 3v3...

Equipment: Cones, scrimmage vests and cone goals or goals. Explaining and demonstrating how to play:

- Each team should have 5 players or even numbers if available.
- A player dribbles from side "A" with the ball and attacks side "B's" player, so they are now playing 1v1.
- The other four players position themselves in a line next to the goal. The first player will have a ball ready to go.
- Once the attacking player makes or misses a shot, a player from the defending side dribbles on with the ball and plays 1v1 with the attacker that just scored or missed. Same applies when a ball that goes out on the side line.
- The player that has just scored must defend quickly with the attacking player trying to take advantage of the space, attacking quickly - counterattack!
- Encourage the players to use their moves and take the attacker on at speed. Move the game to 2v2 or 3v3 so the players now have the option to pass the soccer ball.
- You can also have learners play numbers down like 2v1 or 3v2 games if you want to really challenge them.

- Step 5:
- Have learners get some free play.
 - Let them play a small football game between 2 teams on their own.
 - Encourage them to counterattack every time after the opponents attack.
 - Praise them for counterattack attempt.
 - Provide feedback to guide them as they master the skill.

- Step 6:
- Give learners a chance to cool down.
 - Ask them to collect all the equipment we were using in this lesson.
 - They may change into their uniforms.
 - Have them go back to their classes.

Assessment

- Let the learners apply various attacking systems in small groups in the game of football.

Cool down

- Guide learners to trot around the field then stretch their muscles systematically.

Final Discussion

- Systems of attack in football.
- How they perform them.
- The importance of these systems in football.
- How they use these systems in their daily life.

Lesson 3: Harassing the Opponent

Lesson objectives:

By the end of this lesson, learners should be able to harass the opponents in defence.

Teaching Methods:

- Introduction
- Brainstorming
- Demonstration
- Practical
- Explanation
- Observation

Teaching and Learning Materials

- Relevant books
- Resource persons
- Observation checklists
- Pens and paper
- Cones
- Scrimmage vests (bibs)
- Whistles
- Balls

Lesson Development

Introduction

Guide the learners to perform warm-up exercises. They should stretch and strengthen their muscles from the neck to the ankle.

Lesson body

- Step 1:
- Greet the class.
 - Make a brief introduction of what you are going to teach. (Harassing the opponents)
 - Have learners fully warmed up in three minutes
 - Guide them appropriately to minimise injuries.
- Step 2
- Have learners form groups of 3 to 4.
 - Ask them to brainstorm ideas on what they think is harassing the opponent in football.
 - Encourage them to note down their ideas.
 - Mention that they should also note down disagreements within the group if any.
 - Let each group present their findings to the class.
 - Invite other learners to contribute to the discussion.
 - Discuss each group's ideas before going any further.
- Step 3:
- Explain harassing the opponent in football. Mention that;
 - Harassing the opponent in this case means, putting too much pressure on the opponents by effectively defending all their attacks.
 - If mastered, it could frustrate scoring opportunities by the opponents.

- Step 4:
- Help learners understand harassing the opponent.
 - Let them practise the skill in a small sided game situation.

Activity: 3 V 3

- Use cones to mark out a small field (playing area).
- Make cone goals for each team (side).
- Explain and demonstrate that;
 - One team will play attack, making 3 consecutive trials.
 - The other team will try to gain possession of the ball (defenders).
 - Each attack should lead to scoring a goal to earn 1 point.
 - If the defenders manage to get the ball, the game will restart and they earn 2 points.
 - Switch teams after every 3 consecutive attacks.

The team that scores the most number of goals wins.

- Step 5:
- End the practice with some free play to make general assessment.
 - Let learners organise themselves into two teams to play a small football game.
 - This is the point where you make little to no teaching.
 - Encourage them to attack everytime they get the opportunity.
 - Praise good attempts to counterattack.
 - Make assessment checklist:
 - Get a piece of paper,
 - Note down all things you want to see learners do in practice.
 - They may include; one touch ball and speed on attack among others.
 - Tell learners to change and go back to class.

Assessment

- Let the learners apply various techniques of harrassing the opponent in small groups in the game of football.

Cool down

- Guide learners to trot around the field then stretch their muscles systematically.

Final Discussion

- Techniques of attack in football.
- How they perform them.
- The importance these techniques in football.
- How they use these techniques in their daily life.

Lesson 4: Mutual Aid

Lesson Objective:

By the end of this lesson, learners should be able to perform a mutual aid in a game situation.

Teaching Methods:

- Introduction
- Explanation
- Oral Questions
- Brainstorming
- Class discussion

Teaching and Learning Materials

- Relevant books
- Resource persons
- Pens and papers

Lesson Development

Introduction

Let the learners perform warm-up exercises. They should stretch and strengthen their muscles systematically.

Lesson body

- Step 1: - Greet the class.
- Make a brief introduction of what you are going to teach. (Today we are going to learn about Mutual Aid)
- Step 2 - Brainstorm with the class Mutual aid by asking them related questions like:
1. What is the meaning of the word Mutual? What about aid?
 2. What comes to your mind when the term mutual aid is mentioned?
 3. What do you think are the benefits of mutual aid.
- Encourage them to note down their ideas.
 - Have them put up their hands to present their ideas.
- Step 3: - Explain mutual aid to the class.

Mutual aid

- It is an agreement between people with same experience to exchange support for a potentially equal benefit.

Example:

- If Ineza sports agrees to sponsor a football tournament. It may decide to give all participants their logo T-shirts, shorts and shoes.

In this case the potentially equal benefit could be;

1. Participants are well dressed and smart.

2. Ineza sports gets to advertise its products.

Benefits of Mutual aid include:

1. Helping partners to build a network of work.
2. Facilitating community fundraising for relief and disasters.

Step 4: - Guide learners practise mutual aid.

Activity: Small group discussions

- Ask them to form groups of 10 learners.
- Let each group discuss mutual aid activity to do in their schools.
- Encourage them to note down any disagreements within the group.
- Mention that their imagination is the limit. Guide them appropriately.
- Give each group a chance to present their activities.
- Discuss each group's ideas.
- Reward the best group by letting the whole class do their activity in the school.

- Step 5: - To make a general assessment, give learners about 2 minutes to reflect on what they have learnt in mutual aid.
- Let them share their ideas with the rest of the class.
 - Let them return to their classes.

Lesson 5: Heading in Defence

Lesson objective:

By the end of this lesson, learners should be able to head the ball in defence during game situations.

Teaching Methods:

- | | |
|-----------------|---------------|
| - Introduction | - Practical |
| - Explanation | - Group work |
| - Demonstration | - Observation |

Teaching and Learning Materials

- | | |
|------------|--------------------|
| - Balls | - First aid kit |
| - Whistles | - Chasubles |
| - Cones | - Relevant books |
| - Bibs | - Resource persons |

Lesson: Development

Introduction

Make greetings and introductions in class.

Have learners suggest physical exercises that are suitable for warm-up. Suggestions could be; Jogging, running, sit-ups, side bends, planks, press - ups among others.

- Let them be fully warmed up in about 3 minutes.
- Guide them appropriately for effective warm-up.

Lesson body

- Step 1
- Introduce the skill Heading.
 - Let learners brainstorm ideas on heading.
 - Guide them by asking related questions they may include;
 - What do you think is heading?
 - Have you ever headed the ball or?
 - Have you ever seen someone heading the ball, where?
 - How is heading done in defence?
 - When should we head the ball?
 - Give learners a chance to head the ball according to their own understanding.
 - Provide feedback by discussing their ideas and demonstrations.



A learner heading the ball.

- Step 2:
- Explain and demonstrate heading the ball in defence to the class.
 - This involves clearing the ball from danger using your head.

<i>When do we head the ball</i>	<i>Why?</i>
<ul style="list-style-type: none"> • If a cross comes in above the player's shoulders. 	<ul style="list-style-type: none"> • Because there is not enough time to control the high ball until it reaches the feet so as to clear it.

- The key to an accurate header is ;
 - Good eye - ball and head coordination.
 - Hitting the ball at the right place and time.

Give an example;

1. When the ball is up in the air and is set to go towards Muteesi's direction, she must move into the line of the ball and position herself close to where she thinks it is going to end up so that she is there right in time to head it towards a teammate or goal.

Teaching points:

Step 4: - Let learners practise Heading the ball.

Activity 1: Heading the ball

- Ask learners to form pairs or small groups of 3 - 5.
- Give each pair or group a ball.
 Explain and demonstrate that;
 - On the blowing the whistle.
 - One player will serve the ball to teammates.
 - He /she must head the ball in the air back towards the server.
 - Teammates will switch roles after every 5 headers.

Progression:

As learners become more comfortable with heading:

- Increase/decrease the distance between players.
- The server may move right or left so that the header must be directed.

Put more emphasis on:

- The timing of the header.
- Heading the ball into air.
- Using the forehead rather than the top of the head.

Step 5: - Gradually increase pressure into practice.

Activity 2: Heading exercises

- Ask learners to form pairs or small groups of 3 to 5.
- Give each pair or group a ball.
- Explain and demonstrate that, when you blow the whistle, they will head the ball back and forth to each other.
- Every time the ball drops down, they loose a point.
- Each pair or group starts the game with 10 points.
- The team with the most number of points wins.

Step 6: - Wind off this lesson with some free play to make a general assessment.

- Let learners play a small football game on their own.
- Encourage them to head all high balls when clearing them.
- Watch them closely and give feedback on what they are doing correctly and what to change the next time.

For example:

- Good job Muteesi on heading the ball with your forehead, but next time jump a little bit higher.

Step 7: - Give learners about 2 minutes to cool down.

- Let them collect all the equipment which has been in use at the playground.
- Let them go back to their classes.

Assessment

Learners show an understanding of how heading the ball in defence is done correctly during practice.

Cool Down

- Let learners perform cool down exercises. These may include; bouncing on the ground as the box the air, then stretch the muscles.



Bouncing on the ground as they box the air

Final Discussion

- Let learners discuss the importance of heading as a defensive technique.
- How they perform it.
- How they use it in their daily life?

Additional Notes

Learners may be scared of heading the ball lest they get hurt. Start off with smaller and softer balls and keep short distances between players. You may gradually increase the distance or use harder and bigger balls.

Lesson 6: Tackles

Lesson Objective:

By the end of this lesson, learners should be able to tackle and win the ball successfully.

Teaching Methods:

- Introduction
- Explanation
- Demonstration
- Practical
- Group work
- Observation

Teaching and Learning Materials

- Footballs
- Whistles
- Cones
- Bibs
- First aid kit
- Chasubles
- Relevant books
- Resource persons

Lesson development

Introduction

Make greetings and introductions to the class.

- Let learners get warmed up in about 3 - 5 minutes.
- Let learners review the last topic.
- Give them about 2 minutes to play heading the ball in defence.
- They may work in small groups or pairs.
- Provide feedback.

Lesson body

Step 1 - Introduce the term *tackle*.

- Let learners brainstorm ideas about what they think a tackle is and how it is done.
- Give them a chance to demonstrate how they think a tackle is done.

Step 2: - Explain and demonstrate a tackle to the class.

Tackling:

This is an act where a defender meets the opponent in possession of the ball to take it away from him/her using the foot.

The main objective in tackling is to:

1. Win the ball from opponent.
2. Dribble the ball away into free space.
3. Pass the ball to a teammate of goal.

- Demonstrate how the block tackle is done.
- State that you will first do it in slow motion.
 - Find a partner to pair with. (An assistant coach or it could be a learner).
 - Stand about 10 metres apart.
 - Have your partner stand still with the ball at his/her feet.



Learners block tackling

- Initiate this demonstration by taking the first step.
- That's when the assistant will take 3 dribbles using the inside of the foot. (Right, left and right again)
- Meanwhile, step towards him to close the gap.
- On the last dribble, he/she is supposed to stop with the ball.
- Then you both contact it using the inside of the foot. Both of you must be conscious to have your bodies over the ball and body contact at the front of the shoulders.
- At this point, the ball should be between both insides of the foot.
- Then either of you should work to get the ball away from the other and head off with it.

Further demonstrate that;

- A player Should not stretch out their legs to reach the ball. Why?
Because it exposes the knee and ankle to possible collusion and damage.

Step 3: - Give learners a chance to practise tackling.
- Break down practice of tackling into pieces

Activity 1: Tackling exercises

- Ask learners to form pairs of (right handed should pair with right handed and left handed with left handed).
- Instruct pairs to keep the ball stationary between inside of their respective feet.
- Ask them to lean forward to contact each other shoulder to shoulder.
- Note that both of them are equals in trying to win the ball.
- Let each of them count each time they win the ball.
- At the end of this activity, the players with most points wins.

Activity 2: Tackling exercises

State that we are now working on timing contract.

- In pairs, have players stand front to front with a ball 2 steps equidistant.
- Explain and demonstrate that;
 - On you signal (blowing whistle) both will simultaneously take one step.
 - They should step up with their left foot and then contact ball with right foot at exactly the same time.
 - Remind them to lock their ankles and lean forward shoulder to shoulder.
 - Have them work to win the ball.
 - The one who is successful gets the ball, should earn a point.
 - Repeat until the timing is done correctly.
 - Caution them not to kick the ball as they could get their ankles twisted.

Activity 3: Tackling exercises

Let's work on contacting the ball.

- In pairs, instruct players to decide who plays offense and defence.
- Instruct offensive players to dribble the ball 3 times using inside of their feet (Right, left right or left, right, left)
- Tell them to stop moving at the last touch.
- Instruct defensive players to step forward.
- Remind them to lock their ankle and contact the ball using the inside of the foot.
- Encourage both of them to work at wining the ball.
- Have them count points on every successful win.
- Let them switch roles after sometime and repeat.

- Step 4: - To make a general assessment, give learners about 5 minutes of free play to practice tackle.
- Have them try to tackle according to their understanding.
 - Guide them appropriately.

- Step 5: - Let them cool down.
- Ask them to collect all equipment that we were using in this lesson.
 - They may change into their uniforms.
 - Let them go back in their classes.

Assessment

Learners should perform exercises on tackling the ball.

Cool down:

- Guide learners to perform cool down exercises. Let them jump as they clap over their heads, then they stretch the muscles

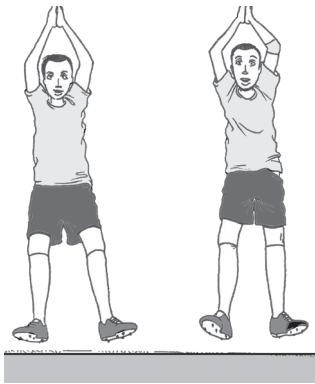

Jumping as they clap over their heads

Final Discussion

- Guide learners to discuss about the importance of tackling in football.
- How they perform tackling.
- How they use tackling in their daily life.

Lesson 7: Rules in Football

Lesson Objectives:

By the end of this lesson, learners should be able to apply rules in a football game.

Teaching Methods:

- Introduction
- Instruction
- Observation
- Explanation
- Demonstration
- Practical

Teaching and Learning Materials

- Footballs
- Resource persons
- Cones
- Relevant books
- Whistles
- Bibs

Lesson: Development

Introduction

- Inviting learners to sit down with you quietly in a circle and greet them.
- Explaining that today they will learn how to apply rule in a game situation.
- Brainstorming this lesson by asking related questions; who can tell me any rules they know in football?
- Giving learners a chance to warm up as they explore the various rules they know.

Activity 1: Implementing rules of football

- Asking learners to choose a referee.
- Telling them to divide themselves into two teams.
- Explaining and demonstrating that the referee will blow the whistle to start this game, and they will play a small football game following their own rules they know.
- Encouraging them to listen to the referee because he has the final say in this session.

Step 1: – Telling learners that FIFA, is the International Federation of Football that holds the official rules to the game

- Mentioning that not all rules set by FIFA are standard, some of them can be modified to suit players with disabilities, female soccer players, veteran players (over 35 years of age), and younger players. For example:
 - The size of the field of play . The size, weight and material of the ball
 - The Width between the goal posts and height of the crossbar from the ground
 - The duration of periods of play . The number of substitutions
 - Explaining the rules that apply in a football game. They include:

Number of players:

- The game is played between two teams of 11 players each. Ask learners to tell you which teams Rwanda national team has beaten in this year.
- This can be modified by having two teams of an equal number play the game. For example 3v3, 4v4 and 5v5 among others.
- Players are not allowed to use equipment or wear anything which is dangerous to themselves or another player including any kind of jewelry such as necklaces, earrings, nose rings and belly rings among others

The ball:

- It is spherical in shape
- Size 5 is the standard size for professional and adult soccer players but size 4 or 3 can be used for beginner or younger players.

Equipment:

- The basic equipment required for a Football game includes a jersey or shirt, shorts, stockings, shin guards and footwear

Substitutions:

- Officially, only 3 substitutes are allowed per game
- A substitution can only be performed when the ball is not in play and your team has the ball. For example; when it's a throw in for your team, or goal kick for your team.

Starting the Game;

- The game is started or restarted at the centre of the field.
- The team which kicks off passes the ball forward to a teammate at the referees signal.
- The opposing team is not allowed to enter the centre circle until the team kicks off.

Game in play:

- As long the ball stays in the field the game is in play.
- It also remains in play if the ball still has contact with the end lines of the field.
- Contact with the goalpost, corner flag, and referee back in the field is still considered in play.
- Exception is when the referee blows his/her whistle for an infraction or offside.

Out of play:

The ball is considered to be out of play if it crosses the end lines of the field

- If the ball crosses the side line it is a throw in, the team who did not touch the ball last before it crossed the line gets the throw in.
- If the ball crosses the goal line two things may happen. If the team that is defending that goal line touches it out it is a corner kick. If the team attacking that goal kicks it out it is a goal kick

Offside;

- A player is in an offside position if he is nearer to his opponents' goal line than both the ball and the second last opponent.
- In this case, the ball is given to the opponent team.
- The offside rule applies when the ball is kicked, not when the player receives the ball.

Goal;

- The point of the game is to get the ball into opposing teams' goal (scoring)
- The team that scores most goals after the specified time wins the game
- The ball must cross the goal line to be counted as a goal, if the ball still has contact with the goal line in the inner part of the goal it is not a goal.

(This applies if the ball is in the air as well).

How long can the game be?

- Officially the game is 90 minutes long.
- It is broken down into two halves of 45 minutes with a 15 min half time break

Handball;

- A player is not allowed to intentionally use any part of between his/her fingers (including nails) to his/her upper arm to contact the ball, it is considered a handball.
- A ball that is kicked and hits a player's hand or arm is not a handball
- Only the goalkeeper can use their hands in contact with the ball.
- The goalkeeper is not allowed to use their hands if the ball was kicked back to them intentionally by any of his/her teammates.

Fouls and punishment;

A player cannot kick, trip, jump at, charge, strike, push, hold, or spit at an opponent, is regarded as fouling.

- The normal consequence of a foul is a direct kick for the opposing team.
- Punishment is given in Football with either a yellow or a red card depending on the severity of the foul.
- If a player is given two yellow cards in the same game, that is equal to a red card.
- A red card can be given at anytime without the player first receiving a yellow card.
- When a player gets a red card, they must leave the game and he/she cannot be replaced.

Penalty Kick;

- A penalty kick results from a contact foul or handball by the defending team within the penalty area (the large box on either end of the field).
- The ball is placed on the penalty spot or mark, 12 yards in front of the center of the goal.
- All players must remain outside the penalty area and the penalty arc until the ball is kicked.
- The goalkeeper must have both feet on the goal line until the ball is kicked.
- If after the ball is kicked, it rebounds off of the keeper and stays on the field, the ball gets back in play and anyone can play it.
- The person who kicked the ball cannot play it until the ball is touched by another player otherwise he/she will be called for two touches

Step 2 : Now that learners have all the basics for applying rules in a game situation, finish practice with a small sided 4v4 game.

Activity: 2 Practising the rules of football

- Telling learners to divide themselves into groups of 4
- Asking players to apply what they have worked on in today's practice in their own way.
- Encouraging them to select their own referee if they want. (Give him/her the whistle to do this role well)
- Free play with little to no coaching is a great chance for learners to understand through peer assessment.
- Use the above activity to make a general assessment.
- Observe learners' understanding and application of rule in the game to draw your conclusion of whether they have mastered them or not.

Assessment

- learners should be asked to apply the rules in the game situation.

Cool down:

- Guide learners to perform cool down exercises. Let them run downhill/slope. If not, they jog around then stretch their muscles.

Final Discussion

- Guide learners to discuss about the importance of :
 - Rules and instructions during a game situation.
 - Fair play.
 - Team spirit.
 - How rules of football help us in our daily life.

Lesson 8: Football drills

Lesson objective:

Learners should be able to perform and create various drills in football.

Teaching methods:

- Introduction
- Explanation
- Demonstration
- Instruction
- Observation
- Practical

Teaching and Learning Materials

- Resources
- Relevant books
- Resource persons
- Stopwatches
- First aid kits
- Bibs
- Cones
- Balls
- Whistles

Lesson development

Introduction

Making greetings and introductions to learners standing in a designated area.

- Giving learners a chance to review rules of a football game
- Asking each learner to share what they remember about rules of a Football game.
- You may ask them related questions to prompt their thinking. For example, when is a free kick awarded? When is the ball out of play?
- Telling learners what we are going to learn in this lesson, Football drills. In a brainstorming session, ask learners to tell you any drills they know.
- Guide the learners to perform warm-up exercises.

Step 1 :- Introduce to learners a game (drill) about defending in a group to improve and strengthen their defending ability.

- Going ahead to tell learners that without a strong defence, your team will never make any good results.

Activity 1: Football drills

- Dividing players into two teams.
- Separating them into defenders and attackers. Ensure that attackers have two more players than defenders.
- Giving each attacking player one ball.
- Using cones or anything similar to create a rectangular playing area.

- Explaining and demonstrating that:
 - The attacking team should try as much as possible to keep possession of the ball by dribbling and controlling it inside the rectangle.
 - The defending team should try to mark as many players as possible with an aim of dispossessing the ball, there will always be two unmarked players.

Note:

Encourage defenders to try and make it harder for attackers to find passing alternatives.

- Having players switch roles after a certain time.
- Step 2:
- Explaining and demonstrating the turnover drill.
 - Mentioning that this drill will help strengthen the team's defence and the way they construct a counter-attack.
 - Setting up the drill by:
 - Dividing learners into attackers and defenders.
 - Deciding whether defenders will play in either a 3 or 4 line defence.
 - Attackers should play in groups of three and their aim is to pass the ball past defenders and finish with a shot on goal.
 - Explaining that:
 - You will give the ball to attackers and they have to dribble through the defence and score without losing the ball to win a point.

- The defenders will have four defenders and a goalkeeper to make it harder for attackers to score.
- Defenders should try as much as possible to gain possession of the ball in order to win a point.
- Teams will switch roles after a certain time.

Step 3: - Introduce a drill that will focus on all aspects of the game such as passing, dribbling and scoring among others.

Activity 2: Football drills

Setting up this drill:

- Using coners or anything similar to mark a squared played area.
- marking a triangle in the middle of the playing area with sticks or flags or cones to serve as a goal.
- Placing a goalkeeper inside the triangle.
- Dividing learners into two equal teams of 4v4 or 5v5.

Explaining that when the game begins:

- Both teams will attack the three sided goal.
- The goalkeeper should defend all the three sides of the goal.
- If a team scores a goal, a point will be awarded and the ball will be in play on the other side of the goal.
- If the goalkeeper makes a save, he will have to throw the ball far away from the players.
- For a goal to count, the ball must cross through the goal not higher than the top of the flag or training stick.

Activity 3: Football drills

Variations:

- Telling learners to shoot at goal after a certain number of passes.
- Playing one or two touches on the ball.

Teaching Points

Encourage players to communicate and work together as a team in order to quickly off-balance the defenders and catch the goalkeeper unaware.

Step 4 :- Giving learners a chance to create their own drills.

- Encouraging them to include various aspects of the game including passing, receiving, moving with and without the ball, defending, attacking and finishing among others.
- Guiding them appropriately to ensure safety.

- Giving them free play time to play their own drills, make very little to no teaching in this lesson.
- make a general assessment, observe how they perform various skills as you note down your conclusion.

Cool down

- Guide learners to perform cool down exercises. Let them walk around the activity area, stretch and finally strengthen their muscles.

Final discussion

- Discuss with the learners what they have learnt about the defensive and offensive strategies and techniques of football.
- How can they apply them in their daily life?
- What is the importance of these strategies and techniques to this learners?

End of Unit Assessment

Set exercises and evaluate how learners perform the defensive and offensive strategies and techniques in the game of football.

Unit Summary 5

In this unit we have learnt about attacking systems, defensive techniques and application of rules in the game situation.

In the next Unit, we shall be learning:

- The different skills of attacking and defending in volleyball.
- To interpret the rules of a volleyball game.
- To discuss the qualities of a good leader.

Unit Glossary 5:

System : In organised way of doing something.

Counter : Transition from defence to attack.

Mutual : Interest held in common by two or more parties.

Heading : To hit the ball using the head.

Coordination : Ability to use different parts of the body together efficiently and smoothly.

Possession : To have the ball.

Spherical : Round in shape like a sphere.

UNIT 6: VOLLEYBALL

Content map for Unit 6

Item	Content
Key Unit Competence	Use different defensive and offensive volleyball techniques in various game situations and apply basic rules.
List of lessons	4 - 1. Service 2. Passing 3. Defence 4. Attacking systems
Introduction	Volleyball is a ball game played by two teams of six players each on rectangular court, 18 m by 9 m. The court is divided into two parts by a raised net. The ball is played with hands, hitting it back and forth over the net.
Classroom Organisation	Whole class orientation, then group practise in different volleyball courts.
Equipment required	Football, Whistles, Cones, Goals, Chasubles and scoresheet
Activities	Learners practise the drill for under arm service. Place a target on court for players to aim at. Learners work in pairs on throwing the ball. - Underarm serving drill - Digging drill - Blocking drill
Competences practised	- Knowing the meaning. - Identifying. - Listening. - Appreciating
Language practise	- Brainstorming, instructing, discussing and demonstration.
Vocabulary acquisition	- Flip - pivoting - antenna
Numeracy	- Counting points on every goal scored. - Counting attempts to score.
Study Skills	- Attack, defending endurance. - Playing in a team speed.
Learning outcomes	Ability to develop volleyball basic techniques.
Cross - cutting issues	- Peace and values education - Inclusive education
Assessment criteria	Setting exercises and evaluate how learners develop various skills of defensive systems.

Key unit competence:

Learners will be able to use different defensive and offensive volleyball techniques in various game situations and apply basic rules.

Learning objectives:

Knowledge and understanding

- Demonstrate different skills of attacking and defending.
- Interpret the rules of the game.
- Discuss the qualities of a good leader.

Skills to be developed

- Attacking and defending a team leadership.
- Playing in a team.
- Resistance and dexterity.
- Endurance.
- Coordination.
- Speed and force.

Attitudes and values:

Importance of good leadership to a team.

- Cooperation.
- Fair play.
- Accepting defeat.
- Appreciate the success.
- Resilience.

Lesson 1: Service

Lesson objectives

By the end of this lesson learners should be able to serve the ball through various techniques.

Teaching Methods:

- Introduction
- Explanation
- Brainstorming
- Observation
- Group work
- Practice

Teaching and Learning Materials:

- nets
- balls
- whistles
- Cones
- Stopwatches
- First aid Kits
- Playground

Lesson: Development

Introduction

Greeting the learners. Instructing one of the learners to lead others in warm-up exercise.

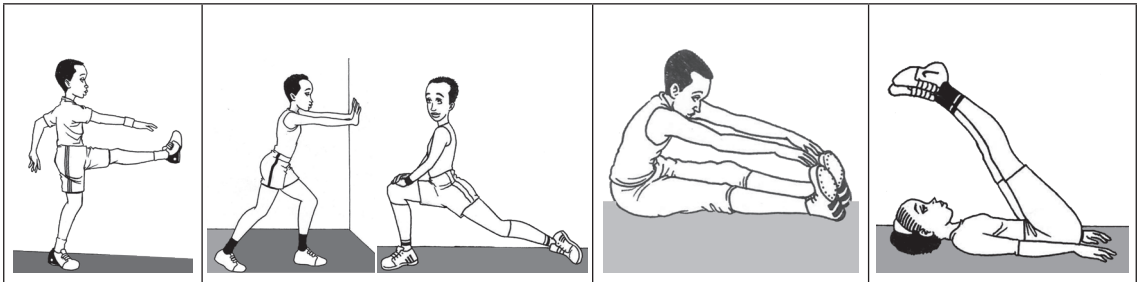

Showing volleyball player carrying out warm up exercises to flex their muscles

- Step 1 : Asking learners to mention the different techniques required to play volleyball basing on the knowledge of the previous classes.
- Through guidance, remind learners that service is a method by which the ball is put into play.
 - Emphasising to the learners that serving is done performed by the right hand back-line player.
 - Ask learners basing on the knowledge they have of the previous class the position of the server.
 - Demonstrating to the learners the steps to be followed by a player while serving.
 - She/he hits the ball with his open or closed hand or any part of the arm, in order to send the ball over the net into the opponent's court.
 - Server standing behind the backline and strikes the ball having tossed it into the air.
 - The player must strike the ball with one hand and the ball must not be resting on the other hand.
 - After striking the ball, the player may enter the field of play.
 - The service is considered good if the ball passes over the net and between the antennae.
 - It must be immediately after the referee has blown the whistle.
 - A player continues to serve until his team commits a fault.
 - Explaining to the learners that the referee signals change of service when the following faults of service happens.
 - The ball passing under the net.
 - The ball touching the antenna.
 - The ball passing behind the antenna.
 - The ball touching a player of the serving team before entering the opponent's court.
 - The ball touching any object before entering the opponent's court.
 - When serving is made by the wrong player.

Step 2 : Teaching learners that there are different types of serving. For instance;

- The player serving does not release the ball before serving.
 - Underarm service.
 - Tennis. (overhand service)
 - Hook or windmill service.
 - Floating service.
- Underarm service
- Explain to the learner that underarm service is the simplest service and the most reliable. technique in volleyball.
- Guide the learners that underarm is most recommended for beginners and girls.

Teaching points

- Explaining and demonstrating to the learners, the steps required in performing underarm service.
 - Holding the ball on the outstretched hand at waist height. The ball should be in front of the striking arm.
 - Stand with one foot in front with knee flexed.
 - Keep the weight on the back foot.
 - Swing the arm well behind the body almost brushing the thigh.
- Flip the ball into the air as you swing the striking arm, transfer the body weight forward straightening the knees.
- Contact the ball with the heel of the hand or the wrist or the inside of the clenched fist.

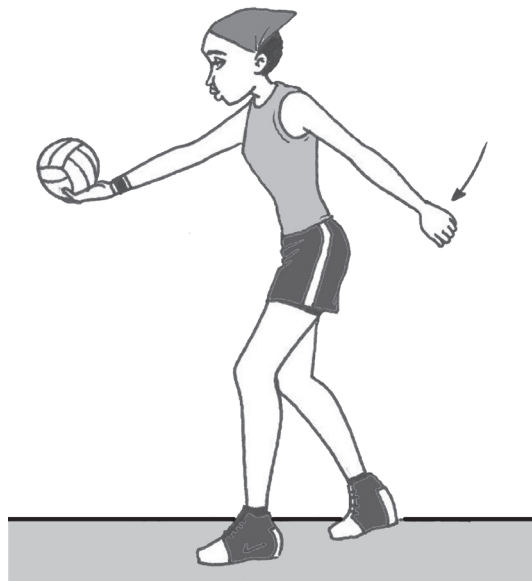

Exercises of an underarm serve

Activity 1: Underarm serving drill

- Let learners practise the drill for the underarm service.

Divide the class into groups, each group lines up along each side of the net on court.

Each group starts from a distance of 3 m from the net, The players go on increasing the distance away from the net until such a time when they are along each backline.

- Place a target on court for players to aim at.

- Divide the court into areas with various marks for point hit. If the ball hits area with 2, you score 2 points see figure below.

Area 1	Area 2	Area 3
3	3	3
2	1	2
2	1	2

That will help

Instruct learners to use the drill. Give so as to have enough time to master the low front kick.

- Instruct learners to stretch the backs by forming a bridge - like shape. Learners lie on the floor, bend knees, feet placed on the floor.

Assessment

Setting exercises and evaluate how learners develop and use various skills of serving in the game of volleyball.

- underarm service
- tennis service

Cool Down

Guide the learners to perform cool down exercises. Let them walk around the volleyball court 3 times and then they stretch the muscles.

Final Discussion

Learners will discuss and demonstrate what they have learnt on performing a serving skill in volleyball.

How these serving skills help them in their daily life.

What is the importance of serving skills in our daily life?

Lesson 2: Passing

Lesson objective

By the end of this lesson learners should be able to receive the ball and pass it in return.

Teaching methods:

- Introduction
- Brainstorming
- Group work
- Pair work
- Explanation
- Observation
- Practice

Teaching and learning materials:

- Net
- Whistle
- Stopwatch
- Playground
- Balls
- Cones
- First aid Kits
- Chasuble

Lesson Development

Introduction

Instructing learners to pick all sharp instrument from the volleyball court.

- Reminding learners that warm-up is part of the learning process.
- Identifying one of the learners and later telling him to lead others in warm-up exercises lasting 5 minutes.

Lesson body

- Step 1 : Explaining to learners that passing is a technical skill in attacking.
- Further inform learners that passing is an important skill in volleyball.
 - Teach learners that once passing is not demonstrated well, getting a successful attack will be hard.
- Step 2 : Guiding learning on the need to observe each and every step as he demonstrates the dig pass.

The Dig Pass

- Guiding and explaining to learners the technique of digging in volleyball. Emphasise that digging is the act of receiving the ball on the outstretched forearms.
- Bringing to the attention of learners that the following are the functions of a dig during the game.



Position to receive and pass the ball in turn

- Used to play the ball which is too low
Which is too fast
- Which is too far to the side used to answer a service.
- Used to receive a spiked ball.
- Used to retrieve a ball from the net.

Note:

- The dig must take the speed out of the ball.
- The action of the dig should not increase the speed of the ball.
- Swinging arms will destroy the purpose of reducing the speed of the ball.
- Quick and easy method of gripping the hands will make it easy to form a broad platform of the forearms.

Teaching points of a Dig pass:

- Step 3:
- Instructing and demonstrating to learners the steps required to perform a dig pass.
 - Move in a position so that the ball will be received between the shoulders.
 - Assume a stable base with knee flexed and facing the direction of the intended pass.
 - Extend the hand in front of the body keeping them straight by locking the elbow.
 - Hold the hands together and bend the wrists down.
 - Contact the ball with the fleshy part of the lower arm.
 - Use a steering movement rather than arm swing.
 - Further explaining to learners that passing technique starts with foot placement.
 - A player must be in athletic position and properly align the arm.
 - Emphasising need to bring arms together straight and away from the body.
 - Let the forehand create a platform giving the ball clear contact.
- Step 4:
- Instruct the learners to practise drills for the Dig pass.

Activity 1: Digging drill

1. learners work in pairs. One person throws the ball while the partner digs it back. This should be repeated to a count of 10 after which they change roles.

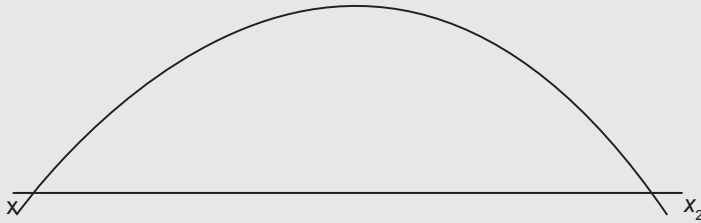

2. Learners should do as in 1 but this time the ball thrown should not reach the partner who is expected to move forward to dig and later return to original position. Learners should repeat the count of 10 and then after change roles.

Assessment

Setting exercises and evaluate how learners develop and use various skills of attacking and defensive of the organisation system of the game.

Cool down

Let the learners jog around the activity area, stretch and strengthen their muscles.

Final Discussion

Learners will discuss what they have learnt about positioning to receive the ball and pass.

Discuss with learners the various techniques of serving the ball in the game of volleyball.

Lesson 3: Defence

Lesson objective

By the end of this lesson learners should be able to play defensive in game situations.

Teaching methods:

- Introduction
- Brainstorming
- Group work
- Pair work
- Explanation
- Observation
- Practice

Teaching and Learning Materials:

- Net
- Whistle
- Stopwatch
- Playground
- Balls
- Cones
- First aid Kits
- Chasuble

Lesson Development

Introduction

Welcoming and greeting learners.

Instructing one of the learners to lead others into warm up exercises: Jogging, running here and there, stretching, exercise twisting. These exercise should not exceed 7 minutes

Lesson body

- Step 1: - Commanding learners to have clean up exercises of picking and identifying sharp instruments so as to ensure safety of the learners.
- Step 2 : - Explaining to the learners that defensive system is an action made to block or intercept the opponent and hence stop them from scoring a goal.
- Guide learners to know that blocking as a defensive system in volleyball is a weapon against spike.
 - Explain to learners that blocking done by the front line players who do it by jumping vertically and place a wall of hands in the path of the ball. The purpose of putting up a wall is to deflect (bounce) the ball into the opponents court.
 - Guide learners to know that blocking as a first line defence.
 - Explain to learners that a team may use two or three players to block. It is only on rare occasions that a team may use one player to block.
 - Further, explain to the learners that blocking done while the players is in position at the net.



A defence of blocking by two players

Note:

Any attempt to block is considered actual only if the ball contacted by any of the blockers. The team that has had an actual block shall have a right to make successive contact. And the hands of the blockers may reach over the net, but should not contact the ball over the opponent's court.

Step 3: - Guide learners through the steps of blocking in volleyball.

Teaching points:

- Stand close to the net.
- Watch the ball as it leaves the setters hands.
- Predict where the ball will be attacked from.
- Identify the opponents attacker.
- Observe the opponents approach.

- Determine his point of attack and the angle through which he will most likely strike.
- Place arms at the shoulder level.
- Jump from the spot.
- Jump after the attacker has done so.
- Thrust the arm into the air.
- Place arms apposite the attacking arms of the opponent.
- Let hands led over the net and in over the opponent's courts.
- Make the ball over the opponent's court.
- Make the contact at the pick of the jump.



Single blocking in volleyball

Step 4: - Remind learners that when the attack is at the wing, the opponents use two blockers, but when it is in the middle they use three blockers. In case the team is using front attacks, the opponents may use one blocker.

- Explaining to the learners the importance of block in the following ways:
 - Block leader: Tell learners that this is a player whose responsibility is to see that the block is in the right position. He/she coordinates the actions of blocking and avoids blockers bumping
 - Positioning: Teaching learners that a player should watch out on their positioning. Blocking players should watch the blocker. His body should be positioned in relation to the ball. And his body with the inside of the hand. Should be in the path of the spiker's striking hand.
 - Timing: Let learners know that the blocker should take-off just after the smasher, so that he will be at his maximum height when the ball is contacted.
- Withdraw the hands from the opponent's court.
- Avoid touching the net.

Activity: 1 Blocking drill

- Instruct learners to perform blocking as a defensive skill in volleyball in groups of 5 to have mastery of the skill.
- During the drill learners should ensure that the ball does not fail in one's camp and which ever side achieves the skill for more minutes becomes the winner.

Assessment

- Setting exercises and evaluate how learners develop various skills of defensive systems.

Cool down:

- Guide learners to perform cool down exercises. Let them walk around the volleyball court three times then stretch the muscles.

Final Discussion:

- Learners will discuss what they have learnt about defensive systems in volleyball.
- Discuss various techniques of serving the ball in volleyball.
- Discuss the importance of receiving and passing the ball in volleyball.
- What are the values of volleyball techniques in our daily life?

Lesson 4: Attacking systems and Basic Rules

Lesson objectives

By the end of this lesson learners should be able to perform the different attacking systems in game situations while following the basic rules.

Teaching methods:

- Introduction
- Brainstorming
- Group work
- Pair work
- Explanation
- Observation
- Practice

Teaching and learning materials:

- Net
- Whistle
- Stopwatch
- Playground
- Balls
- Cones
- First aid Kits
- Chasuble

Lesson: Development

Introduction

Welcoming learners and greeting them.

Commanding learners to perform warm-up exercises.

Let them stretch and strengthen their muscles systematically.

Lesson body

- Step 1
- Explaining to learners that the lesson to be learnt is smashing or spiking which is a technique of attackers.
 - Demonstrating to learners that a volleyball player is expected to do the following:
 - Jump as high as possible near the net.
 - Hit the ball strongly down into the opponents court.
 - Bringing to the attention of learners that smashing or spiking is fairly a difficult technique. It is for that reason that a lot of practice and body coordination should be accorded to it.
 - Guiding learners to consider the following requirements so as to master the technique well.
 - A fast sprinter. (runner)
 - Good timing.
 - Quick thinking.
 - Plenty of practice

Through brainstorming and guidance drive learners on the essential requirements for good spiking.

- Good A tall player.
- Having good vertical jump.

Explain to the learners that spiking can be divided into four stages:

- (a) The approach to the net.
- (b) The takeoff.
- (c) The flight body movement in the air.
- (d) The striking action.

Step 2: Leading learners into the steps of spiking (smashing).

Teaching points:

- Stand 3 - 5 steps away from the net.
- Accelerate the takeoff position.
- Put both feet shoulder width apart.
- Flex the knees.
- Swing the arms behind.
- Take-off from both feet with vigor.



Player demonstrating smashing depict jumping as a sports activity.

- Rock over heels.
- Swing arms forwards and upwards as strongly as possible.
- Extend the hip, knee and ankle joints vigorously.
- Flex the striking arm at the elbow with the elbow pointing forward.
- Arch the back.
- Move the trunk towards the ball.
- Keep the arms at ear and move it upwards and forwards.
- Keep fingers together and wrist loose.
- Contact the ball with an open hand but sharp.
- Rotate the elbow outwards.
- Land on the ball off the feet.
- Avoid touching the net.

Step 3 : The drill below is given to enable learners have practice on the spike. This practice once demonstrated and guided well will enable learners to get a good grounding technique as well as satisfying the learners urge.

- Practise the approach stand in a file facing the net. One by one makes a 3-step approach and jump to spike an imaginary ball at position 2, 3 and 4. This is done repeatedly to the court of 5 repetitions.
- Further explain to the learners that serving is done at the beginning of each rally. And it is done by the right hand back-line player who is in position 1.

Step 4 : Explaining a few basic rule of volleyball playing to the learners. Like any organised institution or society rule are vital for the volleyball. Promotion of fair play and health games.

- **Playing area:** The playing area is 18 m long and 9 m wide. It should be free from obstruction up to a height of 7 m measure from the ground.
- **The net:** The net shall be 1 metre deep and at least 9.50 m long. The height of the net is measured in centimetres. That is 2.43 m for men and 2.24 m for women.
- **Position of players:** At the time the ball is served, players of both teams must be within their courts in two lines of three players, taking position as follows: Three players at the net are front line players occupying from right to left position 2,3 and 4. While the tree players in the back line occupy from right to left position 1, 6 and 5.
- **Rotational rule:** On change of service or when a team gains the right to serve the ball all the six players on court will move one playing position clockwise before serving.
- **Scoring and results of the game:** A game of volleyball consists of 3 or 5 sets.
- A set constitutes 25 points.

- For a team to be considered the winner of a match must have won at least 2 of the 3 sets or 3 of the 5 sets.
 - A set is won when a team has scored 25 points and has at least a 2 point lead over their opponents.
 - In case of a tie at 24/24, the set continues until one team has the lead of 2 points i.e. 24/26, 25/27, 26/28 etc.
 - **Interruptions of the game:** This is the period when the team makes an official request for stopping a player through the captain or team coach. The period is used by the coach to give the team advice. A team is allowed 2 (two) time out intervals per set. The length of which must not exceed thirty seconds. During time out, players of both teams are supposed to leave the court completely.
 - **Substitution:** Involves the changing standing players on court with those off court called substitutes. One player, two players or all the six players may be replaced at the same time in a given set.
 - A substitute player may be allowed to come back and play only if replacing the substitute who had replaced him/her.
 - A substitute player may come on play only once in a given set.
- Learners go and research on other rules governing the conduct of volleyball game.
- On interruption due to injury
 - intervals between sets
 - intervals of the match

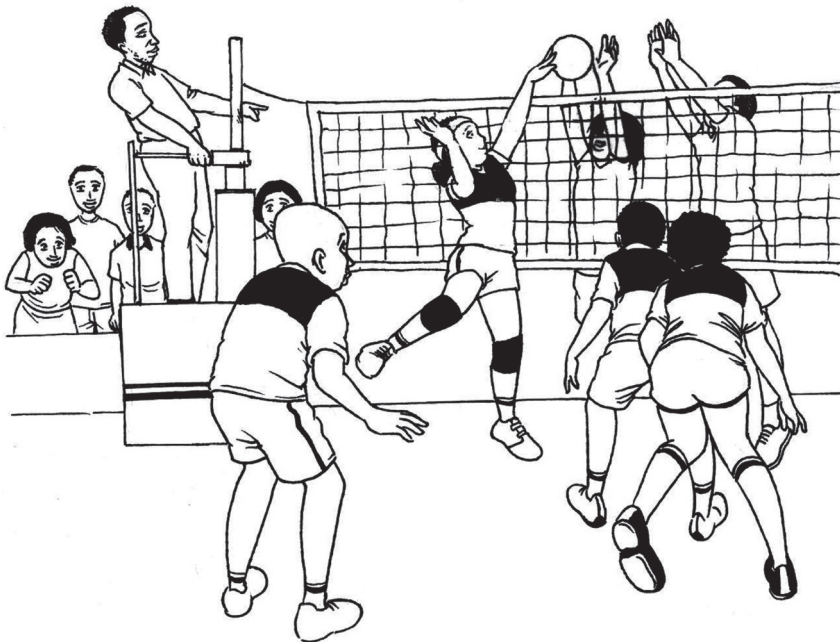

Learners playing volleyball while applying the rules of the game

Cool down:

- Guide learners to perform cool down exercises. They should walk around the volleyball court 2 times and then stretch their muscles systematically.

Final Discussion:

- Learners will discuss what they have learnt about attacking system in volleyball.
- Give the importance of attacking systems in volleyball.
- How are attacking systems helpful in our daily life?

End of Unit Assessment

- Setting exercise and evaluate how learners develop various skills of defence and attacking system.

Additional Notes

The body

Through brainstorming guide learners to generate points regarding benefits of volleyball playing to ones body. Promoting physical fitness of one's body. Exercises that are required to perform techniques and tactical skills make a player's muscles strong, relaxed and enduring to pain even turning becomes easy and fast. This is true basing on the fact that achieving the required skills and tactics involve training in passing, serving and blocking techniques. This gives room to increasing on chances of a person staying healthy. The heart and lungs will receive more oxygen hence improving on the transportation of blood to all the required parts of the body.

Help learners to know that regular training and involvement in volleyball games improves on hand -- eye coordination. For instance after serving, a player must follow the ball with his/her eyes. This helps in the process of striking the ball at the right moment. This is how players are enabled to react to where the ball is going. And this later influences quick thinking hence getting back to position to make the play.

Volleyball playing builds agility, coordination speed and balance. As the game is going on the player is expected to serve, pass, set, attack, block and dig the ball. Therefore, emphasise to the learners that these skills require flexibility, good judgement, balance of upper and lower body strength and speed so as to play effectively. Volleyball playing needs strong chest and muscles for nearly every game.

- Emphasising to the learners that once a person gets involved in physical activities like volleyball, he/she will be able to burn excess fat hence resulting in the making of internal body organs to work well These include organs like the heart and lungs.
- Strengthening the upper body, arms and shoulders as well as muscles of the lower body. Increases on cardiovascular and respiration systems, burning calories and fats leads to loss of weight hence maintaining wellness of an individual body.
- Let the heart and lungs be drawn in daily life
- Volleyball training promotes social interactions. Players of all walks of life get the chances to meet during training. As they meet, then are several chances to share and learn from each other.

- Let learners know that social interactions is very vital to development. The fact behind this could in favour of one's educational strength and promoting human rights. Playing volleyball increases on energy levels and improves one's overall performance of other sports and workouts. This is true that as one is training to perfect the skills other sports activities are equally done. Like block or smashing techniques involves jumping.
- Letting learners to know that volleyball playing boosts mood and increases drive to success. Improving ones mood once one gets involved in playing volleyball. And as a result reduces on stress levels that one is likely to get.
- Letting learners to give more benefits of volleyball playing like improving on self confidence, self esteem and making one feel generally happy.
- Guide learners to give reasons for playing volleyball for the society. Volleyball is a recreational game to many people from society. Serving as a recreation to the players, organiser and spectators. The techniques once skillfully appeared excites both players and people watching.

Players and people watching volleyball game for enjoyment. (both sex is involved.

- Let learners be able to explain how volleyball as a sport can promote economic development.
- Teach learners that for professional coaches, players and instruct earn once appointed by the interested group to give expatriate service.

Other people in the society may indirectly earn once competitions are held within their localities. This could possible through providing necessary services caused by the prevailing circumstances.

Many people get the opportunity to set, exhibit and market their products given the chance to access a big population. Demanding service vary from society to society. Some people may need edible while others essential commodities.

Unit Summary 6

In this unit I have taught learners on different skills of attacking and defending, interpreting rules of the game and discuss qualities of a good leader.

In the next unit, we shall learn about the different tactics of a basketball game.

Unit Glossary 6

Antennae: Equipment fixed on the volleyball net to indicate in the air where the ground sidelines stop.

Flip : An action of jumping up and completely turning over in the air.

Pivoting : To turn or balance on a central point.

Flex : To bend part of your body in order to stretch it to exercise.

UNIT 7: BASKETBALL

Content map for Unit 7

Item	Content
Key Unit Competence	Use different defensive and offensive basket ball techniques in various game situations and interpret the rules of the game.
List of lessons	4 - 1. Basketball techniques and tactics. 2. Systems of Basketball game. 3. Basketball rules and technical gestures. 4. Game situation
Introduction	In this unit we are going to learn ; - the different tactics used in a basketball game. - the importance of using systems and technical gestures in a basketball games. - the role of participating in teamwork and the qualities of a good leader. - the exercises of applying rules of the basketball game and promotion of fair play at the basketball court.
Classroom Organisation	Whole class orientation, individual practise, group work, pair work, playing in a team, free play.
Equipment required	<ul style="list-style-type: none"> - whistle - chasubles - cones - First aid kit - resource persons - stopwatch - balls - playground - relevant books - bibs
Activities	<ul style="list-style-type: none"> - Basketball tactics - Making a dummy - Passing drill - Passing with a step to the right - Passing with a step to the left - Position switching drill - Basketball systems - Free form attack drill - Counter attack drill - Man to man mirrors - Free play
Competences practised	- Communication, application, creativity, accept defeat, competitive spirit, appreciating success and leadership among others.
Language practice	<ul style="list-style-type: none"> - Brainstorming intervals. - Discussion session in pairs and groups.
Vocabulary acquisition	<ul style="list-style-type: none"> - persue - transition - switch - dummie - tactic - pivot
Numeracy	<ul style="list-style-type: none"> - Counting the points on every goal scored. - Counting steps. - Counting attempts to score.

Study skills	Receiving, passing, attacking, defending a team, leadership and cooperation among others.
Learning outcomes	Ability to apply various skills of attacking, defending and interpreting of rules in a basketball game situation.
Cross - cutting issues	<ul style="list-style-type: none"> - Gender: Engaging both boys and girls in practice. - Inclusive education: Adjusting activities to suit all learner's abilities. - Standardisation culture: Having all learners play on the same ground using the same equipment. - Genocide studies: Having learners work together in groups and promoting fair play during games by following rules. - Peace and values education. - Comprehensive sexuality education. - Financial education. - Environment and sustainability
Assessment criteria	Setting exercises and evaluation of how learners use basketball different systems and interpret rules in a game situation.

Key unit competence:

Learners will be able to use different defensive and offensive basketball techniques in various game situations and interpret the rules of the game.

Learning objectives:

Knowledge and understanding

- Demonstrating different tactics used in a basketball game.
- Discuss the importance of using systems and technical gestures in a basketball game.
- To recall the role of participating in teamwork.
- State different qualities of a good leader.

Skills to be developed

- receiving
- attacking
- leadership
- force
- passing
- defending
- cooperation

Attitudes and values

- fair play
- competitive spirit
- appreciate the success
- accept defeat
- learn from mistake
- leadership

Content :

- Exercises of different basketball tactics in game situations.
- Exercises of applying systems of the game.
- Exercises of applying rules of the game and promotion of fair play.

Lesson 1: Basketball techniques and tactics

Lesson objectives:

Learners should be able to demonstrate various techniques and tactics used in a basketball game.

Teaching Methods:

- Explanation
- Practical
- Pair work
- Brainstorming
- Group work

Teaching and Learning Materials

- Whistles
- First Aid kits
- Balls
- Experts

Lesson development

Introduction

- Call the learners into a circle or into designated lines and greet them.
- Ask the learners for volunteer to lead others into a warm-up.
- Let him/ her select exercises to use in this warm up session. They may include; jogging, sprinting, skipping, pushups, and sit ups among others.
- Guide them appropriately for effective warm up.



Learners performing warm up exercises

Lesson body

- Step 1:
- Explain in about 20-30 seconds what you will be practising today (Basketball tactics)
 - Tell them to name any basketball tactics they know.

Activity: 1 Basketball tactics

- Have learners stand in their own space around the playing area.
- Instruct them to explore their basketball tactics according to their own understanding.
- Move around the playing area and make observations.
- You may note them down.

Step 2 : Signal to call learners back into the circle.

- Explain and demonstrate basketball tactics.
- Mention that a tactic simply means to do something in a planned way
- State the examples of tactics we have in basketball. These include:
 - Dummies
 - Breaking free
 - Pass and pursue
 - Pivot
 - Pass and move
 - Switching.

Step 3 : Introduce the dummies tactic.

- Explain that the dummies simply mean to pretend to go or pass the ball in a certain direction but instead go or pass in another direction.
- Give them an example;
- If Ineza is looking in the East and quickly faces the West as she is passing the ball, she has performed a dummy.

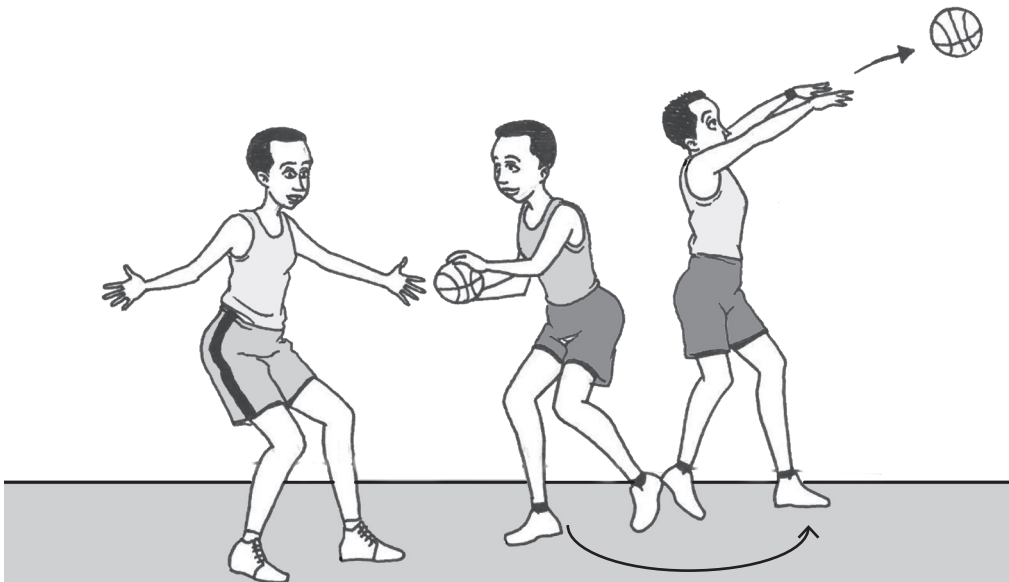

A dummy being made

Activity: 2 Making a dummy

- Ask learners to stand in groups of three making a triangle.
- Explain that in each group;
 - One player is the defender
 - Two players are attackers.
- When you blow the whistle, one of the attackers will dummy to pass the ball to the receiver (teammate). He/she also do the same to return the pass.
- Move around playing area to make observations and ensure good passing technique.
- You may switch player roles after sometime.
- Encourage continuous practice.

Step 4 : Introduce pivoting:

- Explain that is where you rotate on the toes of one foot to change direction of play.
- Tell them the difference between front pivot (rotating in a forward direction) and reverse pivot (rotating a backward direction)
- Emphasise that pivoting should be done on the foot you land on.
- If you land on both feet, the decide which one to pivot on.

Teaching points

- Slightly bending on the knees.
- Evenly distribute body weight between both legs.
- Rotate on the foot you landed on using the ball of the foot.

Activity: 3 Passing drill

- Have learners form groups of five.
- Give each group a ball.
- Ask each group to form a circle.
- Encourage enough passing space between players of each circle.
- Explain and demonstrate that on signal;
 - The player with a ball will rotate forward (front pivot) and pass the ball to the neighbour.
 - The neighbour will also do the same until everyone gets a turn.
 - Instruct player to make a reverse pivot (rotate backwards
 - Encourage continuous practice for certain amount of time.
- Move around the playing ground as you tell learners to;
 - Increase the speed of the game.
 - Avoid dropping the ball.
 - Use a variety of basketball passes.

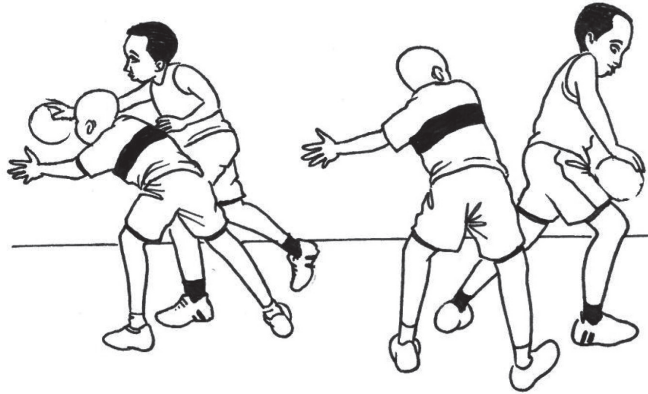

Front pivot and reverse pivot

Step 5 : Have the learners practise “pass and move”

- Mention that pass and move is where you pass the ball to teammate and quickly run into free space to receive a return pass.
- You can either decide to shoot or pass again.

Activity: 4 Passing with a step to the right

- Have learners pair up.
- They should stand facing each other.
- One makes a pass to the other and quickly takes a step on the right.
- The other will receive the ball and quickly pass it as he/she makes a step in the same direction.

Activity: 5 Passing with a step to the left

- Then repeat.
- Encourage continuous practice.
- When they reach the other end, they can come back passing and moving to the opposite side.
- Make it clear that the ball should not fall down.
- Invite learners to use different types of passes.

Step 6: Introduce pass and pursue

- Explain that this done normally when passing to an opponent.
- He/she attempts to run after the opponent in order to steal the ball away.
- Mention that this is a great technique to maintain a team's possession of the ball.
- If a teammate make a mistake, he/she should try to correct it immediately.
- Tell the learners that switching is also another great tactic.
- State that it simply means exchanging of places with teammates.

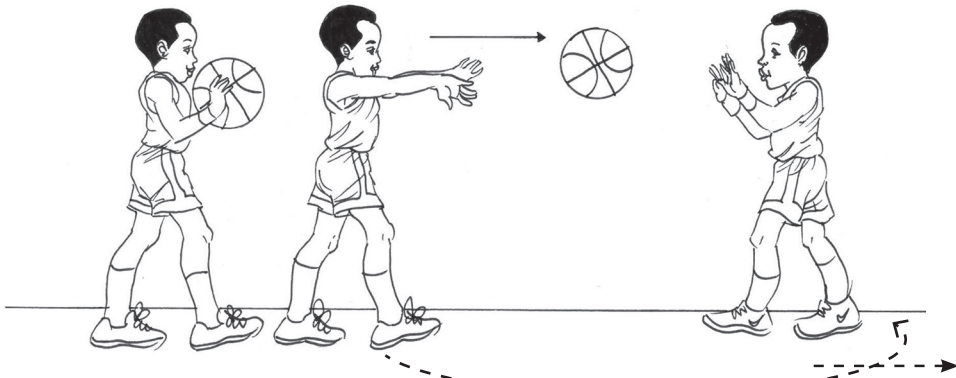

Pass and pursue

Activity: 6 Position switching drill

- Demonstrate switching and have learners to do the following;
- Pair up in 1 and 2, 3 and 4, 5 and 6, 7 and 8 as in the picture above.
- Explain and demonstrate that 1 and 2 will start with the ball.
- On signal, both pass the ball to their neighbours on the right, then quickly run and exchange places.
- At this point, 7 and 8 have the ball, they do the same.
- And the game continues in the same way.

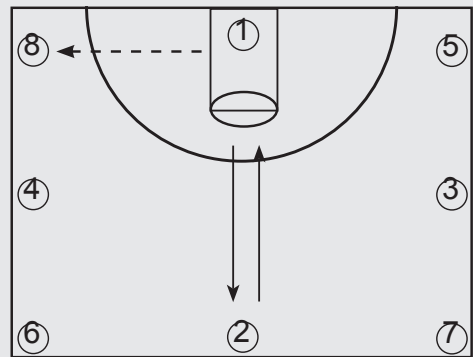

Move around the playing area and continually remind players to:

- Make accurate passes
- Switch places as quick as possible without sabotaging accuracy.
- Step towards the ball to catch it.
- Avoid dropping the ball.

Safety: -Let them keep their heads up and eyes looking forward to avoid bumping into each other when switching.

- Have them try not to touch other players.

Cool down

Guide the learners to perform cool down exercises. Let them jog around the activity area stretch and finally strengthen their muscles.

Conclusion

Ask the learners to help you collect all the equipment you were using in the lesson.
Signal learners to come around and stand in a circle.
Conduct a feedback about the lesson.

Final discussion

Let them review the lesson by asking them related questions.

- a. Who can name any basketball tactic?
- b. Describe how it is done.

What are the importance of baset ball techniques and tactics in our daily life.
Why are basket ball rules and technical gestures useful during the game situation.
How are defensive and offensive basketball techniques helpful in our daily life?

Lesson 2 : Systems of Basketball game

Lesson objectives:

Learners should be able to perform various systems in a basketball game.

Teaching methods

- | | |
|----------------------|------------------------|
| - Explanation | - Practical |
| - Brainstorming | - Demonstration |
| - Direct instruction | - Observation |
| - Pair work | - Class discussion |
| - Group work | - Question and answer. |

Teaching and learning materials:

- | | |
|------------------|--------------------|
| - Balls | - stopwatches |
| - Cones | - whistle |
| - Jerseys(bibs) | - Relevant books |
| - Chasubles | - Resource persons |
| - First aid kit. | |

Lesson development

Introduction

Ensure a safe learning environment: it should be clean, ventilated and spacious.

- Ask the learners to pick out debris from playing area is any.
- Have learners warm up is in about 3 - 5 minutes including;
- Jogging around playing area.
 - Skipping a rope.
 - Stretching exercises like side bend.
 - Stretching exercises like pushups.

Lesson body

Step 1 : Hold a class discussion for about 7-10 minutes

- Ask the learners questions about basketball tactics.
- Give all the learners a chance to respond to at least one question.
- Articulate brilliant ideas for the sake of learning.
- Provide feedback to guide learners appropriately.

Step 2 :- Introduce this lesson; system of basketball.

- Ask the learners guiding questions about system of basketball game questions could include;
 - What is the meaning of the word system?
 - How many systems can be applied in basketball game?
 - Can you name them?
 - Explain how each of them can be applied.
 - What do you think is a defensive system? How can it be applied in basketball game?
 - Who can tell me about what an attacking system means?
 - Listen carefully to learner's ideas and write them down.

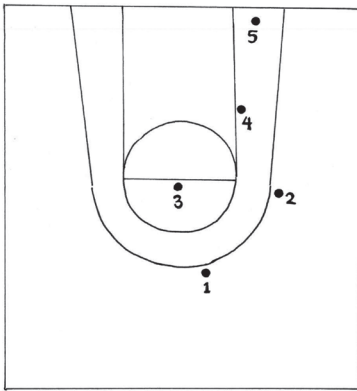

Basketball attacking systems

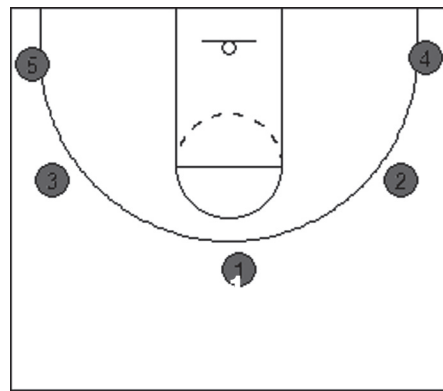

Free form attack

Activity : 1 Basketball systems

Forming teams.

- Give the learners balls to play basketball systems according to the systems shown.
- Provide feedback.

Step 2 : Explain the attacking system in basketball.

- The major aim of an attacking system is to increase a team's scoring opportunities.

- Explain that this can be achieved by creating highest number of situations where opponents are outnumbered and disorganised.

Step 3 :- There are so many types of attacking systems. They include:

- Free form attack
- Zone attack
- Counter-attack

Free form attack.

- It basically consists of a motion and passing a game.
- It requires the all players to have mastered any position on the floor.
- The players make decisions of who shoots, who dribbles and dribbles penetrates through defence during the game. This means the coach has little control over what happens on the floor.
- To practise free form attack, have players understand why they are doing things not just having to do them. This will ensure they make better decisions during the game.

For example:

A cut on the second pass might create a lay up on the fourth pass. Without this big picture, players may never get to the fourth pass.

- They must understand that being open enough reason to shoot the ball if there is a better shooter open for the next pass.
- Emphasise the key free to form an attack:
 - Players understanding their own roles on the team.
 - Players understanding the role of their teammates.
 - Embracing the roles and playing towards their strengths.
- Have learners practise free form attack.

Activity : 2 Free form attack drill

- Divide learners into 2 teams.
- Ask each team to decide who the passer, shooters and the penetrators will be according to what they think their strength are.
- Mention that on the signal, they will play a normal basketball game using their own decision of who passes who shoots and who penetrates defence.
- Move around the play area and note observations.
- Guide them appropriately.
- Emphasize that;
 - Players know their own roles.
 - Players understand their teammates.
 - Embrace roles and play towards their strength.

Step 4 : Introduce zone attack:

- Explain that this simply means attacking specific areas (zones) at the court (floor).
- Demonstrate zone attack
- As the ball moves, the players try to slide into “dead spots”(unguarded areas) in the zone. Therefore, each time the ball moves, the zone has to adjust and those “dead spots” change as well.

Make it a role of the players is to search for those dead spots to attack opponents.

Step 5 : Introduce counter-attack:

- Mention that the counter-attack is an attack made immediately after an attack.
- It is explosive in nature and shortest of attack.
- It starts with quick recovery of the ball from blocked shot, pass or rebound.
- It ends with clear shoot at the opponents goal or simply transition into opponents front court.
- Explain the reasons for counter-attack. They include;
- Helps attacking players to move fast.
- Increases a team’s scoring opportunity.

Step 6 : Demonstrate counter-attack:

- Show learners in slow motion and first and then increase speed.
- Select two volunteers to help you demonstrate, they should be good at passing and shooting.
- Strategically position them forward towards the goal.
- Start with the ball and quickly pass to one who passes to two who immediately takes the shot.
- Mention that the above needs to be done as quickly as possible in order to take advantage of fewer defensive players to score goals
- Explain to learners that the ball in flight move faster than the player.
- The deeper the first pass, the greater the scoring opportunity because attack is against fewer defenders.
- The shorter the first pass, the longer the ball takes to get to the goal and the more attackers face a tougher defence.

Activity: 3 Counter attack drill

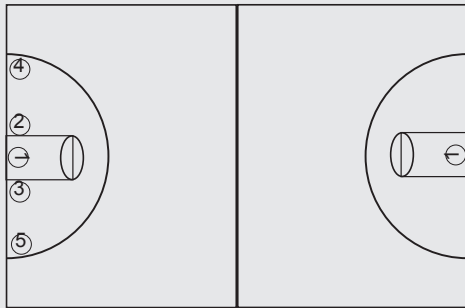

- Let learners stand on one side of the court.
- Explain and demonstrate that when you blow the whistle:
 - Player number one will pass the ball to player number 2.
 - Then player one will run very fast to follow the direction of his/her pass and stand behind player number four.
- Player number two will now pass to player number three, then also follow the direction of his/her pass.
- The movement continues until the end of the game.

Progressions

Encouraging players to advance the ball down the court until they make a lay up. Then continue doing the same as they move in the opposite direction.

Step 7 : Talk about defensive systems in basketball

- Mention that there are so many types of defensive systems. They include:
 - Man to man defence.
 - Zone defence.
 - Match up zone defence

The main aim of defensive systems is to stop opponents from scoring.

- Explain and demonstrate man to man defensive system.



Players marking each other man to man.

- Man to man simply means that each player on the team is given a specific offensive player to mark or guard during the game.

The key to win man to man is to:

- Follow your man's movements throughout the game.
- Attempt to block your man's passes or shot and try to steal the ball.
- Explain that it is important to react to the ball, the only man who can score is the one having the ball.

Therefore if he is open, go guard him and if he passes back to your man, sprint back to guard your man.

- Give learners a chance to practise man to man in a game situation.

Activity : 4 Man to man mirrors

Man to man Mirrors

This activity will require players to mimic their partner's movements in order to develop quick reactions while working on defensive footwork for man to man.

Tell learners to find a partner and stand in pairs behind the baseline marked with cones.

If you have another teacher, it's best to use both ends of the court to maximise practice.

Explaining and demonstrating how to play:

- Find two parallel lines on the court
- The first pair comes out and sets themselves up directly opposite each other on the two parallel lines on the court.
- The teacher then assigns one of them the offensive player and the game begins immediately.
- The goal of the defensive player is to stay directly in line with the offensive player.
- The offensive player must work hard to try and separate themselves from being in line with the defender by sliding up and down the line of the court.
- After 15 seconds, the teacher calls out 'switch' and the two players swap roles.
- After 30 seconds they step behind the baseline and two new players come in.



Man to man mirrors

Teaching Points:

- Players must stay in a low defensive stance with their hands out wide the entire time of the drill.
- Encouraging the offensive player to use head fakes and quick changes of pace to throw the defender off.
- Making sure you cover what good defensive stance is before running this activity.

Step 8 : Explain and demonstrate zone defensive system.

Mention that guard zone defence is the opposite of man to man, instead of guarding a specific man, Players guard a specific zone on the court.

Movement in the zone defensive systems depends on where the offensive players are standing and where the ball is.

- Explain to the learners that zone defensive system is a good way to stop inside scoring, because multiple players can easily surround (defend) a player trying to get the ball inside.
- Mentioning that an example of zone defensive systems is 2 3 zone defence. It consists of two players at the front and three players behind (closer to the basket)

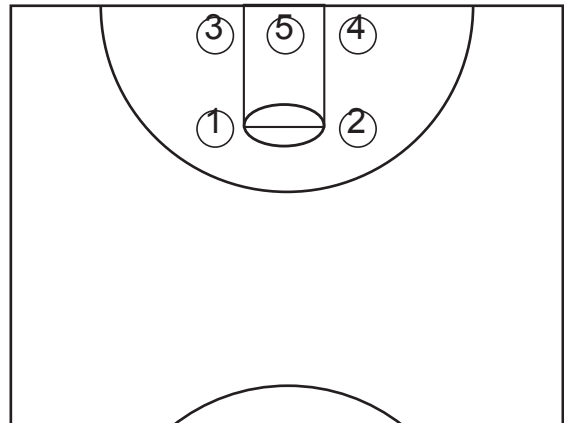

2 - 3 zone defence system

- Explaining how 2 - 3 zone defence works:
 - If an opponent runs to the right or left wing beyond the three point arc, defensive players 1 and 2 should shift towards that direction and guard the ball.
 - If an opponent moves to the right corner within the three point arc, player 4 and the rest of the defenders should shift towards that direction to guard the ball. No defensive player will be expected on the left side in such a scenario.
- Emphasising that communication is very important, encourage players to talk to each other of who is open, who should be where, what to do ... among others.

Step 9 : Explain and demonstrate match-up zone defensive system. Mention that it combines principle of both man to man and zone defensive systems.

Match-up the zone will require players to:

- Take the shape alignment.
- Communicate to teammates, who is open and what to do among others.
- Keep inside players guarding on the inside and perimeter players on the outside.
- Stick to the offensive player's movements and make switch screens or exchange where necessary.
- Block the shot and rebounding the ball without falling.
- Giving learners an example of a match up combination, box and one.

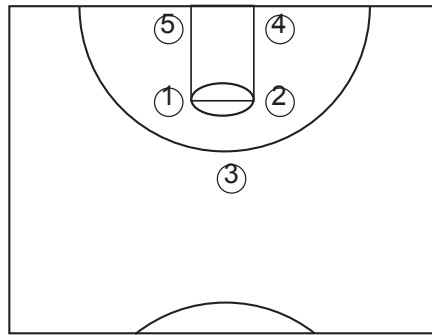

Match - up zone defensive system

- In this defence, four players play zone (in a box shape) and one player (3) plays man - to - man - usually marking the best offensive player.
- Tell learners that the on - ball defender should play tight as if she/he was playing man - to - man. The zone (box) away from the ball will stay on guard to defend the ball just in case man - to - man fails.

Note:

When setting match up zone defensive., ensure that the big me/women stay low in the post as the guards stay around the perimeter.

Cool down

Guide the learners to perform cool down exercises. Let them jog around the activity area stretch and finally strengthen their muscles.

Conclusion

Ask the learners to help you collect all the equipment you were using in the lesson.

Signal learners to come around and stand in a circle.

Conduct a feedback about the lesson.

Final discussion

Let them review the lesson by asking them related questions.

What are the importance of basketball systems in our daily life.

Why are basket ball systems useful during the game situation.

How are basketball systems helpful in our daily life?

Lesson 3: Basketball rules and technical gestures

Lesson objectives:

By the end of the lesson learners should be able to identify rules and perform various technical gestures used in a basketball game.

Teaching methods:

- Introduction
- Demonstration
- Practical
- Question and answer
- Observation
- Classroom discussion.

Teaching and learning materials.

- Relevant books
- Knowledge
- Basket
- Cones
- stopwatch
- Balls
- Rims
- First aid kit.

Lesson development:

Introduction

Have learners come around into a circle or designated lines and greet them.

- In about one minute, briefly explain what you are going to teach (Today we are going to learn the rules and technical gestures in basketball)
- Modulate a class discussion, ask them related questions for example:
- Mention any rules that you know in basketball.
- Tell me at least one technical gesture used in basketball.
- You may write down their answers and ideas on board or piece of paper.
- Guide them to perform warm-up exercises. Let them stretch and strengthen their muscles systematically.

Activity: 1 Free play

- Tell the learners to formulate their own rules.
- Have learners be divided into two teams.
- Ask the them to play a normal basketball game following their own rules.
- Tell them to select a referee.

Lesson body

Step 1 : Explain and demonstrate where necessary basketball rules. Basketball rules include the following:

- Basketball is a team sport played by two teams of five players.
- The aim is to score points and prevent the other team from scoring.
- Teams score points by throwing the ball into the basket or goal. (shooting).

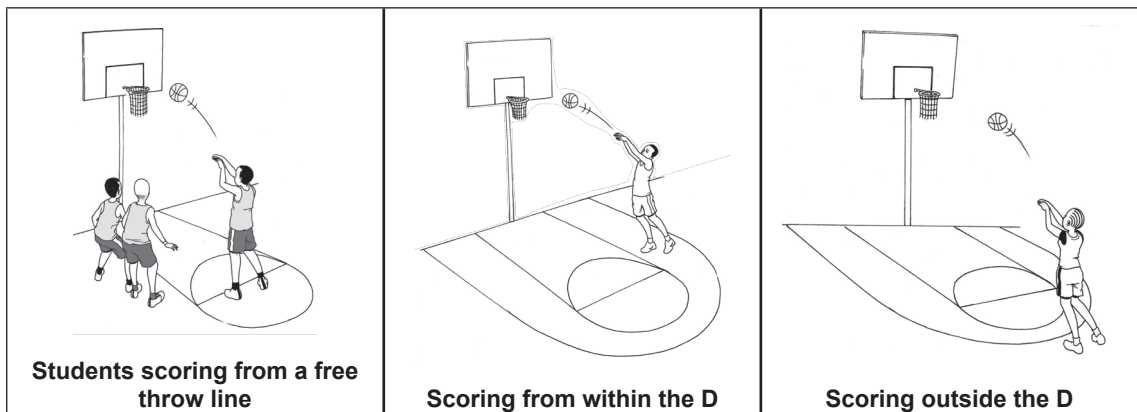

One point is awarded





Two points are awarded









three points are awarded.

- Each team is assigned a goal to defend,
- They score in the other team’s goal.
- At half time, teams switch goals.
- The game begins with a tip off.
- The ball can be moved in any direction on the court by either passing or dribbling.
- A player is not allowed to walk with the ball. It is called **travelling**. He/she should pivot to change direction.
- A player cannot dribble again after the first dribble ends or dribble the ball using two hands at the same time. That is called **double dribble**.
- Explain that dribbling should be done with one hand and either pass or shoot when it ends.
- A player is out of bounds if any part of his/her body touches the floor.
- A ball is considered to be out of player if it crosses the court’s end lines.
- The team that touched the ball last losses the ball to the other team.

Step 2 : Introducing technical gestures in Basketball.

- Explain that these are hand signals used by referees to communicate to players, table officials and spectators.
- Demonstrate technical gestures and have learners mirror your actions as they learn them.
- Remember to introduce them one by one to avoid confusion.

Technical gesture	Demonstration (Communication)
	<p>Stopclock</p> <p>Raise one hand straight over your head with the palms facing out and fingertips pointed signals the timekeeper to stop the clock.</p>
	<p>Start clock</p> <p>Drop your raised hand directly towards the floor to indicate start clock.</p>
	<p>Full timeout</p> <p>When you spread two arms to both sides forming a “T” shape, it indicates full timeout.</p>
	<p>Blocking</p> <p>Put both hands, in fists, touching your hips, with elbows in tight against the body to indicate that a defensive player has committed a blocking foul.</p>
	<p>Holding</p> <p>Show holding by having one arm extended upwards in front of the face, and the other hand grabbing the wrist.</p>

	<p>Pushing</p> <p>Have both hands extended straight in front of you, with the palms facing outward to show a pushing foul.</p>
	<p>Double Foul</p> <p>If two players foul an opponent at the same time, show this by putting both hands, in fists, extended out towards the sides.</p>
	<p>Intentional Foul</p> <p>If a player commits an intentional foul, show this by putting both arms above the head and cross them.</p>
	<p>Double Dribble</p> <p>Have both of hands in front of you, with palms down, and alternating them up and down, as if dribbling a basketball to indicate double dribble.</p>
	<p>Travelling</p> <p>Signals travelling by placing both of his hands in front of you and moving them in a circle.</p>
	<p>Carrying or Palming</p> <p>Signal carrying by putting one hand at the side, flipped over from palm up to palm down.</p>
	<p>Kicking the Ball</p> <p>Have one foot raised in front of you to indicate that a player has kicked the ball</p>
 <p>Point(s) scored use 1 or 2 fingers after signal 14</p>	<p>Two points</p> <p>Extend one arm parallel to the floor and pointing with two fingers to show that two points have been scored</p>
 <p>Attempt and if successful</p>	<p>Three points</p> <p>Extend both arms directly upwards with fingers pointed to show that three points have been scored</p>

	<p>Basket not counting</p> <p>Extend hands out directly towards the side to show that the basket does not count</p>
---	---

Cool down

Guide the learners to perform cool down exercises. They should jog around the activity area stretch and finally strengthen their muscles.

Conclusion

Ask the learners to help you collect all the equipment you were using in the lesson.

Signal learners to come around and stand in a circle.

Conduct a feedback about the lesson.

Final discussion

Let them review the lesson by asking them related questions.

What are the importance of basketball rules and technical gestures.

Why are basketball rules and technical gestures useful during the game situation.

How are basketball rules and technical gestures helpful in our daily life?

Lesson 4: Game situation

Lesson objectives

By the end of the lesson learners should be able to play with others and apply rules to promote fair play.

Teaching methods:

- Introduction
- Brainstorming
- Class discussion
- Explanation

Teaching and learning materials.

- Knowledgeable persons
- Relevant books
- Stopwatches
- Pens and papers.

Lesson development:

Introduction

- Guide the learners to perform warm-up exercises. Let them stretch and strengthen their muscles systematically.
- Briefly review the basketball rules and techniques.

Lesson body

Step 1 :- Game situation.

- Divide the class in groups of 5.

- Use half court for two teams and another for two teams.
- Let other teams wait outside for 5 minutes as they cheer up those on court.
- Supervise focusing on how leadership and teamwork are being put into practice.
- Correct the errors and encourage the learners on court.
- Switch after 5 minutes so that those who have been outside the court get a chance also.
- Continue switching teams until time is over..

Cool down

- Guide learners to perform cool down exercises. Let them walk around the basketball court two times and then stretch their muscles.

Conclusion

- Ask the learners to help you collect all the equipment you were using in the lesson.
- Signal them to come around and stand in a circle.
- Conduct feedback about the lesson with them.

Final Discussion

Let the learners discuss the advantages of the following:

- | | |
|--|------------------------|
| - Cooperation when playing basketball. | - Fair play |
| - Patience | - Sportsmanship |
| - Teamwork | - Team spirit |
| - Accepting defeat | - Appreciating success |
| - Courage | - Competitive spirit |

End of Unit assessment

Let the learners use defensive and offensive techniques during the game situation following the rules

Unit Summary 7

In this unit we have learnt various exercises used in attacking systems, exercises of defensive techniques, leadership and teamwork, technical gestures and application of rules in the game situation.

In the next unit, we shall be learning the attacking systems, exercises of applying different handball tactics and systems and exercises of interpretation of handball rules during the game.

Unit Glossary 7

- Pursue** : To follow someone in attack.
- Dummy** : Pretend to pass the ball to a player and then you do not.
- Switch** : To change roles with another person.
- Tactic** : A plan used with an aim of gaining an advantage over the opponent.
- Transition** : To change from defence to attack or attack to defend.
- Pivot** : To rotate on one foot.

UNIT 8: HANDBALL

Content map for Unit 8

Item	Content
Key Unit Competence	Use different defensive and offensive handball techniques in various game situations and interpret the rules of the game.
List of lessons	4 - 1. Techniques of attack 2. Techniques of counterattack 3. Defensive systems 4. Handball rules
Introduction	Handball as a game playing progress from basic skills. And later upgrades to the secondary skills. In this unit we shall focus more or both attacking and defensive skills.
Classroom Organisation	Whole class orientation, individual practise, pair work, group work and free play on the Handball court.
Equipment required	Balls, stopwatches, goalposts, whistle, chasuble, playground, net, cone, tree etc.
Activities	<ul style="list-style-type: none"> - Exercises on attacking in handball tactics and techniques i.e pivot play and fast break. - Performing exercises on individual defer man to man defence (6-0), (5-1), (4-2), (3 -2-1).
Competences Practised	<ul style="list-style-type: none"> - Stating different system used in handball. - Identifying handball rules from other sports. - Recalling the role of leaders in teamwork
Language practice	<ul style="list-style-type: none"> - Attacking. - fast break. - Pivot play.
Vocabulary acquisition	Reverse shot, blocking, marking.
Numeracy	<ul style="list-style-type: none"> - Measuring the length and width of the handball court. - Counting points and goals scored.
Study skills	<ul style="list-style-type: none"> - receiving - passing - attack - defending a team - leadership - cooperation - force
Learning outcomes	Demonstrating techniques and tactics in handball organised attack system. Peace and values education
Cross - cutting issues	<ul style="list-style-type: none"> - Gender: Engaging both boys and girls in all activities. - Inclusive education: Adjusting activities by appropriately to suit learner's abilities.
Assessment criteria	Setting exercises and evaluate how learners use attacking and defending skills and interpret rules in the game situation.

Key unit competence:

Learners will be able to use different defensive and offensive handball techniques in various game situation and interpret rules of the game.

Learning objectives:

Knowledge and understanding

- State different systems used in handball.
- identify handball rules from other sports.
- Recall the role of leaders in teamwork.

Skills to be developed

- Receiving
- Defending
- Cooperation
- Passing
- Team leadership
- Force.

Attitudes and values:

- Appreciate the success.
- Accept defeat.
- Learn from ones mistake.
- Cooperation in teamwork.
- Competitive spirit.
- Leadership.

Lesson 1: Techniques of attack

Lesson objectives

By the end of the lesson, learners should be able to perform different techniques of attack.

Teaching methods:

- Demonstration
- Instruction
- Explanation
- Discovery
- Practice

Teaching and learning materials

- Playground
- Nets
- Cones
- Whistle
- Balls
- Chasuble
- Stopwatch

Lesson development

Introduction

Guide the learners to perform warm-up exercises. They should jog around, stretch and strengthen their muscles systematically.

Lesson body

- Step 1:
- Let the learners brainstorm on the techniques they know used in handball.
 - Guide them to tell the correct techniques.
 - Demonstrate the correct techniques.

Step 2: Game situation

- Divide the class into small groups of 5
- Using cones and handball goals create small fields in the playground.
- Let them play 5 Vs 5.
- The techniques will include: passing, receiving and shooting.
- Supervise the learners by giving them corrections and encouragement.

Cool down

Let the learners walk around the activity area, stretch and finally strengthen their muscles.

Conclusion

- Ask the learners to help you collect the equipment you were using during the lesson.
- signal the learners to come around and stand in a circle,
- Conduct the feedback about the lesson with the learners.

Final discussion

- How useful are the techniques of handball to the learners?
- What values do we gain from these techniques in our daily life?

Lesson 2: Techniques of counter attack

Lesson objective

By the end of the lesson, learners should be able to perform techniques of counter-attack.

Teaching methods:

- Explanation
- Practical
- Perform
- Instruction

Teaching and learning materials

- Playground
- Nets
- Cones
- Whistle
- Goals
- Other relevant equipment
- Balls
- Chasuble
- Stopwatch
- Chasubles
- Trees

Lesson development

Introduction

- Let learners brainstorm on what had been taught on counter-attack.
Describing counter-attack.
- Outlining the characteristics of the counter-attack.
- Suggesting the advantages of the counter-attack.
- Emphasising to the learners that with fast Break the winger starts with the ball.

- And passes it to the centerback.
- At this point the wing back and the winger make a forward run.
- Therefore the wing back reads the situation and later decides the best way to progress the attack.
- The purpose of the attack is to bring one or more players into such a position to shoot a goal.
- Identify one learner and task him/her to lead the rest into a five minutes warm up. Warm up include:
 - running here and there.
 - stretching and strengthening their muscles.

Lesson body

- Step 1:
- Explaining to the learners that defending (opponent) team aims at trying to take the ball away from the players (attackers) during passing or shooting.
 - Emphasising to the learners that defending can be done by:

- marking the opponent or zone.
- Trying to block the pass/sho

Further explain to the learners that blocking/marking can either be in man to man or zonal defence formation

Marking/block of man to man

Guiding learners to know that the team may decide that each member marks the opponent irrespective of whether the opponent has a ball.

The attacker is continuously blocked and prevented from making effective attacks

Teaching points on single block

- Keeping eyes on the ball.
- Standing firm with feet shoulder wide apart.
- Keeping the hands stretched in the air and fingers spread out.
- The hands should be kept in the direction and the incoming ball so that you block it.
- Blocking players must move with the attacker who has the ball.

Teaching points on group blocking

Emphasis to learners that this is done in group.

- Players form a human wall by staying close to each other.
- All movements towards, backward and sideways are done together.

Zonal Defence

Here each defender is held responsible for protecting a given playing area against the attacking team. It requires players to move and play as a team. i.e. blocking around the goal are done as a teamwork action.

Follow some of the defensive formations when a team of six players is used.

- 6 - 0
- 5 - 1
- 4 - 2
- 3 - 3 formation.

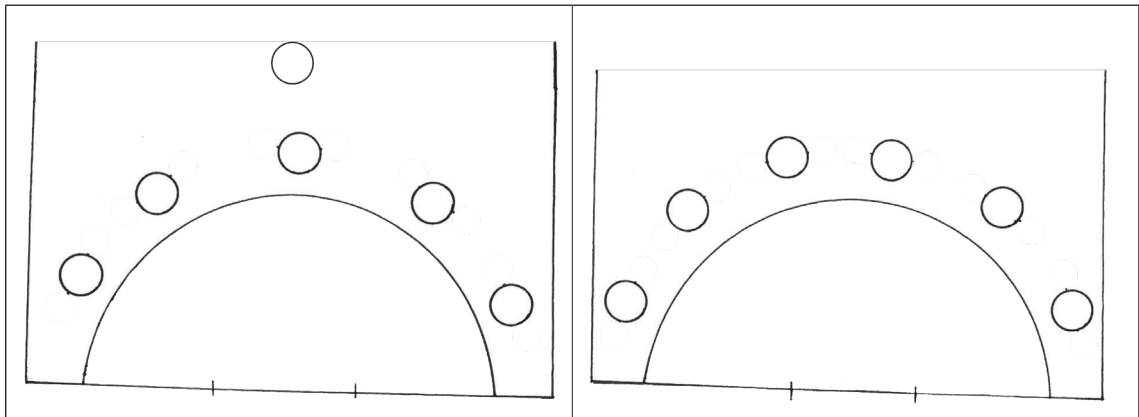

Defensive formation 5 - 1

Defensive formation 6 - 0

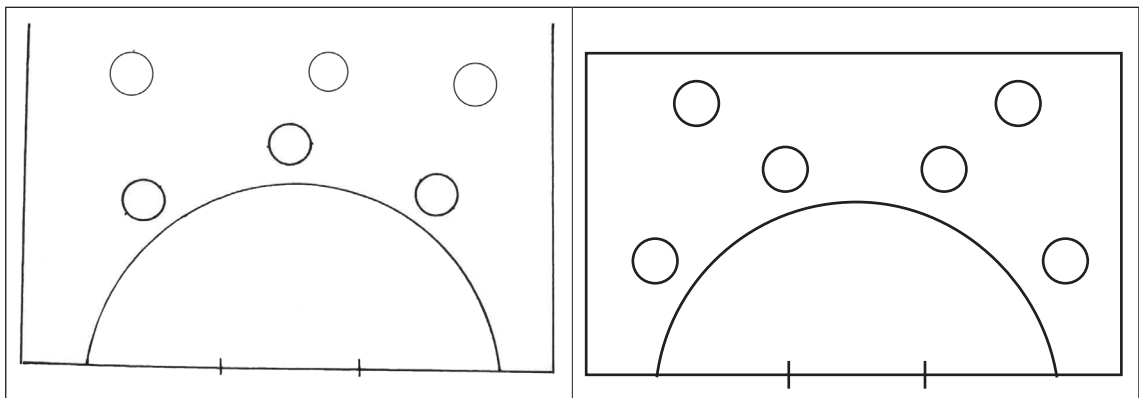

Defensive formation 3 - 3

Defensive formation 4 - 2

- Step 2 : Have learners brainstorming ideas about attacking systems. Giving them a chance to explain and demonstrate what they know about attacking systems.
- Step 3 : Explaining to learners that shooting is a basic attacking skill in the game of Handball. Emphasising to the learners that shooting is aimed at scoring. And if possible win the game.
- Tell learners that there are many forms of shooting. However, this time they are going to concentrate on reserve shoot .

Teaching points of Reverse shot

- Guide learners on the various steps to be considered where demonstrating reverse shot.
- Players face the opposite direction from the goal mouth, takes body to strong shooting side. Turn and quickly pivot to the opposite (weakside). Bend the knee and release the ball in aside arm action.

The body weight and momentum is directed towards the goal.

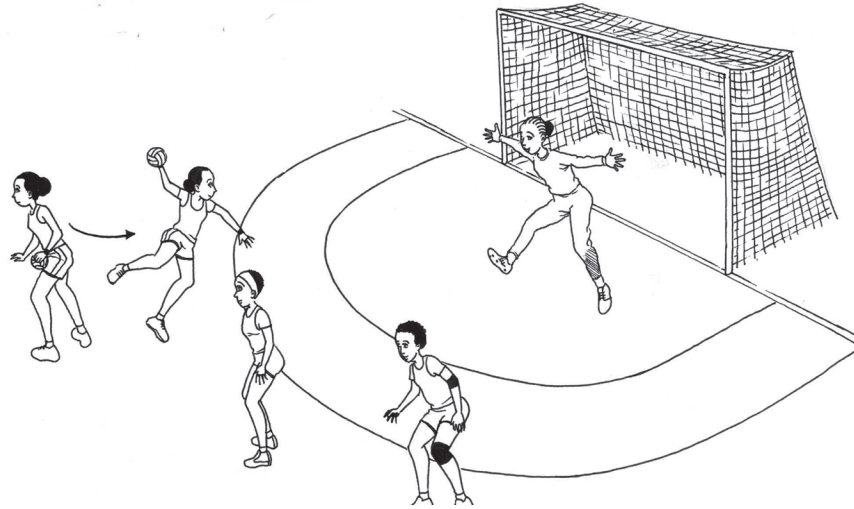

Reverse shot

Activity 1: Counter-attack

Let learners exercise on

- Individual defensive (man to man defence)
- Zone (6-0), (5-1), (4-2), (3-2-1).

Assessment

Setting exercise and evaluate how learners use attacking skills and defending skills and interpret rules in the game situation.

Final Discussion

Learners discuss what they have learnt about attacking systems.

Lesson 3: Defensive systems

Lesson objectives

By the end of the lesson, learners should be able to perform handball defensive systems.

Teaching Methods:

- | | |
|---------------|-----------------|
| - Explanation | - Demonstration |
| - Discussion | - Instruction |

Teaching and Learning Materials

- | | |
|--------------|-------------|
| - Playground | - Balls |
| - Chasuble | |
| - Cones | - Stopwatch |
| - Whistles | - Chasubles |
| - Goals | - Tree |

Lesson development

Introduction

- Guide the learners to perform warm-up exercises. Let them stretch and strengthen their muscles systematically.
- Let them brainstorm on the defensive systems they know about handball.

Lesson body

- Divide the class into small groups of 5.
- Using cones and handball goals create small fields in the playground.
- Let them play 5 Vs 5.
- Demonstrate with the learners the defensive systems.
- These include:
 - individual defence,
 - person to person defence,
 - zone defence; 6 - 0, 5 -1, 4 - 2, 3- 2 - 1
- Let the learners play on the various organised courts implementing the defensive systems.
- Supervise the learners by giving them corrections and encouragement.

Cool down

- Let the learners walk around the playground, stretch and finally strengthen their muscles.

Conclusion

- Ask the learners to help you collect the equipment you were using during the lesson.
- signal the learners to come around and stand in a circle,
- Conduct the feedback about the lesson with the learners.

Final discussion

- How useful are defensive systems of handball to a player?
- What values do we get from these systems in our daily life?

Lesson 4: Handball rules

Lesson objectives

By the end of the lesson, learners should be able to interpret handball rules in the game situation.

Teaching methods

- Discussion
- Explanation
- Demonstration
- Instruction
- Practice

Teaching materials:

- Playground
- Balls

- Whistles
- Chasubles
- Other necessary equipment
- Cones
- Tree

Lesson development:

Introduction

Guide learners into Warm-up exercises of jogging, star jumps and sit-ups. Pix of the below:

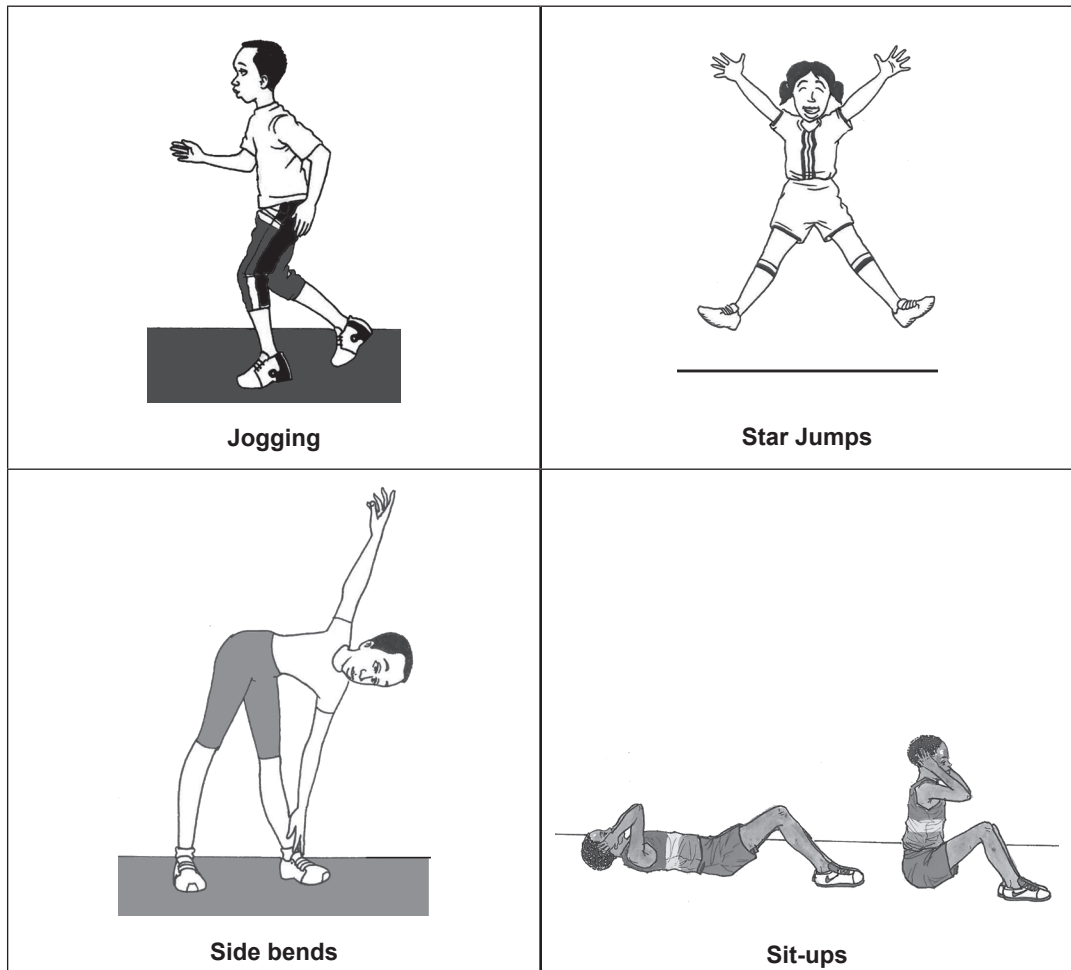

Lesson body

- Step 1
- Provoke learners through brainstorming to mention some of the rules concerning the following:
 - Dividing the class into 4 groups and ask them to report after 7 minutes.
 - Home by group 1.
 - Locality by Group 2.
 - Church/mosque by Group 3
 - Country by Group 4.

- A sample of school rules and regulations, Rwandan national Constitution.
- Step 2: - Tell learners that rules and regulations are good to be learnt.
- Command learners to give the benefits of rules to any organisation
 - To promote order.
 - To promote peace.
 - To promote harmony.
- Later guide learners into a discussion of rules of Handball.
- From the informed point of view learners give some of the rules of Handball learnt in the lower classes.
- The game is started by a throw off. The normal playing time for the 16 years and above is 2 halves of 30 minutes.
- A player recognised as a goalkeeper may become a court player at anytime.
- Touch the ball with any part of his body while in the act of defence inside the goal area.
- Throw in is awarded when the ball has completely crossed the sideline.

Goalkeeper's throw

- It is taken by the goalkeeper from the goal area out over the goal area line.

Disqualification

- A third suspension of the same play.
- A player of the throwing team touches or crosses the free - throw line of the opponent.
- The player holds the ball for a maximum of 3 seconds.
- The punishments in the game of Handball include:
 - warning.
 - suspension.
 - disqualification.
 - exclusion.
- Guide learners to explain that punishments are given for:
 - unsportsman like behaviour by a player or team official and to the goal.
 - It is indicated by holding up a yellow card to the guilty.
 - disqualification.
 - exclusion.
 - A 2 minutes suspension shall be given for :
 - (i) faulty substitution (ii) repeated fouls

Cool down

Guide the learners to perform cool down exercises. Let them walk around the activity area, stretch and finally strengthen their muscles.

Final Discussion

Discuss with the learners the importance of rules in the game of handball.

What values do we get when we follow rules of any given game?

How do rules help us in our daily life?

Learners discuss what they have learnt on rules of Handball game.

End of unit assessment

Setting exercise and evaluate how learners use attacking skills and defending skills and interpret rules in the game situation.

Unit Summary 8

In this unit, we have learnt about attacking system, focussing on pivot play, fast break, counterattack; defensive systems with exercises of individual defence (man to man), zone defence, rules of handball and finally the role of a leader in teamwork.

In the next unit, we shall learn about goalball techniques and tactics and also importance of goalball for his/her body and daily life. Finally we shall teach about playing goalball in the society.

Unit Glossary 8:

- Shot** : Throwing the ball into the goal.
- Reverse** : Move backwards.
- Blocking** : Movement that stops another player from going forward.
- Fast break** : A quick attack from defensive position in handball.
- Transition** : To change from defence to attack or attack to defend.
- Pivot** : To rotate on one foot.

UNIT 9: GOALBALL

Content map for Unit 9

Item	Content
Key Unit Competence	Use different defensive and offensive techniques and tactics of Goalball.
List of lessons	1 - Techniques and tactics of goalball
Introduction	In this unit we are going to learn techniques, tactics in attack, and defence in Goalball. We shall also explain reasons for and the importance of playing goalball.
Classroom Organisation	Whole class orientation, individual practise, pair work and group work and free play in the playground.
Equipment required	Balls, rooms, stopwatches, blindfolds, bells, playground, resource person, whistle and relevant books, etc.
Activities	<ul style="list-style-type: none"> - Warm up and cool down activities. - Scoring activities. - Attacking activities. - Defensive activities.
Competences Practised	<ul style="list-style-type: none"> - Recognising the different types of Goalball techniques and tactics. - Explaining the importance and reasons for playing Goalball. - Showing respect of Goalball rules and regulations during game situations. - Appreciating the importance of cooperation in a team - Fair play. - Self confidence and enjoying games.
Language practice	<ul style="list-style-type: none"> - During brainstorming intervals. - In group discussions.
Vocabulary acquisition	Landing, neutral (zones), illegal defence.
Numeracy	<ul style="list-style-type: none"> - Measuring the length and width of the Goalball court. - Counting points scored.
Study skills	<ul style="list-style-type: none"> - Applying techniques and tactics to improve his/her performance in goalball. - Creating individual techniques and tactic gestures.
Learning outcomes	Ability to apply basic techniques and tactics of Goalball in attack and defence.

Cross - cutting issues	<ul style="list-style-type: none"> - Gender: Engaging both boys and girls in all activities. - Inclusive education: Adjusting games respectively to suit all learners' ability. - Genocide studies: Having learners work in groups to appreciate the importance of cooperation in team. - Peace and values education: Telling learners to respect rules and regulations of the game.
Assessment criteria	Setting exercises and evaluating how learners apply basic techniques and tactics of Goalball in attack and defence.

Key unit competence:

Learners will be able to apply basic techniques and tactics of goalball in attack and defence.

Learning objectives:

Knowledge and understanding

- Recognise different types of goalball techniques and tactics.
- Explain the importance of goalball for his or her body and daily life.
- State the reasons of playing goalball in the society.

Skills to be developed

- Apply technique and tactics to improve his/her performance in goalball.
- Create individual techniques and tactics gestures.
- Evaluate his/her performance in goalball.

Attitudes and values:

- Show respect of rule and regulations during the game.
- Appreciate the importance of cooperation in team.
- Fair play.
- Self-confidence.
- Enjoy in playing goalball.

Lesson 1: Techniques and tactics of goalball

Techniques and tactics in attack and defence in goalball.

Teaching methods:

- | | |
|-------------------|---------------|
| - Instruction | - Command |
| - Demonstration | - Discovery |
| - Problem solving | - Explanation |

Teaching and learning materials

- | | |
|---------|--------------|
| - balls | - Playground |
| - room | - Whistles |

- stopwatch
- Goals balls
- Blindfolds
- Bell

Lesson: Development

Introduction

- Guide the learners to perform warming up exercises. They should jog around, stretch and strengthen their muscles systematically.
- This is a sport specifically designed for the blind. It is important to note that learners who are blind are not able to play many sports. However, with goalball, they can also compete in an active sport just like others.

Lesson body

- Step 1:
- Guide the learners through demonstrations to perform the following techniques and tactics of goalball.
 - Throwing and rolling
 - Bouncing
 - Penalty shots
 - Knee position
 - Crouching and diving to stop the ball
 - Blocking the ball in a lying position
- Step 2: Demonstrate to the learners the roles of;
- right wing players
 - left wing players
- Step 3:
- Guide the learners through the rules of goalball and finally implement them in a game situation.

Court

The court should be 18 metres (59 ft) long by 9 metres (30 ft) wide. The goal spans the width of the pitch. The middle two section.

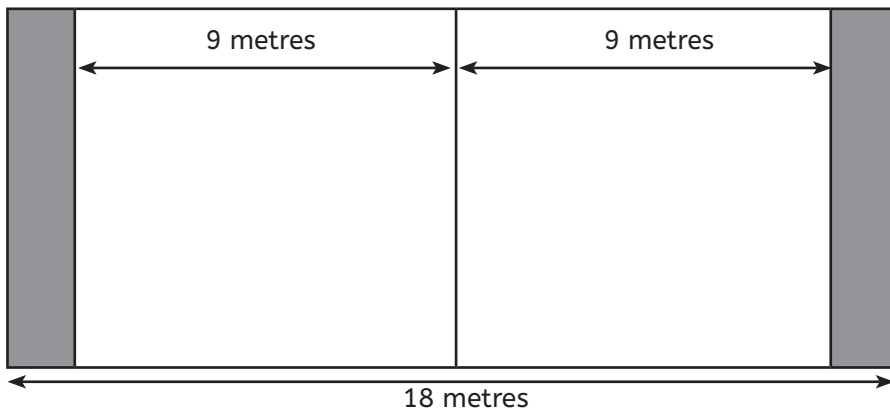

Goalball pitch

The lines of the court are made by placing tape over lengths of twine. This makes the line visible for officials and tactic (easily felt by touch) for players.

Ball

The ball weighs about 1.3 kilogramme. Has eight holes and contains several noise bells.

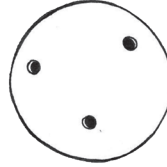

Official

- You will have to choose two referees from students. Each student (referee) remains along the sideline at one half of the court.
- Choose four goal judges. These are positioned to the side of each goal edge. Tell them to be crucial to the game's speed. Also help in retrieving a ball going off court.
- Select a student to act as scorer. He or she keeps track of the number of times out and substitutes taken by a team.

Players

Each team should have 3 players on the court. They should have 1 - 3 substitutes on the bench.

There are three standard positions of play:

- Centre player - Responsible for defence.
- The left and Right wings. Responsible for keeping the ball out of either corner of the goal. They also defend some balls towards the centre.

Scoring

A goal is scored when the ball completely crosses the goal line. The team with the higher score at the end of regulated time is the winner. If no goal is scored during overtime, penalty throws are taken. When a maximum goal difference of ten (10) is reached, a mercy is called and the leading team is declared the winner.

Teaching Points

- Organise learners to complete in teams of three (3) players. All players must be blindfolded. The game consists of 12 minute halves.
- Explain to students how to play the game. It is played by throwing a ball that has bells embedded in it into the opponents goal.
- Teams alternate rolling or throwing the ball from one end of the playing area to another.
- Instruct players to always remain in the area of their own goal, both during defence and attack.
- Tell learners to use their sense of hearing, judge the position of movement at the ball.

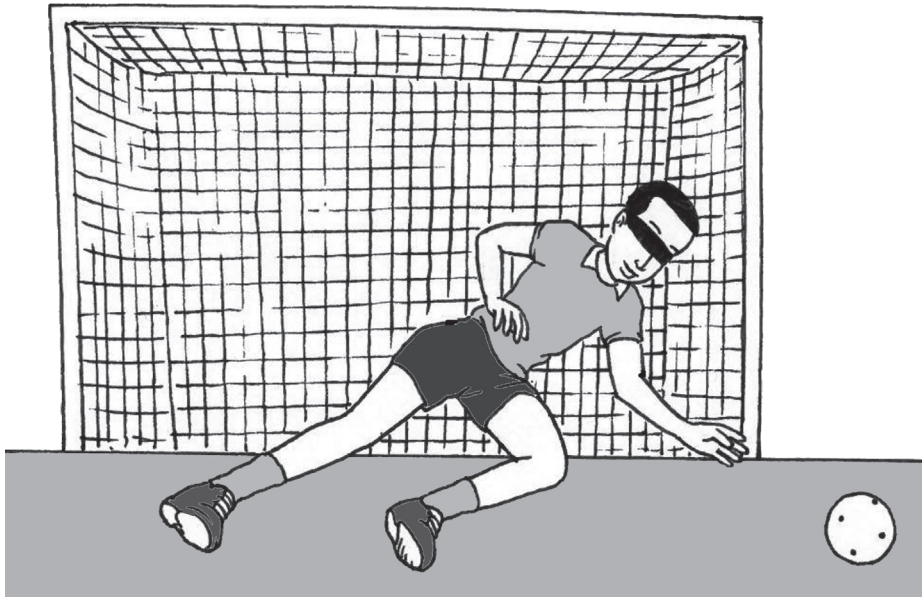

Blindfolded learner trying to catch the ball

(i) Attack (Scoring)

- To score, instruct learners roll or bounce the ball down the length of the court.

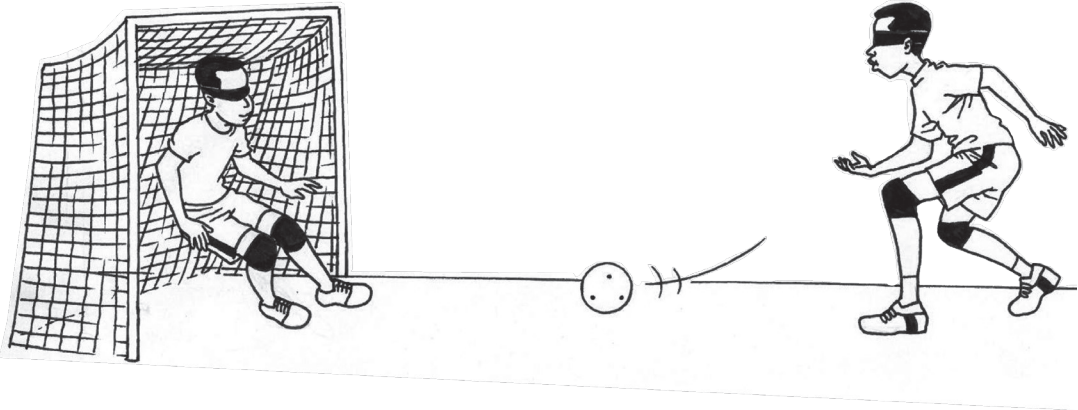

A learner rolling the ball to the opponents goal

- The player with the ball stands, orient him or herself using the tactile lines.
- Command the player to stride forward, lean low and roll or side arm the ball down the court.

Note:

- The ball must touch (hit) in the player's own landing zone and anywhere in the neutral zone.

(ii) Defence

- Instruct the defending players stay within the team area. Advise them to stay somewhat at same position. This avoids collision.
- Tell defenders that when they hear the other team throw the ball, they lay-out, that is slide on their hips and stretch their arms above their heads. Tell them that they should also extend their legs in order to cover as much distance as possible.

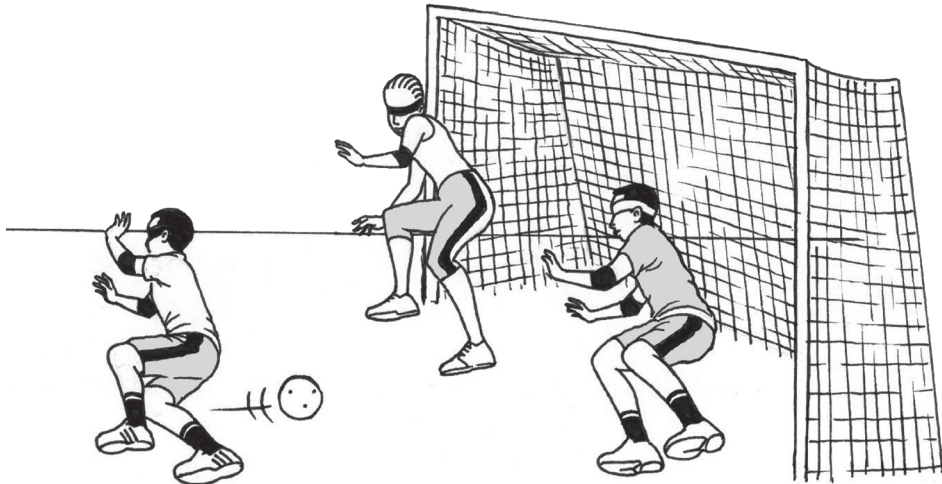

Three defenders diving to stop the ball from entering the goal

- Tell learners that the aim and role of defenders is to keep the ball from getting past the goalline. They are allowed to defend the goal with whatever part of their body. They can block the ball with their chest, legs or hands.

Rules of Goalball

- The player must throw the ball after the official has called 'play'.
- They must not cross the sideline while passing between members of the team.
- If the ball rebounds off a crossbar, defending players, goalpost and crosses back over half court is considered loss of possession to the other team.

Award of penalty

- If a team takes more than ten seconds to throw the ball back over the centre line.
- If the defender makes contact with the ball while no parts of his or her body is touching the team area. It is "illegal defence".
- If the ball fails to reach the opponents team area when thrown. It is regarded as "short ball".
- If the ball does not touch the landing zone when thrown. It is regarded as "highball".
- If the ball does not touch the neutral zone when thrown. It is regarded as "long ball".
- The player must not touch eyeshades or blindfold without permission. If it happens, a penalty is awarded to the other team.

- If the offensive team makes unnecessary noise to prevent the defensive team from tracking the ball while it is rolled or thrown down the court.

Note:

- In the penalty situation, a single player is required to defend the entire goal for one throw. The player who commits the penalty defends the penalty. For example a high ball or illegal defence penalty.

Cool down

Guide the learners to perform cool down exercises. They should stretch and strengthen their muscles systematically.

Final discussion

Discuss with the learners the defensive and offensive techniques and tactics of goalball.

What is the importance of defensive and offensive tactics and techniques of goalball in their daily life.

End of Unit Assessment

Set exercises and evaluate how learners apply basic techniques and tactics of goalball in attack and defence.

Unit Summary

In this unit, we have learnt to apply basic technique and tactics of the goalball in attack and defence and rules of the game.

In the next unit, we shall learn about the different techniques, tactics and rules of sitting volleyball.

Unit Glossary

Landing zone : The opponent's half on the court.

Neutral zone : The midline between the two sections of the court.

Illegal : An area beyond the endlines of the court.

UNIT 10: SITTING VOLLEYBALL

Content map for Unit 10

Item	Content
Key Unit Competence	Use different defensive and offensive techniques and tactics of Sitting volleyball.
List of lessons	1 - Techniques and tactics of playing sitting volleyball.
Introduction	In this unit we are going to learn the different techniques and tactics of sitting volleyball, interpret rules and identify the importance of playing sitting volleyball.
Classroom Organisation	Whole class orientation, individual practise, pair work and group work and free play on the playground.
Equipment required	Balls, stopwatches, chasubles, posts, resource person, net whistle and relevant books, etc.
Activities	<ul style="list-style-type: none"> - Underhand serving exercises. - Blocking technique exercises. - Rotating in position exercises. - Warm up and cool down activities.
Competences Practised	<ul style="list-style-type: none"> - Recognising the different techniques and tactics of sitting volleyball. - Identifying and explaining the importance of sitting volleyball. - Identifying and interpreting the rules of sitting volleyball. - Showing respect of rules and regulations in the game. - Appreciating the importance of cooperation in the team. - Fair play and confidence.
Language practice	<ul style="list-style-type: none"> - During brainstorming intervals. - In group discussions.
Vocabulary acquisition	Underhand, serve, block.
Numeracy	<ul style="list-style-type: none"> - Measuring the length and width of a sitting volleyball court. - Counting points scored.
Study skills	<ul style="list-style-type: none"> - Applying techniques and tactics in a sitting volleyball game situation. - Creating individual techniques and tactics gestures in game situation. - Evaluating his/her performance in the game. - Developing body coordination. - Describing how sitting volleyball can be done in a safe, varied, effective and enjoyable way.

Learning outcomes	Ability to demonstrate techno-tactics gestures of sitting volleyball in attack and defensive system and apply rules in game situation.
Cross - cutting issues	<ul style="list-style-type: none"> - Gender: Engaging both boys and girls in all activities. - Inclusive education: Adjusting the length of the net to suit less abled learners. - Genocide studies: Having learners work together in groups and following rules of the game to ensure fair play.
Assessment criteria	Setting exercises and evaluating how learners play sitting volleyball using techniques and respecting rules and regulations.

Key unit competence:

Learners will be able to demonstrate techno-tactics gestures of sitting volleyball in attack and defensive system and apply rules in game situation.

Learning objectives:

Knowledge and understanding

- Interpret rules of sitting volleyball.
- Explain the importance of playing sitting volleyball.
- Recognise different techniques and tactics of sitting volleyball.
- Recall the importance of sitting volleyball for his or her body and daily life.
- State the reason of playing sitting volleyball in the society.
- Identify rules of sitting volleyball.

Skills

- Apply technique and tactics to improve his/her performance in sitting volleyball.
- Create individual techniques and tactics gestures in game situation.
- Evaluate his/her performance in sitting volleyball.
- Develop body coordination.
- Describe how sitting volleyball can be done in a safe, varied, effective and enjoyable way.

Attitudes and values:

- Show respect of rule and regulations during the game.
- Appreciate the importance of cooperation in team.
- Fair play.
- Self confidence.
- Enjoy in playing sitting volleyball using techniques and tactical gestures.

Lesson 1: Techniques and tactics of playing sitting volleyball

Teaching methods:

- Instruction
- Demonstration
- Explanation
- Command
- Problem solving

Teaching and learning materials

- Balls
- Rooms
- Stopwatch
- Goalsposts
- Playground
- Whistles
- Chasubles
- Nets

Lesson development

Introduction

Guide the learners to perform warm-up exercises. Let them stretch and strengthen their muscles systematically.

Brief learners about the game. This is a game for the disabled. It is sometime referred to as para-olympic volleyball.

Lesson body

Step 1: - Guide the learners through demonstrations to perform the following techniques and tactics:

- underhand serve
- overhead serve
- hit serve
- hitting
- spiking and blocking

Step 2: - Guide the learners through demonstrations to practise the rules of the game.

The Court

It measures sixty (60) feet in length and thirty (30) feet in width. The centre line is marked at the centre of the court. It divides the court equally into thirty (30) feet on each side of the centre line of the court.

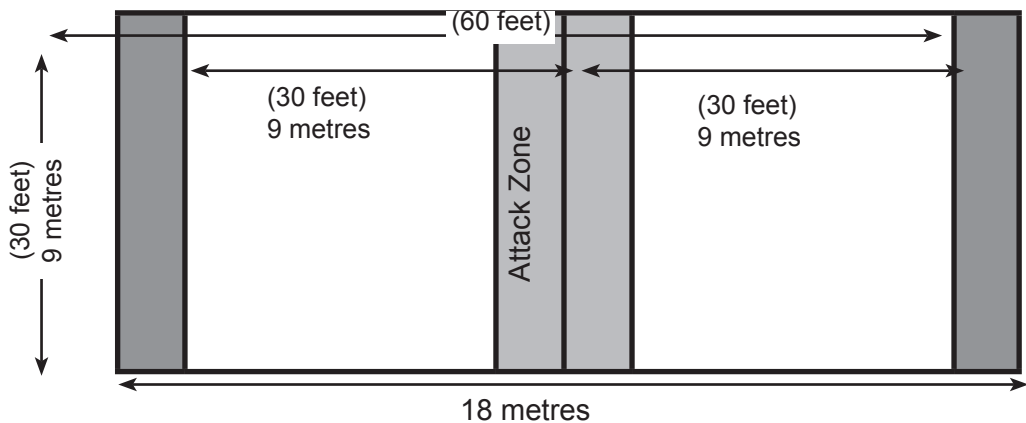

Football pitch.

The Net

This hangs directly above the centre line at about 7 feet for girls and 8 feet for boys.

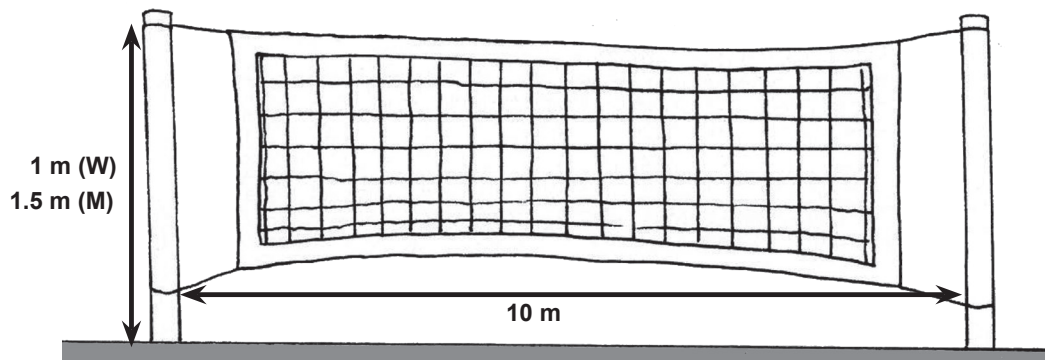

Sitting volleyball net

Attack line

This is marked ten (10) feet on each side of the centre line of the court.

Service line

This is marked 10 feet inside the right sideline of each backline. This is the area from which the server may serve the ball.

(i) Underhand serve

Teaching points

- Explain to the learners that an underhand serve is a type of volleyball serve in which a player holds the ball with one hand, swings the other hand in an arc motion, strikes under the ball with a fist to put it into play.

Note:

Fist means a hand when it is tightly closed with the fingers bent into the palm.



An underhand serve

(ii) **Players**

Teaching

- Demonstrate to learners to hold the ball at eye - level.
- The left-hand put on the bottom of the ball and right on the top of the ball.



Showing left hand on the bottom of ball and right on the top at eye - level

- Toss the ball high enough with the left hand.
- Pull back the right arm and bring it forward with force to meet the tossed ball on its downward swing.



Striking ball tossed with right hand while seated.

(iii) Blocking technique

Teaching points

- Take learners through exercises that can train them the blocking technique.
- Train learners to catch the ball and bring it into their own possession. When catching the ball, the hand and arms should be bent forward, penetrating into the other side of the net.
- The ball needs to be as far as possible.
- Tell the learners (players) that they should not keep their hands and arms straight up when blocking. They are straightened but not pointing straight up.
- The players should catch the ball by placing hands next to each other. Just like in blocking.
- While blocking, player should place two hands next to each other and then turn them slightly around the ball.
- Tell learners to spread their fingers wide and relax them not keeping them extremely flexed and tight.
- Tell learners that relaxing the fingers while blocking helps to put the ball straight down to the opponents's court.



Blocking in game situation sitting volleyball.

(iv) Rotating in position

Teaching points

- It is important that players understand proper technique for rotation.
- A team only rotates if they receive a serve after winning a rally (round).

- Tell players that after receiving the serve, all six players must rotate once clockwise.
- The new server rotates from the right front to the right back of the court.
- Teach learners the role of each player in the defined position.
 - Setter - To set up the hitters so that they could hit the ball.
 - Outside hitter - Hits the ball from the stronger corner.
 - Middle blocker - Blocks every hit. Also moves to form a double block with the outside hitters.
 - Libero - He plays the role of passing the ball, digging the ball and takes place of middle blocker when he or she rotates to the back row.

Basic rules in playing sitting volleyball

- Players must sit down at all times while playing. At least a minimum of one buttock.
- Touching the opponent's court beyond the centre line with a hand is permitted.
- Contacting the opponent's court with any other part of the body is forbidden.
- A Player is not allowed to lift his or her bottom from the court when executing any type of attack - hit.
- The referee must stand to the side of the court because of the height of the net and the fact that players are in seated position.

Cool down

Guide the learners to perform cool down exercises. They should stretch and strengthen their muscles systematically.

Final discussion

Discuss with learners different defensive and offensive techniques and tactics of sitting volleyball. What is the importance of these techniques and tactics in their daily life.

End of Unit Assessment

Set exercises and evaluate how learners play sitting volleyball using techniques and respecting regulations and rules

Unit Summary

In this unit, we have learnt the techniques and tactics in sitting volleyball, identifying and interpreting rules in sitting volleyball and finally the importance of playing the game.

In the next unit, we shall be learning to apply various techniques, tactics and basic rules in the netball game situations.

Unit Glossary

- Underhand** : Hitting the ball at the bottom using one hand to either serve or pass.
- Block** : To stop the ball from going forward.
- Serve** : To throw the ball into the air and smash it.

UNIT 11: NETBALL

Content map for Unit 11

Item	Content
Key Unit Competence	Apply techniques, tactics and basic rules of netball
List of lessons	3 - 1. Techniques of netball 2. Tactics of netball 3. Basic rules of netball
Classroom Organisation	Whole class orientation, individual practice, pair work, group work, playing in a team on the netball field.
Equipment required	Netball, whistle, cones, chasuble, bibs, first aid kit, resource person, playground.
Activities	Instruct learners to demonstrate the technique on individual attacks. In file formation learners line up one behind the other to demonstrate the throwing. <ul style="list-style-type: none"> - Passing exercises - Passing drills - Triangular passing drill - Circular passing drill - Pass and go drill - Attacking drill
Competences practised	Apply techniques, tactics and basic rules of netball.
Language practice	<ul style="list-style-type: none"> - Brainstorming activity of the whole class. - Discussion in pairs and small groups. - Demonstration of skills learnt.
Vocabulary acquisition	Opponent, striker, stationary, attacking
Numeracy	Counting the number of players. Counting goals scored. Counting time used on each match
Study Skills	Receiving, passing, defending. Attacking cooperation force leadership.
Learning outcomes	Ability to develop Netball technical and tactical skills, apply basic rules in a game situation.
Cross - cutting issues	Gender: Allow both boys and girls in practice. All inclusive education giving all abilities of learners a chance to try out the activities
Assessment criteria	Setting exercises and evaluate how learners use techniques of netball in a game situation.

Key unit competence:

Learners will be able to apply techniques, tactics and basic rules of netball.

Learning objectives:

Knowledge and understanding

- Identify different types of netball techniques and tactics.
- Recall the importance of techniques and tactics of playing netball.
- State reasons for playing netball in society.
- State main rules of netball.

Skills to be developed

- Receiving.
- Passing.
- Attack.
- Defending a team .
- Leadership.
- Cooperation.
- Force.

Attitudes and values:

Respect of rules and regulations of netball. Appreciate the importance of cooperation and communication in a team

- Self confidence.
- Fair play.
- Fitness
- Leadership.
- Courage.
- Address.
- Competitive spirit.

Teaching Methods

- Discussion
- Explanation
- Demonstration
- Command
- Instruction

Lesson 1: Techniques of netball

Lesson objectives:

Learners should be able to perform different techniques and tactics of netball.

Teaching methods:

- Demonstration
- Explanation
- Guided discovery

Learning and Teaching materials:

- ball
- first aid kit
- whistle
- Bibs
- cones
- resource persons
- chasubles
- playground

Lesson development:

Introduction

Guide the learners to perform warm-up exercises. Let them stretch and strengthen their muscles systematically.

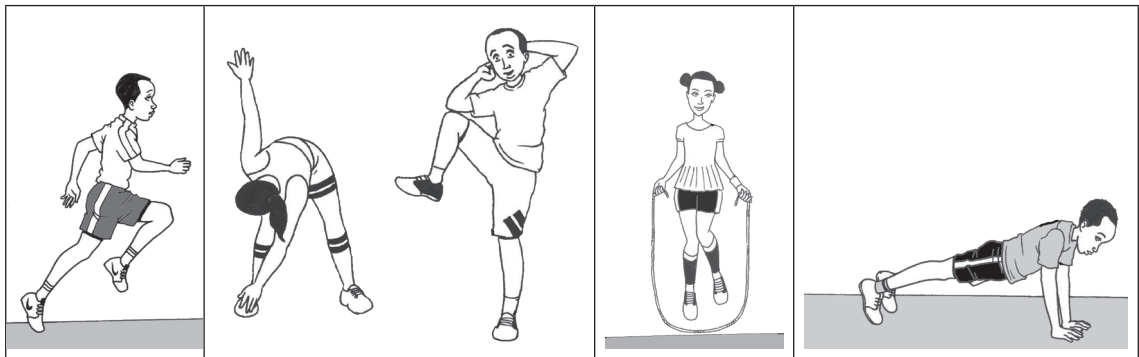

Learners performing warm up stretching exercises

Lesson body

Step 1 : Guide the learners through demonstrations to perform the following techniques of netball.

- Defensive shots
- Landing
- Playing positions
- Throwing in
- Centre court diving
- Posses
- Footwork
- Shooting

Step 2 : Give learners guiding questions about passing (throwing) skills as a technique in netball.

- (1) What is meant by the term passing in netball?
- (2) Mention the different types of passes in netball.
- (3) What should a netball player consider when passes to be performed.

Anticipated responses to the above questions;

- Passing is a technique (skill) in netball that throwing the ball from one player to the teammates. There many different passes. They include basic passes useful to the beginners and secondary skills of passes.
- Through brainstorming, ask learners to mention some of the basic skills of passes which were recently covered in the previous classes.
- Overhead pass, chest pass, bounce pass: These are the basic passes taught to beginners.
- Underarm pass, shoulder pass : These are used by experienced players of netball.

Step 3 : Divide the learners into three groups. Let each group explain and demonstrate each of the above basic pass.

Overhead pass:

The ball can be passed using one hand (Single handed overhead pass) or two hand (two handed overhead pass)

It is advisable to teach the two handed overhead pass for the beginners especially primary learners.

Teaching points:

- Hold the ball with firmly with two hands.
- Spread the fingers around the ball.
- Lift the ball high overhead by swinging the hand behind the shoulders.
- Bend the elbow to lower the ball behind the head.
- Stand straight with the feet shoulder width part.
- Place the stronger foot slightly behind.
- Push the ball upwards by straightening the elbows.
- Swing the hands forward from the shoulder.
- Release the ball as elbows straighten.
- Transfer weight from the back to in front foot.
- Follow through by placing the behind foot in front to enable balance.



Overhead pass

The two handed chest pass

The most common and accurate pass. It is quick and short pass which is used especially when there is no opponent in between the teammates.

Teaching points:

- Hold the ball in two hands at chest level and close to the body.
- Fingers should be well spread on the ball.
- Bend the elbows so that they face sideways.
- Stand straight with feet shoulder width apart.
- Face the direction of throw.
- Extend the arms and hands with palms turning outwards as the ball is released with force.
- Step forward and transfer weight to the forward foot as the arms are extended.
- Follow through in the direction of the pass.

Bounce pass

This is the variation of the chest pass. The ball is held just like that of chest pass. However in the chest pass, two hands are used while one hand can be used for the bounce pass.

Teaching points:

- Hold the ball in two hands at the chest level and close to the body.
- Fingers should be well spread around the ball.
- Bend the elbows so that they face the sideways.
- Stand straight with feet shoulder width apart.
- Face the direction of the throw.
- Ball pushed down the court with force.
- Ball bounces on the ground at a point nearer to the receiver than the thrower about $\frac{2}{3}$ distance between the thrower and the receiver.
- Receiver bends to catch the ball at knee level.



A receiver catches the ball in netball.

Step 5 : Guide and explain the learners to perform the remaining passes. The two remaining passes are used by experienced people (players).

Shoulder pass:

Teaching points:

- Stand feet shoulder width apart with the left leg in front.
- Fingers well-spread out behind the ball, ball resting.
- Transfer weight to hind foot.
- Push from the elbows and shoulders.
- Follow through with a step in of the hind leg.

The under arm pass:

Tell the learners that the flight of the ball is waist high or lower and direct. It is basically used for short passes and the ball travels very fast.

Teaching points:

- Feet shoulder width apart.
- Hold the ball with two hands.
- Withdraw the ball backward.
- Transfer weight to the back foot.
- Give the ball a forward thrust.
- Transfer weight to front leg simultaneously.
- Release the ball in the desired direction with one hand.

Note:

- Emphasise to learners that passes are best used when the surface is hard. In addition, the ball should have enough pressure to enable it balance.

Activity 1: Passing exercises

- (1) State the 3 basic skills when passing a ball in netball game
- (2) Under which circumstances are passes relevant to a netball player:

Additional notes:

- The two handed chest pass;
- This is the most common and accurate pass.
- It is quick and short pass which is used especially when there is no opponent in between the teammates.

Assessment

Learners show an understanding of how passing the ball is appropriately done during practice.

Final discussion

Learner discuss what they have learnt about techniques and tactics in netball game.

Step 6 : Catching (receiving) skills

Tell the learners that catching involves receiving the ball that has been thrown or passed.

Teaching points.

- Extend arms to receive the incoming ball.
- Spread fingers out and form a cup.
- Ball caught in cupped hands that are ball width.
- Hold the ball firmly and turn it so that one hand is above and below the ball.
- Relax elbows and bend to cushion the force of the ball.

Activity 2: Passing drills

In two, three and more practise the drill.

- (a) In pairs let learners receive the ball while stationary.
- (b) Let the learners catch the ball thrown by the partner 7m away six times.

Activity 3: Triangular passing drill

In three s

Learner use triangular formation

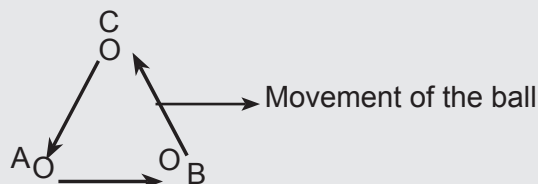

Activity 4: Circular passing drill

In a group

Let learners practise the drill using the circle formation.

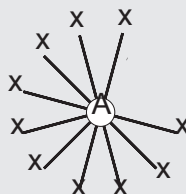

NOTE:

Encourage learners to increase distance as you improve the skill.

- Receive the ball while moving.
- Walk forward to receive an incoming ball from the partner.
- Run forward to receive the ball.

Step 7 : Receiving and catching skills.

Activity 5: Pass and go drill

In a file formation

Learners line up one behind the other facing one direction.

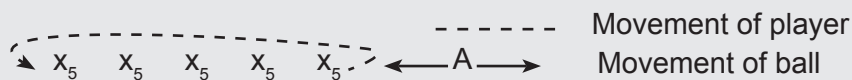

A throws to x_1 who catches passes the ball back and run behind the line.

A throws to x_2 and does the same. Continue until they have had enough practice.

Common faults related to receiving.

The beginners may find problems in receiving the ball if they do not:

- (1) Spread the fingers out and estimate the size of the ball but either put hands too close or far apart.
- (2) From the cup with their fingers and receive the ball with straight fingers.
- (3) Hold the ball firmly once they have received it.

Note: important rules of receiving

The player may not

- Deliberately fall on the ball to catch it.
- Attempt to catch the ball while lying, sitting, kneeling on the ground.
- Catch the ball, drop it and catch it again, double catch.
- Catch the ball and hold it for more than three seconds before passing/ shooting it.

Additional notes:

Receiving as a skill can be practised using double line formation.

- Let the learners try it out to give more room on mastery of the skill.

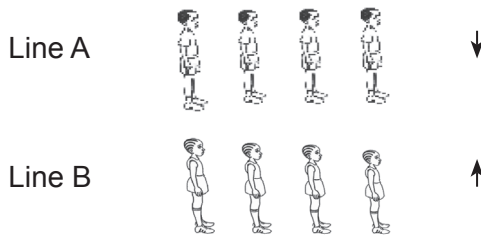

The ball is thrown to the partner who catches it and throws back to the thrower. Continue to practise and increase distance between the partners and they gain more skills.

Note:

The practising can be done when the players are stationary. Then introduce receiving while moving when they improve on the skills. Use as many balls as possible.

Defending a team

Explain the learners that at one point in time, every player of the netball defends the team .

This is done by ensuring possession of the ball hence playing the role of defender.

Teach learners that defending requires each player marks the opponent player in order to try and regain possession of the ball.

Emphasise to the learners that marking require staying close to an opponent in order to intercept or get the ball from her.

Teaching points of individual defense:

- Place yourself closely between your opponent and the ball.
- Stand close but avoid contact.
- Keep the arms down to avoid obstruction.
- Flex the legs and stand on the balls of your feet.
- Keep both your opponent and ball within your field of vision
- When an opportunity arises go all out to intercept.

Note:

As soon as the ball leaves the hand of thrower concentrate on the ball.

- Notice that you can defend a player with or without the ball.

Defending a player with the ball

Bring to the attention of learners that once a player fails to prevent her opponent from receiving the ball, then quickly recover from attempts and take up position in front of the thrower.

Teaching points:

- Stand at least one metre away.
- Keep your body moving with arms and legs covering the opponent as much as possible.
- Do not be deceived by faking, look at the ball throughout.
- Leap into the ball as soon as it leaves the thrower's hands.
- Avoid personal contact.

Note:

Remember the player must throw the ball within three seconds. Therefore try as much as possible to defend her/him so effectively that force a held ball or wild throw.



Defending a player in Netball.

Assessment

- Setting exercises for the learners to reflect what they have covered about techniques of netball.

Cool Down

- Guide the learners to perform cool down exercises. They may include jogging, walking around the netball court and finally stretching their muscles.

Final Discussion

- Guide the learners to discuss about the various techniques of netball.(Passing, receiving and shooting)
- What is the importance of various techniques in netball?
- How do these techniques help us in our daily life?

Lesson 2: Tactics of netball

Learning objective

By the end of the lesson learners should be able to perform the tactics of netball.

Teaching methods

- Explanation
- Practical
- Demonstration
- Guided discovery

Teaching materials

- Balls
- Bibs
- whistle
- Stopwatch

Lesson development

Introduction

Guide the learners to perform warm up exercises. Let them stretch and strengthen their muscles systematically.

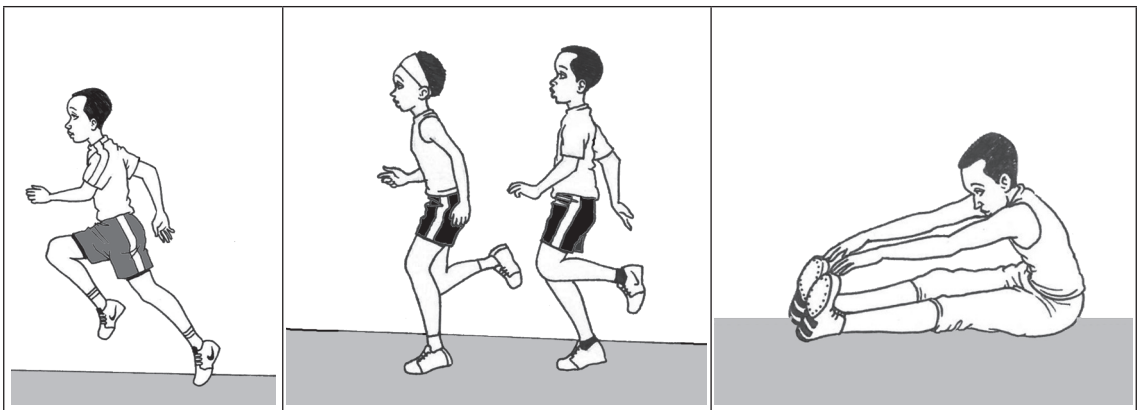

Warm up exercises; fast running, jogging, stretching.

Lesson body

Step 1 : Teach learners that attacking systems in netball consist of;

- (1) Defender
- (2) Midfielder
- (3) Forwarders

Ask learners to suggest the roles of following players in the system.

Defender:

Play behind mid fielders. Usually remain in the half of the field that contains the goal they are defending. The major role is to prevent opponents from scoring. Taller defenders could go into opponent's penalty box when their team is taking corner (Free kick to increase on scoring chances.

Midfielder:

Play between defenders and strikers. Their major role is to maintain possession of the ball. Regain possession of the ball initiate attacking play for their teammates.

Forwards:

Set the players from the attacking center. It is the team in possession of the ball. Major role is to create an opportunity to score. Usually play nearest to the opponent's goal.

Step 2 : Have learners brainstorm ideas about attacking system. Give learners a chance to explain and demonstrate what they know about attacking system

Goal shooter may position her/himself with the goal circle. However this may not give him/her enough chances of dodging the opponent. For that reason wing attack, goal attack and goal shooters must be behind the line separating the centre third from the goal third they are attacking.

Oder of movement

At the sound of the whistle, the WA moves into the centre third to receive the centre pass. On arrival centre passes the ball. GA moves into the goal circle and towards the goal. She receives the pass from GA and GS attempts to shoot.

GA and WA start on the line squeezing their defenders into the middle. This opens up space to run into the shooting circle.

Explain to the learners the relevance of follow up by each player affect her throw. FOH Explain to learners that follow up by each player affect her throw. C to edge of the goal circle via free side of the goal third.

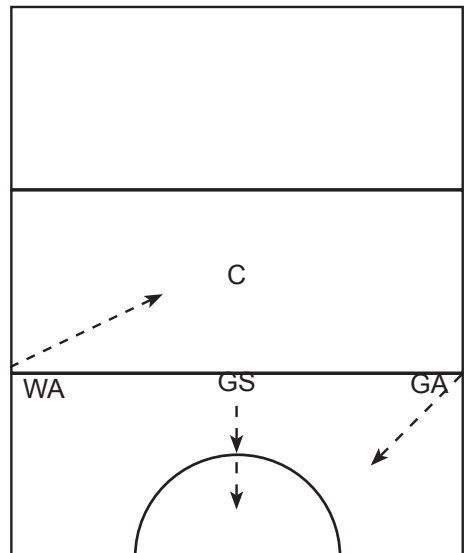

WA through her free side to the goal third, GA to the opposite side of the goalpost away from the GS to catch the rebound shot. GS to the goalpost to catch rebound

Explain some points on attacking

- Ensure faster pass on attacks.
- Don't attempt to attack opponents alone.
- Get your team supporting attack effectively and play with high intensity by improving passing speed.

Note:

When a player pretends and makes diversionary movement in order to get free is an element of tactical skill in the game. (feinting).

Step 4 : Explaining and where possible demonstrating to the learners the importance of tactics the in playing of netball.

Tactics promote good netball playing. For instance, when a player is passing the ball, the player places the stronger leg slightly behind. This will promote balance hence transfer weight from the back to front foot. Remind the learners that two handed overhead pass is suitable for beginners. That is a tactic as well as a technique in playing netball as a game.

Tactics enable players to employ strategies to intercept opponents from advancing to the goal circle of the court. Skills acquired after undergoing several training give them the right ways to defend the circle and how to be good goal defenders.

- Explain to the learners that when defending each player requires to mark an opponent in order to try and regain possession of the ball.
- Let the learners know that marking is an act of staying close to an opponent in order to intercept her/him. It is for that reason that techniques and tactics in netball are considered to be very important.



Player placing between opponents and the ball.

- Tactics enable netball players to respect the rules governing the conduct of the game. In so doing both players and officials will be enabled to enjoy the game. Once a netball player experiences jumping for the ball and predicts to land in the wrong direction he/she changes his mind to land as he uses stationary pivot foot and finally turns quickly.
- Footwork provides the best balance and helps to prepare for cat-like quick movement.

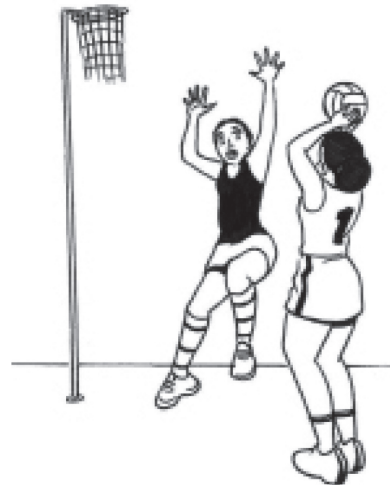

A player demonstrating shooting skills to develop a skill of concentration.

Activity 1 :Attacking drill

Instruct learners to demonstrate the technique of an individual attack with related tactics following the order below.

1. Get free sideways.
2. Get behind the opponent in order not be seen.
3. Feint more to one side.
4. Knees slightly bent.
5. Feet must be comfortably positioned with weight evenly distributed.
6. Sprint to the opposite direction. Like, feint more to the right then spring to the left.
7. Always indicate with the hand perfectly the thumb farther away from the opponent, the direction side is which the ball should be thrown.

NOTE:

Shooting require high level of concentration. Flex the knees and elbows, hold to the ball directly above the forehead.

Force to project the ball comes from straightening the feet upwards, straightening the elbow.

Assessment

Learners will be assessed and evaluated following the content cover by demonstrating and explaining the reasons for using tactics in playing netball.

Cool down:

Guide learners to perform cool down exercises. Let them walk around the netball court 2 times then they stretch their muscles.

Final discussion:

Learners will discuss what they have learnt about techniques and tactics in netball.

What is the importance of techniques and tactics of netball in our daily life?

Additional Notes

The attackers must try to minimise the number of passes so as to decrease the chances or interception.

Shooting is an act of throwing the ball completely into the ring. Shooting is a technique in the conduct of netball game. It is therefore important to train learners specialised throwing skills.

Coaches and trainers plus teachers should always take necessary priority to train throwing skills to the learner.

It should be noted that only two players in the team can perform. These include the goal shooter and goal attacker. This skill is only executed in the goal circle.

Lesson 3: Basic Rules of Netball

Lesson objectives:

Learners will be able to apply basic rules of netball.

Teaching methods:

- Explanation
- Discussion
- Demonstration
- Guided discovery

Learning materials:

- Playground
- Whistles
- Balls
- Chasubles
- Goalposts
- Stopwatch
- Cones
- Net

Lesson development:

Introduction

Let learners brainstorm on some of the netball rules they know.

Tell the learners that you are going to learn about the basic rules of netball.

Guide them in a warm up. Let them jog around and stretch their muscles.

Lesson body

Step 1 :- Let the learners sit in a semicircle in front of a teacher.

- The teacher briefly explains and demonstrates (where necessary) the basic netball rules.

Basic Netball rules

- Player must stay within their designated area.
- Player may not hold the ball for more than 3 seconds.
- Players may not bounce the ball to themselves.
- After gaining possession of the ball, players may take one step only. Taking more than one step is a foul known as stepping.
- Defenders may not stand closer than 90 centimetres to the players with the ball.
- Bodily contact and obstruction are not allowed.

A penalty pass is awarded when a player breaks any of these rules. This means then the opposing player is given a free pass.

A penalty pass at goal is awarded when a defender obstructs or contacts within the shooting circle. The opponent is then given a free shot at goal.

Step 2 : Game situation

- Divide the learners into groups of 7.
- Let them play a game of 7 vs 7 following the basic rules of netball.
- Supervise by encouraging them and correcting errors.
- Those who are not on court should cheer up.

" - Switch teams every after 5 minutes.

Cool Down:

Guide learners to perform cool down exercises. They may walk around the netball court 2 times and then stretch their muscles.

Final discussion:

Learners will discuss what they have learnt about the basic rules of netball.

Guide learners to discuss the values of techniques, tactics and rules of netball.

End of unit assessment

Ask learners to mention and explain the basic netball rules, one at a time.

How do these rules help us in our daily life?

Briefly explain the importance of tactics and techniques of netball.

Additional Notes:

Learners will discuss what they have learnt about the basic rules of netball.

Playing positions

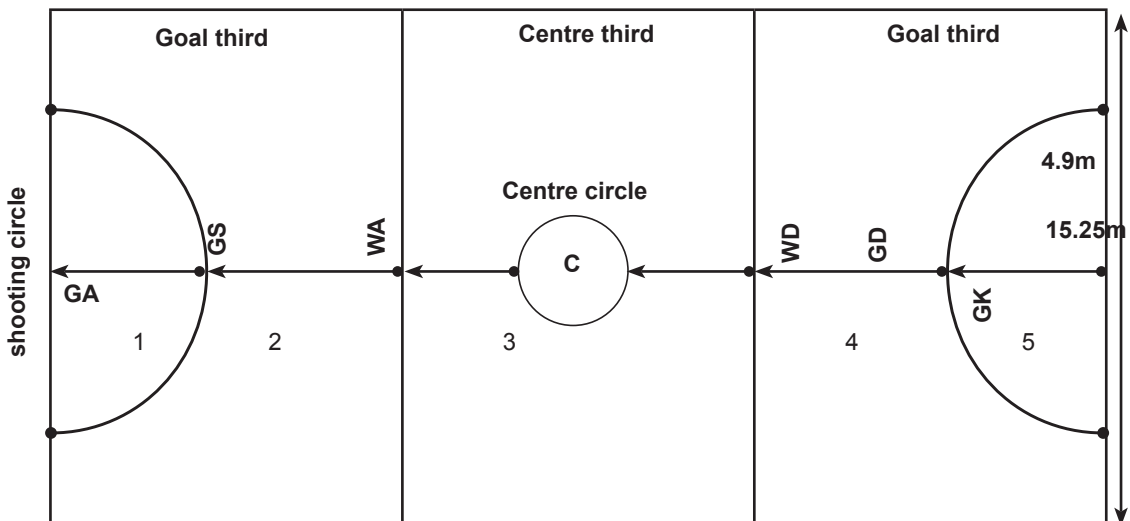

Goal Shooter	(GS)	-	1	2			
Goal Attacker	(GA)	-	1	2	3		
Wing Attack	(WA)	-		2	3		
Centre	(C)	-		2	3	4	
Wing Defence	(WD)	-			3	4	
Goal Defence	(GD)	-			3	4	5
Goalkeeper	(GK)	-				4	5

The playing area for each player is listed above

Teaching points

Explain to the learners that the players with or without the ball is not allowed in any area other than playing for that designated position. If she or she enters or steps on the line Boundary it is considered offside.

Starting the game centre

Teaching points

Explain to the learners that netball as a game starts.

- The umpire blows the whistle to start and restart the play.
- The centre makes the centre pass while standing within the centre circle.
- And the centre pass must be received within the centre third.

Note:

The first centre pass is taken alternatively by two centre players regardless of who scores the goal.

Shooting (Rules related to shooting) Direct learners on the rules related to shooting.

- It is only the goal shooter and goal attacker who are allowed to shoot. Shooting is only done within the goal circle.
- Lines of goal circle are considered part of the circle.
- The shooter must shoot within three seconds of catching or holding the ball.
- Obey the footwork rule.
- Throwing of the is performed completely through the goal ring.

Obstruction

Explain to the learners that obstruction in netball is described as the fact of trying to prevent attacking players from performing a fast break by the defenders.

Obstruction therefore is an attempt by the defenders to block attacking players to pass the ball and later shoot.

Teaching Points

Guide learners on the following points about the relevancy of obstruction to players.

- The player struggling to defend the ball is not allowed to position him/herself on the ground less than 0.9 m (3 ft) from a player in possession of the ball.
- A player may stand closer to an opponent without the ball provided their arms are not extended.
- Distance is measured from the first landed foot of an attacking player to the nearest foot of the defending player.
- Observe keenly that the player with or without the ball is not intimidated (scared) by the opponent.
- Shortening of distance by the defending player to the attacking players is treated as an advantage reducing on the chances to score or shoot.

Foot work

Explain to the learners that once the ball is caught, the player must ensure that there is no movement before passing the ball. Therefore, it is important that a player learns how to land the right foot.

Playing position and their roles on the court

In netball, assign players areas of the court where they are only allowed to perform specific tasks. Emphasise to the learners that once they step into the restricted area in all fairness they are called up for "offside"

Remind players that wearing bibs is relevant because they have position they hold.

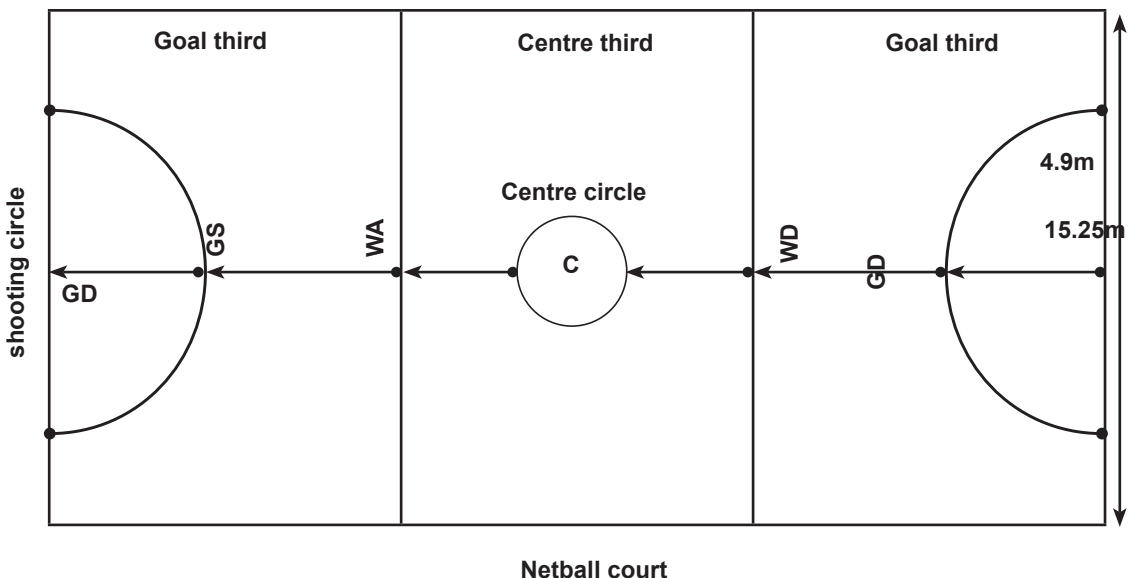

Instruct learners to observe the above netball court and later answer the following questions orally.

- Into how many thirds is the netball court divided?
- Identify the players who occupy the two half circles.

- From which third of the netball court can the centre player be located.
- Through free interactions and discussions, guide learners to identify the position of the different players and outline their roles.

(a) Goalkeeper (GK)

Playing area are the goal third and goal circles.

Tasks:

To defend the goal. This is done by keeping the goal shooter from getting the ball and taking a shot. To prevent the goal third to prevent the ball from making it to the goal circle.

(b) Goal shooter (Gs)

Playing area are the goal third and goal circles and goal third and the goal area of the opposing team.

Tasks:

To take passes in the penalty passes in the goal third.

- To get the ball from the opponents.
- To shoot into the netball hoop.
- To defend closely the opposition GK at goal line throw - ins
- To struggle and make a fast break from
- To work closely with the goal defence in the goal
- To work with the GA, WA and C on attacking strategies in the goal third

(c) Goal Defence (GD)

Playing area are the centre third, goal third and goal circle.

Tasks:

To close "one on one"

- To defend the goal area so as to eliminate attacking moves of their opponents.
- To monitor the opponent's shooter and ensures that she can't get a shot at the goal.
- To force errors, close off spaces, intercept passes of the opponents.

(d) Goal Attack (GA)

Areas of play, centre their, opponent's goal third and goal circle.

Tasks:

- To intercept at opposition centre passes.
- To combine with the goal shooter in order offer a variety of leads in the goal circle.
- To attack the defence of the opposing team.
- To rebound missed shots.
- To feed the ball into the goal circle to the shooter.
- To provide close defending of the opposition GD as defence throw -ins.
- Can also shoot into the hoop.

(e) Wing Attack (WA)

Area of play: Opponent's. team third (attacking goal third and the centre third but not in the goal circle.

Tasks:

- To feed the ball into the goal circle to the shooters.
- To obtain the centre passes.
- To work with the (C) GA and GS on attacking strategies.
- To throw in free pass / penalty pass in goal third.
- To provide close defending of the opponents (WD).
- To deliver the ball to the goal shooter/goal attack using variety of attacking moves.
- To feed the circle.

(f) Centre (C)

Explain to the learners that the centre plays a vital role in a netball game. Area of play: They are allowed to move over the whole court except the goal circle.

Tasks:

- To start the game whenever it is their teams turn to throw the ball.
- To deliver the centre pass.
- To make strong attacking moves, combining with the WA to deliver the ball to the shooters.
- To closely defend opposition centre players.

Unit Glossary 11:

Intercept : To stop the ball from going from one place to another.

Marking : The practice of staying closer to a player (opponent) to stop her from getting the ball.

Wellness : State of being healthy.

Feinting : Confusing an opponent by making a false move to miss-direct his reaction.

Strategically : A skilled way of planning things.

Agile : To be bale to move quickly and in an intelligent manner.

Unit Summary 11

In this unit we have learnt about techniques and tactics of netball, importance of techniques and tactics, playing position and their roles on the court.

Reference

Title of the Book	Author	Publisher	ISBN	Year
Anatomy of The Moving Body: A Basic Course in Bones, Muscles, and Joints	Theodore, J.D., & Megan, D.	California: North Atlantic Books	1556432070	2001
Sportskill Basic	National Association for Sport & Pe & Nas and Human Kinetics	Human Kinetics	9780736037006	2001
Human Growth and Development	Beckett, C.	London: Sage	9780761972495	2002
The Volleyball Coaching Bible	Shondell, D. & ReyNilud, C.	Human Kinetics	736039678	2002
Motivating People To Be Physically Active	Marcus, B. & Forsyth, L.	Champaign, IL: Human Kinetics	9780736040648	2003
High performance sprinting	Smith, Mike	Ramsbury : Crowood	186126755X	2005
Walking Fit	Rose Leach	Collins & Brown	1843403129	2005
The swimming drill book	Guzman, Ruben J	Champaign, IL : Human Kinetics	0736062513	2007
Coaching youth volleyball	Amy Tocco	Champaign, IL : Human Kinetics	0736068201	2007
Basketball : rules, tips, strategy, and safety	Ramen, Fred	Rosen Pub.	1404209921	2007
Assessing Students Outcomes in Sport Education: A Pedagogical Approach	Townsend, J. S.	AAHPERD	883147483	2003
Ready To Use - Motor Skills & Movement Station Lesson Plans for Young Children	Joanne M. Landy & Keith R. Burrridge	Library of Congress	130139432	2000