

Chemistry

Senior One

Student's Book

© 2020 Rwanda Basic Education Board (REB)

All rights reserved.

This document is property of the government of Rwanda.
Credit should be given to REB when the content is quoted.

Table of Content

Unit 1 Chemistry and society.....	1
Introduction	1
1.1 Definition of Chemistry	2
1.2 Importance of Chemistry	3
1.3 Applications of Chemistry in Industry.....	4
1.4 Contribution of Chemistry to the economy of Rwanda	7
<i>Test Your Competence 1</i>	9
Unit 2 Laboratory safety and apparatus	10
Introduction	10
2.1 Definition of laboratory.....	11
2.2: Laboratory safety	12
2.3 Laboratory apparatus	19
<i>Test Your Competence 2</i>	33
Unit 3 States and changes of states of matter	34
3.1 Definition of matter and the states of matter.....	34
3.2 Changes of states of matter.....	36
3.3 Physical and chemical changes of matter	38
3.4 Kinetic theory of matter	46
<i>Test Your Competence 3</i>	55
Unit 4 Pure Substances and Mixtures	57
4.1 Pure substances	57
4.2 Mixtures.....	58
4.3 Methods of separating mixtures	60
<i>Test Your Competence 4</i>	76

Unit 5 Atoms, Elements and Compounds	78
5.1 Definition of element, atom and molecule	78
5.2 Symbols of chemical elements	79
5.3 Main components of an atom	81
5.4 Atomic characteristics	82
5.5 Electronic configuration	83
5.6 Instability of atoms	88
5.7 Radicals.....	91
5.8 Valence of elements and radicals	91
5.9 Chemical formulae and nomenclature.....	91
<i>Test Your Competence 5</i>	95
Unit 6 Arrangement of elements in the Periodic Table	97
6.1 Dobereiner's triads	98
6.2 Historical development of the modern Periodic Table	99
6.3 The modern Periodic Table.....	100
6.4 Relationship between electronic structures of elements and their positions on the Periodic Table	101
6.5 Metallic and non-metallic trends in the Periodic Table	104
<i>Test Your Competence 6</i>	107
Unit 7 Water and its composition.....	109
7.1 Sources of water.....	110
7.2 Physical properties of pure water	111
7.3 Testing for the presence of water in a given substance	112
7.4 Characteristics of different categories of water	113
7.5 Treatment and purification of water	114
7.6 Water cycle.....	116
7.7 Uses of water	117
<i>Test Your Competence 7</i>	119

Unit 8 Air, composition and pollution	120
8.1 Components of air and their percentages.....	121
8.2 Oxygen as the active part of air	121
8.3 Importance of air	122
8.4 Air pollution	123
8.5 Ways of preventing air pollution	124
<i>Test Your Competence 8</i>	<i>127</i>
Unit 9 Waste Materials	128
9.1 Definition of waste	129
9.2 Types of waste materials	129
9.3 Sources of wastes	131
9.4 Sources of waste materials at school level and their management.	131
9.5 Hazards of wastes to environment.....	131
<i>Test Your Competence 9</i>	<i>134</i>
Unit 10 Chemical Equations	135
10.1 Chemical reactions.....	135
10.2 Balancing chemical equations	141
10.3 Interpreting and translating word equations into	
chemical equations	146
<i>Test Your Competence 10</i>	<i>151</i>
Unit 11 Acids, bases and pH	152
11.1 Definition of an acid, base and an alkali	152
11.2 Properties of acids and alkalis	154
11.3 Simple acid–base indicators	156
11.4 The pH of a solution	161
11.5 Applications of acids and bases	164

11.6 Dangers associated with bases and acids.....	165
<i>Test Your Competence 11</i>	168
Unit 12 Inorganic salts and their properties	169
12.1 Definition and nomenclature of salts	169
12.2 Physical properties of inorganic salts	172
12.3 Action of heat on salts	176
<i>Test Your Competence 12</i>	184
Unit 13 Preparation of oxygen and its properties	186
13.1 Methods of preparation of oxygen gas	187
13.2 Physical properties of oxygen	190
13.3 Chemical properties of oxygen.....	192
13.4 Methods of collecting gases	197
13.5 Uses of oxygen gas	202
13.6 Ozone.....	203
<i>Test Your Competence 13</i>	205
Appendices	208
Appendix I	208
Appendix II	209
Periodic Table of elements	210

UNIT 1

Chemistry and Society

You probably have heard of the word 'Chemistry'. What is the importance of Chemistry in the society today? How would life be without Chemistry? Now, look at these photographs.



Fig. 1.1 Some products made using the knowledge of chemistry

Discuss with your friend how the things in the photographs came about. Are they important in our lives?

Key unit competency

After studying this unit, I should be able to assess the applications of Chemistry in our daily lives and state its contribution to the economy of our country.

Unit Outline

- 1.1. Definition of Chemistry
- 1.2. Importance of Chemistry
- 1.3. Application of Chemistry in industry
- 1.4. Contribution of Chemistry to the economy of Rwanda

Introduction

The history of Chemistry dates back to the 8th century AD when a Muslim Alchemist Geber, first described the processes of distillation, crystallisation and sublimation. However, even before this, the ancient humankind had already started using some chemical techniques. For example, early potters used glazes to decorate and preserve

their wares. Early brewers used crude fermentation techniques to make traditional brews, beers and wines. Blacksmiths combined metals such as tin and copper to make bronze, which they used to make various farm implements.

In the modern world, complex chemical processes have been invented to come up with sophisticated products. These products have brought about significant changes in our way of life today.

The knowledge of **Chemistry** has also found relevance in other subject areas such as mining in Geography, manufacture of fertilisers in Agriculture, chemicals of life in Biology and manufacturing and industrialisation in Economics and Entrepreneurship studies. You should therefore endeavour to understand and internalise the various concepts in **Chemistry**. This may in turn help shape your future in terms of your career and life in general.



Fig. 1.2 Alchemist Geber (721 – 815 A.D) – The father of Chemistry

1.1 Definition of Chemistry

Activity 1.1:

Research activity

1. Check the meaning of the word “Chemistry” in the dictionary or Internet.
2. Discuss the meaning of the word Chemistry in your group.
3. Write the definition of Chemistry in your notebook.
4. Compare your definition with that of other group members. Are they the same?

The facts

The word **Chemistry** refers to the study of the composition, structure and properties of substances under different conditions. For example, you may be interested to know what happens when a piece of wood burns or during souring of milk. You may also want to know what happens when a nail undergoes rusting. All these are studied under Chemistry as a subject.

Activity 1.2

1. Look around you. What artificial things can you see or smell?
2. What are those things made of?
3. Think about how the materials that make up the things you have observed are arranged.
4. Did you know that the things you have mentioned change when interfered with? Why would this be the case?
5. Try out these experiments:
 - Light a piece of candle. What happens?

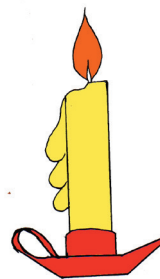

Fig. 1.3: A burning candle

- Put some sugar or salt in a glass of water. Stir using a spoon or stick. What happens to the sugar or salt?

I have discovered that...

There are different kinds of things around us. Examples are pens, books, wires, water, plastics, desks, metals, salt, sugar and soap. Most of these things are manufactured in industries through chemical processes. Others are found naturally on Earth; for example, soil. All these substances are called matter. When different kinds of matter are subjected to certain conditions, they change from one form to another. These transformations may involve a mere physical change or a chemical change which brings about a new product.

The Facts

Chemistry is a branch of Science concerned with the relationship of different kinds of matter and their behaviours under different conditions. This is what is explored in the manufacturing industry.

1.2 Importance of Chemistry

Activity 1.3

- Look at the pictures below.
- Discuss in groups what is happening in each picture.

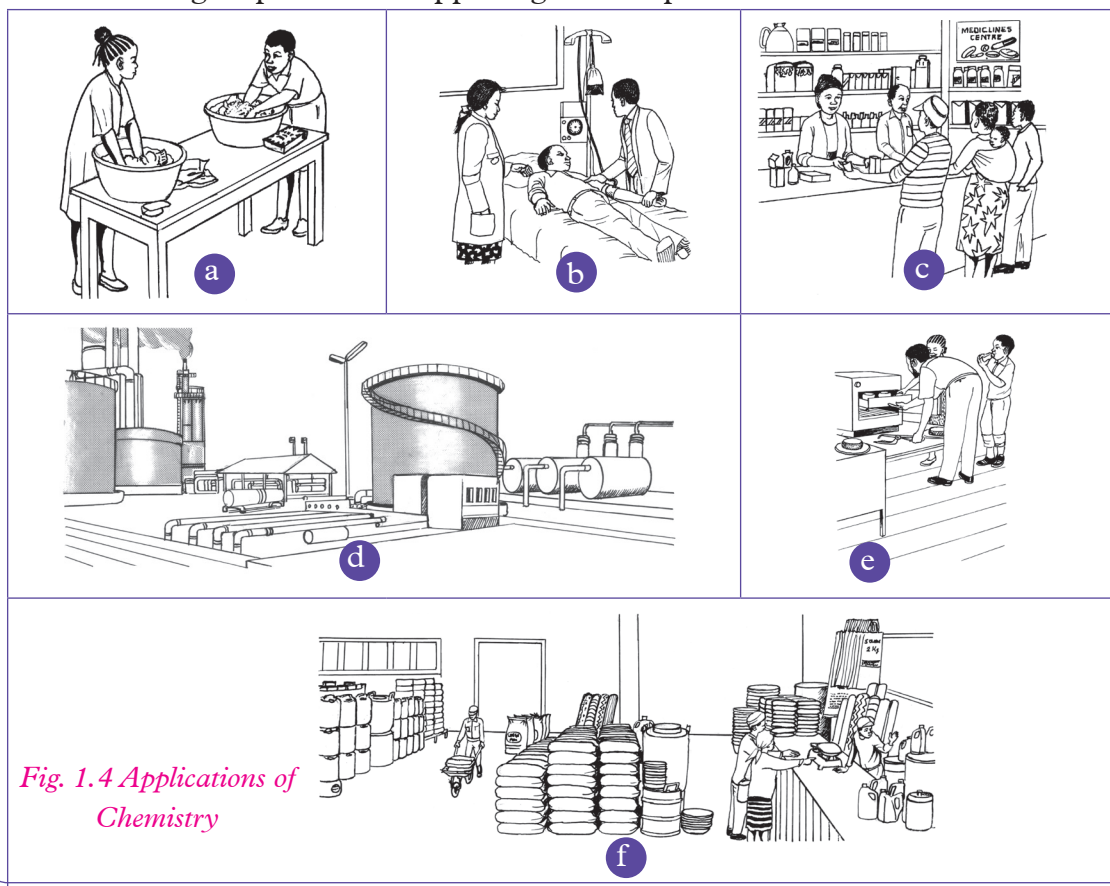

Fig. 1.4 Applications of Chemistry

3. How are the events in the pictures relevant in our lives?
4. What would happen if the events in the pictures didn't happen?
5. Write short notes in your notebook on the importance of Chemistry in our lives.
6. Choose a secretary to do a presentation to the rest of the class on your findings.

I have discovered that...

When we fall sick, we visit the hospital to get treatment. The doctor advises us to buy drugs from the pharmacy. Pharmacists in pharmaceutical companies manufacture drugs that we use when we are sick. We wash clothes using soaps and detergents. We bake bread using baking powder made in industries. We also refine oil from crude oil. In all these, we use the knowledge of Chemistry as a subject.

Therefore, Chemistry plays a very important role in our lives. We should take the study of Chemistry very seriously.

The Facts

Careers that you can pursue after studying Chemistry include:

1. Chemical engineering
2. Quality control
3. Chemistry teaching
4. Veterinary and human medicine
5. Pharmacy
6. Metallurgy
7. Working in a laboratory
8. Nutrition

We are all equal!

It is possible for anybody irrespective of gender or physical state of the body to pursue any career in Chemistry. No career is a preserve of one gender or people without physical challenges!

Self-evaluation test 1.1

1. How will the study of Chemistry help you in your future career?
2. Why do you think the study of Chemistry is important in environmental conservation?

1.3 Applications of Chemistry in Industry

Activity 1.4

Research activity

1. Look at the products given by your teacher.
2. Have you ever come across them?
3. What are they used for?

4. Now, think about the products that you use at home. List them down in your notebook. Compare the products given by your teacher with your list.
5. How important are these products to you?
6. Is there anything that will happen if you fail to use some of the products? Give a list of such products.
7. Where do you think these products come from?
8. How are the products manufactured?
9. What kind of knowledge do you think is required for these products to be made?
10. Your teacher will now take you for a trip in a manufacturing factory. Find out the answers to the questions above during the trip.
11. Write a report and present it to the rest of the class.

I have discovered that...

Many of the products we use at home and in school are important to us in one way or another. Such products include: books, papers, clothes, plastics, tissue papers, toothpaste, bottled water and foods of different kinds. Many consumer products are manufactured in industries through the application of the knowledge obtained from the study of Chemistry.

The Facts

Chemistry has contributed to the understanding of how various materials are manufactured in industries. A good knowledge of Chemistry also helps us to choose safer and better products. The following are some of the areas where knowledge in Chemistry is applied in industry:-

1. Food and beverage industry

The knowledge of Chemistry enables nutritionists to calculate the nutrient composition of drinks and canned foods during the manufacturing process.

This knowledge is also extensively used in the production of traditional brews in Rwanda. Such brews include banana wine, sorghum beer among others. Extraction of butter from milk has been done traditionally to obtain butter used in cooking various types of food. This process also applies the knowledge of Chemistry.

2. Water treatment

Domestic water is treated with chemicals such as chlorine to make it safe for human consumption. Chlorine kills disease-causing microorganisms in water.



Fig. 1.5 A Water Treatment Plant in Rwanda

3. Manufacture of soaps and detergents

In Rwanda, soap is manufactured from oil. This oil is extracted from locally available plant materials. Some chemicals such as sodium chloride and sodium hydroxide are also added during this process. The soap products can be improved by adding colour and perfume to make them more attractive. Knowledge of Chemistry is important in this process.

Quality check!

Always ensure that the soaps and detergents you buy from shops are of high quality and approved by Rwanda Standards Board (RSB).

4. Manufacture of pharmaceuticals

Human and animal medicines are made in pharmaceutical companies. This also applies to vaccines that are used to prevent diseases. The manufacturer of medicine and vaccines apply the knowledge of Chemistry. Traditional medicines in Rwanda are also extracted from leaves and barks of some trees by applying the same knowledge.

5. Manufacture of fuels

Most of the fuel used in Rwanda comes from crude oil. Processing of crude oil occurs in a **refinery**. Examples of fuels include petrol, diesel, kerosene and jet fuel. These fuels are used to run various machines.

6. Other products

Manufacture of products such as clothes, paints, fertilisers and plastic products is done by applying the knowledge of Chemistry.

My environment my life!

Re-use and recycle plastic products. They are not biodegradable. If thrown in the environment, they pollute soil and water i.e. they destroy the soil structure and suffocate useful microorganisms; they can also harm aquatic animals when taken as food or release toxic chemicals in water”



Fig 1.6. An Oil Refinery

Self-evaluation test 1.2

How is the knowledge of Chemistry important in the following areas?

- (a) Water treatment
- (b) Agriculture
- (c) Transport industry
- (d) Pharmaceutical industry

1.4 Contribution of Chemistry to the Economy of Rwanda

In pairs, talk about how Chemistry has helped to shape the economy of Rwanda. Assuming that Chemistry was not there, what would happen? Write a report and choose one group member to do a presentation to the class.

I have discovered that...

The knowledge of Chemistry helps us to transform natural raw materials into products that we use in our daily lives. These products improve our health, productivity and safety. The industries from which the products are manufactured provide jobs and these in turn bring about economic development of Rwanda.

The Facts

The following are some of the ways through which Chemistry helps to develop the economy of Rwanda they include:

1. Through the knowledge of Chemistry, **medicines** and **vaccines** are made available. Some of these medicines reduce infant mortality and hence increasing the size of the population. A healthy population ensures availability of labour to work on farms and in industries.
2. **Manufacture of fertilisers** and animal feeds helps to boost agricultural production in terms of quantity and quality of the products.

3. **Manufactured products** such as beverages, and plastics are exported to earn our country foreign currency. The currency can then be channeled to other sectors of the economy such as education.
4. **In transport industry** - the knowledge of chemistry is applied in fuel processing and in road construction. Efficient transport and communication systems enable easy and faster movement of goods from the production point to the market. This facilitates trade.
5. The knowledge of Chemistry is applied in the **mining industry** to extract minerals. In mines we find chemical engineers, quality control specialists and environmental officers as employees. Minerals act as raw materials for industries. They are also exported to earn the country foreign currency.
6. **Treating drinking water** by the use of chlorine helps to reduce the rate of disease outbreaks. The reduction of disease outbreaks helps the government to channel a larger share of its revenue to other development activities other than the health sector.
7. Through the knowledge of Chemistry, people become aware of the importance of **conserving the environment**. They hence avoid activities such as deforestation and overstocking, which can cause environmental degradation. This in turn helps the government to relocate its resources to other important development projects.

Activity 1.5:

Field trip to a factory

Your teacher will organise a visit to a manufacturing factory, a mining site or an agricultural farm. During the trip, study the processes going on and relate them to what you have learnt about applications and contributions of Chemistry to our economy. Write a report and do a presentation to the rest of the class.

Remember the facts!

- Chemistry is the study of composition, structure and properties of different kinds of matter in different states.
- Chemistry can lead to careers of becoming a doctor, pharmacist, chemical engineer, quality control specialist, nutritionist among others.
- The knowledge of Chemistry is required in the manufacturing and food processing industries.
- Chemistry has contributed immensely to the economy of Rwanda through manufacturing, food processing and pharmaceutical products.

Test Your Competence 1

1. Your friend tells you that she wants to become a medical doctor. Which two subjects must she score highly so as to pursue her career of choice?
2. Explain the link between chemistry and:
(a) Geography (b) Agriculture
3. Briefly explain how the following have contributed to the economy of Rwanda.
(a) Development of vaccines
(b) Manufacture of fertilisers and animal feeds
(c) Efficient transport and communication system
4. Why do you think knowledge of Chemistry is useful in farming?
5. Assume you visited a milk processing plant in your locality. Write a short report that you would use to make a presentation to the rest of the class on the importance of Chemistry in economic development.
6. The following are careers that one can pursue after performing well in chemistry. Which one is not.
A. Quality control
B. Chemical engineering
C. Nutrition
D. Banking
7. An outbreak of a disease whose main symptom is diarrhoea has occurred in a certain cell. Health officers suggest that the outbreak is due to residents drinking contaminated water. With your knowledge of chemistry, what would you advise your friend who lives in that cell?
8. When asked to say the meaning of Chemistry, Senior 1 learners from a certain school gave the following answers:
Learner A – The study of drugs and chemicals.
Learner B – The study of processes taking place in a laboratory.
Learner C – The study of the structure and composition of substances and the way they behave under different conditions.
Which learner do you think was right? Explain

You probably have heard of the word laboratory. Can you tell your friend what goes on in the laboratory? Look at fig 2.1. It shows Marie Curie in her laboratory. Marie Curie discovered the process of radioactivity. Because of this, she won the Nobel Prize for Chemistry in the year 1911. This was the first time a woman won the Nobel Prize. She actually proved that Chemistry is not a preserve of men; that women can also excel in Science subjects!



*Fig 2.1 Marie Curie (1867–1934)
working in her laboratory*

Key unit competency

After studying this unit, I should be able to use effectively laboratory equipment and materials to carry out experiments.

Unit Outline

- 2.1 Definition of laboratory
- 2.2 Laboratory safety
- 2.3 Laboratory apparatus (names, diagrams and uses)

Introduction

Most of the chemicals used in the laboratory are poisonous. Some are highly flammable while others can burn the skin. Also, some of the apparatus and equipment used in the laboratory are highly dangerous and delicate. Below are categories of hazards that may occur in a laboratory:

- Physical hazards
 - Chemical hazards
 - Biological hazards
1. **Physical hazards** are dangers caused by equipment such as tables that may cause a person to trip and fall or glassware that can break and cause cuts.
 2. **Chemical hazards** are dangers posed by poisonous chemicals such as some acids and bases and flammable liquids.
 3. **Biological hazards** are dangers posed by exposure to culture, animal and plant tissues and disease-causing microorganisms.

We should always strive to avoid these dangers while working in the laboratory.

2.1 Definition of a laboratory

Discussion corner!

1. Think of your house at home. Why do you think it has many rooms?
2. What is the purpose of each room?
3. What are some of the items found in each room?
4. Why do you think it is important to take care while using some items in the house?
5. Name some items in the house that are:
 - delicate
 - expensive
 - harzadous

I have discovered that...

Many houses are always built with a number of rooms. Every room is usually reserved for a particular purpose. Some items are kept in certain rooms due to certain reasons i.e. they could be delicate and expensive and can easily be damaged. Similarly, Chemistry is studied in a place known as a **laboratory**. A laboratory is therefore a room, building or institution equiped for scientific research or experimentation.

The Facts

Chemistry as a subject is sometimes learnt through practical activities known as **experiments** done in the laboratory. In the laboratory, you will find equipment, materials and chemicals which are used when performing these experiments. Chemical substances used in an experiment are known as **reactant substances**. Students need to conduct themselves with care and in an orderly manner while in the laboratory so as to avoid injuries and accidents that could occur. Safety rules and regulations have been put in place to guide you as a student when using the laboratory.

A Chemistry laboratory is made up of:

1. **Preparation room**- This is where the teacher usually prepares for the experiment.

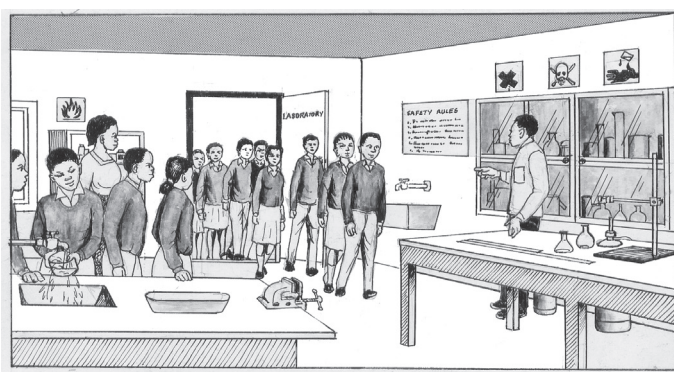

Fig. 2.2 Students entering a laboratory

- 2. Storage room** - this is where laboratory chemicals are kept. It has a lockable cabinet for safe storage of flammable and volatile materials.
- 3. Student working area**-this area has sinks, gas taps and storage cabinets.
- 4. Fume chamber or fume cardboard** - it is used to carry out experiments involving production of poisonous gases.
- 5. Teacher's working counter**-this is usually located at the front centre of the laboratory. It is where the teacher carries out demonstrations on experiments.
- 6. Safety exit** - is a passage used in case of a fire outbreak.
- 7. Shower room**- is used for bathing in case chemicals spill on one's body.

2.2: Laboratory safety

Discussion corner!

1. Think of the reasons why we should always take care when using our roads.
2. What happens when we use our roads carelessly?
3. Discuss some of the rules and regulations that guide road users. Do you see any importance of following those rules?
4. Your teacher will take you to the laboratory. You shall be expected to research and make a presentation on laboratory rules and regulations.
5. Go through the laboratory safety rules in the chart provided by your teacher. Compare it with your findings.

I have discovered that...

*We must always take care while walking along the road to avoid being hit by moving motorcycles or vehicles. Some of the rules and regulations that guide road users include: **do not drink and drive, do not overspeed** and **do not overload** etc. These rules are important in ensuring safety while using the roads. Similarly, we should always follow laboratory rules and regulations to avoid accidents in the laboratory.*

The Facts

Many laboratory chemicals are poisonous while some easily catch fire. Some of the chemicals are also corrosive when they come in contact with the skin. It is therefore necessary that rules and regulations are followed to ensure your safety and that of the others while in the laboratory.

The two common causes of accidents in the Chemistry laboratory are **carelessness** and **ignorance**. Accidents can be minimised when safety rules are strictly observed.

Laboratory safety rules and regulations

The following are some of the laboratory rules that need to be respected while in the laboratory:

1. Do not enter the laboratory without the **teacher's permission**.

2. **Do not run** while in the laboratory because you may trip, fall and injure yourself or others in the laboratory.
3. **Be polite** while in the laboratory; do not push, scramble or fight.
4. **Never taste or eat anything** in the laboratory as these may cause poisoning or infection.

Health check!

Always avoid situations that can put your health at risk. Our health must always be given first priority.

5. Always **consult your teacher** before trying out any experiment, handling apparatus or chemicals to avoid accidents. Do not interfere with other students' experiments in progress.
6. **Do not tamper with electrical, gas or water fittings.** Always turn off water taps and gas taps when they are not in use to minimise wastage.

Money matters!

Help cut costs on electricity, gas and water!

7. **Do not smell gases directly.** Hold the gas source 15-20 cm away from the nose and waft the gas towards the nose using your palm, then smell carefully.
8. Always **hold test tubes or boiling tubes using a test tube holder** when heating to avoid being burnt.
9. **Never look directly into flasks and test tubes** where reactions are taking place because the chemicals might spurt into your eyes and cause injury.
10. Experiments in which poisonous gases are produced must be carried out either in the fume cupboard or outdoor.
11. **Label all reagents** you are using to avoid confusion. Always read the label on all reagents before you use them.
12. Always **use a new spatula each time you are scooping** reagents from a different container to prevent contamination.
13. Always **keep flammable substances away from flames** because they can easily catch fire.
14. **Do not** put hot materials into waste containers.
15. All solid waste should be properly disposed of. **Do not put insoluble materials into the sinks.**

My environment my life!

Proper disposal of wastes ensures an effective working environment.

16. After finishing with a reagent bottle, replace the stopper and **return it in the right place.**
17. **Always clean all the apparatus and bench tops** after use and wash your hands thoroughly before leaving the laboratory.

18. Always **know the locations and operations** of all safety equipment.
19. **Report any accidents to the teacher** or the laboratory technician immediately they occur for necessary action to be taken.
20. If a chemical gets on your skin or in your mouth rinse it immediately with **plenty of clean water.**
21. **Always extinguish flames** that are not in use to avoid accidents and minimise fuel wastage.
22. In case of a serious accident such as a fire or an explosion, **walk out calmly** and do not congest at the exit.
23. **Always wear laboratory coats**, closed shoes, goggles, gas masks and gloves when you are working with chemicals, hot liquids or other materials that could harm you.

Self-evaluation test 2.1

1. Supposing you are going home from school and unfortunately a speeding bicycle knocks down your friend! What action would you take?
2. Why do you think it is important to know the locations and operations of all safety equipment in the laboratory?
3. While in the laboratory, a senior one student accidentally spills a certain chemical on her hand. She immediately feels a burning effect. What action would you suggest to her?
4. What is the first action a student should take before attempting any experiment in the laboratory?

2.2 Laboratory safety precautions and warning labels

Discussion corner!

1. What guides motorists to slow down or take a turn while using certain parts of the road?
2. Why do you think road signs are important?
3. (a) What is a label?
(b) Why do most products have a label?
4. Suppose you came across these symbols, what would you conclude?

(i)

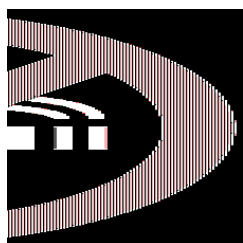

(ii)



5. With the guidance of your teacher, visit a Chemistry laboratory. Look at the

various chemical containers provided by your teacher. Check the safety signs in the containers and list them down.

6. Compare the safety signs in the various containers and their meanings.

I have discovered that...



Road signs and symbols always act as a guide to motorists. They ensure safety and proper use of the roads. Likewise, many products have labels. These labels provide information such as risks associated with the use of the products.



The Facts

In the laboratory, there are symbols and labels majorly to warn the users of the potential dangers. Such dangers usually arise due to ignorance of the laboratory rules or careless handling of reagents and apparatus.

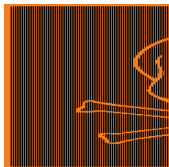
Many of the reagent containers have warning labels on them. Warning labels are small pieces of instructions of care. It is therefore important to read and interpret the various warning labels and symbols. Some symbols are placed at strategic points in the laboratory.

Table 2.1: Laboratory safety symbols and their meanings

Symbol	Meaning
 <p>Highly flammable</p>	– Easily catches fire and burns.
 <p>Toxic</p>	– It can lead to death.
 <p>Irritant</p>	– It irritates the skin when in contact.
 <p>Radioactive</p>	– Dangerous to human health and can cause cancer.

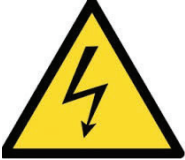
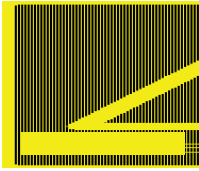
 Corrosive	– Can easily burn you when in contact with your skin. It can also damage wood and metal.
 Explosive	– It can easily explode and release small particles which can injure you.
 Harmful	– Poisonous when inhaled or ingested and can lead to death.
 Electric shock	– It can cause electric shock leading to death.
 Laser radiations	– It can cause cancer.

Activity 2.1:

1. Cut Manila paper into seven square pieces.
2. Using a marker pen, draw various safety symbols on these pieces of manila.
3. Write the meaning of each symbol below it in capital letters.
4. Pin the symbols on the noticeboard of your classroom to remind others of their safety while in the laboratory.
5. Role-play the meaning of each symbol. For example, make a loud noise resembling an explosion. Let your friends try to move away from the scene in an organised way. Also, scratch your skin on the hand as if in pain. Let your friend do first aid on you by pouring a lot of water on the affected part.

Measures to take in case of accidents

Discussion corner!

In pairs, discuss the following questions:

1. Have you ever experienced a cut or a burn? What was done when either of these happened?
2. Where were you taken after being attended to?
3. Why do you think accident victims are usually attended to first before being taken to hospital?

Look at the pictures below.



A



B

4. In pairs, discuss what is happening in each picture?
5. What would happen if nothing was done at all for each of the two cases shown in the pictures?

I have discovered that...

We always face danger of being hurt, cut and burnt as we carry out our daily chores. When an accident occurs, the victim is always attended to in order to reduce pain or severe effects in case an organ is damaged. We therefore must always exercise caution to avoid putting ourselves at risks. We should also know how to use each equipment while in the house. In case of an accident we should always find the appropriate ways of attending to the victims before we take them to the hospital.

The Facts

Sometimes due to carelessness, lack of proper adherence to laboratory rules and regulations, certain accidents are likely to occur in the laboratory.

In case of an accident, **First Aid** is usually done as a first step to getting the victim out of danger and to relieve pain. It may also be done to stop excessive bleeding and to assure the patient of recovery. First Aid is usually given by the use of the components of the **First Aid kit**. A First Aid kit is a collection of supplies and equipment for use in giving First



Fig 2.3. First Aid Kit

Aid. Every laboratory is required to have a First Aid kit. Its location should be known to every laboratory user. The kit is used in cases of emergency.

After the First Aid, the patient is immediately taken to hospital for further check up.

The following are examples of accidents that commonly occur in the laboratory and the measures to be taken .

Table 2.2 Common laboratory accidents and First Aid

Kind of accident	Treatment
<p>Acid and base burns</p>	<p>For damage caused by a minor acid spill, wash the affected part with cold water at once then take painkillers. No other treatment shall be needed. Never burst the blisters. However, if they open, wash gently with soap and boiled water that has been cooled.</p> <p>If the burn is near a movable joint such as an elbow, sterilise a little Vaseline by heating it until it boils and spread it on a piece of sterile gauze. When it is cool, put the gauze on the burn. Never smear on oil or butter.</p> <p>If the burn is not on a movable joint, leave the burn uncovered and allow it to dry. Dab on a gentian violet solution (GV) to help keep it clean and dry. This will help to speed up healing.</p>
<p>Cuts</p>	<p>Raise the injured part for example leg. Wash the injured part using clean water. Use a clean piece of cotton cloth to press directly on the wound. Keep pressing until bleeding stops.</p> <div data-bbox="666 1165 1083 1346" data-label="Image"> <p>The illustration shows a person lying on their back. Their right leg is raised and bent at the knee. A hand is shown pressing a cloth against the lower leg. An arrow points upwards from the leg, indicating it should be raised. Another arrow points to the hand pressing the cloth, indicating the action of applying pressure to the wound.</p> </div> <p style="text-align: center;"><i>Fig 2.4 Pressing the wound</i></p> <p>If bleeding persists, tie the cloth close to the wound as possible. Tighten it enough to control the bleeding.</p> <div data-bbox="467 1493 1278 1681" data-label="Text" style="border: 1px dashed black; padding: 5px;"> <p style="text-align: center;">Health check!</p> <p><i>Always use gloves when offering First Aid to a bleeding patient. HIV and AIDS is transferred through contact with infected blood.</i></p> </div>

Fire outbreak	Use a fire extinguisher in the laboratory to fight the fire. Press the fire bell to alert and then move out everyone in the laboratory.
How to use a fire extinguisher	When there is a fire outbreak, get the fire extinguisher from its location then ask one student to assist you in holding the cylinder while the other holds the nozzle. Remove the safety pin and direct nozzle to the fire source. The carbon dioxide gas released will extinguish the fire.

Self evaluation test 2.2

1. Explain how you would assist a visually impaired member of your group during a laboratory experiment.
2. When walking along a road, at what point do you know it is appropriate to cross?
3. State the measures you will take in case of the following laboratory accidents.
 - (a) Fire outbreak
 - (b) You are cut by a broken glass
 - (c) Acid gets splashed into your eyes
 - (d) Someone accidentally drinks a chemical in the laboratory.
4. Labelling of chemicals in the laboratory is important. Discuss.

2.3 Laboratory apparatus

Discussion corner!

1. If you go to the nearest shop to buy sugar, how would you tell if the amount given to you is right?
2. Suggest the use of the instrument shown in fig. 2.5.
3. How would you tell the volume of water in a container?
4. How can one measure the coldness or hotness of a substance?



Fig. 2.5 Weighing balance

I have discovered that...

*The amount of any substance can only be known after it has been measured using an appropriate instrument. An example of such an instrument is the **weighing balance**. The coldness or hotness of a substance is measured using a **thermometer**. We use a measuring cylinder to determine the volume of liquids etc.*

The facts

We use laboratory apparatus for various functions. The word **apparatus** refers to the set of equipment used by chemists or other scientists to perform experiments. They may be made of metal, wood, plastic or glass. It is important to use the right apparatus when performing a given experiment. One should also be aware of the accuracy of apparatus before using them.

Activity 2.2

1. Using one of the apparatus provided, measure the following volumes of water (20cm^3 , 50cm^3 , 75cm^3 , 100cm^3) and pour into different beakers.
2. Check the temperature reading of a thermometer. This is the room temperature.
3. Move out of the room with the thermometer and record the new temperature reading.
 - Why do you think the temperature reading changes when you get out of the room?
 - Compare your temperature reading with those of other groups. Is there any difference?
4. In pairs, discuss on the suitable apparatus to measure 17 g of sulphur, 20 g of sand, 2.5 g of common salt.

I have discovered that...

Measuring cylinders can be used to measure different capacities of volume. The temperature value recorded in the room is lower than that obtained outside the room. This is due to increased heating from the sun. Due to varying levels of accuracy of the thermometers, different pairs are likely to get different results. An electronic weighing balance is used to obtain more accurate measurements of the mass of various substances.

The Facts

There are different apparatus for different functions in the laboratory. There are apparatus used for measurement of volume, temperature, mass and time. Others are used as a source of heat. Most of the apparatus and reaction vessels are made of **transparent glass or plastic material**. This allows us to observe reactions taking place inside and to also read accurate levels of liquids. Glass and plastics do not also react with most of the reagents used in the laboratory.

(a) Apparatus for measuring volume

Some apparatus used for measuring volume include measuring cylinder, burette, pipette and the volumetric flask.

(i) *Measuring cylinders*

Measuring cylinders are made of transparent glass or plastics. Measuring cylinders have different capacities. They are used for measuring approximate volumes of liquids or solutions.

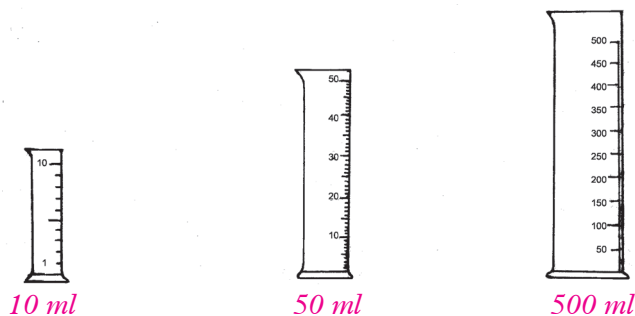

Fig 2.6 Measuring cylinders of different capacities

(ii) *Burette*

A burette is used for measuring accurate volumes of liquids or solutions during chemical analysis.



Fig. 2.7 Burette

A burette has many calibrations and a tap at one end. The tap enables the user to release liquid drop by drop. The zero mark is at the top of the scale. This is because the burette measures how much liquid flows out.

(iii) *Pipette*

It is used for transferring **exact quantities** of liquids or solutions during chemical analysis. Different pipettes measure different volumes of liquid.

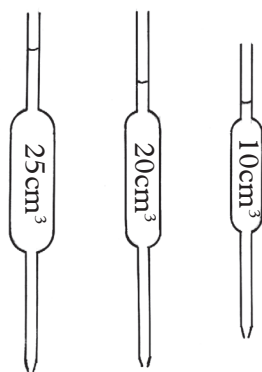

Fig 2.8 Pipettes

A pipette filler is made of rubber and is used to fill up pipettes to the volume mark and to also empty their content.

(iv) Syringes

Syringes are also used to measure accurate volumes of liquid and solutions. Syringes could be of various volumes.



Fig 2.9 Syringe

(b) Apparatus for measuring temperature - Thermometer

Temperature is measured using a **thermometer**. There are different types of thermometers; for example:

- (i) Clinical thermometer
- (ii) General-purpose thermometer

In Chemistry, we use general purpose thermometers. Clinical thermometers are used to measure body temperature in hospitals. They have a bend or a constriction to prevent backflow of mercury after use.

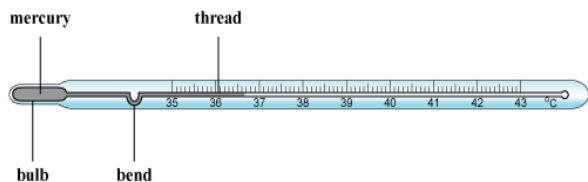

(a) A clinical thermometer

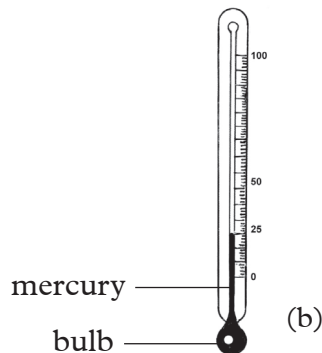

(b) A general purpose thermometer

Fig 2.10 Thermometers of different types

Thermometer readings are usually expressed in degrees Celcius (°C). However, Kelvin (K) is sometimes used.

(c) Apparatus for measuring mass

Mass can be measured using **weighing balances**. There are different types of weighing balances. Examples are **electronic** and **beam balances**. An electronic balance is preferred in measuring more accurate masses of substances. Mass is measured in grams (g) and kilograms (kg).

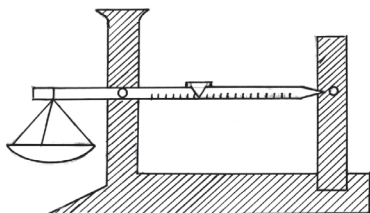

Fig 2.11 (a) Beam balance



Fig 2.11 (b) Electronic balance

Sources of heat in the laboratory

Discussion corner!

Discuss the various sources of heat used at home.

1. (a) Why do your parents prefer the sources of heat you have mentioned?
(b) Is it because they cook food fast or are they less costly?
2. What effect does the sources of heat you have mentioned have on the cooking utensils?
3. Suggest how substances can be heated in the laboratory.

I have discovered that...

We always prefer certain kinds of heating sources because they are less costly and they cook food faster. Besides, some people may choose to cook food using charcoal as opposed to firewood. Firewood produces smoke which tarnishes the surface of utensils. Commonly used heating equipment in the kitchen include stove, gas cooker and electric cooker.

The Facts

In the laboratory, heating substances is always an exciting experience. It is important to use the correct apparatus for heating.

Apparatus used as source of heat in the laboratory include; Bunsen burner, spirit lamp, candles, stove, hot plate, heating mantle and magnetic stirrer with hot plate.

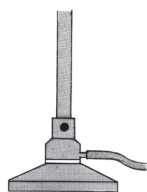

Fig 2.12 (a)
Bunsen burner



Fig 2.12 (b)
Stove



Fig 2.12 (c)
Spirit lamp



Fig 2.12 (d)
Heating mantle



Fig 2.12 (e)
Hot plate



Fig 2.12 (f) Magnetic stirrer with hot plate

A German scientist, **Robert Wilhelm Bunsen** invented the Bunsen burner in 1854. A **Bunsen burner** is the most preferred source of heat in the laboratory. It ensures expected observations are made and that the apparatus holding the reagents are neither damaged nor tarnished.

A Bunsen burner consists of the following parts: the chimney, collar, air hole, jet, rubber tubing and the base.

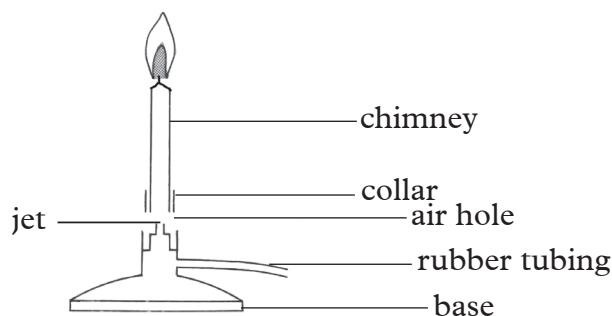

Fig 2.13 The major parts of a Bunsen burner

Functions of the different parts of the Bunsen burner

1. **Chimney** - is a hollow metallic cylinder with an air hole near its lower end. It is designed to raise flame to a suitable height for heating.
2. **Collar** - is a metal ring at the base of the chimney. The diameter of the collar is slightly bigger than that of the chimney so that the chimney can just fit into it. It regulates the amount of air entering the burner by opening and closing the air hole.
3. **Base** - is made of thick metallic material into which a small hollow metal with a jet is fitted. It supports the burner so that it does not topple.

The Bunsen burner is usually connected to an external source of laboratory gas by the rubber tubing. The gas is supplied consistently and the size of the flame is controlled by the size of the air hole. Air mixes with gas if the air hole is open. The size of the air hole is adjusted by the collar. This way, the temperature of the flame can be altered.

How to light a Bunsen burner

Discussion corner!

1. How do you light different sources of heat while at home?
2. Is there a particular set of instructions that must be followed while lighting a source of heat?
3. What will happen if you do not follow those instructions?
4. What precautions should be taken when lighting a Bunsen burner?

I have discovered that...

While at home, we always light different sources of heat in a particular way. This is to avoid the risk of being burnt and also to save on energy. Certain precautions should also be taken when lighting a Bunsen burner.

The Facts

A Bunsen burner is lit following certain steps so as to ensure no fire accidents occur. **Caution!** The process of lighting the Bunsen burner should be carried out with extreme caution to avoid unnecessary accidents!

Activity 2.3

Lighting a Bunsen burner

The following precautions are important in ensuring safety before lighting a Bunsen burner.

1. Ensure that you have a clean working area and a fireproof table.
2. Know where the safety equipment is located and how to use them. These include:
 - **Fire blanket** - this is used for wrapping oneself in case your clothing should catch fire. The blanket will cut off the oxygen supply hence putting off the fire.
 - **Fire extinguisher**- Ensure its inspections are up-to-date. To effectively use the extinguisher, always remember the acronym **PASS**-i.e pull the pin and with the nozzle directed away from you, undo the locking mechanism, aim low i.e at the base of the fire, squeeze the trigger slowly and evenly and sweep the chemical from side to side.
3. Make sure there are no cracks in the rubber tubing, gently squeeze the tubing along the entire length and bend it at several places while you look carefully for cracks. If you see any, replace the tubing.

Steps in lighting the Bunsen burner

1. Connect the rubber tubing to the gas supply and the Bunsen burner. Ensure that the tubing is well fitted on both ends.
2. Make sure that the collar is in position so that the air holes are nearly closed. This will ensure that the flame is at its coolest and visible once the gas is ignited.
3. Before turning on the gas, light your matchstick and slowly run it up the side of the chimney, until it ignites the gas (This is done for safety). Once the flame is lit, put off the matchstick.

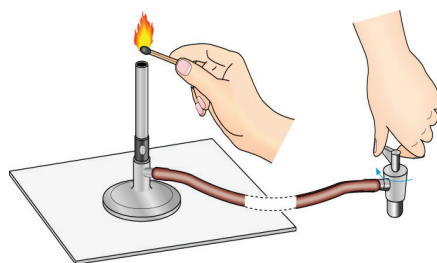
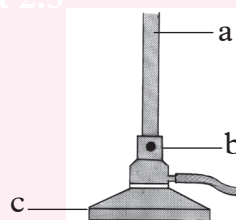

Fig 2.14 Lighting a Bunsen burner

Caution; remember to close the air hole before you ignite the Bunsen burner to avoid **striking back**. Strike back occurs when excess air enters the chimney leading to some weird noise!

Self evaluation

1. What do you observe when you unscrew the chimney from the base plate of a Bunsen burner?
2. What is the function of the parts labelled a, b and c?



Flames of the Bunsen burner

Discussion corner!

Investigating types of flames produced by the Bunsen burner.

1. Let one student lead your group in lighting the Bunsen burner with the air hole closed. Ask for assistance from the teacher if you are still unable to light it. Explain the features of the flame produced in terms of:
 - (a) The colour
 - (b) The shape
 - (c) Smoke produced (if any)
 - (d) Amount of light given out
 - (e) Sound produced (if any)
2. Using a test tube holder, hold a test tube briefly on the flame and note down your observations.
3. Draw and label a sketch of the flame showing the various zones of the flame.
4. Now carefully open the air hole and repeat the above procedure to find out the type of flame produced.
5. Compare the flames you drew with those in the chart provided by your teacher. Identify the flames.
 - (a) What is a flame?
 - (b) Which of the two cases discussed above gives out much more light?
 - (c) Discuss the observations on the test tubes.

I have discovered that...

A flame is the visible, part of a fire. The flame produced when the air hole is closed gives much more light than the one produced when the air hole is open. Soot is observed under the test tube held on the flame produced when the air hole is closed. The other test tube remains clean.

The Facts

With the air hole closed, no air enters the chimney. The flame produced is bright

yellow, large and unsteady. This flame gives out light and is described as **luminous flame**. This flame gives out light because of the unburnt carbon particles in the flame. The particles are due to incomplete combustion resulting from insufficient air (oxygen). These unburnt carbon particles become white hot and produce light. Thus the white-hot carbon particles are responsible for the luminous nature of the flame. They later form black soot which makes the apparatus dirty (Sooty flame).

A luminous flame has four zones namely:

1. The blue region
2. Almost colourless region
3. Yellow region
4. Thin outer region

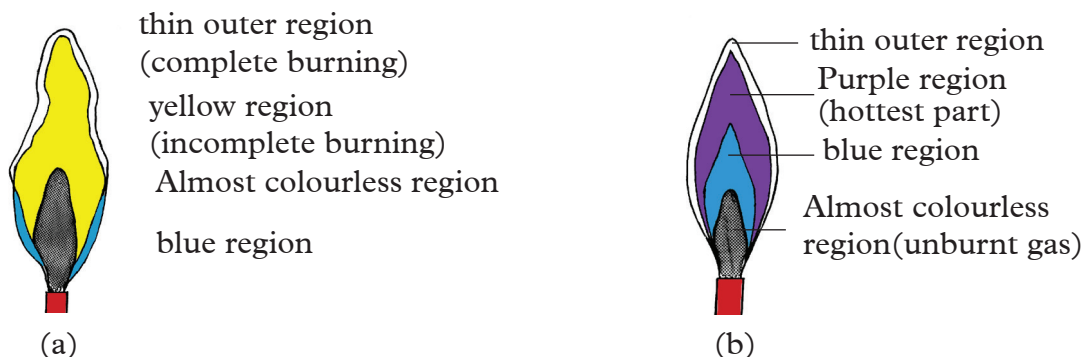

Fig 2.14. Parts of (a) luminous flame (b) Non-luminous flame

When the air hole is open, a lot of air enters the chimney and mixes with the laboratory gas. The mixture burns more quickly and completely. The flame given out is pale-blue and is called a **non-luminous flame**. This is because it does not give out much light. Sometimes it is not easily noticeable.

Non-luminous flames are usually **very hot**. They do not give off smoke i.e. is non-sooty hence it is the most preferred flame for heating in the laboratory.

Heating effects of luminous and non-luminous flames

Activity: 2.4

Determining the type of flame that produce most heat

Apparatus and reagents

Bunsen burner flame, beakers, ruler, measuring cylinder, water, tripod stand, wire gauze.

Procedure

1. Light a Bunsen burner and adjust the collar to produce a luminous flame.
2. Place the tripod stand with wire gauze over it.

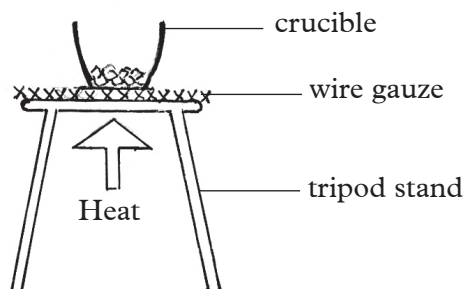

Fig 2.15: Heating using a Bunsen burner flame

3. Measure 50 cm³ of water and pour it into a beaker, place the beaker on the tripod stand.
4. Heat the water in the beaker and record the time it takes to boil.
5. Repeat the experiment using 50 cm³ of water in an identical beaker and heat with the non-luminous flame of the same Bunsen burner. In each case observe the part of the beaker that was in contact with the flame.

Discussion corner!

1. Which of the two water samples took a shorter time to boil?
2. What did you observe at the bottom of each beaker?
3. What type of flame would be suitable for heating.
4. Give reasons for your answer in (3) above.

I have discovered that...

Water heated using the luminous flame takes longer to boil as compared to that heated with the non-luminous flame. The bottom of the beaker heated with the luminous flame appear black (has soot) while the beaker heated using the non-luminous flame is clean (has no soot).

The facts

A non-luminous flame is hotter than a luminous flame. It also doesn't produce soot that would blacken the apparatus.

The luminous flame on the other hand produces less heat. It also produces soot that blackens the apparatus.

The non-luminous flame is hence normally preferred for heating in the laboratory. Luminous flames such as that of a candle flame or lantern lamps are used for lighting.

Money matters!

Always turn off the flames of a Bunsen burner if you are not heating to save the gas.

Activity: 2.5

Apparatus

Bunsen burner, wooden splint or little long wooden sticks, cardboard, matchbox.

Procedure

1. Light the burner and slip a wooden splint across the non-luminous flame for a few seconds. Which are the most burnt (charred) parts?
2. Record your observation.

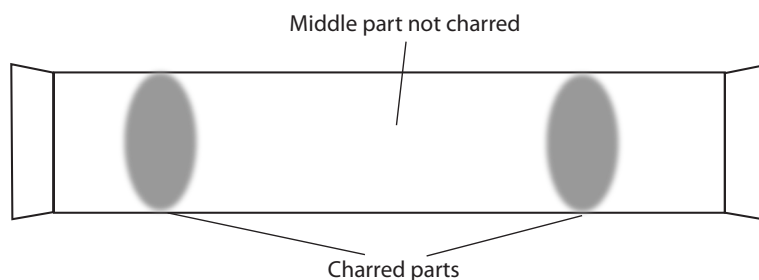

Fig 2.16. A wooden splint burnt across a non-luminous flame

Discussion corner!

1. What do you observe on the splint?
2. Explain the observation in (1) above.
2. Draw the appearance of the splint.

I have discovered that...

When a wooden splint is quickly slipped across a non-luminous flame the splint gets partly burnt in the regions that are in contact with the pale-blue zone. The middle part of the splint remains unburnt.

The Facts

The outermost part of the non-luminous flame is hotter than the inner zones. An object being heated should therefore be placed at the outermost region of the flame. It should also not be placed very close to the base of the flame.





Differences between luminous and non-luminous flames



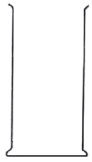

Luminous flame	Non-luminous flame
1. Large and unsteady	1. Short and steady
2. Produces soot	2. Does not produce soot
3. Burns quietly	3. Burns with a roaring noise
4. Fairly hot	4. Very hot

Other laboratory apparatus

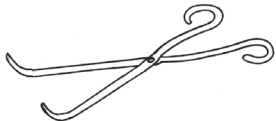
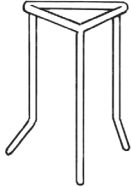
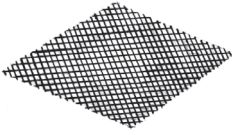
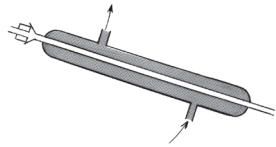
Table 2.3 Other commonly used laboratory apparatus

Name of apparatus	Diagram	Use
Conical flask		Heating liquids, swirling, filtrations and sometimes holding solutions

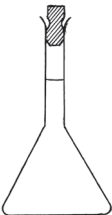
Name of apparatus	Diagram	Use
Gas jar		Collection of gases
Evaporating dish		Used in evaporation to separate solutes from solvents
Deflagrating spoon		Used when burning solid substances like phosphorous
Spatula		For scooping solid chemicals especially when weighing
Pair of tongs		For grasping and lifting materials including hot ones
Tripod stand		For supporting beakers while heating liquids
Wire gauze		Placed between a beaker and tripod stand during heating of solutions. It ensures even distribution of heat
Liebig's condenser		For fast condensation (conversion of steam to liquid) to take place

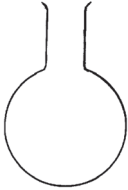
Name of apparatus	Diagram	Use
Flat-bottomed flask		For heating liquids and to contain chemicals
Thistle funnel		Used when adding liquids to existing system of apparatus
Volumetric flask		Used to prepare accurate volumes of solutions.
Filter funnel		For carrying out filtration. Used together with a filter paper.
Teat pipette		For measuring volumes of solutions dropwise.
Round-bottomed flask		For heating of solutions, contain chemicals and distillation

Other common apparatus

Tubes-There are different kinds of test tubes for different uses.

- Ignition tubes** are used for decomposition of compounds.
- Ordinary test tubes** are used for heating substances.
- Boiling tubes** are used for boiling small amounts of liquids.

Beakers—Are vessels made of plastic or glass. There are beakers of varying capacities. Beakers are used as containers for holding liquids and sometimes for boiling liquids. Beakers used for boiling purposes are made of either glass, pyrex or borosilicate. **Flask** - They are used as containers for holding, mixing and sometimes heating solutions.



Fig 2.9: Beaker

Self evaluation Test 2.4

1. Name any other two apparatus that can be used for heating in the laboratory a part from the Bunsen burner.
2. What is the name of the flame produced when the air hole of the Bunsen burner is open?
3. Explain briefly why the luminous flame produces light while the non-luminous flame does not.
4. Complete the table below.

Apparatus	Uses
	Transferring accurate volumes of liquids
Volumetric flask	
Ignition tube	
	Separating immiscible liquids

Remember the facts!

- Laboratory safety is important when working in the laboratory.
- The materials used in the laboratory for performing experiments are called **apparatus** while the chemicals used in the experiments are known as **reagents**.
- A Bunsen burner is the major source of heat in the laboratory. It produces a luminous flame when the air hole is closed and a non-luminous flame when the air hole is open.
- The non-luminous flame is hotter than the luminous flame.
- A luminous flame produces light while a non-luminous flame does not.

Test your competence 2

1. (a) identify the flames shown in the diagrams below.

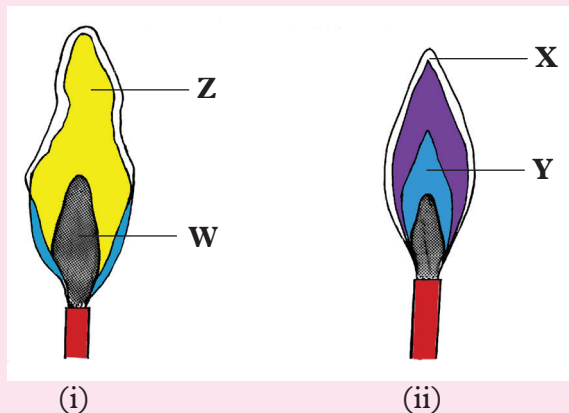

- (b) Name the parts labelled **X** and **Y**, **Z** and **W**.
2. (a) Suggest the appropriate apparatus for holding test tubes when heating liquids.
(b) Explain your answer in (a) above.
3. (a) Draw a pipette.
(b) Explain why most laboratory apparatus are made of glass.
4. Which piece of laboratory apparatus would be most suitable for each of the following activities?
- Holding 50 cm³ of boiling water
 - Melting a crystal over a Bunsen burner
 - Pouring 50 cm³ of acid from one container to another.
 - Measuring exactly 30 cm³ of water
 - Removing substances from a reagent bottle
 - Weighing 100 grams of sodium chloride
5. Provide appropriate answers to the following questions.
- When should safety goggles be worn?
 - How should we handle and dispose broken glassware?
 - If you accidentally spill water near electrical equipment, what should you do?
6. (a) What precautions should you take when heating solutions in a test tube?
(b) It is always appropriate to dispose chemicals by flushing them down the sink. Explain.
Caution! Lead compounds should not be disposed off down the sink.
(c) What precautionary steps should you take when performing an experiment that involves release of poisonous gases?

UNIT 3

States and Changes of States of Matter

Majority of things that we see around us are said to be examples of **matter**. What is matter? Can you name some things that are matter around you. The whole concept of matter was coined at around 400 BC by Greek Philosophers **Democritus** and **Aristotle**.

According to Democritus, if you cut matter into smaller and smaller pieces, you end up with its smallest bits which cannot be cut further. He called these ‘**atomos**’ which there after came to be known as ‘**atoms**’.

Aristotle, at around 350 BC, modified the Democritus theory to state that matter was made up of four elements namely: **fire**, **earth**, **air** and **water**. His theory persisted

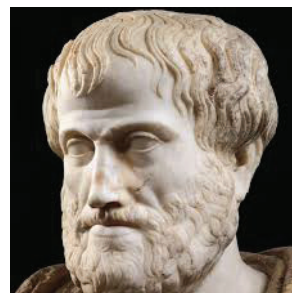

Fig. 3.1 Aristotle



Fig. 3.2 John Dalton

for about 2000 years and was later dismissed and replaced by the modern day **atomic theory** proposed by English Scientist **John Dalton**.

Atomic theory was as a result of experimentation into the nature of matter. It paved the way for deeper understanding of what happens during chemical reactions. This unit is about the various states of matter. So then, what is matter? What are the various states of matter? What happens when various forms of matter are subjected to different conditions?

Key unit competency

After studying this unit, I should be able to relate properties of matter to daily life, physical and chemical phenomena.

Unit outline

- 3.1 Definition of matter
- 3.2 Changes of states of matter
- 3.3 Physical and chemical changes
- 3.4 Kinetic theory of matter

3.1 Definition of matter and the states of matter

Discussion corner!

1. Look around you, inside and outside your class.
2. Name some of the objects you can see, smell or touch. Classify them into those that occupy volume and those that have weight.

3. How can you know that an object occupies volume and has weight?
4. Add more water to a glass that is already full of water. What happens?

I have discovered that...

Objects such as books, pens, trees, water, animals, stones and soil can be seen and felt. All these objects occupy volume and have weight.

If an object is heavy, then it has weight. you add more water to a glass full of water. The excess water spills over. Water occupie volume.

All the objects mentioned in the discussion corner that have mass and occupy volume are made up of some materials.

The Facts

All substances that are found in nature are made up of **matter**. Matter is anything that occupies volume and has mass.

Matter can be put into three different groups, that is:

- **Solids** - for example soil, chalk, salt, sugar, wood and metals.
- **Liquids** - for example water, kerosene, milk and spirit.
- **Gases** - for example air, biogas, oxygen and carbon dioxide.

These three groups are commonly known as **states of matter**. Each of these states of matter has characteristic properties.

The following table gives characteristic properties of the three states of matter.

Table 3.1 Properties of the three states of matter



Solids	Liquids	Gases
1. Have fixed shape and volume.	Have fixed volume but occupies the shape of the container.	Have no fixed shape or volume.
2. Have rigid particles which vibrate within fixed positions.	Particles slide past one another more slightly.	Particles move very fast.
3. Cannot be compressed at all.	Can be compressed to a very small extent.	Very compressible.
4. Do not flow at all.	Flow easily.	Flow very easily.
 <p>Solid state</p>	 <p>Liquid state</p>	 <p>Gaseous state</p>

Fig 3.3. Illustration of the three states of matter

Self evaluation test 3.1

1. Name the three states of matter.
2. Classify each of these items into the three states of matter: Books, ozone, air, milk, water, trees, salt and chalk.
3. (a) What are some of the things around you that are not matter?
(b) Why do you think they are not considered to be matter?

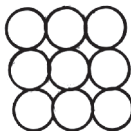
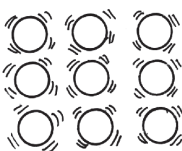
3.2 Changes of states of matter

Discussion corner!

1. (a) What can you conclude when you wake up and find a lot of water droplets on grass yet it was hot and dry the previous day?
(b) Does this water remain on the grass the whole day?
2. (a) What happens to a candle as it burns?
(b) What causes the change in 2 (a) above?
(c) Can the burnt candle be remoulded?
3. What happens when wood is burnt in limited supply of air?

I have discovered that...

Water droplets on grass are formed due to conversion of water vapour in the atmosphere into moisture. In the course of the day as temperature increases, the moisture again turns into vapour.

*If you light a candle, it gives out light as it changes to liquid form. After this change, the melted wax can still be used to make a new candle. This is called **remoulding**.*

When wood is burnt in limited air supply, charcoal is produced.

The facts

Matter can be converted from one state to another.

Activity 3.1

Investigating melting

Reagents and apparatus

Bunsen burner, cooking fat, piece of ice, matchbox, glass beaker.

Caution! Remember the correct procedure of lighting the Bunsen burner to avoid accidents in the laboratory.

Money matters!

Put off Bunsen burner after heating to save gas. Also use the cooking fat sparingly.

Procedure

1. Put some cooking fat in a beaker.
2. Place the beaker over a non-luminous flame. Observe what happens to the fat.

Question: How would you produce a non-luminous flame from a Bunsen burner?

3. Take the melted fat and place it in cold water. Note the changes.
4. Repeat procedures 1 and 2 with a piece of ice and note down your observations.

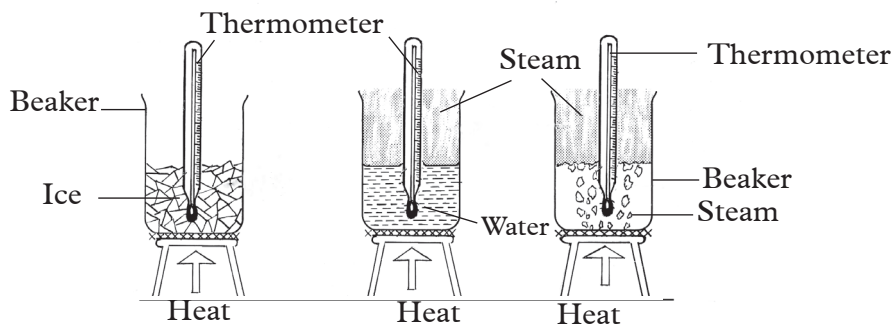

Fig 3.4 Different forms of water at different temperatures

Discussion corner!

1. At what temperature does the cooking fat change its state?
2. Explain what happens to the fat when placed in cold water.
3. What happens to ice when placed over the flame?

I have discovered that....

When the cooking fat is heated, it changes into liquid form. This also happens when ice is heated. When placed in cold water, the liquid fat changes back to solid.

The Facts

When some solids are heated they change into liquids. This process is called **melting**. When the liquids are cooled they change back into the solid state. This process is known as **freezing**.

When a piece of ice is heated, it changes into liquid water. The water slowly changes into vapour with continued heating. The process through which water changes state from liquid to gas is known as **evaporation**. When the vapour is cooled, it changes back into liquid form. This process is called **condensation**. It is also possible to change a solid directly into a gas. This is called **sublimation**. However, when a gas changes directly to a solid; the process is called **deposition**.

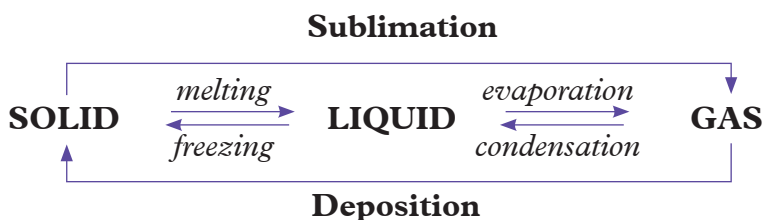

Fig 3.5. Illustration of the process involved in the changes of states

3.3 Physical and chemical changes of matter

There are two types of changes that matter can undergo; namely:

- Physical change
- Chemical change

In activity 3.2, when the cooking fat and the piece of ice are heated, no new substances are formed. The processes are also reversible. Such changes are known as **physical changes**. A physical change is also known as a **temporary change**. Some changes lead to the formation of new products. Such changes are irreversible. They are referred to as **chemical changes**. A chemical change is also referred to as a **permanent change**.

(a) Physical Changes

Experiments demonstrating physical changes

Activity 3.2

Investigating changes that occur when ice is heated

Apparatus and reagents

Ice, thermometer, beakers, Bunsen burner and tripod stand, wire gauze

Procedure

1. Half-fill a beaker with some ice.
2. Put in the thermometer carefully immediately into the ice and record the steady rise in temperature.
3. Arrange the apparatus as in figure 3.6 (The teacher will demonstrate how to arrange the apparatus then one member of your group will guide the other members) and heat the ice gently while carefully stirring with the thermometer. Record your observations.

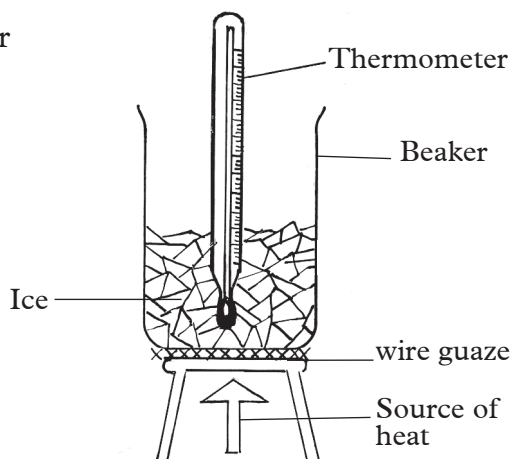

Fig 3.6 Different forms of water at different temperatures

Fairness is my other name!

Ensure you record accurate readings obtained from your thermometer. Never use other people's readings or use guess work. Be honest!

4. Record the temperature of the ice every 30 seconds in the table provided until all the ice melts. Continue heating while recording the temperature until boiling occurs.

5. (a) After boiling, continue heating for about two minutes. Record your results in a table like the one shown below.

Time (Sec)	0	30	60	90	120	150	180	210	240	270	300
Temp (°C)											

- (b) Plot a graph of temperature (vertical axis) against time (horizontal axis).

Discussion corner!

- What does ice form when it melts?
 - Did temperature change during melting?
 - Give a reason for your answer in 2(b) above.
- What does water change to when it boils?
 - Did temperature change during boiling?
 - Give a reason for your answer in 3(b) above.
- Why is the thermometer used in this experiment?

I have discovered that...

When ice is heated, its temperature rises steadily until it reaches 0°C . At this point, ice changes into liquid water.

The temperature remains constant at this point as ice changes to liquid water despite the fact that heating continues. This process is called **melting**.

On further heating, the temperature rises steadily up to 100°C when the liquid water starts to change to vapour.

Again the temperature remains constant as the water changes to vapour. The process of a liquid changing into vapour is called **evaporation**.

Thermometer in this experiment enables us to know the temperature at which change of state occurs.

The facts

The graph below shows heating of ice until boiling starts.

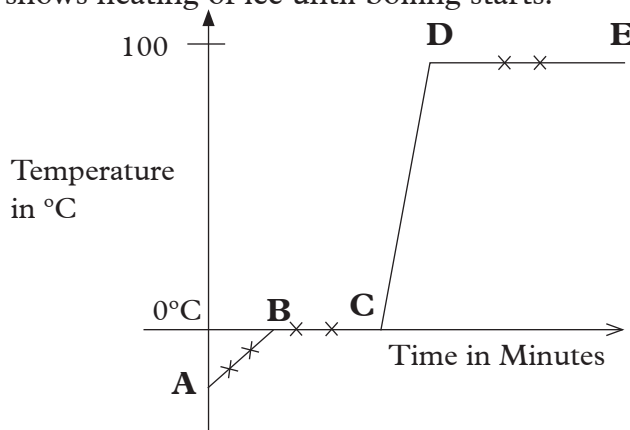

Fig 3.7 Heating curve of ice

We can explain what happens in each region as follows:

- **Region AB:** The temperature rises steadily as the ice absorbs heat energy. The temperature rise stops at 0°C .
- **Region BC:** The temperature remains constant (0°C), until all the ice has melted. This is because the heat energy absorbed in this region is used to break the forces of attraction holding the solid particles together. Water changes its physical state from solid to liquid form at this point.
- **Region CD:** Temperature rises steadily as the liquid water absorbs heat energy. The temperature rise stops when the liquid water starts changing into vapour (evaporation).
- **Region DE:** The temperature remains constant as the liquid water changes into water vapour. Heat energy absorbed is used to break the forces of attraction holding water particles together. Water thus changes into vapour.

Changes that occur when ice is heated can be illustrated in the following flow diagram.

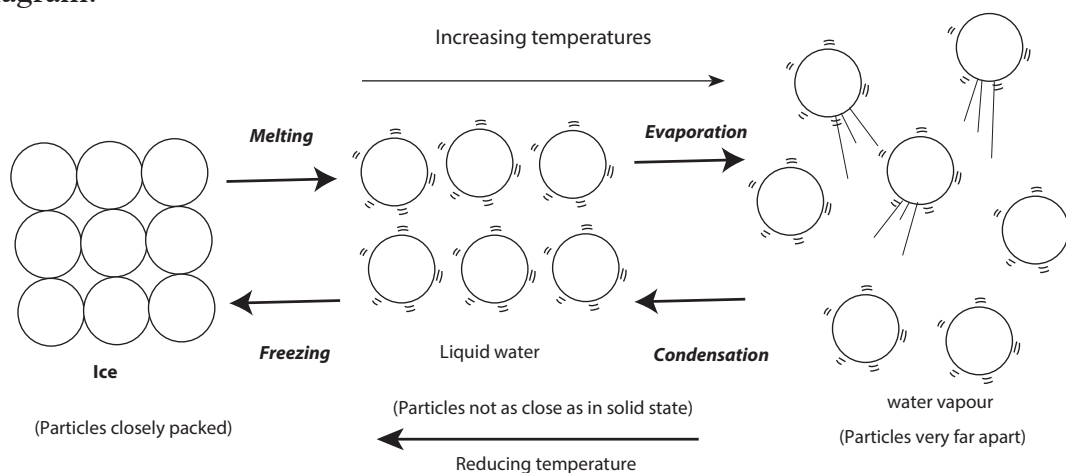

Fig. 3.8 Flow chart showing change ice to liquid then to vapour.

The changes of state from solid to liquid and liquid to gas can be reversed by cooling. On cooling, the gas **condenses** into liquid and finally the liquid **freezes** into solid as shown in the flow diagram.

Activity 3.3

Investigating melting and sublimation

Apparatus and reagents

Candles, iodine, naphthalene, boiling tubes, water, spatula, a pair of tongs, electronic weighing balance, a jar and Bunsen burner

Procedure:

1. Light a candle. Let the candle burn and record your observations.

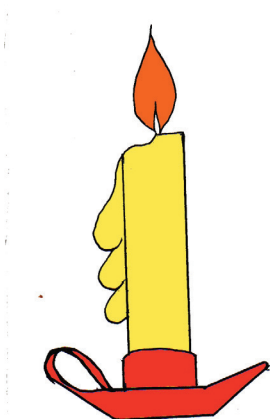

Fig 3.9 Burning candle

2. Place a few iodine flakes in a boiling tube and hold the boiling tube with a pair of tongs.
3. Heat the boiling tube gently over a non-luminous flame. Observe and record any observable changes.

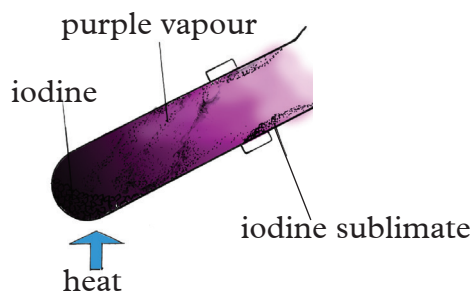

Fig 3.10 Sublimation of iodine

Quality is my choice!

Use a weighing balance that has been approved by the Rwanda Standards Board (RSB).

4. Place 5 g of naphthalene in a boiling tube and hold the tube with a pair of tongs or clamp
5. Heat as you observe the changes.

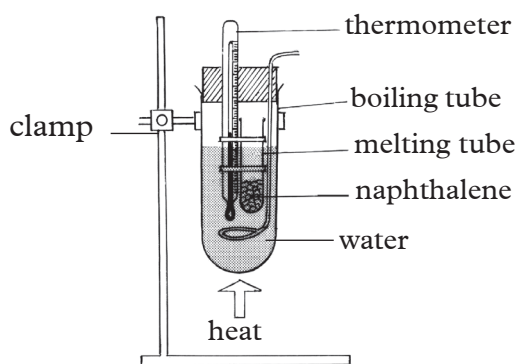

Fig 3.11 Heating naphthalene

Discussion corner!

1. (i) What observations are made when the candle is lit?
(ii) State the changes of state that take place when the candle is lit.
2. What is observed when:
 - (i) Iodine flakes are heated?
 - (ii) The product obtained is allowed to cool?
3. What is observed when:
 - (a) Naphthalene is heated
 - (b) The product is left to cool?

I have discovered that...

When the candle is lit, it burns with a luminous flame. The candle wax melts into liquid. When it flows down and cools, it solidifies. The candle wax changes from solid to liquid and from liquid back to solid.

When iodine flakes are heated, they form a purple vapour. The vapour solidifies on the cooler parts of the boiling tube to form a sublimate of pure iodine. The iodine changes directly from solid to vapour. On cooling, the vapour turns back to solid without undergoing the liquid state.

The Facts

When some solids such as **iodine** are heated, they change from solid directly to gas without passing through the liquid state. This change is called **sublimation**. On cooling, the substances condense from gas to solid. The process is known as **deposition**.

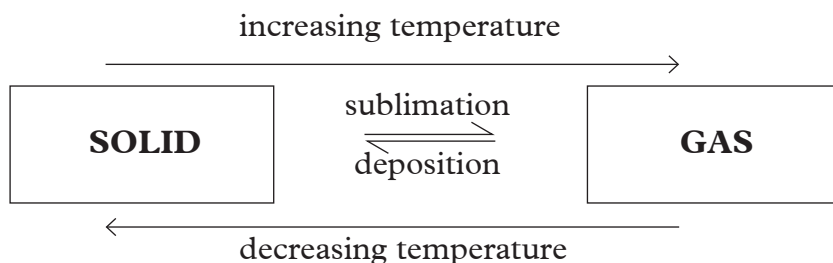

Another example of a substance that sublimates is **ammonium chloride**.

Activity 3.4

Investigating physical changes

Apparatus and reagents

Test tubes, Bunsen burner, test tube holder, candle wax, water, wooden splints, zinc (II) oxide, lead (II) oxide, beakers and boiling tube.

Procedure

1. Place few pieces of candle wax in a test tube.
2. Hold the test tube with the tube holder and heat.
3. Allow it to cool then record the observations.

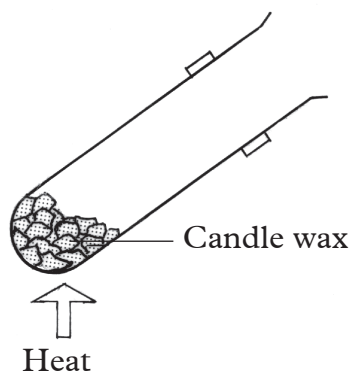

Fig 3.12 Heating candle wax

4. Heat 5 cm³ of water in a test tube until it boils. Observe the steam formed at the cooler part of the test tube. Record your observations.
5. Take a piece of wooden splint, break it into small pieces. Is there a new substance that is formed?
6. Place a spatulaful of zinc (II) oxide and lead (II) oxide in two separate test tubes.
7. Hold each with a test tube holder and heat.
8. Allow them to cool and observe their colours when cold.
9. Record your observations.

Discussion corner!

1. State the observations made when:
 - (i) Candle wax is heated then allowed to cool.
 - (ii) Liquid water is boiling.
2. Is there a new substance that is formed when a piece of wooden splint is broken down?
3. Compare the changes that take place when zinc oxide and lead (II) oxide are heated separately.

I have discovered that...

When wax is heated, it melts. On cooling, it solidifies to form the solid wax again. When liquid water is heated strongly, it boils to form steam. When the steam is cooled, it condenses to form liquid water again.

When a piece of wooden splint is broken into small pieces, it does not change to a new substance. Only the shape changes. When zinc oxide is heated, it turns into a yellow powder. On cooling, it turns back to a white powder.

All these changes are reversible. Thus the initial substances are obtained on cooling. All these changes are known as physical changes.

The facts

As seen from this activity, some of the characteristics of a physical change are:

1. No new substance is formed.
2. The mass of the substance does not change.
3. It is easily reversible.

Money matters!

Cooking fat should always be kept in a cool and dry place to prevent it from melting out.

Chemical changes

Activity 3.5

Investigating chemical changes

Apparatus and reagents

Test tubes, Bunsen burner, wooden splint, a piece of paper, magnesium ribbon, iron nails, water, pair of tongs.

Procedure

1. Light a wooden splint in a Bunsen burner flame.
2. Allow it to burn for some time.
3. Compare the product formed with the initial splint. Are they the same?

4. Burn a piece of paper to form ash.
5. Compare the product with the initial paper. Is it possible to get back the paper from the ash?
6. Using the pair of tongs, heat a piece of magnesium ribbon on a Bunsen burner flame. Allow the magnesium to burn.
Caution! Burning magnesium produces intense light that can cause temporary loss of sight. Do not look directly at the light source.
7. Collect the product and compare it to the initial magnesium ribbon.
8. Place few iron nails in a test tube containing water.
9. Keep it in an open place for one week. What do you observe?
10. Explain your observation in (9) above.

Discussion corner!

1. (a) State the observations made when the following substances are burnt.
(i) Wooden splint (ii) Piece of paper (iii) Magnesium ribbon
(b) How are the products formed in (a) above different from with the initial substances?
(c) Are there new substances that are formed?
(d) Why are those changes considered to be chemical changes?
2. Explain what happens when iron nails rust.

I have discovered that...

*When a wooden splint and paper are burnt, they form **ash**. The properties of ash are different from those of wood and paper. It is not possible to convert ash back into wooden splint or paper. Ash is a completely new substance. Thus the initial substances cannot be obtained on cooling. When magnesium is burnt in air, it produces a **brilliant white flame** and **ash**. Energy is given out in form of heat and light.*

After one week, a red brown coating forms on the nails.

*Rusting is a process in which iron combines with oxygen and moisture to form **rust**. Rust is a red-brown solid. It is impossible to convert rusted nails back to the clean ones.*

Money matters!

It is advisable to paint iron sheets to avoid regular expenses of replacing them when they rust.

The Facts

When wood is burnt, it changes to ash. We cannot get back wood from the ash. This reaction is thus **irreversible**. Similarly, when magnesium is burnt in air, it

forms powder. It is not possible also to get back the magnesium ribbon from the powder. The white powder formed is called **magnesium oxide**. It is as a result of combining magnesium with oxygen in air.

All these processes are well irreversible. They are therefore called **permanent changes**. Permanent changes are chemical changes.

Some of the characteristics of chemical changes include:

1. New substances are formed.
2. It is difficult to change the new substance back into the original substance. (irreversible).

Self evaluation test 3.2

1. Cooking fat should be stored in a cool dry place. What is the importance of this precaution?
2. State whether the following are physical or chemical changes.
 - (i) Burning a match stick into ash.
 - (ii) Freezing water to make an ice cube.
 - (iii) Explosion of a bomb.
3.
 - (i) Zinc oxide changes to _____ colour on heating and _____ colour on cooling. It undergoes a _____ change.
 - (ii) Iodine changes to _____ on heating and _____ on cooling. It undergoes _____ change.
4. State whether the following statements are **true** or **false**.
 - (a) Burning wood is a chemical change.
 - (b) Drying a shirt in the sun is a chemical change.
 - (c) Dissolving sugar in tea is a physical change.
 - (d) Cooking meat is a chemical change.

3.4 Kinetic theory of matter

Activity 3.6

To investigate the movement of particles.

1. Get some marbles and a plastic bottle with a cap.
2. Put a few marbles for example 5 in the bottle then close the cap.
3. Agitate the marbles by shaking the bottle. What do you observe?
4. Fill the bottle half way with marbles and shake the bottle once more.
5. Compare how the marbles move with the first instance.
6. Now, fill the bottle completely with marbles, close the cap and try shaking the bottle. Do the marbles move?

7. Explain your observation in (6) above.
8. Compare the three scenarios to the arrangement of particles in solids, liquids and gases.
9. Discuss the results of the experiment in your group and write a summary report.

I have discovered that...

The fewer the marbles are in the bottle, the more they move when the bottle is shaken. When the bottle is full, the marbles hardly move.

The facts

Matter consists of particles arranged in a certain way. This arrangement varies from one state of matter to another. The arrangement and movement of particles in solids, liquids and gases is explained by the **Kinetic theory of matter**. The word kinetic is derived from the Greek word '**Kineo**' which implies 'motion'.

The kinetic theory therefore explains:

- how particles that make up matter are packed in solids, liquids and gases
- the movement of these particles.
- the attractive forces between the particles and the effect of temperature on them.

According to the Kinetic theory, particles in matter are always in constant motion. For this reason, they possess **kinetic energy**. Kinetic theory of matter can be used to explain the properties of the various states of matter. The theory also explains what happens during change of state.

Packing of particles in terms of kinetic theory

Particles of a **solid** are closely packed. They are held in fixed positions by strong **interparticle forces** of attraction. They therefore vibrate but they do not move from one place to another. It is for this reason that solids have a fixed shape.

In a **liquid**, particles are free to move randomly but tend to stick together. This is because they have **moderate forces of attraction** between them. They are hence less closely packed as compared to solid particles.

The particles of a **gas** have weaker forces of attraction between them. This is why they are very far apart. They are therefore free to move randomly in any direction. For this reason, a gas occupies the entire space of a container and so a gas has no definite shape.

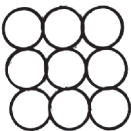
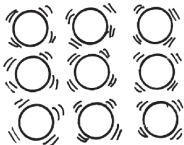
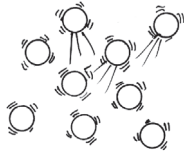
 <p>Particle arrangement in solids</p>	 <p>Particle arrangement in liquids</p>	 <p>Particle arrangement in gases</p>
---	--	--

3.5 Change of state and kinetic theory

Discussion corner!

In pairs discuss the following.

1. What can you do to convert solid ice to water?
2. What is required for one to convert water into steam?
3. Give the names of the processes that take place in (1) and (2) above?
4. What is done to reverse the processes you have mentioned in (3) above?
5. Give the names of the reverse processes by which steam is converted to water and water to solid ice?

I have discovered that...

The conversion of solid ice to water involves heating and the process is called melting. Conversion of water to steam also involves heating and is called evaporation. However, reversing these two processes requires cooling. The process by which steam is converted to water is called condensation while the conversion of water to solid ice is called freezing.

The facts

The various processes that lead to change of state include:

- (a) Melting
- (b) Evaporation
- (c) Condensation
- (d) Freezing

(a) Melting

When a solid is heated, the kinetic energy of the particles increases and they vibrate more vigorously within their fixed positions. Further heating weakens the forces of attraction between the particles. The solid thus changes to liquid. This is the melting process. The temperature at which melting occurs is known as the **melting point**.

(b) Evaporation

When a liquid is heated the particles gain more kinetic energy and the particles

start to move more rapidly. When the liquid gets hot enough the forces of attraction joining the fast moving particles at the surface are broken detaching them from the other particles. The surface particles thus escape into the air. This process is known as **evaporation**.

The liquid then changes into gaseous state. The temperature at which evaporation takes place is called the **boiling point**.

(c) Condensation

When the gas is cooled, the kinetic energy of its particles decreases. The movement of the particles slows down and they come close together. At this point the attractive forces between the particles become sufficient to hold them together. The gas then becomes a **liquid**. This process is called **condensation**.

(d) Freezing

Further decrease in temperature, makes the liquid particles to slow down their movement further. The particles come closer together and the forces of attraction between them increase. They hence vibrate within fixed positions. The particles are not free to move from one place to another. A **solid** is hence formed. This process is called **freezing**.

Self evaluation test 3.3

1. What name do we give to the following processes:
 - a) Change of solids to liquids
 - b) Change of liquids to solids.
2. Draw a diagrammatic representation of the arrangement of particles in solids, liquids and gases.
3. The following graph shows the changes that occur when a solid is heated until boiling starts. Study it and answer the question that follow.

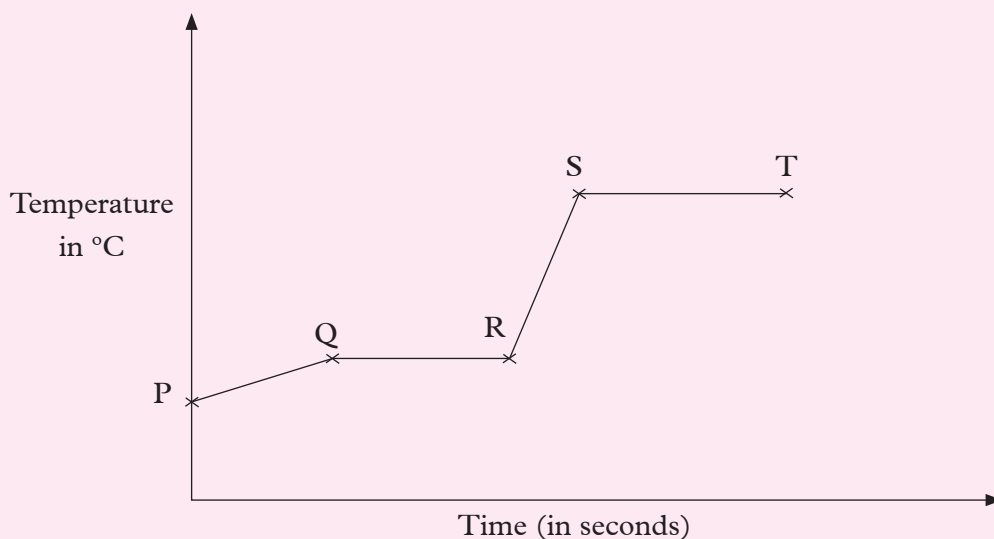

Explain what happens in regions:

- (i) P Q (ii) Q R (iii) R S (iv) S T

4. State whether the changes that occur after the following activities are physical or chemical changes. Give a reason for each case.

- (i) Place unripe bananas in a paper bag and keep them for 10 days. Observe the changes on the tenth day. Compare the unripe banana with the product you get after 10 days.
- (iii) Place some glucose in warm water and add 3 g of yeast. Leave the mixture in a warm place (30°C) for three days. Comment on the smell produced by the product.

Diffusion

Discussion corner!

On June 13 2015, at least five people died and 100 others were hospitalised in an area in the Northern Indian state of Punjab. Several residents of the area complained of breathing problems.

This was after a tanker carrying ammonia gas got stuck under a bridge resulting in the gas leak. What do you think happened to the residents?

I have discovered that...

The residents might have been admitted in hospitals because they inhaled the gas which was poisonous.

The Facts

Ammonia is one of the most poisonous gases known. It is lighter than air. It can hence move easily from one place to another. It is colourless. Ammonia has a pungent suffocating odour.

Discussion corner!

- (a) Do you have compost pits in your school?
(b) If you have them, where in the school compound are they located?
(c) Why do you think they are dug in such locations?
- Why do you think latrines are always built considering the direction of wind and a distance away from the main house?

I have discovered that...

Compost pits and latrines should be built a distance away from the houses because of the smell. This is to prevent discomfort to the house residents.

The main house and the latrine should be built in parallel to the usual direction of wind. Inhalation of poisonous gases and irritating smell occurs due to movement of gas particles from one place to another.

The Fact

Movement of particles of a substance from a region of high concentration to a region of low concentration is called **diffusion**.

Activity 3.7

a) Investigating diffusion

Apparatus and reagents

A beaker of water, a container of ink, a can of perfume spray.

Procedure

- (a) Add a drop of ink into the water. What do you notice?
(b) Add another drop of ink. Does the same thing happen again?
(c) What do you conclude?
- Remove the lid of the perfume can and press on top away from everyone. What do you notice after a few minutes?

Health check!

Let the students who are perfume intolerant stay away from the perfume.

I have discovered that...

When a drop of ink is placed onto a beaker of water, the ink particles spread until all the water is uniformly coloured. Also, after a few minutes of opening the perfume can, the smell of the perfume can be felt in the air.

The ink spreads in water and perfume is smelt due to the movement of particles from ink into the water and those of perfume into the air. We can hence say that the particles moved from the region where they were great in number to the region where they are fewer in number by the process of diffusion.

Activity 3.8

b) Investigating diffusion in gases

Apparatus and reagents

Long glass tube, concentrated ammonia solution, concentrated hydrochloric acid, cotton wool, tongs, clamp stand.

Procedure

1. Clamp a long glass tube horizontally as shown in figure 3.12
2. Soak two pieces of cotton wool, one piece in concentrated ammonia solution and the other in concentrated hydrochloric acid separately (**do not** allow the soaked pieces to come close to one another).

Caution! Ammonia and hydrogen chloride gases are poisonous. Always waft gas towards your nose if you have to smell them.

3. Quickly insert the soaked cotton wool pieces simultaneously at the opposite ends of the long glass tube.

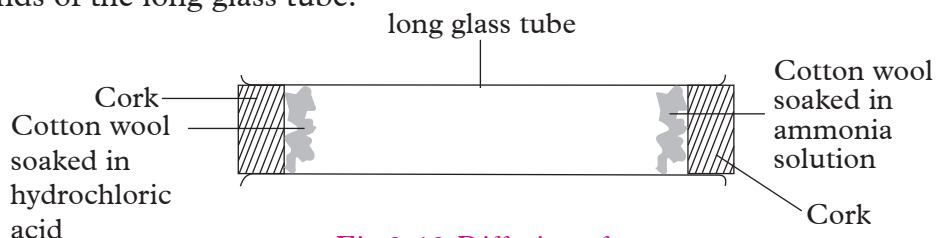

Fig 3.13 Diffusion of gases

4. Carefully observe what happens in the glass tube.
5. Measure the distance from both ends of the glass tube to the position where a patch is seen.

Discussion corner!

1. What observations are made in the glass tube?
2. At what distance from both ends of the long glass tube are the observations made?
3. Explain the observations made in the tube.

I have discovered that...

The cotton wool soaked in concentrated ammonia solution gives out **ammonia gas** whereas the cotton wool soaked in concentrated hydrochloric acid gives out **hydrogen chloride gas**. Ammonia and hydrogen chloride gases diffuse in the long glass tube. When the two gases meet, they react to form dense white fumes of **ammonium chloride** after about 5 minutes. The ammonium chloride is seen as a white ring.

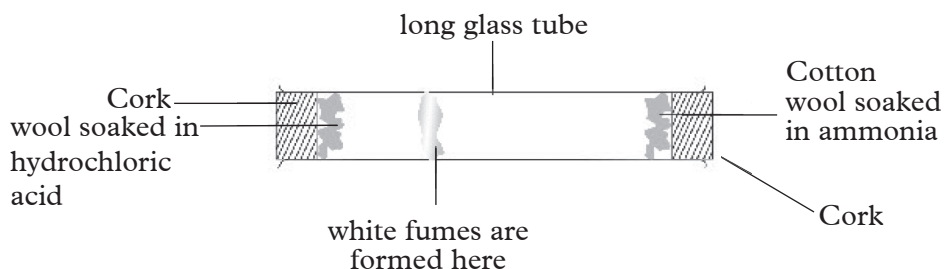

Fig 3.14 Formation of ammonium chloride

The white ring is formed closer to the end with cotton wool soaked in concentrated hydrochloric acid. Ammonia gas has less dense particles. Its particles therefore, moves faster than hydrogen chloride gas particles.

Diffusion is affected by several factors namely; temperature, concentration gradient, surface area and density of the particles. Diffusion occurs faster at higher temperatures than at lower temperatures. A gas with low density diffuses faster than that with high density. Diffusion does not take place in solids.

Brownian motion

Discussion corner!

1. What would happen if you hit a heap of marbles with a single marble from above?
2. What about if you placed marbles in a closed container and shook the container?
3. In either case, what kind of motion will the marbles make?

I have discovered that...

When a heap of marbles are hit from above, they scatter in all directions. Again when the container having marbles is shaken, the marbles move about hitting all sides of the container.

The facts

Brownian motion is the random movement of particles suspended in a fluid. This is as a result of the movement of the particles from their collision with the quick moving particles in the fluid.

This phenomenon is named after **Robert Brown** an English Botanist who discovered it. In 1827, while examining grains of pollen of a plant suspended in water under a microscope, Brown observed minute particles ejected from the pollen grains executing a continuous zigzag motion. This kind of movement is what is known as **Brownian motion**.

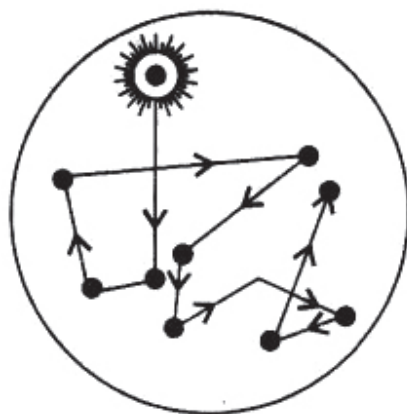

Fig 3.15 Brownian motion

Self evaluation 3.4

1. You are provided with the following: *potassium permanganate, glass tube, beaker, spatula and water*. Explain how you would demonstrate diffusion.
2. Just like animals, plants also need certain ions to be able to grow. Explain how they obtain these ions from the soil.
3. State whether this statement is true or false:
Diffusion is slower in air than it is in liquids.
4. Explain your answer in (3) above.
5. A senior one student placed 200 cm^3 of water in a 500 cm^3 glass beaker. She then crushed a piece of chalk into fine powder and placed them in the water. She stirred and heated the water to boiling as she observed. What was she trying to find out?

Remember the facts ...

- Matter is anything that occupies volume and has mass.
- The three states of matter are: gas, liquid and solid.
- Matter can undergo physical or chemical change.
- Melting is the process by which a solid is converted to a liquid at constant temperature. The reverse of melting is freezing.
- Vaporisation is the process by which a liquid changes to vapour. The reverse of vaporisation is **condensation**.
- A physical change is one where no new substance is formed while a chemical change is when a new substance is formed.
- Kinetic theory of matter states that matter is composed of many small particles that are in constant motion.
- Brownian motion is the random movement of particles suspended in a fluid.

Test Your Competence 3

1. State whether the following statements are **true** or **false**.
 - (a) The particles of a liquid are attracted to one another, but cannot move past each other.
 - (b) The atoms of a solid are very far apart and vibrate in fixed positions.
 - (c) Heating a gas completely stops all of its particles from motion.
 - (d) Air has mass.
2. When a thermometer is placed in warm water, the mercury inside moves up. This is mainly because _____.
 - A. the mercury is thin.
 - B. the particles of mercury move faster and get a little further apart
 - C. hot mercury is lighter
 - D. the glass of the thermometer gets hot.
3. The following figure shows a metal ball and a ring specially made so that at room temperature the ball just fits through the ring. However, when the ball is heated, it gets stuck and cannot fit through anymore. It gets a little bigger.

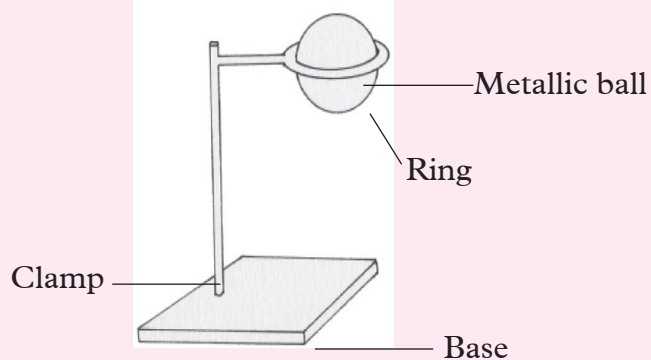

Explain how the motion and attractions of the atoms in the metal ball cause it to get slightly larger when heated.

4. Food colouring spreads out faster in hot water than it does in cold water. This is mainly because_____.
 - A. the water molecules in hot water move more quickly.
 - B. the molecules in hot water are larger.
 - C. the food colouring molecules are small.
 - D. hot water is less dense.
5. To describe a gas, you would say_____.
 - A. the particles are very attracted to each other.
 - B. the particles are not very attracted to each other.
 - C. the particles are very close together like a liquid.
 - D. the particles of a gas are farther apart than the particles in a liquid or solid.
6. Sometimes, especially on hot days, a metallic door, that opens and closes easily during cooler months, will be hard to open and close. Why is the door hard to open and close on hot days?

What is a mixture? What about a pure substance? How can you know that something is a mixture and not a pure substance?

Look fig 4.1. Can you identify mixtures in A and B? What about pure substances?

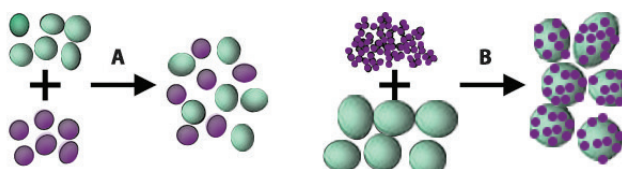

Fig 4.1 Mixtures

Key unit competency

After studying this unit I should be able to separate mixtures and determine their composition.

Unit outline

4.1 Pure substances

4.2 Mixtures

4.3 Separation of mixtures and their application

Activity 4.1

- Put some salt and sugar in separate containers.
- Taste each one of them. Try to recognize the tastes.
- Now, mix the sugar and salt in one container. Stir thoroughly using a spoon.
- Taste the mixture with your tongue.
 - How is the taste?
 - Compare it with the previous tastes.
- Now try separating the sugar from salt.
 - Is it possible?
 - If it were a mixture of maize and bean seeds, would you be able to separate them?
 - What does this tell you about mixtures?
 - What about pure substances?

4.1 Pure substances

Many substances around us are mixtures. Examples of mixtures are air, tap water, and milk. Can you name other mixtures? In everyday life, we often need to separate mixtures to obtain pure substances. This applies in cases where only pure substances are required.

Discussion corner!

1. (a) What is to be pure?
(b) When they say someone lived a pure life, what does this mean?
2. Is pure the same as clean?
3. Is table salt a mixture or a pure substance?
4. Suppose you go home from school and found out that somebody added some maize grains and water to flour in a pan, yet you need only flour. How would you obtain your flour back?
5. If you accidentally added salt to water in a cup thinking that it was sugar, how would you obtain the salt back?

I have discovered that...

We always use the word pure to mean something that is not contaminated. Just like it is always hard to conclude that a person was pure, it is also difficult to tell whether a substance is pure. For example water might be clear and clean but not necessarily pure. Yet still, table salt is a mixture but one would think it is a pure substance. What does this tell you about pure substances?

Because I need pure flour, I will remove maize grains by the use of a sieve. I would then dry the flour to evaporate the moisture. Obtaining salt from water requires a process called evaporation.

Health check!

Always add enough salt to food to avoid cases of goitre. Consuming too much salt can cause high blood pressure.

The Facts

A pure substance is one that possesses identical components.

Properties of pure substances

1. Pure substances have the same composition that is, they are composed of only one type of particles.
2. Pure substances melt and boil at definite temperatures.

4.2 Mixtures

Activity 4.2

Study questions

1. You are provided with a cup of tea and a dish of sugar. Add a spoonful of sugar to the tea and do not stir.

- (a) How does the tea taste? (b) Why do you think it tastes that way?
2. Now stir the tea and taste it again.
- (a) How does it taste? (b) Why do you think it tastes that way?

I have discovered that...

Well-stirred tea tastes sweeter than the unstirred tea.

Stiring tea helps to dissolve sugar evenly within the hot water. However, in the unstirred tea, sugar tends to settle at the bottom of the cup. This leaves the upper part of the tea without sugar.

Health check!

Avoid excessive consumption of sugar, it is harmful to your health.

The Facts

A mixture is a substance whose components can be separated by physical means. Examples are salt and water, maize and beans.

There are two types of mixtures; homogeneous and heterogeneous mixtures.

(i) Homogeneous mixture

It is a composition of two or more substances whose components distribute uniformly into each other. Examples of homogeneous mixtures include diluted juice, salt solution and well stirred tea.

A homogenous mixture can be of a liquid-liquid mixture, a liquid-solid mixture, a gas-gas mixture or a solid-solid mixture. A homogenous mixture made up of a liquid-solid mixture is referred to as a **solution**. The solid substance that dissolves is called a **solute** while the liquid in which the solute dissolves is called a **solvent**. A solution is therefore a homogenous mixture formed when a solute completely dissolves in a solvent.

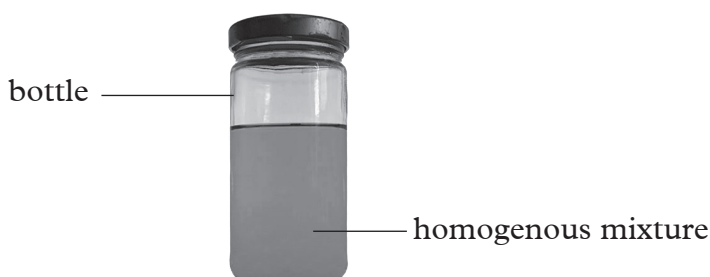

Fig 4.2. A homogenous mixture in a bottle

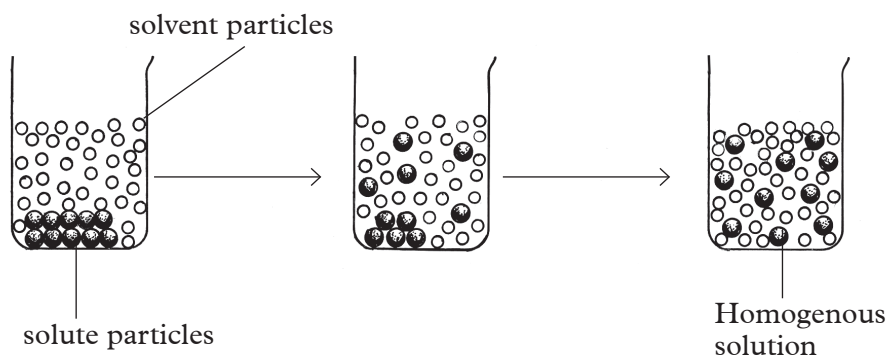

Fig 4.3: Dissolving a solid in a solvent

Water is considered a **universal solvent**. It dissolves many solutes.

(ii) Heterogeneous mixture

This is a composition whose components are unevenly distributed into each other. Examples of heterogeneous mixtures are sand and water mixture and the case of our not unstirred tea. A heterogeneous mixture can be of a liquid-liquid, liquid-solid, gas-liquid and gas-solid mixture.

No	Phase of matter	Name of mixture	Example
1	Liquid-liquid	Emulsion	Oil in water
2	Solid-liquid	Suspension	Muddy water
3	Gas-liquid	Aerosol	Fizzy drinks
4	Gas-solid	Smoke	Smog

Self evaluation test 4.1

- You are provided with a sample of salt and a plate of maize put together with beans. Answer the following questions.
 - What is the general term you can use to describe such a composition?
 - What differences can you notice between the two samples?
 - Why is common salt referred to as iodised salt?

4.3 Methods of separating mixtures

Discussion corner!

Study questions

- Where do you obtain drinking water while at home?
 - How do you know that the water is safe for drinking?
 - Why must we ensure that the water we drink is free of contaminants?
 - What do you do to ensure that the water is safe for drinking?
- You have poured some water in a basin, left it in the sunlight to warm for a while but before you take a shower, sand suddenly blows over it. How will you ensure that the water is clean again before taking the shower?

I have discovered that...

Drinking water can only be said to be safe if it is free of contaminants. Such contaminants include dust and disease causing microorganisms. They need to be separated by certain methods.

Dust can be removed from water in a basin by allowing the dust to settle at the bottom of the basin. The water is then carefully poured into in a different container leaving out the mud.

The Facts

Separation of materials is important in our everyday life. This is because sometimes we can only get the desired results when using the materials in their non-combined states.

Methods used to separate mixtures depend on the physical properties of the components. Such properties include solubility, density, boiling point and miscibility. Some of the methods of separating mixtures include:

- Manual sorting
- Filtration
- Decantation
- Simple and fractional distillation
- Paper chromatography
- Magnetic separation
- Centrifugation
- Crystallisation
- Evaporation
- Sublimation

(a) Filtration

Discussion corner!

- While at home how do you normally prepare tea?
- Do you use tea leaves?
- How do you ensure that the tea does not have tea leaves before serving?

I have discovered that...

After preparing tea we always use a strainer to remove the undissolved tea leaves. The strainer traps large tea leaves particles but allows liquid components to pass through it.

The Facts

Filtration is the most commonly used method in our everyday life. The filtering apparatus depends on the size of the particles to be obtained.

Activity 4.3

Separation of soil and water by filtration

Apparatus and reagents

Beaker, conical flasks, filter paper and funnel, soil and water mixture

Procedure

1. Fold a filter paper to form a quadrant, and then open it up into a hollow cone.

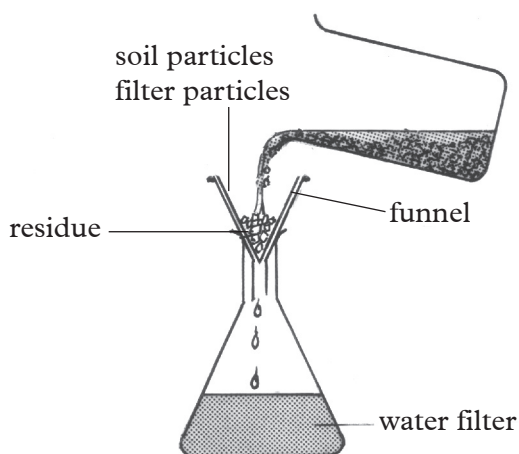

4.4: Filtration

2. Wet the paper to make it stick on the funnel.
3. Place the funnel on the conical flask.
4. Stir the mixture of soil and water and pour it into the funnel fitted with the filter paper.

Discussion corner!

1. Describe the contents left on the filter paper and those in on the conical flask?
2. What name do we give to the content on the filter paper and those in the conical flask?

I have discovered that...

Wet filter paper sticks on the funnel. When the mixture is added, it acts as a fine sieve allowing the liquid to pass through but retaining the solid particles.

The Facts

After filtration, the liquid which passes through the filter paper is called the **filtrate** while the solid that remains on it is called the **residue**.

(b) Decantation

Discussion corner!

Suppose you mistakenly added kerosene to water in a beaker thinking they are one kind of substance.

- Explain how you would separate kerosene from water.
- Is the method you have used convenient?
- Is there a special apparatus that can be used to separate the two components?

I have discovered that...

Kerosene and water do not mix. Kerosene settles on top of water and can easily be poured off. By carefully tilting the beaker containing the mixture, you can pour paraffin into another beaker hence separating the two liquids. However, the separated kerosene may still have some water in it.

Money matters!

Cut off unnecessary expenses by applying decantation in case two immiscible liquids come together.

Activity 4.4

Separating a mixture of sand and water by decantation

Apparatus and reagents

Two beakers, sand and water.

Procedure

- Place some sand in a beaker.
- Add water and stir.
- Allow the sand to settle at the bottom of the beaker. Carefully pour off the water to the second beaker by tilting the beaker containing water and sand.

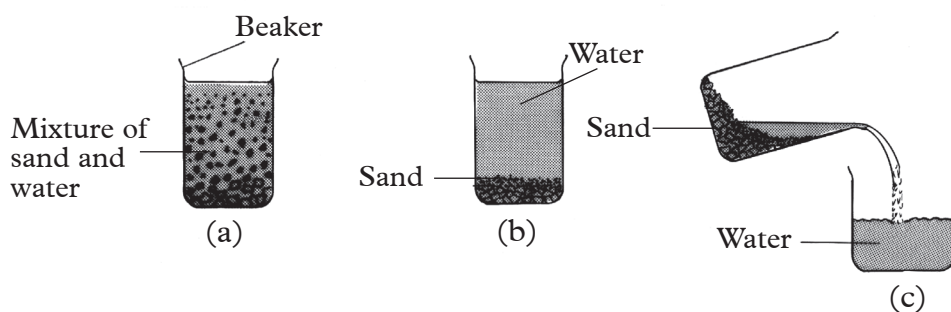

Fig 4.5 Decantation steps

I have discovered that...

When water and sand are put together, they form a heterogenous mixture. Sand settles at the bottom of the beaker and can easily be separated from the mixture.

The Facts

Decantation is used to separate liquids from insoluble solids. Using a **separating funnel** can improve the accuracy of this method. Decantation can also be used to separate liquids from immiscible liquids. Insoluble substances usually settle at the bottom or float at the top of the mixture. This way they are easily separated from the mixture.

(c) Use of a separating funnel

When a mixture of kerosene and water is separated by decantation, the kerosene obtained has some water in it. A better method of separating these two is by use of a separating funnel.

Activity 4.5

To separate kerosene and water using a separating funnel.

Materials and reagents

Separating funnel, two beakers, kerosene, water.

Procedure

1. Place the mixture of kerosene and water in a separating funnel
2. Leave the mixture for some time until there is a clear dividing line between the two liquids.

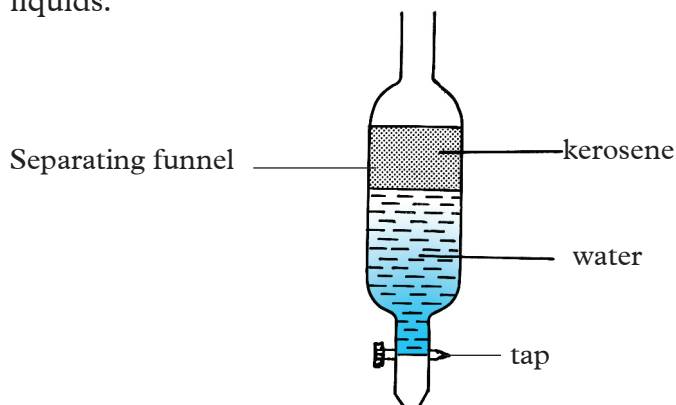

Fig. 4.6 Using a separating funnel

3. Open the tap and allow the lower layer of the mixture to run out into an empty beaker. Close the tap once this layer reaches the tap.
4. Run out a small quantity of some liquid and discard it. This might be a mixture of the two liquids.

- Open the tap again and run the top layer of the mixture into another empty beaker.
- You now have separated the two liquids.

The Facts

A mixture of water and kerosene forms two layers. The top layer is that of kerosene while the bottom one is that of water. The two liquids cannot form an homogenous mixture. They therefore are called **immiscible** liquids. Liquids that form a homogenous mixture are called **miscible** liquids. Kerosene floats on water because it is less dense than water.

What other liquids can you separate using this method?

Self evaluation test 4.2

Think of areas where filtration is applied at home. Write them down in your notebook.

(d) Simple distillation

Activity 4.6

Investigating simple distillation

Apparatus and reagents

Round bottomed flask, Bunsen burner, stand, condenser, wire gauze, clamp, pieces of porous pot, thermometer, beaker, common salt and water

Procedure

- Prepare some salt solution.
- First try to separate the components by decantation method. Are you able to separate salt from water?
- Pour the solution into the flask and add pieces of porous pot.
- Arrange the apparatus as shown in the following figure.

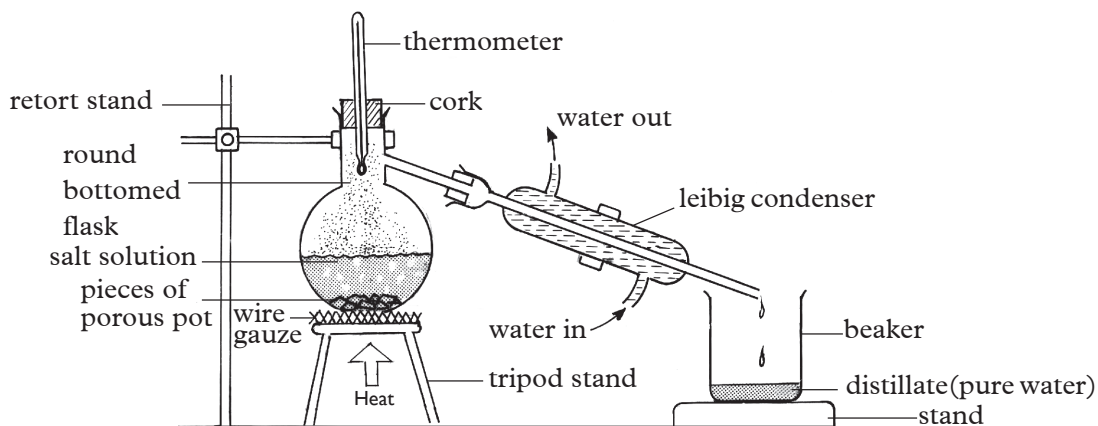

Fig 4.7 Simple distillation apparatus

Discussion corner!

1. What is the use of the thermometer and the pieces of porous pot?
2. What do you think would happen if directions of water in the condenser were reversed?
3. What is the name of the liquid collected in the beaker?

I have discovered that...

The thermometer is used to note the temperature at which the solution boils. When the solution in the flask is heated, it evaporates and steam (water vapour) can be seen rising up the flask. After some time, drops of water can be seen coming from the condenser and collecting into the beaker.

The Facts

The liquid collected in the beaker is called the **distillate**. In this case the beaker is the **receiver**. This process is called **simple distillation**. During distillation therefore, evaporation and condensation take place at the same time but in different apparatus.

Apart from separating volatile substances from involatile ones, simple distillation can also be used to separate liquids whose boiling points are at least 50°C apart.

(e) Fractional distillation

Activity 4.7

Investigating Fractional distillation

Apparatus and reagents

Round bottomed flask, condenser, fractionating column, Bunsen burner, wire gauze, glass beads, thermometer, beaker, ethanol and water

Procedure

1. Put a mixture of ethanol and water into a round-bottomed flask and arrange the apparatus as shown in the following figure.

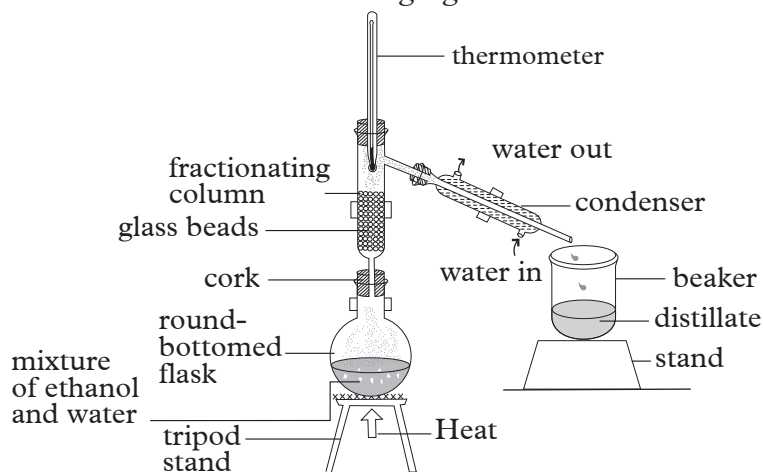

Fig. 4.8 Apparatus for fractional distillation

Discussion corner!

1. What are the functions of the glass beads in the fractionating column?
2. How would you test for the first distillate if you had a burning splint and a sample of the distillate?

I have discovered that...

Glass beads increases surface area for condensation of vapour in this experiment. If a burning splint is brought to the surface of the first distillate (ethanol), it ignites. Ethanol is flammable and has a characteristic smell.

Health check!

Ethanol is found in alcoholic beverages. Consumption of alcohol is not a healthy habit.

The Facts

When we try to separate a mixture of ethanol and water by simple distillation, the first distillate will not be pure ethanol. It will contain portions of water. An efficient method therefore would be **fractional distillation**. Ethanol has a lower boiling point than water. It thus boils and condensens first.

Fractional distillation is also used industrially to separate the components of crude oil and also those of air.

(f) Paper chromatography

Activity 4.8

Investigating chromatography

Apparatus and reagents

Beaker, filter paper, black ink, dropper, propanone and teat pipettes

Procedure

1. Place filter paper on the beaker.
2. Use a teat pipette to put a drop of black ink at the centre of the filter paper.
3. Add propane drop wise using a different pipette, waiting till each drop has stopped spreading.
4. Repeat until the outermost boundary is near the edge of the paper.
5. Leave the paper to dry and compare the bands formed with those of other pairs.

I have discovered that...

*Ink is made of several dyes as evident from the formation of several rings formed. The different dyes in the ink dissolved in propanone and spread out through the filter paper to form a series of bands. The series of bands is called a **chromatogram**.*

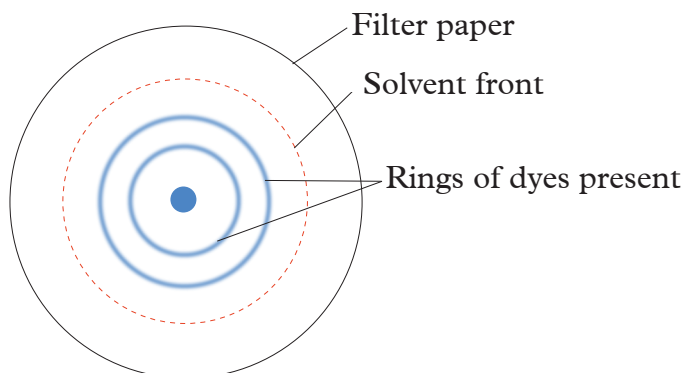

Fig 4.9. A chromatogram

The Facts

Two factors are necessary for the chromatogram to form. These are:

- (i) The dye must be soluble in the solvent used.
- (ii) The absorbent material must retain the dyes.

The degree of solubility in propanone is different for the dyes in the ink. The filter paper also retains the dyes at different rates. The dye immediately after the **solvent front** is the most soluble. It is also the least retained. The solvent front is the farthest point reached by the solvent on the chromatogram.

(g) Magnetic separation

Discussion corner!

Your younger brother plays with some nails and unfortunately he drops them in a container of cooking flour.

- (a) How would you remove the nails?
- (b) What could be the effect of feeding on foodstuff contaminated with metallic materials?

I have discovered that...

When you pass a magnet through a mixture of flour and iron nails, the nails get attracted to the magnet. This way, they are separated. Feeding on foodstuffs containing metallic substances can trigger infections.

Health check!

Consumption of food contaminated with metallic materials can lead to poisoning.

The facts

Magnetic separation is the process whereby magnetically susceptible materials are extracted from a mixture using a magnetic force.

Self evaluation test 4.3

1. An aunt of a senior one student who stays in Rubavu has been complaining of the water they fetch from the village borehole as being salty.
 - (a) What do you think is the composition of the water?
 - (b) What advice would you have given her?
2.
 - (a) Which two methods can you use to separate a mixture of salt and water?
 - (b) Which of the methods you have suggested is the most appropriate?
 - (c) Name another material that can be used in place of glass beads in simple distillation?
3. Apart from solving rape cases, in which other areas can we apply chromatography?

(h) Centrifugation

This is a process by which a centrifuge is used to separate components of a complex mixture. The centrifuge separates a heterogeneous mixture of a solid and a liquid by spinning it at a high speed. The solid precipitate settles at the bottom of the test tube and a solution called the **supernatant** is formed. Centrifugation is used in separation of urine components in hospitals.

(i) Crystallisation

Discussion corner!

1. Find out from the dictionary what a crystal is.
2. Using references materials find out the meaning of a saturated solution.

I have discovered that...

A crystal is a solid substance that is regular in shape. An example of crystal is that of table salt. A saturated solution is one that cannot dissolve any more of the solute at a given temperature. Crystals can be made from a saturated solution.

Activity 4.9

To prepare big crystals of copper (II) Sulphate

Apparatus and reagents

Beaker, copper (II) sulphate, water, glass rod.

Procedure

1. Prepare about 50 cm³ of a saturated solution of copper (II) sulphate solution using the method in activity.
2. Put the filtrate in a beaker and cover it with a filter paper pierced with a few holes.
3. Leave the content of the beaker undisturbed for 2-3 weeks.

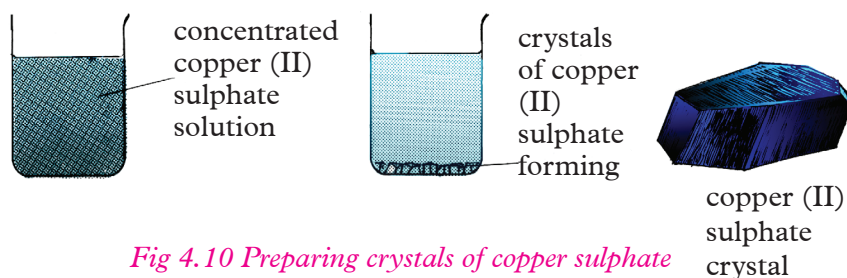

Fig 4.10 Preparing crystals of copper sulphate

Discussion corner!

What do you observe after the third week?

I have discovered that...

After the third week, solid substances with a regular shape are seen at the bottom of the beaker. Pale blue solution forms above the solid substances.

The facts

The solid substances with a regular shape are called crystals. The colour of the solution changed from deep blue in colour to pale blue due to a reduction in concentration of the solution.

(j) Evaporation

Activity 4.10

To carry out evaporation on salt solution.

Apparatus and reagents

Beaker, Bunsen burner, conical flask, filter funnel, glass rod, filter paper, wire gauze, water, sand, salt, tripod stand and evaporating dish.

Procedure

1. Place the mixture of salt and sand in a beaker half filled with water.
2. Stir with a glass rod to make salt to dissolve faster.

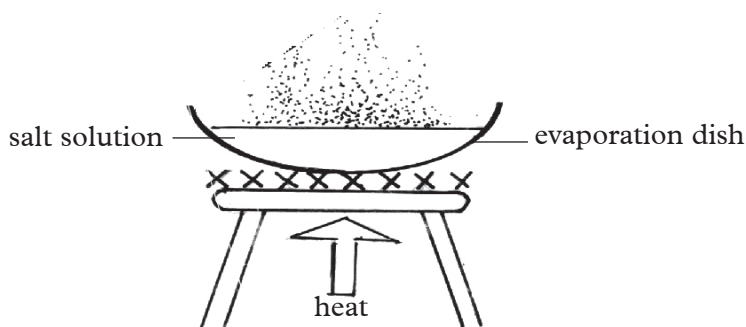

Fig. 4.11 Apparatus for carrying out Evaporation

3. Pour the mixture into a conical flask through a filter funnel fitted with a filter paper.
4. Put the filtrate into an evaporating dish and heat gently. Evaporate to dryness.

Discussion corner!

1. Name what remains in the filter paper and on the evaporating dish.
2. What are the two methods used in this activity?

I have discovered that...

When the solution starts boiling; steam (water vapour) is expelled. At the end of the experiment, solid crystals remain in the evaporating basins.

The Facts

The process of changing a liquid to gaseous form is called **evaporation**. Water in the solution therefore escapes as water vapour (steam). If this steam is well collected and condensed, water can be obtained back. The solid left in the basin is salt. When this solid is dried between filter papers crystals of the salt are obtained.

Further activity

Write a report on the findings of a similar experiment involving separation of sugar and sand mixture and present it to the class.

The report should have these parts: aim, apparatus and reagents, labelled drawing of the apparatus, procedure, results and conclusion.

(k) Sublimation

Activity 4.11

To separate ammonium chloride from sodium chloride.

Materials and reagents.

Sodium chloride salt, ammonium chloride, Bunsen burner, boiling tube, beaker

Procedure

1. Mix the sodium chloride and ammonium chloride evenly in the beaker.
2. Transfer the content of the beaker into the boiling tube.
3. Heat the mixture until there is no further change (Ensure that the boiling tube is tilted/slanting when heating)
4. Allow the boiling tube to cool while still in a slanting position.

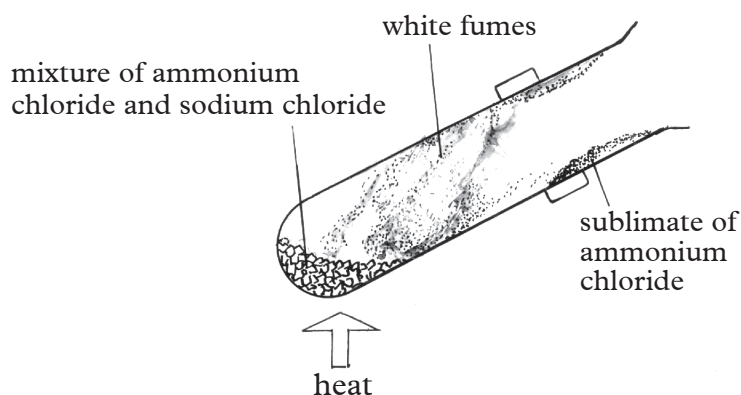

Fig 4.12: Sublimation

I have discovered that...

When the mixture is heated, white fumes are seen coming from the mixture up the boiling tube. On cooling the white fumes condense, and attach on the side of the boiling tube near its mouth.

The Facts

Ammonium chloride undergoes sublimation while sodium chloride does not. The white fumes seen are of ammonium chloride. When cooled the fumes undergoes deposition to form ammonium chloride sublimate. The solid left at the bottom of the boiling tube is sodium chloride.

Discussion corner!

1. What observation do you make when you start heating?
2. What observation do you make after cooling the boiling tube?

Percentage composition by mass and volume of a component in a mixture

Activity 4.12

1. In pairs classify the following substances as either compounds or mixtures. Sodium chloride, sugar solution, water, magnesium oxide, carbon monoxide, copper oxide, copper nitrate.
2. Identify the elements forming each of the mixtures or compound listed above in a table like one below. The first one has been done for you.

Substance	Compound or mixture	Components of the mixture or compound
Sodium chloride	Compound	Sodium and chlorine
Sugar solution		
Water		
Magnesium oxide		
Carbon monoxide		
Copper oxide		
Copper nitrate		

I have discovered that...

All these substances are compounds except sugar solution which is a mixture. The compounds making these substances are as follows:

- Sodium chloride – sodium + chlorine
- Sugar solution – sugar and water
- Water – hydrogen + oxygen
- Magnesium oxide – magnesium + oxygen
- Carbon monoxide – carbon + oxygen
- Copper oxide – copper + oxygen

The facts

From the activity above, it is clear that compounds and mixtures are made of different constituent elements. It is possible to calculate the percentage composition of constituents of a mixture or compound by mass.

Example 1

Calculate the percentage composition of nitrogen by mass in nitrogen monoxide (NO) given that N = 14, O = 16.

Solution

The total mass of the gas is $14 + 16 = 30$

Percentage composition of nitrogen can thus be given as:

$$\frac{14}{30} \times 100 = 46 \%$$

Example 2

Calculate the percentage composition of hydrogen by mass in water (H_2O) given that $\text{H} = 1$, $\text{O} = 16$

Solution

1 atom of hydrogen has a mass of 1. But water has 2 atoms of hydrogen. The mass of hydrogen is therefore $1 \times 2 = 2$.

But the total mass of $\text{H}_2\text{O} = 2 + 16 = 18$

Percentage composition of H_2 is therefore:

$$\frac{2}{18} \times 100 = 11.1\%$$

Example 3

Calculate the percentage composition of calcium by mass in calcium oxide (CaO) given that $\text{Ca} = 40$, $\text{O} = 16$

Solution

Total mass of $\text{CaO} = 40 + 16$

$= 56$

Percentage composition of calcium

$$= \frac{40}{56} \times 100$$

$= 71.4\%$

Self evaluation test 4.4

Calculate the percentage composition by mass of the element in bold in the following compounds.

1. Nitric acid (HNO_3) ($\text{H} = 1$, $\text{N} = 14$, $\text{O} = 16$)
2. Magnesium oxide (**Mg**O) ($\text{Mg} = 24$, $\text{O} = 16$)
3. Ammonium chloride (NH_4 **Cl**) ($\text{N} = 14$, $\text{H} = 1$, $\text{Cl} = 35$)

Remember the facts...

- A pure substance is one whose components cannot be separated by physical means.
- A mixture is a substance that can be separated into its components by physical means.
- A homogeneous mixture has the particles of the components evenly distributed in each other.
- A heterogeneous mixture has the particles of the components unevenly distributed into each other.
- Filtration is done using a special paper called a filter paper.
- Fractional distillation can be used to separate more than one component of a mixture.

Test Your Competence 4

1. Name some of the things that appear as pure substances but are actually mixtures.
2. Given the following substances: copper, common salt and tap water. Classify them into pure substances and mixtures.
3. Name the methods by which the following mixtures can be separated.
 - (a) Kerosene from crude oil
 - (b) Pure water from seawater
4. Suggest an appropriate method that can be used to separate cream from milk.
5. During the harvesting season, you realise that your maize grains contain a lot of maize husks. How will you separate the grains from husks?
6. If you mistakenly add salt to boiling water instead of sugar while preparing tea, what would you do to obtain your salt back?
7. Which of the following methods can be used to separate iodine from sand?
 - (a) Evaporation
 - (b) Fractional distillation
 - (c) Sublimation
 - (d) Filtration
8. Account for this statement: "Milk is a pure substance".
9. The figure below shows a chromatogram of a dye.

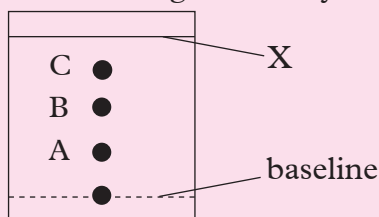

- a) Name the line labelled X.
 - b) Was the dye a mixture or a pure substance? Explain.
 - c) Name a suitable solvent that can be used to dissolve the dye for a successful separation.
 - d) Give two reasons as to why C moved the furthest distance while A moved the shortest distance.
10. Mukamutara was sent by her mother to buy a packet of salt from a kiosk. On her way back, she tripped and the packet fell down bursting open. She collected the salt together with some soil and small stones. Give a detailed procedure that she could use to obtain clean salt crystals from this mixture.
 11. The following diagram shows an arrangement of apparatus that can be used to separate water from ethanol.

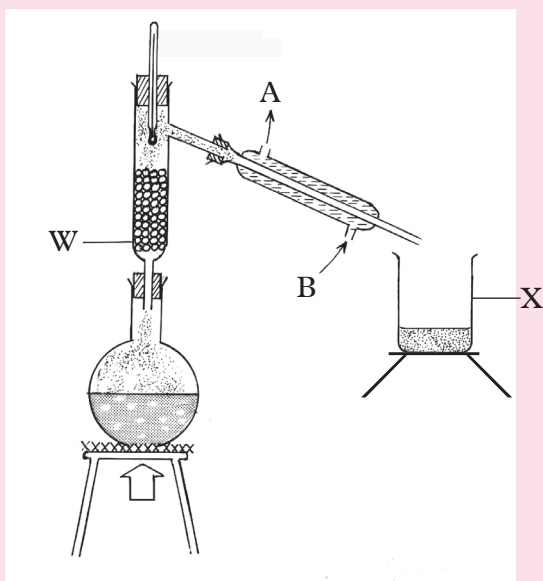

- Name the method.
- Name the apparatus labelled W.
 - What is the function of the glass beads in W?
- Name the substances represented by arrows A and B.
- What substance do you expect to collect first in X?
- Give a reason for your answer in (d) above.

12. You are given a mixture of ammonium chloride, sand and table salt. Explain how you can separate the three substances.

In order to appreciate what atoms, elements and compounds are, carry out the following activity.

Activity 5.1

1. Take a piece of paper. Note its size.
2. Tear the piece of paper into half. Note the size of the resultant papers. Which one is smaller? These pieces or the original paper?
3. Continue tearing the pieces of paper into halves until you can no longer tear them. Why do you think you are not able to tear the pieces of paper further?
4. Now, burn the pieces of paper that you teared.

Observe the product formed. What is its colour? Why is it different from the original colour of the paper?

Compare your findings in this experiment with atoms, elements and compounds. Research on the differences between the three.



Fig 5.1 Diamond ring is made of the element carbon

Key unit competency

After studying this unit, I should be able to comprehend the structure of an atom and relate valency to the chemical formulae of compounds

Unit outline

- 5.1 Definition of elements, atom and molecule
- 5.2 Symbols of chemical elements
- 5.3 Main components of an atom
- 5.4 Atomic characteristics
- 5.5 Electronic configuration
- 5.6 Elements and compounds
- 5.7 Instability of atoms
- 5.8 Chemical formulae and nomenclature

5.1 Definition of element, atom and molecule

All objects from our everyday life that we touch or see are composed of small particles called **atoms**. Atoms are very tiny and invisible. **An atom is the smallest particle into which an element can be divided without losing the properties of the element.** How can we determine the size and shape of an atom? Elements

are pure substances made up of only one kind of atom. When atoms join together, they form molecules. For example, water is made of hydrogen and oxygen atoms joined together.

Discussion corner!

1. How did you define matter in unit 3?
2. (a) What is the smallest thing that you know that occupies volume, has weight and cannot be divided any further?
(b) Why do you think it is the smallest?
3. As the secretary of a class consisting of thirty-two students, you have a single orange; all the class members need a share of the fruit:
 - (a) How will you share it with everyone equally?
 - (b) Is there a point at which the orange will be too small that you can no longer divide it?
 - (c) How small were the pieces?
 - (d) Could they be seen or touched?

I have discovered that...

*When you sub-divide an orange, it reaches a point at which further sub-division cannot take place. Although the portion is small, it still occupies volume and has weight. Hence it is considered to be **matter**.*

Just like the orange, substances can be sub-divided to the point where further division cannot take place. At this point, we call the particles atoms. Atoms are the smallest basic units of matter.

The Facts

An atom **is the smallest particle into which an element can be divided without losing the chemical properties of the element.**

Atoms are usually very small such that they cannot even be seen with the aid of a microscope.

An **element is a type of matter composed of atoms that all have the same atomic number. Atoms of the same element or different elements can combine. When they do so, they form molecules.**

5.2 Symbols of chemical elements

Discussion corner!

1. (a) Why are people given names at birth?
(b) And what do people consider when naming?
2. Why do people have different names?

3. When you go to shop, how do you know that a certain product is actually manufactured by a particular company?
4. How can I know that a product I am about to buy is of quality and safe for consumption?

I have discovered that...

When babies are born, they are given names, which are used to identify them. Some babies are named after other people. In other cases, seasons are considered. Having specific names for every person enables effective communication as it prevents confusion while referring to people. A given symbol on a product enables a consumer to know the manufacturer. A quality symbol on a product also enables us to ascertain that a product has been certified by the standards board.

The Facts

In Chemistry, elements are given certain names considering either where they were discovered or who discovered them. It is from these names that symbols are obtained. The symbols of elements are different and specific to each element. This creates orderliness when organising information about different elements.

The system of writing symbols uses letters taken from the name of the element. This could be the English or Latin name of the element.

The symbol of an element may consist of one or two letters. The first letter of a chemical symbol must always be a capital letter. The letters should not be joined. These symbols are an **international code**. This means that all over the world, they are written in the same way no matter how people spell the name of the element in their language. The symbol of an element thus remains the same in all languages.

Table 5.1 First 20 elements with their symbols

	Element	Symbol
1	Hydrogen	H
2	Helium	He
3	Lithium	Li
4	Beryllium	Be
5	Boron	B
6	Carbon	C
7	Nitrogen	N
8	Oxygen	O
9	Fluorine	F
10	Neon	Ne
11	Sodium	Na
12	Magnesium	Mg
13	Aluminium	Al

	Element	Symbol
14	Silicon	Si
15	Phosphorus	P
16	Sulphur	S
17	Chlorine	Cl
18	Argon	Ar
19	Potassium	K
20	Calcium	Ca

The following elements, symbols use two letters obtained from their **English name** as their symbols.

Table 5.2: Elements with symbols derived from their English names

Element	Symbol
Calcium	Ca
Cobalt	Co
Chlorine	Cl
Magnesium	Mg
Manganese	Mn

Below are element symbols which use one or two letters from their Latin names.

Table 5.3: Elements with symbols derived from their latin names

Element	Latin	Chemical symbol
Potassium	Kalium	K
Sodium	Natrium	Na
Iron	Ferrum	Fe
Lead	Plumbum	Pb
Silver	Argentum	Ag
Copper	Cuprum	Cu
Mercury	Hydragyrum	Hg
Gold	Aurum	Au

5.3 Main components of an atom

The components of the atom are known as sub-atomic particles. **Protons** and **neutrons** are found in a central location within an atom. This location is called the **nucleus**. **Electrons** are found outside the nucleus but within the atom.

The nucleus of an atom is positively charged due to the presence of protons which are positively charged. Neutrons, as their name indicates, are neutral, i.e they have no charge.

Electrons are negatively charged and keep on moving round the nucleus experiencing a force of attraction from the nucleus.

Electrons occupy special positions known as **levels**.

A sub-atomic particle consists of characteristic charge, mass and its symbol.

Table 5.4 Properties of sub-atomic particles

Particle and its symbol	Relative Mass	Relative Charge
Protons (p)	1	+1
Electrons (e)	1/1840	-1
Neutrons (n)	1	0

The number of protons is equal to the number of electrons. For this reason, the atom is considered **electrically neutral**.

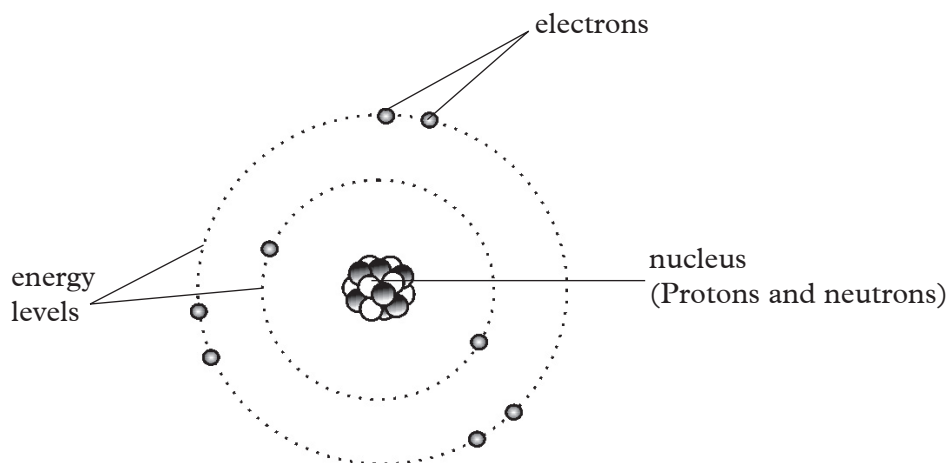

Fig 5.2 Atomic structure showing nucleus and electrons

5.4 Atomic characteristics

Discussion corner!

1. Why do people of the same family have specific names although they still share a common family name?
2. Why do you think people normally hold their family names in high regard?

I have discovered that...

Family names mean that people belong to a particular ancestry. Members of similar ancestries always have specific names that define them. Comparatively, even though atoms of the same element have the same number of protons, they can have different numbers of neutrons.

The Facts

The number of protons in the nucleus of the atom is always referred to as the **atomic number**.

The symbol for the atomic number is (**Z**).

When the total number of protons and neutrons are added we get the **mass number**.

The symbol for mass number is (**A**).

We can use the numbers on any atom to work out the number of protons, neutrons and electrons.

Using the relationship:

$$A = Z + N$$

Where **N** is the number of neutrons in an atom, we can work out the number of neutrons as follows.

Example

The mass number of sodium is 23 and the number of protons in its atom is 11. Calculate the number of neutrons in an atom of sodium.

$$\text{If } A = Z + N \text{ then } N = A - Z$$

Therefore, $N = 23 - 11 = 12$, the number of neutrons is hence 12.

The difference in number of neutrons leads to difference in mass number.

One element may have more than one type of atom based on differences in number of neutrons. Such atoms are known as **isotopes**.

Isotopes have the same chemical behaviour but slightly different physical properties.

Example:

There are two isotopes of chlorine.

- Chlorine – 37
- Chlorine – 35

With the knowledge of mass number, atomic number and the chemical symbol, an atom of an element can be represented using the symbol of the element. On the symbol, mass number is written as a superscript while the atomic number is written as a subscript. Both are written before the symbol.

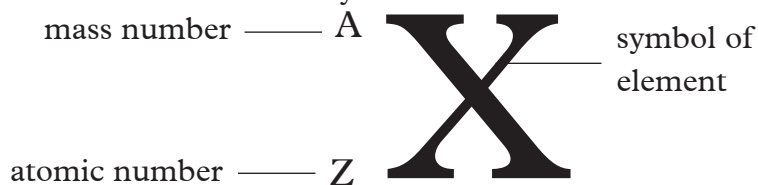

Can you think of how the symbol of sodium atom would be if represented this way?

5.5 Electronic configuration

The Facts

Energy level is a possible location around the nucleus of an atom where electrons are found. They are represented as $n = 1, 2, 3$ etc as shown in the following figure. There are 7 possible energy levels in atoms.

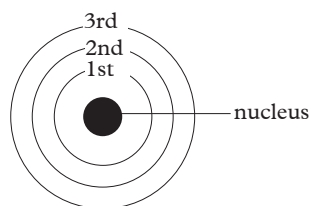

Fig 5.3. Energy Levels

The first energy level (**labelled 1**) can hold up to only two electrons.

The second energy level (**labelled 2**) can hold a maximum of eight electrons. This energy level is filled after the first energy level and before the third level.

The third energy level (**labelled 3**) can hold a maximum of 18 electrons, however when 8 electrons are in the third level there is a degree of stability; and other electrons are added to the fourth energy level. Electrons must first fill the first energy level before they start occupying the second energy level.

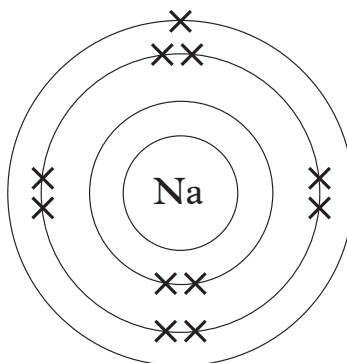

Fig 5.4 Shell model for sodium (Na)

Number of protons=11, number of electrons=11

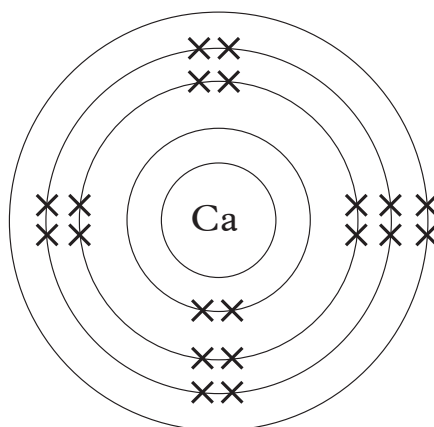
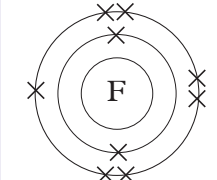
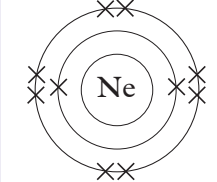
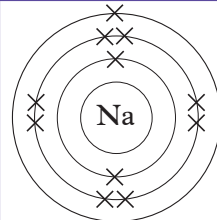
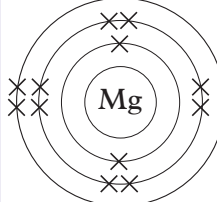
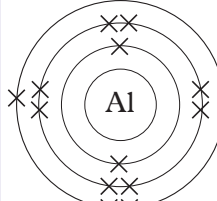
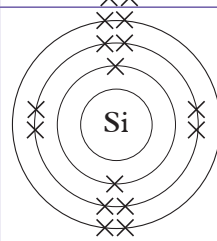
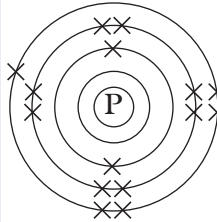

Fig 5.5 Shell model for calcium (Ca)

Number of protons = 20, number of electrons = 20

Table 5.5: Atomic number, mass numbers, sub-atomic particles and electronic configuration of the first 20 elements in the Periodic Table

Element and symbols	Atomic number (z)	Mass number (A)	Sub-atomic particles			Electronic structure	Lewi's electronic arrangement
			p	n	e ⁻		
Hydrogen (H)	1	1	1	0	1	1	
Helium (He)	2	4	2	2	2	2	
Lithium (Li)	3	7	3	4	3	2.1	
Beryllium (Be)	4	9	4	5	4	2.2	
Boron (B)	5	11	5	6	5	2.3	
Carbon (C)	6	12	6	6	6	2.4	
Nitrogen (N)	7	14	7	7	7	2.5	
Oxygen (O)	8	16	8	8	8	2.6	

Element and symbols	Atomic number (z)	Mass number (A)	Sub-atomic particles			Electronic structure	Lewis electronic arrangement
			p	n	e ⁻		
Fluorine (F)	9	19	9	10	9	2.7	
Neon (Ne)	10	20	10	10	10	2.8	
Sodium (Na)	11	23	11	12	11	2.8.1	
Magnesium (Mg)	12	24	12	12	12	2.8.2	
Aluminium (Al)	13	27	13	14	13	2.8.3	
Silicon (Si)	14	28	14	14	14	2.8.4	
Phosphorus (P)	15	31	15	16	15	2.8.5	

Element and symbols	Atomic number (z)	Mass number (A)	Sub-atomic particles			Electronic structure	Lewis electronic arrangement
			p	n	e ⁻		
Sulphur (S)	16	32	16	16	16	2.8.6	
Chlorine (Cl)	17	35	17	18	17	2.8.7	
Argon (Ar)	18	40	18	22	18	2.8.8	
Potassium (K)	19	39	18	20	19	2.8.8.1	
Calcium (Ca)	20	40	20	20	20	2.8.8.2	

Elements and compounds

Discussion corner!

1. What makes up a word in a language?
2. Are those things you named in 1 different or the same?
3. How can the visually impaired students read their notes and study?
4. Can a language exist without words?

I have discovered that...

*Alphabetical letters can make up words in a language if carefully arranged.
In English language, we have twenty-six letters, but we can make thousands of words from them.*

Visually impaired students use braille; a series of pattern arrangements that corresponds to letters of the alphabetic letters. Clearly, words are the building blocks of a language.

In Chemistry, if you want to build a molecule, you need atoms of different elements. In this case alphabetic letters are the elements while the words are the molecules.

Each element is a little bit different from the rest.

We have about 118 elements in Chemistry. When you combine them differently, you can make millions of different compounds.

The Facts

An **element** is a type of matter composed of atoms that all have the same atomic number. When two or more elements combine a compound is formed. A **compound** is therefore defined as a pure substance made up of two or more elements chemically combined. A **molecule** is the smallest particle of a substance that retains the chemical and physical properties of the substance and is composed of two or more atoms.

Self evaluation test 5.1

1. Given the following substances; common salt, water, nails, sand and kerosene. Classify them into elements and compounds.
2. A student is sent by the teacher to the laboratory to collect samples of cobalt and copper from the laboratory storage room. On reaching the shelves, she finds that all the metals are labelled using their symbols. How can she recognise the two metals before collection?
3. While at home, you come across lead acid battery containing this symbol Pb.
 - (a) What is the meaning of this symbol?
 - (b) Why should this be a matter of concern to you?
 - (c) Suggest the most appropriate ways of disposing of used lead acid batteries.

5.6 Instability of atoms

Discussion corner!

1. Consider the places where you come from:
 - (a) Are there people who are starving, have no clothes and proper housing to live in?
2. In the same places, do you have families who throw away extra food, have very many clothes that they no longer need? Do they really know they have

- neighbours who have none?
3. What are the views of those who starve on those who squander their extra possessions?
 4. What do you think the family with extra food and clothes should do?
 5. What should the starving do?
 6. What do you think would be the mood in that place if people shared out the extra materials they have with those who do not have?
 7. Why do you think sharing our possessions with others is important?

I have discovered that...

When people live by sharing the extra materials they have with those that do not have, stable and happy communities are built. However no one should be forced to share their property. They should only be taught the importance of generosity. This in turn helps to foster unity. Unity is important for prosperity.

Fairness is my other name!

Always be generous enough to share the extra possessions you have.

Just like people will most likely share their property with others, atoms too, always tend to lose or gain extra electrons so as to be stable.

The Facts

Atoms are electrically neutral; the number of protons i.e positive charges in the nucleus is equal to the number of electrons i.e negative charges in the energy levels. However, most atoms with the exception of group VIII elements do not possess stable electron configuration i.e. **noble gas electronic configuration**. An atom is said to be stable when its outermost energy level has the maximum number of electrons it can hold. Otherwise, it is said to be unstable. An unstable atom can gain stability by either gaining or losing one or more electrons. When an atom gains electron(s) to gain stability it becomes negatively charged. On the other hand, when an atom loses electron(s) to be stable it becomes positively charged. A positively charged ion is called a **cation** while a negatively charged ion is called an **anion**. **Noble gas** electronic configuration implies that the outermost energy level has the maximum number of electrons that it can accommodate.

What determines whether an atom will gain or lose an electron to gain stability?

This is determined by the number of electron in the outermost energy level of the atom. Consider for example the atom of sodium and that of chlorine.

The electron configuration of sodium is 2.8.1. Sodium can only be stable if the outermost energy level has 8 electrons. Less energy will be required to lose one electron than to gain 7 electrons. The stable ion of sodium will thus have the electron arrangement of 2.8. On the other hand, chlorine has an electron arrangement of

2.8.7. Chlorine will require less energy to gain one electron and be stable than lose 7 electrons. The stable ion of chlorine will thus have an electron arrangement of 2.8.8.

Examples

(a) Formation of a sodium cation.

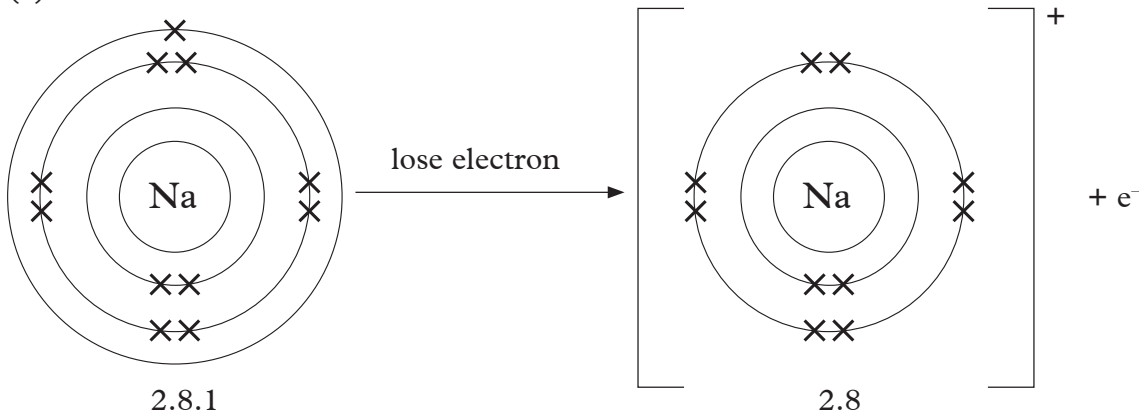

Fig 5.6 Formation of Sodium Ion (Na^+)

(b) Formation of a chloride anion

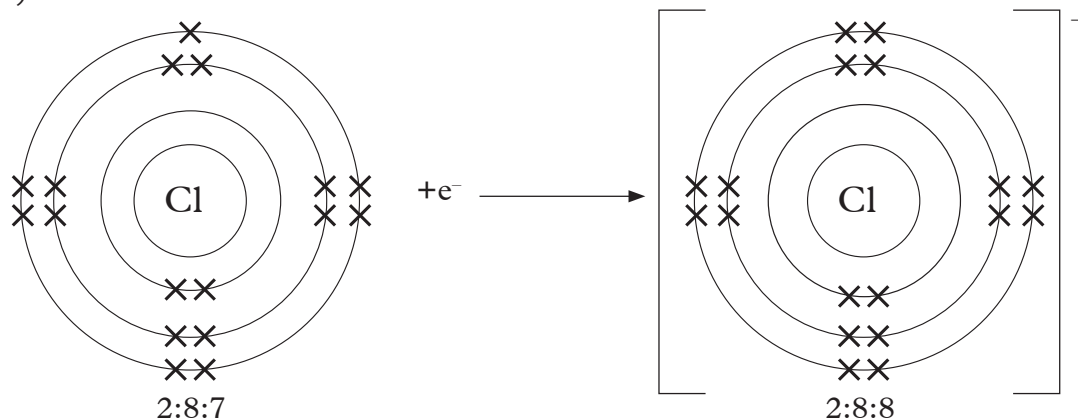

Fig 5.7 Formation of Chloride Ion (Cl^-)

Self evaluation test 5.2

1. What do the words duplet and octet imply?
2. I am an atom. My name is Magnesium. I have two electrons in the outermost energy level.
 - (a) Do you think I am stable?
 - (b) If not, what can I do in order to attain stability?
3. What do you think of aluminium atom in terms of stability? How many electrons must it gain or lose to be stable?
4. Consider an atom of silicon. What is its stability status?

5.7 Radicals

A radical is a group of chemically combined atoms that behave as if they are a single ion in reactions. Radicals have charges.

Table 5.6: Some radicals and their symbols

Radical	Symbol
Sulphate	SO_4^{2-}
Carbonate	CO_3^{2-}
Sulphite	SO_3^{2-}
Hydroxyl	OH^-
Hydrogen carbonate	HCO_3^-
Phosphate	PO_4^{3-}
Nitrate	NO_3^-
Hydrogen sulphate	HSO_4^-

5.8 Valence of elements and radicals

The valence of an element is its combining power when it forms chemical compounds and molecules.

In metals, the valency is the number of electrons in the outermost energy level. In non-metals, it is the difference between group 8 and group number of the elements. For radicals and ions, valency is the value of the charge on the ion.

Self evaluation test 5.3

- The symbol of an element B is represented by $\begin{matrix} 27 \\ \text{X} \\ 13 \end{matrix}$
 - Calculate the number of neutrons in the atom of B.
 - State the number of electrons in the atom of B.
 - Write the electronic configuration of B.
- Study and complete the table below.

Sub atomic particle	Symbol	Charge	Location in the atom
		-1	
Neutron			
			Nucleus

- Why do you think we always have vehicles with different registration numbers?

5.9 Chemical Formulae and nomenclature

As we had learnt earlier, sharing of possessions leads to happiness, stability and unity within our communities. The same applies to atoms. Atoms become stable after gaining or losing electrons. Atoms can act generous just like human beings!

However, they become electrically charged and any other oppositely charged atoms with the exact size of the charge has the potential of bonding with such an atom. When two ions combine, a compound is formed. A compound is represented by a formula.

A **chemical formula** is written using chemical symbols and valencies.

Example:

a) Sodium chloride;

- The chemical symbols involved are **Na** and **Cl**; with valencies **1** and **1** respectively.
- Write the valencies as superscripts after each symbol **Na¹Cl¹**.
- Interchange the valencies and write them as subscripts after each symbol **Na₁Cl₁**.

In the formulae; number 1 is not written.

Note: The three rules apply each time you write a formula.

Therefore the chemical formula of sodium chloride is **NaCl**.

b) Magnesium chloride;

The chemical symbols involved are **Mg** and **Cl**

Applying rule no.1 **Mg** and **Cl**; with valencies **2** and **1** respectively

Applying rule no.2 **Mg²Cl¹**

Applying rule no.3 **Mg₁Cl₂**

Chemical formula for magnesium chloride is **MgCl₂**

c) Aluminum oxide; chemical symbols involved are **Al** and **O** with valencies **3** and **2** respectively.

2. **Al³O²**

3. **Al₂O₃**

Chemical formula for aluminium oxide is **Al₂O₃**

d) Calcium nitrate; chemical symbols involved are **Ca** and **NO₃** with valencies **2** and **1** respectively.

2. **Ca²NO₃**

3. **Ca₁(NO₃)₂**

Chemical formula for calcium nitrate is **Ca(NO₃)₂**

Note: When writing a formula composed of radicals, introduce brackets when the radicals are more than one in a molecule.

Activity 5.2

To demonstrate how valency of elements contribute to the chemical formula of compounds.

Materials

Pair of scissors, manila paper

Procedure

1. Using the pair of scissors make pieces of manila paper that are 4 cm square as shown.

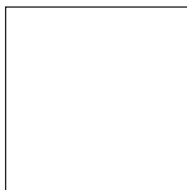

2. Cut two pieces of manilla into two different shapes as shown below.

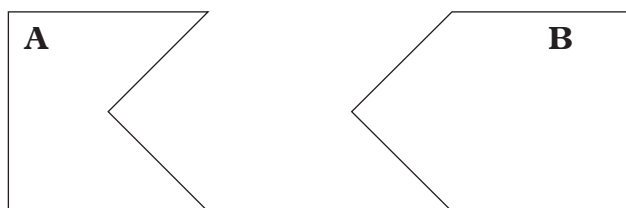

3. Try joining A and B to fit into each other as shown.

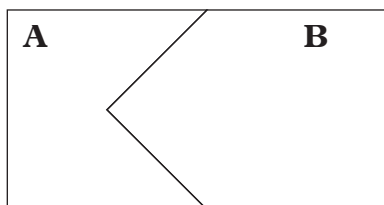

As you can see, the two fit together to form one shape. This is because **A** has one groove while **B** has one projection. We can therefore liken the projection and groove to valencies. This therefore can explain how elements with a valency of one combine to form a compound. An example is sodium and chlorine combining to form sodium chloride (NaCl).

4. Now make two grooves in another piece of manilla as shown. Try fitting it to another piece that has only one projection.



How many pieces of **Y** are needed so that the grooves in **X** are completely filled? We need two of piece **Y**.

Assuming **X** is magnesium and **Y** is chlorine. Then we shall require two atoms of chlorine to combine with one atom of magnesium. Hence the formula of magnesium chloride is MgCl_2 .

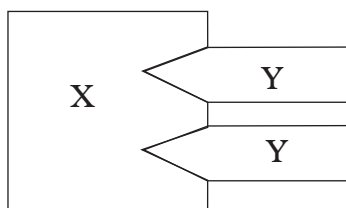

5. Use the same procedure to show that the formula of the following is correct.
- Aluminium chloride (AlCl_3)
 - Aluminium oxide (Al_2O_3)
 - calcium nitrate ($\text{Ca}(\text{NO}_3)_2$)

Combining power of non-Metals

Sometimes non-metal atoms combine with other elements to form molecules.

The molecules may be of similar atoms, for example O_2 or of different atoms for example H_2O .

Table 5.7: Various non-metals and a number of molecules they form

Element	Symbol	Combining Power	Example of Molecules
Hydrogen	H	1	H_2 , H_2O , CH_4
Carbon	C	4	CO_2 , CO
Oxygen	O	2	O_2 , CO, H_2O
Sulphur	S	2	H_2S , SO_2
Chlorine	Cl	1	HCl, NaCl
Bromine	Br	1	KBr, Br_2 , HBr
Iodine	I	1	KI, NaI
Nitrogen	N	3	N_2O , NO

Remember the facts...

- An element is a type of matter composed of atoms that all have the same atomic number
- An atom is the smallest particle into which an element can be divided without losing the chemical properties of the element.
- A molecule is the smallest particle of a compound or a gaseous element that can exist in free and separate state.
- A compound is a molecule that contains at least two different elements.
- Protons, electrons and neutrons are the main components of an atom.
- Mass number is the sum of protons and neutrons.
- Isotopes are atoms of the same element with the same number of protons but different number of neutrons.
- Atoms gain or lose electrons in order to attain stability.
- Radicals are a group of atoms, which react as if they are a single unit.

Test Your Competence 5

1. Study and complete the table below which shows how compounds are formed from metal ions and non-metal ions.

Cation / Anion	OH ⁻	SO ₄ ²⁻	NO ₃ ⁻	CO ₃ ²⁻
Ca ²⁺				
Na ⁺		Na ₂ SO ₄		
NH ₄ ⁺				(NH ₄) ₂ CO ₃
Cu ²⁺			Cu(NO ₃) ₂	
K ⁺	KOH			

2. (a) Name the four elements contained in Sodium hydrogen carbonate.
 (b) Given the positive ion K⁺ and negative ion HSO₄⁻ write the formula of the compound that would be formed if the two ions combined.
3. Some molecules are compounds. **True or false.**
4. I am chlorine atom with mass number 37. I also have a close relative with mass number 35. What is the appropriate name that you can use to refer to me and my relative?
5. Is oxygen a molecule or a compound? Give an explanation for your answer.
6. An atom consists of three sub-atomic particles namely ____, ____, and ____.
(For questions 7 and 8, choose the most appropriate answer.)
7. Atoms always react because they want to _____.
 (a) Be with other atoms.
 (b) Form molecules
 (c) Attain stable electronic configuration.
 (d) Gain electrons
8. Valency is the _____.
 (a) Number of electrons an atom needs to gain to be stable.
 (b) Combining power of an element.
 (c) Number of electrons in the outermost energy level.
 (d) Total number of electrons in an atom.
9. Using crosses to represent electrons, show how the following atoms attain stability.
 (a) Calcium
 (b) Oxygen
10. An atom X (not its chemical symbol) is atomic number 19.

- (a) How many protons does it have in its nucleus?
- (b) If its mass number is 39, calculate the number of neutrons in its nucleus (show your working).
- (c) Using crosses to represent electrons, draw a diagram to show the arrangement of electrons in X.
- (d) Does X become stable by gaining or losing electrons? Explain.

Consider the sitting arrangement in your classroom. How are girls and boys seated in terms of positions? Are there students with hearing impairment in your class? If there are, where do they normally sit? Why do you think the chalkboard is where it is? What about the noticeboard? Why do you think this kind of arrangement is preferred?

Now look at Fig 6.1. What does it show? Can you identify some items in the picture? How are they arranged? Why?



Fig 6.1 Arrangement of items in the supermarket.

Key unit competency

After studying this unit, I should be able to use the atomic number, valence electrons and number of shells to classify the first 20 elements in the Periodic Table.

Unit Outline

- 6.1 Dobereiner's triads and Newlands octaves
- 6.2 Historical development of the modern Periodic Table
- 6.3 The modern Periodic Table
- 6.4 Relationship between electronic structure of elements and their position on the Periodic Table.

Introduction

Naturally, human beings like to categorise things. Sometimes they do so just for display. However, most of the time, items are categorised and arranged in a particular order so that they can be easily found. In some cases, special materials are usually placed in certain places.

Similarly, elements should be arranged in a particular way for ease of study.

Before written history, people were aware of some of the elements in the Periodic Table. Such elements include gold, silver, copper, lead, tin and mercury. By 1869, 63 elements had been discovered. There are over 110 known elements today. These elements and their compounds have such a wide range of physical and chemical properties. It would be almost impossible to study and learn about them without some form of **classification**. In an attempt to classify elements, the earlier scientists went through various stages.

6.1 (a) Dobereiner's triads

In 1828, **J.W Dobereiner**, a German chemist, realised that some elements that had similar chemical properties could be arranged in groups of three. He called these groups of three, **triads**. This began in 1817 when he noticed that the atomic weight of strontium was halfway between the weight of calcium and barium. By 1829, he had discovered a halogen triad made up of chlorine, bromine and iodine. Later, he also found an alkali metal triad of lithium, sodium and potassium. Two other such groups of triads were:

Group 1	Group 2
Beryllium	Sulphur
Magnesium	Selenium
Calcium	Tellurium

Dobereiner noted that members in a triad had similar physical and chemical properties. The atomic mass and properties of the middle element of the triad was approximately the arithmetic mean of the other two.

Limitations of Dobereiner's classification

1. Many elements could not follow the **Law of Triads** yet they are similar. For example copper, manganese, iron, nickel, cobalt and zinc.
2. It is possible that quite different elements could be grouped into triads.
3. Also poor accuracy of measurements, such as measuring atomic weights, hindered grouping of some elements.

However, the law of Triads had shown that elements could be classified on the basis of relative atomic masses.

6.1 (b) Newlands' Octaves

In 1865, **John A.R Newlands**, an English chemist, arranged elements in ascending order of their atomic masses. He observed that any one element had properties similar to those of the element eight places from it; in the same way as the eighth note in an octave of music. He called this relationship the **Law of octaves**.

To show the pattern clearly, he arranged the elements in seven vertical groups as follows.

Table 6.1: The seven vertical groups proposed by Newlands

H	Li	Be	B	C	N	O
F	Na	Mg	Al	Si	P	P
Cl	K	Ca	Cu	Ti	Mn	Fe

In the table, the eighth element from lithium is sodium and the eighth element from sodium is potassium. According to Newlands' Law of Octaves, the properties of these elements must be similar and they in fact are.

Newlands was the first to give a number to an element and left spaces for elements not yet known by then. The periodic repetition of elements with similar properties in Newland's Octaves led to the name **Periodic Table**.

Newland's Law of Octaves was not taken seriously as it only worked well for the first seventeen elements. For others, most of the eighth elements did not have similar chemical properties with the preceding element, in the same group. Hence, the Law of Octaves was rejected by many other scientists. They later found it insightful after the works of Mendeleev and Meyer were published.

6.2. Historical development of the modern Periodic Table

Although the works of Dobereiner and Newlands were partly successful, their groupings were kind of flawed.

The breakthrough came in 1869, when a Russian Chemist **Dmitri Mendeleev** put forward his ideas on the Periodic Table. In his first attempt, he used 32 of the 61 elements known at that time.

The results led him to prepare a Periodic Table. He used it to predict the existence and properties of a number of unknown elements.

Thus in 1869, Dmitri Mendeleev arranged elements in order of their relative atomic masses. He then came up with the Periodic Law which states that "**the properties of the elements are a periodic function of their atomic weight**". This means that when elements are arranged in order of their increasing atomic weights, elements with similar properties appear at regular intervals.

He arranged elements in horizontal rows; in order of their ascending atomic weights. He named these rows **periods**. He also grouped elements with similar properties in vertical columns. He called the columns **groups or families**.

He left blank spaces for elements that had not yet been discovered by then; for example **noble gases**. Mendeleev's work became limited when no one was able to measure atomic number. To many scientists, it was just the position of an element in the Periodic Table sequence.

In 1913, **Henry G. Moseley**, an English scientist, found and measured a property linked to Periodic Table position. Moseley used a device called an electron gun to fire a stream of electrons at samples of elements. He found that the elements gave off X rays. He measured the frequency of the X rays given off by different elements. Each element gave a different frequency. This frequency was mathematically related to the position of an element in the Periodic Table. He could actually measure the atomic number.

Moseley called the position of the elements in the Periodic Table the **atomic number**. For the first time scientists were able to be confident of the correct order of the elements. They could recognise where elements were missing from the sequence.

Moseley numbered elements from 1 (hydrogen) to 92 (uranium). These numbers are called **atomic numbers**.

The works of Mendeleev and Moseley led to the modern Periodic Table. Scientists have continued with the work of discovery and creation of more elements.

My environment, my life!

Some of the newly created elements are harmful due to their radioactive nature. Can you name some of these elements?

Self evaluation test 6.1

1. Give a brief account of why you think contribution by the following scientists on the development of the modern Periodic Table cannot be ignored.
 - (a) Lothar Meyer
 - (b) Dmitri Mendeleev
2. State the weakness of Mendeleev's work on the modern Periodic Table.
3. The contribution of Henry Moseley on the modern Periodic Table gave scientists confidence of the correct order of the elements in the Periodic Table. Explain.
4. Why do you think pharmacists arrange drugs in a certain way in their shops?

6.3 The modern Periodic Table

All modern forms of the Periodic Table are based on Mendeleev's original idea. The principal characteristics of the modern Periodic Table are:

- (i) The elements are arranged in a strict order of their **atomic numbers**. The **Periodic law** states that "**properties of elements are a periodic function of their atomic numbers.**"
- (ii) The elements are arranged in vertical columns called **groups**. There are eight groups. Properties of elements conform to some pattern. Therefore, knowing the properties of one element in a given group makes it possible to predict the properties of other elements in the same group.
- (iii) Similarly, gradation of properties from one group of elements to the next group conforms to some pattern.
- (iv) Some groups of elements are given special names as follows:
 - Group 1: - **Alkali metals**
 - Group 2- **Alkaline Earth metals**
 - Group 17- **Halogens**
 - Group 18 or O or **Noble gases**
- (v) The elements are also arranged in horizontal rows called **periods**. There are 7 periods. In each period, there is transition from metallic to non-metallic characteristics.

I have discovered that...

In hardware shops, we find sections for roofing, flooring decoration, windows and doorframes, painting and coating materials.

Just like in a hardware shop, elements in the Periodic Table are arranged into periods and groups in which they belong.

The Facts

Arrangement of elements in the Periodic Table takes into consideration the atomic numbers of elements. Atomic numbers help us to write the electronic configurations of elements. From the electronic configuration, we can locate the position of an element in the table.

Further activity

1. The table below shows the names, symbols and atomic numbers of the first twenty elements. Complete the table by writing the electronic configuration, group and period to which each element belongs.
2. Write a report and present it to the class.

Element	Symbol	Atomic number	Electronic configuration	Group	Period
Hydrogen	H	1			
Helium	He	2			
Lithium	Li	3			
Beryllium	Be	4			
Boron	B	5			
Carbon	C	6			
Nitrogen	N	7			
Oxygen	O	8			
Fluorine	F	9			
Neon	Ne	10			
Sodium	Na	11			
Magnesium	Mg	12			
Aluminium	Al	13			
Silicon	Si	14			
Phosphorus	P	15			
Sulphur	S	16			
Chlorine	Cl	17			
Argon	Ar	18			
Potassium	K	19			
Calcium	Ca	20			

In your report:

- (a) Classify elements with same number of electrons in the outermost energy level.
- (b) Classify elements with same number of energy levels.

3. Establish the relationship between the electronic structure and the position of an element in the modern Periodic Table.

The following table summarises the electron configuration of the first twenty elements, the respective group, and the periods to which they belong.

Table 6.1 Electronic arrangement of the first 20 elements

Element	Atomic number	Electronic configuration	Group	Period
H	1	1	1	1
He	2	2	2	1
Li	3	2.1	1	2
Be	4	2.2	2	2
B	5	2.3	3	2
C	6	2.4	4	2
N	7	2.5	5	2
O	8	2.6	6	2
F	9	2.7	7	2
Ne	10	2.8	8	2
Na	11	2.8.1	1	3
Mg	12	2.8.2	2	3
Al	13	2.8.3	3	3
Si	14	2.8.4	4	3
P	15	2.8.5	5	3
S	16	2.8.6	6	3
Cl	17	2.8.7	7	3
Ar	18	2.8.8	8	3
K	19	2.8.8.1	1	4
Ca	20	2.8.8.2	2	4

From the table, it is clear that the:

- (i) Elements in the same group have the same number of electrons in the outermost energy level. For example all group I elements have one electron in their outermost energy levels. All group two elements have two electrons in their outermost energy levels. Thus the group number to which an element belongs is equivalent to the number of electrons in its outermost energy level.
- (ii) Elements in the same period have the same number of energy levels. If we want to know the period of a given element, we count the number of energy levels it has. If it has 3 energy levels, it is in the third period.

Note!

Hydrogen is placed at the top of group 1. This is done because:

1. It has one valence electron like group 1
2. It forms an ion by losing one electron.

Helium is placed in the eighth group because it has a fully filled outermost energy level. Its properties also match those of the other elements in the group.

Self evaluation test 6.3

1. (a) The following table gives atomic numbers of elements A, B, C, D and E. (The letters do not represent the actual symbols of the elements)

Element	Atomic number	Electronic configuration
A	3	
B	17	
C	19	
D	9	
E	12	

Complete the table by filling in the electronic configurations of the elements.

- (b) From the table in 1(a) above, identify elements which are in the same group and those that are in the same period.
- (b) How important is the atomic number in relation to the Periodic Table?
2. Hydrogen is placed on top of group I and not in group VII yet it is a nonmetal. It can also gain a single electron to attain stability. Why do you think this is so?
3. A form two student wanted to investigate reaction of the following metals with water: sodium, magnesium, aluminium and silicon. However, she realised that she did not have magnesium just before the experiment. What would you advise her to do?
4. Iron sheets are usually placed on the floor in a hardware shop. Why do you think this is done?

6.5 Metallic and non-metallic trends in the Periodic Table

As one moves from the left to the right across a period, metallic character decreases. This is because the attraction between valence electrons and the nucleus becomes stronger. This in turn makes the loss of electrons difficult.

Down the group, there is decrease in the attraction of the nuclei and the electron cloud. This is due to an increase in number of energy levels. The atoms then become bigger. This makes the loss of electrons easier hence an increase in metallic character.

The Facts

Generally, metals are placed on the left hand side of each period while non-metals are placed on the right hand side. The semi-metals are placed on the boundary between the metals and non-metals.

The metals are mainly found in groups 1, 2 and 3. Non-metals are found in groups 15, 16, 17 and 18. The dividing line between metals and non-metals appears as a zigzag line as shown in the following portion of the Periodic Table.

B	C	N	O	F	Ne
Al	Si	P	S	Cl	Ar
Ga	Ge	As	Se	Br	Kr
In	Sn	Sb	Te	I	Xe
Tl	Pb	Bi	Po	At	Rn

As we go down the group, the metallic character increases. This makes it increasingly easier to lose the valence electrons. Due to this, reactivity increases down the group. For example in-group I, sodium loses electrons more readily than lithium. Sodium is hence more reactive than lithium.

Down a group, the non-metallic character decreases. This is because down such a group, it becomes increasingly difficult to gain an electron. This is due to increasing atomic radius. For example fluorine gains an electron more readily than chlorine. Therefore fluorine is more reactive than chlorine.

Across the period, moving from left to right, the metallic character decreases as the non-metallic character increases. In period 3, we begin with metals, followed by metalloids, then non-metals.

However, reactivity of metals decreases up to aluminium. It then begins to increase for non-metals with chlorine being the most reactive.

Thus across every period we begin with metallic properties and ending on the right with non-metallic properties.

Self evaluation test 6.4

1. What is the relationship between electronic arrangement and the position of an element in the Periodic Table?
2. Explain the trend in:
 - (a) Metallic character down a group.
 - (b) Non-metallic character across a period.
3. How is the knowledge of metallic trends useful to an electrician?

Remember the facts...

- In 1828, Dobereiner showed that many elements could be classified into groups of three (triads) by using their atomic numbers.
- Newlands, in 1864, arranged elements in order of their atomic weights. He found that the chemical and physical properties of every eighth element were often identical.
- Mendeleev prepared the first Periodic Table of elements using atomic weights.

- Moseley arranged the elements from no 1 (hydrogen) onwards and came up with the idea of atomic numbers.
- The modern Periodic Table consists of 18 vertical columns called groups. Properties of elements in a group are chemically related.
- There are seven horizontal rows of elements called periods.
- The elements are arranged in the Periodic Table based on their atomic numbers.
- The groups on the left of the modern Periodic Table contain metals while those on the right contain non-metals.
- The number of valence electrons in an atom of an element is equal to its group number.
- The number of energy levels as written in the electronic structure is equal to the period the element belongs to.

Test Your Competence 6

- (a) Name three scientists who worked on the classification of elements.
(b) What criteria is used to arrange the elements in the modern Periodic Table?
- The following table gives the atomic numbers of elements P, Q, R, S and T. Study it and answer the questions that follow. (The letters are not the actual symbols of the elements)

Element	Atomic number
P	3
Q	6
R	9
S	11
T	14

- Identify the elements that belong to group 1.
 - Which elements belong to the same period?
 - Give reasons for your answers in (a) and (b) above.
 - Categorise the elements above into metals, metalloids and non-metals.
- Given the following elements and their atomic numbers as A=3, B=9, C=12, D=16, E=18, F=20, find out which of these elements is:
 - A halogen
 - Noble gas
 - Alkali metal
 - Alkaline earth metal
 - The following grid represents the modern Periodic Table. Study it and answer the questions that follow.

- Name the general term used to describe elements in the shaded region.
 - Sodium, magnesium, chlorine, argon and potassium have atomic numbers 11,12,17,18 and 19 respectively. Indicate the positions of these elements on the grid.
 - Another element Y belongs to group 13 period 2. Indicate the position of element Y on the grid.
- The following diagram represents part of the Periodic Table with elements A, D, E, F, G and H (Letters do not represent the actual symbols of the elements).

	1							2
A	3	4	5	6	7	8	9	10
D	11	12	E	13	14	15	H	16
F	19	G	20					

- (a) Which of these elements is:
- a noble gas
 - the most reactive metal
 - the most reactive non-metal
 - a non-metal
- (b) How many electrons are in the outermost energy level of element E?
5. (a) Elements in the present-day Periodic Table are arranged in order of _____ whereas in Mendeleev table, they were arranged in order of their _____.
- (b) Describe the attempts made by the following scientists to classify elements: Dobereiner and Newlands.
6. (a) An element V is in period 3 and group 17. Write the electronic structure of V.
- (b) What is the family name for the group to which element V belongs?
7. Mercury is known to be a poisonous substance when inhaled.
- Can you name any other element related to the poisonous nature of mercury?
 - What effects does it have on the environment?
8. Which of the following statements applies to triads?
- Members of a triad have similar physical properties.
 - Triads have similar chemical properties.
 - The properties of the middle element are the arithmetic mean of the other two.
 - Elements in a triad definitely belong to one group.

Have you ever thought of life without water? Research has shown that over 70% of the surface of the earth is covered by water. Where does the water come from? Look at the picture below with your friend.

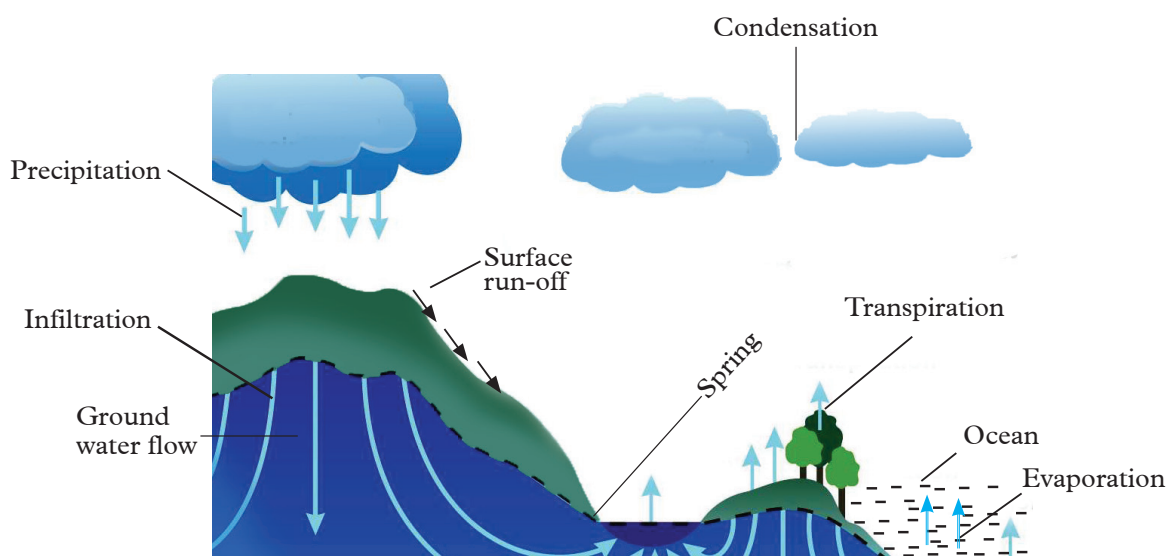

Fig 7.1 The water cycle.

Discuss what is going in the picture. What do you think is the importance of what is going on in the picture?

Key unit competency

After studying this unit, I should be able to state the standard requirements for different categories of water and explain the steps involved in water treatment.

Unit Outline

- 7.1 Sources of water
- 7.2 Physical properties of pure water
- 7.3 Testing the presence of water in a given substance
- 7.4 Characteristics of different categories of water
- 7.5 Treatment and purification of water
- 7.6 Uses of water
- 7.7 Water cycle

Introduction

Water is considered to be the most abundant compound on earth. It is present in the atmosphere as moisture, on the surface of the earth and in the bodies of all living organisms. What other places can we find water? Name them. Water is important as it is used for domestic, industrial and recreational purposes. Think of other specific uses of water at home and at school.

Health check!

Always drink treated water to avoid contracting water-borne diseases.

The water cycle ensures that water exists in all states of matter at all times. This property makes it accessible to all living organisms. Water provides a habitat for growth and multiplication of bacteria as well.

7.1 Sources of Water

Water covers over 70% of the earth's surface. It provides a habitat to aquatic organisms. The human body is also majorly composed of water. The major sources of water include underground water, surface water and rainwater.

1. Underground water

It flows within aquifers below the water table. Sometimes due to high pressure, the water rushes out in form of a spring. It can be obtained by drilling and sinking tubes. Underground water contains dissolved salts from rocks.

2. Surface water

This includes water present on the surface of the earth. It occurs in form of rivers, lakes, seas and oceans. This kind of water is naturally replenished by precipitation and melting of snow. It is naturally lost through evaporation. Water of this type also contains dissolved salts of the area from which it originates.

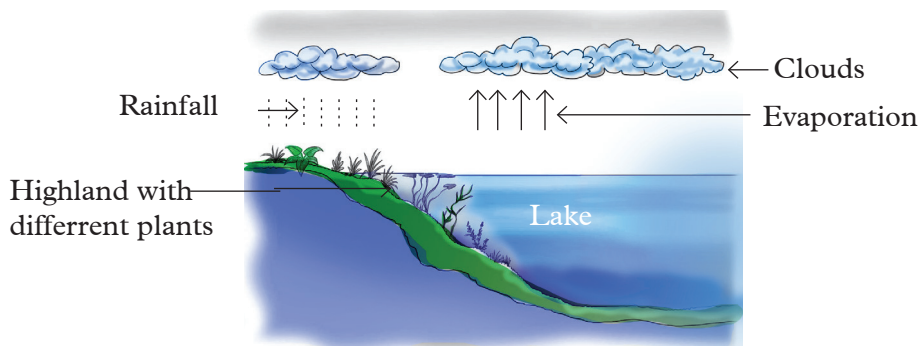

Fig 7.2 A lake is a source of surface water

3. Rainwater

It collects on the earth in form of surface and underground water. Originally, it is in the atmosphere as clouds, which come back to earth in form of rain.

My environment, my life!

We should conserve our water sources by planting more trees!

7.2 Physical properties of pure water

Activity 7.2

Determining the boiling point of pure water

Given the following apparatus and reagents, demonstrate how you would determine the boiling point of water

Apparatus and reagents

Beaker, tripod stand, wire gauze, thermometer, Bunsen burner, matchbox, sample of water.

Discussion corner!

1. Explain how the thermometer is used in the experiment.
2. (a) What value did you read from the thermometer?
(b) What happened to the temperature of water after boiling started?

I have discovered that...

When measuring the boiling point of water, the thermometer is held on top of the water. This is to ensure that only the temperature of water vapour is measured. When boiling starts, temperature remains constant.

Money matters!

Avoid dipping the thermometer bulb in the boiling water. It can easily break yet the apparatus is expensive.

The Facts

The boiling point of water is definite. Pure water boils at 100°C but it increases if the water contains impurities. Such impurities may include dissolved salts.

Further activity

Your teacher will provide you with samples of water in beakers and you are expected to carry out the following activities:

1. Observe and note down the colour.
2. Hold the beaker close to your nose and smell it.

Study questions

1. Are the colours of water in the beakers different? If so what is the reason?
2. What should be the colour of water?

3. How does pure water smell?
4. What is the taste of water?

The Facts

Pure water is a colourless, odourless and tasteless liquid.

Other physical properties of pure water include:

1. A freezing point of 0°C at sea level
2. A density of 1.00 g/cm^3 at 4°C
3. Poor ability to conduct electricity.

7.3 Testing for the presence of water in a given substance

We already have learnt that pure water boils at 100°C . This can be used as a confirmatory test for water. But there is a chemical test for water. Water turns white anhydrous copper (II) sulphate blue. Also, water turns blue anhydrous cobalt (II) chloride purple.

Activity 7.3

To investigate what is produced when copper (II) sulphate crystals are heated

1. Place some small hydrated copper (II) sulphate in a dry test tube. Note the colour of the crystals.
2. Set up apparatus as shown below.

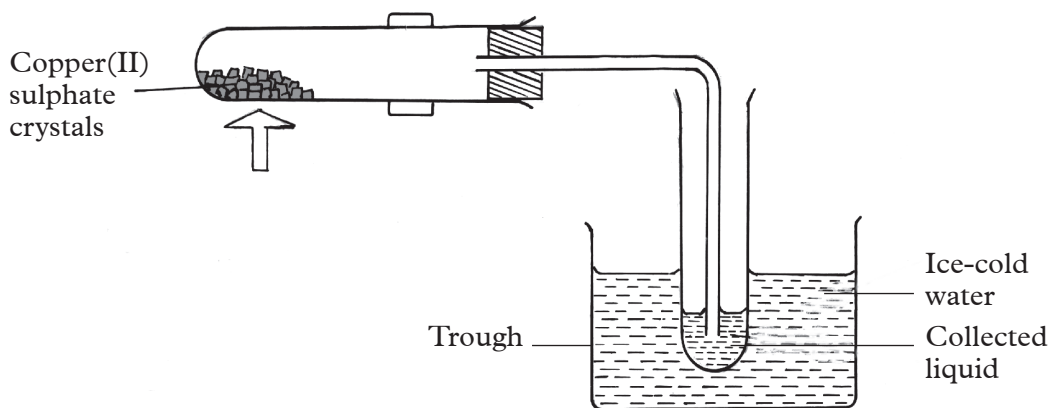

Fig 7.3: Heating copper (II) sulphate crystals

3. Heat hydrated copper (II) sulphate until there is no further change then remove the delivery tube.
4. Allow the liquid in the test tube to cool.

5. Add a few drops of the liquid collected into a test tube containing white anhydrous copper (II) sulphate. What do you observe?
6. Add drops of the same liquid to blue anhydrous cobalt (II) Chloride. What do you observe?

I have discovered that...

When blue copper (II) sulphate crystals are heated, a white substance is formed. A liquid collects in the second test tube. When this liquid is added to blue anhydrous cobalt (II) chloride, it changes to pink. Adding the same liquid to white anhydrous copper (II) sulphate makes it change colour to blue.

The Facts

Water can be found in some substances in combined form. The liquid produced when hydrated copper (II) sulphate is heated, is water. The effect of water on anhydrous cobalt(II)chloride and anhydrous copper (II) sulphate shown in activity 7.3 is used as the test for water in the laboratory.

7.4 Characteristics of different categories of water

Water can be placed into the following categories:

Mineral water, distilled water, tapwater, rain water, waste water, drinking water among others.

1. *Characteristics of mineral water*

- This is water from a mineral spring that contains various mineral salts and sulphur compounds.
- Mineral water may be effervescent due to contained gases.

2. *Characteristics of distilled water*

- It is a colourless liquid, without odour or taste.
- Distilled water is also neutral.

3. *Characteristics of tap water*

- It is sometimes referred to as municipal water.
- Culturally assumed to be potable water (drinking water).

Health check!

Household water purification methods such as boiling may be used if the purity of tap water is in doubt.

Research activity

Research on the characteristics of the following categories of water. Do a presentation in class on your findings.

Wastewater, rainwater, drinking water, irrigation, swimming pool water and livestock water

7.5 Treatment and purification of water

Treatment of water makes it free from contamination. Contaminants can be disease causing microorganisms and the heavy metals.

Water may be treated differently in different communities. This depends on the quality of water, which enters the storage plant.

There are various essential steps involved in purification of water namely, coagulation, sedimentation, filtration and disinfection.

1. Coagulation

Removes dirt and other particles suspended in water. Alum and other chemicals are added to water to form sticky particles called '**floc**'. Floc attracts the dirt particles. The combined weight of the dirt and alum become heavy enough to sink to the bottom during sedimentation.

2. Sedimentation

In this process, water is put in a large container and left undisturbed. The large and heavy impurities settle at the bottom of the container. The clear water on top is then slowly transferred to a clean empty container. Filtration is then done to remove the impurities that might have escaped the sedimentation process.

3. Filtration

Water passes through filters. Some filters are made of fine sand, gravel and charcoal that help to remove even smaller particles.

4. Disinfection

A small amount of chlorine is added to kill any disease-causing microorganisms.

Other treatments of water include:

- (a) Addition of sulphur dioxide to remove excess chlorine.
- (b) Addition of lime to correct the acidity of water (pH).
- (c) A mixture of carbon and clay can be added to remove tastes and odours from water.



Fig 7.4 Water treatment plant in Rwanda

Health check!

Beware of contaminated water. It spreads disease-causing microorganisms.

Self evaluation test 7.1

Your teacher will organise for a field visit to a factory that purifies and packs drinking water. Examples can be Inyange and SULFO companies. After the visit, write a report and present it to the class.

Differences between pure water and clean water

Activity 7.4

1. (a) Discuss amongst yourselves where you always obtain water for drinking and cooking food while at home.
(b) Why do you prefer obtaining water from these places?
(c) How do you know that it is clean water?
(d) Is clean water the same as pure water? Explain.
2. What is likely to happen if we drink water that is dirty?
3. Discuss amongst yourselves the meanings of pure and clean then come up with a conclusion.

I have discovered that...

Water for drinking and cooking can be obtained from wells, rivers and lakes. This kind of water must be treated. Treatment kills disease-causing microorganisms and removes toxic substances that might be present in water.

The Facts

Pure water and clean water have the following characteristics.

Characteristics of pure water

1. Pure water is colourless, tasteless, odourless and clear.
2. Pure water exists in all the three states of matter.
3. It freezes to solid ice at 0°C and boils at 100°C.
4. Has a density of 1g/cm³.

Characteristics of clean water

1. It is free from contaminants such as heavy metals, bacteria, chlorides and fluorides.
2. It contains natural minerals.
3. It usually has natural spring taste.

7.6 Water Cycle

Discussion corner!

Reflect upon the following occurrences and answer the questions related to them.

1. Every morning, you see water droplets on materials left outdoors. But in the course of the day, the droplets disappear. Discuss what this implies and come up with points and ideas.
2. When it rains, surface run-off goes to the seas, oceans and lakes. Does this water contribute to the amount of rainfall in surrounding areas?
3. Where does rainfall come from? Discuss.

My environment my Life!

Polythene bags are pollutants hence they should be disposed of responsibly after the experiment.

I have discovered that...

At night, water vapour condenses. It then drops back on to the vegetation and materials as moisture.

Evaporation taking place in water bodies like oceans, seas and lakes contributes to the amount of rainfall in surrounding areas. Rainfall is as a result of condensed water vapour in the atmosphere.

The Facts

Water continuously circulates from water bodies to the atmosphere and back to the land and water bodies. This process is known as the **water cycle**.

Water evaporates from seas, oceans, lakes, rivers and leaves of plants. Loss of water from plant leaves is known as **transpiration**. The vapour condenses to form clouds and later falls as rain, hail, or snow that is **precipitation**. The rain or melting snow completes the cycles by flowing downstream into rivers, lakes and seas.

Water goes through different phases namely liquid, solid and gas during the cycle.

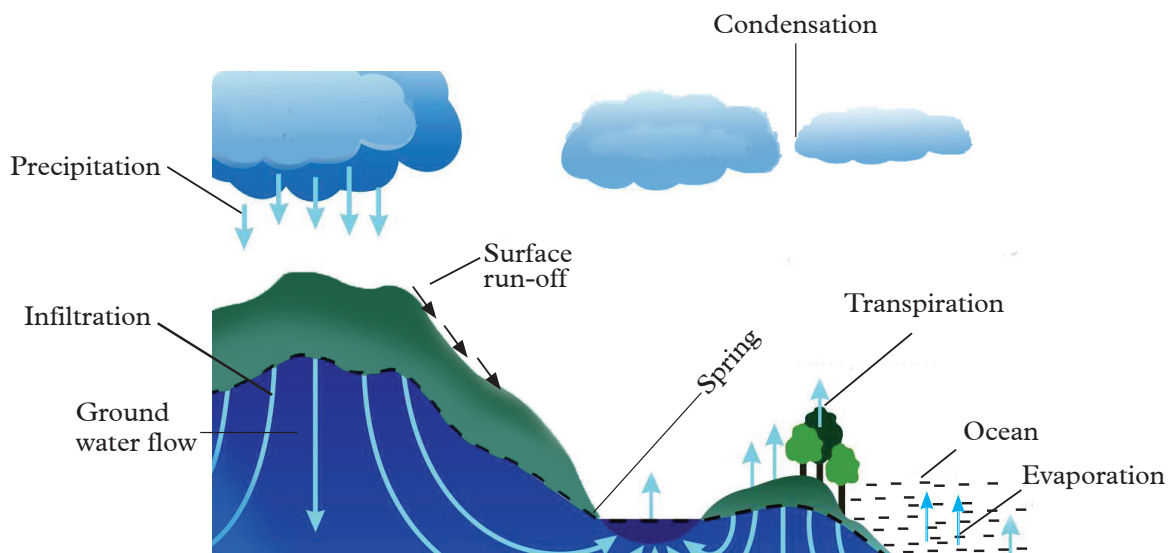

Fig 7.5. Water cycle

7.7 Uses of water

Discussion corner!

1. (a) Discuss some of the tasks that are accomplished using water?
(b) How is water applied in the activities?
2. Can you accomplish those tasks without water?
3. Is there an alternative substance you can use instead of water?

The facts

Water is important in the following ways.

1. For domestic purposes such as cooking, drinking and washing.
2. It is a natural solvent that allows many chemical reactions to take place in both plants and animals.
3. It is a habitat for many aquatic plants and animals.
4. It is used for irrigation in some areas.
5. Water is sometimes used to rotate turbines during hydroelectric power generation.
6. As a medium for transport and sometimes for recreation.
7. Water is also used to make many chemical solutions. Examples include drugs, food stuff, beverages, herbicides and insecticides.

The water cycle helps to keep a constant supply of water for daily use.

Remember the facts...

- Sources of water include underground water, surface water and rainwater.
- Some of the physical properties of pure water are that it is tasteless, odourless, colourless and it boils at 100°C .
- Different categories of water have different characteristics. For example, tap water is tasty while mineral water may be effervescent.
- Water is used in many domestic activities such as washing, drinking and cooking. In industries, water can be used in various processes for instance cooling machines.
- The water cycle helps to keep a constant supply of water for daily use.

Test Your Competence 7

1. Suppose you find an unlabelled container with a liquid in the laboratory. How would you show that the liquid inside is water?
2. State two ways in which water is useful in our bodies.
3. Clearly explain how you would treat water obtained from the river before you drink.
4. How would you know that bottled drinking water is safe for drinking?
5. Explain how swimming pool water can be maintained to prevent contamination.
6. To ensure that our country receives adequate rainfall and protect our water catchment areas, we should stop careless cutting down of trees. Explain how trees help in conservation of water catchment areas.
7. An outbreak of a disease has occurred in your neighbouring village. One of the symptoms of the disease is diarrhoea. Health officers say that the outbreak is due to drinking contaminated water. What do you think the residents should do to make sure that the water they use is clean and free from germs?
8. What can you advise your friend who leaves the tap running after fetching water?
9. The following are uses of water except _____.
 - A. Universal Solvent where biochemical reactions in our bodies take place.
 - B. Production of electricity.
 - C. Irrigation.
 - D. Soil erosion.
10. 'Water is life'. Write an essay on this topic and present it to your teacher for evaluation.

Earlier, you learnt about air being a **mixture**. What is air made of? What is its importance? What is air pollution?

Activity 8.1

1. Take some clean water and put in two glasses until half way.
2. Pour some oil in one of the glasses with water.
3. Shake the glass to mix the oil with water.
4. Compare the two liquids.



Fig 8.1 A Glass containing clean water



Fig 8.2 A Glass containing oil and water

- Is water in the glass mixed with oil safe to drink?
- How does it smell?
- What is your comment about this regarding pollution?
- Can the same thing happen to air?
- When it happens to air, what do we call it?

This unit is important in understanding the need to conserve our environment.

Key unit competency

After studying this unit, I should be able to assess the components of air, analyse the causes and prevention of air pollution.

Unit outline

- 8.1 Components of air and their percentages
- 8.2 Oxygen as the active part of air
- 8.3 Importance of air
- 8.4 Air pollution
- 8.5 Ways of preventing air pollution

8.1 Components of air and their percentages

Air is a homogenous mixture of gases. The composition of air does not vary much except for the moisture and pollutants. One of the most important components of air is oxygen. We need oxygen for burning (combustion reaction) and respiration. Can you mention other uses of oxygen?

The following table and pie chart show composition of air by volume.

Table 8.1: Percentage of air by volume

Gas	% Composition
Oxygen	20.9
Nitrogen	78.4
Carbon dioxide	0.03
Inert/or rare gases	1.0

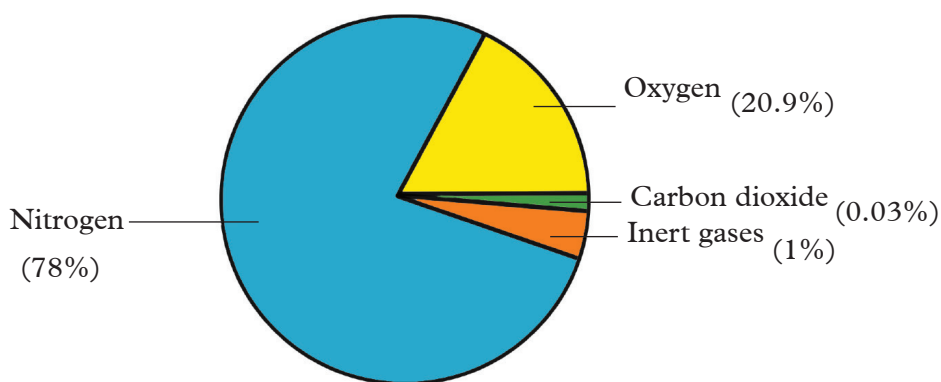

Fig 8.3 Composition of air

8.2 Oxygen as the active part of air

Activity 8.2

Investigating the percentage of the most active part of air

Apparatus

Syringes, hard glass tube, glass wool, Bunsen burner, matchbox

Procedure

1. Place a small amount of copper turnings into a hard glass tube. Then put glass wool at both ends of the tube.
2. Label one syringe A. Remove all the air from this syringe by pushing the plunger inside. Fix it lightly to one end of the glass tube. Label the other syringe B. Pull the plunger of B out to 100cm³ mark to fill the syringe with air.

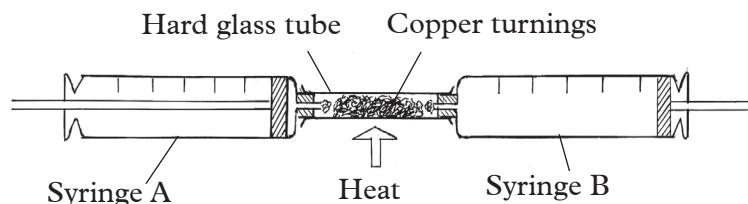

Fig. 8.4: Heating copper turnings

3. Heat the tube containing copper turnings strongly. Pass air over them by slowly pushing the plunger of the syringe B for several times.
4. When there is no further change in the volume of air left in the syringe B, allow the apparatus to cool.
5. Record the volume of air left in syringe B. What is the colour and name of the solid residue in the tube? Calculate the volume of air used up in the experiment.

I have discovered that...

The copper turnings that were brown at the start of the experiment, become grey-black. Also the volume of air decreases from 100 to about 79 cm³.

Calculations

Initial volume of air in syringe B = 100 cm³

Final volume of air in syringe B = 79 cm³

Volume of air used = 100 – 79 = 21 cm³

Percentage of air used = $\frac{21}{100} \times 100\% = 21\%$

This means that only 21% of air was used when copper was heated.

The Facts

Oxygen is the active part of air. It constitutes 21% of the air by volume.

Copper burns in oxygen to form copper (II) oxide. Copper (II) oxide is grey-black in colour.

8.3 Importance of air

We already have learnt that air is made up of many gases and water vapour. What role does air play in our lives? What is the function of the different components of air?

The following are some uses of air.

1. Animals take in oxygen when they breathe in and release carbon dioxide as a waste product. Oxygen is very important in a process called **respiration** which releases energy. This makes animals to be active.
2. Carbon dioxide is a raw material in **photosynthesis**. This is the process by which plants make their own food.

3. Carbon dioxide is also used in fire extinguishers to put out fire.
4. Mountain climbers and deep sea divers carry oxygen in tanks. This enable them to breath in areas with low oxygen supply.
5. Nitrogen in air makes it inert. Without nitrogen, most chemical processes would lead to explosions.
6. Moving air (wind) can be used to rotate turbines for electricity production.
7. We inflate tyres of vehicles with air. Vehicles make transport easy and fast.

8.4 Air pollution

Discussion corner!

In pairs discuss the following:

1. When a lorry is climbing a steep hill, it produces dark smoke with a bad smell.
2. Industries produce dark smoke into the air.
3. When we burn domestic waste, a bad smell is produced.
4. When a gas is leaking in the laboratory, we notice easily because of the bad smell.

I have discovered that ...

All these processes lead to production of gases that have a bad smell. These gases contaminate air.

The facts

Air pollution refers to the contamination of air by substances like dust, pollen, car emissions, chemicals and smoke from factories. There are several sources of air pollution.

Sources of air pollution

The major sources of air pollution are given below.

1. Carbon dioxide and carbon monoxide which result from burning of fossil fuels. Fossil fuels supply energy for both domestic and industrial purposes. An increased concentration of carbon dioxide and methane in the atmosphere raises global temperatures. Atmospheric temperatures are raised because the radiant energy from the earth is trapped. This occurrence is known as **greenhouse effect**.
2. Excess dust particles in the atmosphere reduce visibility hence making movement difficult.
3. Chlorofluorocarbons (CFCs from aerosols and refrigerators destroy the ozone layer. Ozone layer acts as a barrier to the ultraviolet radiations from the sun. Ultraviolet radiations cause skin cancer and they also damage crops.

4. Nuclear leakage from nuclear plants can also cause pollution by radioactive pollutants. Most of the nuclear explosions result from wars amongst nations. Some of the nuclear explosions result from wars amongst nations.
5. Other pollutants include gases produced by industries. Such gases include sulphur dioxide (SO_2), Nitrogen dioxide (NO_2) and Hydrogen sulphide (H_2S). Motor vehicles and volcanoes also produce some of these gases. When sulphur dioxide (SO_2) and nitrogen dioxide (NO_2) mix with water, oxygen and other chemicals in the atmosphere, they form **acid rain**. When acid rain falls on the earth, it has the following effects.
 - (i) Causes acidification of water bodies like lakes and streams. This destroys aquatic animals.
 - (ii) Causes damage to plant leaves causing them to wither.
 - (iii) Causes corrosion and damage of building materials like iron sheets.

Fairness is my other name!

Equitable distribution of resources is important for peaceful coexistence among communities.

When primary pollutants like nitrogen dioxide and other gases interact under the influence of sunlight they produce a mixture of many different hazardous chemicals as secondary pollutants. This condition is called **photochemical smog**.

8.5 Ways of preventing air pollution

Activity 8.3

Study questions

1. What kind of fuel do you use at home?
2. What are the effects of excessive burning of charcoal and use of firewood?
3. Are there alternative sources of fuel apart from firewood and charcoal? Name them.

I have discovered that...

Many households use firewood and charcoal as a source of fuel. When charcoal or wood is burnt, smoke and oxides of carbon are released into the atmosphere. Smoke and oxides of carbon are considered air pollutants.

The use of firewood and charcoal as sources of fuel for a long period of time can lead to desertification. It is important that we embrace the use of renewable sources of energy such as biogas.

The Facts

Major air pollutants result from combustion of fossil fuels. Some of these pollutants, their effects and preventive measures are given in table 8.2.

Table 8.2 Some air pollutants, their effects and preventive measures

Pollutant	Harmful effects	Prevention
Sulphur dioxide (SO ₂)	<ul style="list-style-type: none">• Irritates the nose and the respiratory tract.• Dissolves in water to form acid.• Damages leaves of plants.	<ul style="list-style-type: none">• Use of alternative fuels free of sulphur such as natural gas and liquid petroleum gas.• Factories to be fitted with acid scrubbers to absorb the gases.
Carbon monoxide (CO)	<ul style="list-style-type: none">• It binds in the sites of oxygen in Haemoglobin molecules readily impeding oxygen transport.• Causes dizziness, headache, impairs mental processes and can also cause death if exposed to the environment for a long time.	<ul style="list-style-type: none">• Use well tuned engines so that little CO is produced.• Use of catalytic converters fitted in exhaust pipes to oxidise CO to CO₂ or install tall chimneys in factories.
Hydrogen sulphide (H ₂ S)	It is a poisonous gas to living organisms and has a bad odour. It can be oxidised to form SO ₂ which is also toxic to the cells of living organisms.	<ul style="list-style-type: none">• Use low sulphur or sulphur-free fuels.
Nitrogen dioxide (NO ₂)	<ul style="list-style-type: none">• Reacts with sunlight to form a brown haze (photochemical smog) which irritates the eye and nose. It also retards plant growth.	<ul style="list-style-type: none">• Use of catalytic converters.
Smoke	Creates a smoky haze, aggravates respiratory problems, reduces sunlight penetration and coats leafy surfaces. This affects photosynthesis.	<ul style="list-style-type: none">• Removal of smoky dust particles from chimneys through electrostatic precipitation.• Use of alternative energy sources such as wind and biogas.

Self-evaluation Test 8.0

1. Discuss the following ways of reducing air pollution.
 - (a) Recycling
 - (b) Catalytic converters
 - (c) Afforestation
 - (d) Conservation policy
2. Gatete found two of his classmates smoking cigarettes. What was he supposed to do?

Remember the facts...

- Air is a homogenous mixture of gases.
- Oxygen makes up 21% of air volume.
- Introduction of harmful or poisonous substances into the atmosphere is called air pollution.
- Some of the gases which cause air pollution include carbon monoxide, carbon dioxide, sulphur dioxide and sulphur trioxide.
- Air pollution can be reduced through use of renewable sources of energy, catalytic converters in vehicles and acid scrubbers in factories.

Test Your Competence 8

1. A sugar factory decides to install tall chimneys as opposed to the use of electrostatic precipitators. This is because it is cheaper. Is this a good decision? What would you advise the management of this factory to do?
2. Air is a mixture of gases. Name a gas which:
 - (a) Makes up the biggest percentage of air.
 - (b) Is the most active part of air.
 - (c) Is a noble gas.
3.
 - (a) What is acid rain?
 - (b) Explain the effect of acid rain.
4. Suppose we continue cutting down trees without planting new ones, what would happen eventually?
5. Explain how each of the following activities is important in ensuring a non-pollutant environment.
 - (a) Re-afforestation
 - (b) Recycling
6. How best can air pollution be reduced?
7. A school in the outskirts of Kigali town owns a large tree plantation from which it obtains firewood. Due to increased enrolment, the management has realised that trees in the school farm are being depleted. If you were in the school management, what would you suggest?

Can you name some waste products that you generate in your household? How do you dispose of these wastes? Is it the correct way? Now look at these pictures.



Fig. 9.1 Landfill



Fig. 9.2 Throwing wastes in a dustbin

Discuss with your friend what is going on in the pictures. Which other ways can you use to dispose of wastes? Which method is the best? Explain why.

Key unit competency

After studying this unit, I should be able to minimise and properly manage waste.

Unit outline

- 9.1 Definition of waste
- 9.2 Types of waste materials
- 9.3 Sources of wastes
- 9.4 Sources of waste materials at school level and their management
- 9.5 Hazards of wastes to the environment

Introduction

Waste is a pressing environmental, social and economic issue worldwide.

Increasing consumption in developing economies continues to generate large amounts of waste. As a result, more effort is required to reduce these wastes.

While waste was viewed as disposable in the past, today it is increasingly being recognised as a **resource**. This is reflected in the way waste management is shifting away from just disposal to **recycling** and **recovery**. Think of how the waste materials around you can be recycled and reused.

9.1 Definition of waste

Activity 9.1

Study questions

1. Look at your environment. Are there things that you do not need? Name those things. Where did they come from?
2. What effects do those things have on the environment?
3. Discuss some of the ways waste materials can be put to good use.
4. Why do you think it is important to keep our environment clean?

I have discovered that...

Within our environment, we usually have things that we do not need. Some of these things result from daily use. They have become defective and unwanted. Examples of such things in the school compound are broken desks, old exercise books and writing materials. Most of these materials can be an eyesore if they are not put to use. This helps to reduce their effect on the environment. An environment free from wastes discourages growth of disease causing microorganisms.

The Facts

Waste is any **worthless** or **defective substance**, which is discarded after primary use. Waste materials can also be defined as unwanted or unusable materials. Although waste materials are usually considered to be pollutants and obstacles, most of them can be reused or recycled. Recycling waste materials not only saves our natural resources it also saves energy. Great amounts of energy are used when making new products from raw materials. Recycling already existing materials will require less energy.

My environment, my life!

Conservation of natural resources is important for sustainable development.

9.2 Types of waste materials

Activity 9.2

Study questions

1. Observing the environment around you, which kind of waste materials can you see?
2. Collect the waste materials. Observe them and describe them.
3. Suggest ways of grouping them.

I have discovered that...

Within the school environment, there are waste materials such as old waste papers, books, newspapers, broken desks, broken apparatus and bottles of reagent, unused and expired chemicals, food leftovers and wastes from the store.

These waste materials can be placed into three major groups:

1. Solid wastes
2. Liquid wastes
3. Gaseous wastes

The Facts

Waste materials can be categorised according to their sources and nature.

According to their nature, waste materials can be categorised into the following classes:

1. **Solid wastes:** These can be either biodegradable or non-biodegradable.
 - (a) **Biodegradable solid wastes:** These are solid wastes that can be broken down into simple compounds by microorganisms. Examples of such biodegradable solid wastes include remains of plants and animals, wastes from animals, papers and cotton wool clothes.
 - (b) **Non-biodegradable solid wastes:** These are solid wastes which cannot be broken down by microorganisms. Such wastes include polythene bags, metal scraps, pieces of glass and plastics. Some pesticides, such as DDT are also non-biodegradable if they find their way into the soil.
2. **Liquid wastes:** These include household wastes such as water from the kitchen, the bathroom and urinal. It also includes liquid chemicals from industries.
3. **Gaseous wastes:** They include the following categories of wastes:
 - (a) *Industrial* – sulphur dioxide, hydrogen chloride gases
 - (b) *Laboratory* – chlorine, ammonia gases
 - (c) *Waste obtained from the combustion of fossil fuels* – carbon monoxide, sulphur dioxide, carbon dioxide and nitrogen dioxide



Fig 9.3: A dumpsite

9.3 Sources of wastes

1. Municipal wastes are those obtained from homes and towns. They contain human wastes, soaps and detergents from washing machines and showers.
2. Medical wastes include drugs and cleaning materials such as cotton wool.
3. Industrial wastes include toxic gases such as Sulphur dioxide, which may dissolve in moisture and turn into acid rain, salts and mercury compounds.

9.4 Sources of waste materials at school level and their management

Waste materials in schools result from the laboratory, kitchen and classroom activities. They include:

1. **Laboratory wastes:** These wastes include broken apparatus and used chemicals.
2. **Kitchen wastes:** Include fruit and vegetable parts and food leftovers.
3. **Classroom wastes:** Torn papers, old newspapers, magazines and used stationery.

Self-evaluation Test 9.1

1. Given the following list of waste materials: broken test tubes, bottles, used chemicals, waste papers, bathroom water, kitchen and dining leftovers. Put them in appropriate categories.
2. Differentiate between biodegradable and non-biodegradable wastes.

9.5 Hazards of wastes to environment

The following are some hazards of waste to the environment.

1. Sewage contains disease-causing organisms which include bacteria and fungi. These can cause diseases such as cholera and typhoid.

Health check!

Always ensure you drink clean water to avoid contracting water-borne diseases.

2. Non-biodegradable wastes, such as polythene bags, destroy soil structure. This leads to poor soils that cannot support growth of crops.
3. Some gaseous wastes cause dizziness and headaches. They also cause impaired vision and contribute to the formation of acid rain. This kind of rain causes damage to crops and buildings.

Management of wastes

Activity 9.3

Study questions

1. Where do you discard food leftovers while in school?
2. Can food leftovers be put into other uses?
3. What are some of the ways used to dispose of the above wastes in school?
4. Why are the methods you have mentioned in (3) above preferred?

I have discovered that...

Waste from the kitchen and food leftovers can be put in a compost pit. It can then be left for months for it to decompose. The decomposed matter can then be used to enrich the soil during farming.

Money matters!

Always prepare compost manure to avoid incurring huge expenses of buying synthetic fertilisers during the planting season.

The Facts

There are various ways of managing wastes. These include:

1. Burying – This is used to dispose of animal carcasses.
2. Recycling – This is an economical way of managing wastes as it is usually expensive to manufacture new products.

Money matters!

*Save money, **recycle**, **reuse** and **reduce** waste materials. These are the **3Rs** of conservation.*

3. Sensitising the community to build toilets, clean homes and dig pits for biodegradable wastes.
4. Separation and incineration of wastes in hospitals after use.
5. Use of septic tanks to store waste water before treatment for recycling.

Remember the facts...

- Waste materials are substances which are considered worthless, defective and hence unwanted.
- Wastes can be categorised into solid, liquid and gaseous wastes.
- Sources of waste include municipal, medical and industrial sources.
- Sources of waste materials in schools include:
 - Laboratory wastes
 - Kitchen wastes
 - Classroom wastes
- Solid wastes are considered hazardous. They can form a habitat for disease causing microorganisms. Others are non-biodegradable which lead to infertile soils.
- Gaseous wastes cause environmental pollution.

Test Your Competence 9

1. Neza and Keza's parents instructed them to collect all the things they no longer use in the house. In the process they came up with the following things:
 - Broken plastic jars and tins
 - Old cartons
 - Old clothes and sheets
 - Spoilt toothbrushes
 - (a) What should the children do with these things?
 - (b) What advice would you give to Neza and Keza's parents next time they want to buy any household items?
2. During an art lesson, you are provided with the following: old chart papers and strings, old newspapers, glue and torn chart papers. Suggest some of the items you can make using these materials.
3. Name the sources of the following wastes:
 - (a) Sulphur dioxide and nitrogen dioxide
 - (b) Old and torn newspapers
4. "Recycle, reduce and reuse are better ways of waste management". Discuss.
5. Explain how the following laboratory wastes can be managed:
 - (a) Used chemicals
 - (b) Broken apparatus
6. We should avoid using bags made of synthetic material like plastic. What is the effect of plastic materials on the environment?
7. If well managed, wastes from the kitchen and food leftovers can be beneficial to us and other organisms. Explain.
8. Proper management of waste is beneficial to the economy of Rwanda. Explain this basing on the following:
 - (a) Saving money used in acquiring farm inputs.
 - (b) Availability of enough food for the population.
 - (c) Saving on health expenses.

What is a chemical reaction? How does it come about?

Activity 10.1

Procedure

1. Pour some soda(coke) on cemented floor. What happens?
2. Your teacher will now provide you with acid from a car battery.
3. Pour a small amount of the acid on a piece of paper. What happens?
4. How can reactions taking place be presented?

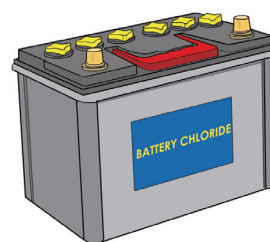

Fig 10.1 Car battery

Key unit competency

After studying this unit, I should be able to write and use balanced chemical equations and apply them in daily life.

Unit outline

- 10.1 Chemical reactions
- 10.2 Balancing chemical equations
- 10.3 Interpreting and translating word equations into chemical equations

10.1 Chemical reactions

Chemical reactions play an important role in our daily lives. When we look around us we see a variety of things that are products of chemical reactions.

Can you name some of these things?

Also, life sustaining processes such as respiration, digestion and photosynthesis occur through chemical reactions.

Activity 10.2

To observe what happens when a mixture of iron filings and sulphur powder are heated together

Materials and reagents

- Iron filings (grey in colour)
- Sulphur powder (yellow in colour)
- Test tube and test tube holder

- Bunsen burner
- Spatula

Procedure

(This is a demonstration to be done by the teacher).

1. Put a spatulaful of iron filings in the test tube.
2. Add another spatulaful of sulphur powder and shake to get a homogenous mixture.
3. Using the test tube holder, heat the mixture until no further change occurs.
4. Record your observations.

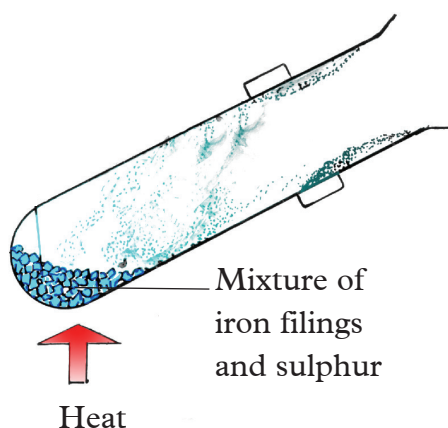

Fig 10.2: Heating sulphur powder and iron filings

I have discovered that...

When the mixture was heated a red glow was observed. A substance that was black in colour was formed.

The facts

When a chemical reaction like the one in activity 10.2 takes place, several observations are made. These include

- A substance disappearing
- Effervescence forming
- A precipitate forming
- A colour changing
- Temperature changing
- A smelly substance
- Light being given out

Which among these observations did you make in activity 10.2?

Chemical equations

During chemical reactions, the starting substances (**reactants**) are changed into new substances (**products**). The changes that take place during chemical reactions are normally represented using **chemical equations**. Therefore, a chemical equation is a short hand way of representing a reaction. A chemical reaction can be represented by a word equation or by use of chemical symbols. For example:

$A + B \longrightarrow C + D$ where **A** and **B** are reactants and **C** and **D** are products. The arrow means “**to give**”.

A chemical equation is however complete if written with state symbols. It is only meaningful when it is balanced.

The equations are balanced in order to comply with the **law of conservation of matter**. The law states that **matter cannot be created nor destroyed but can be changed from one state to another**.

This means that we must have the same number and types of atoms after a chemical change as were present before the chemical reaction took place.

Thus a chemical equation is a shorthand way of representing a chemical reaction. More over, it is a convenient and efficient way to communicate chemical information. It is used as an international code for describing chemical change.

Quality is my Choice!

- We should always use approved reagents when carrying out tests in the laboratory.
- We should avoid using expired reagents as well.

Writing chemical equations

Activity 10.3

Carry out the following tests then observe what happens.

1. Burn a piece of magnesium in a Bunsen burner flame.
2. Drop a piece of sodium in water.
3. Tabulate your results as shown below.

What happens in procedure 1?	What happens in procedure 2?

4. Research on the products that are formed in the two experiments. Write a report and present it to the class.

I have discovered that ...

Magnesium burns in air with a **brilliant white flame** to form magnesium oxide; a white solid.

Self-evaluation Test 10.1

- Write word equations for these reactions:
 - Hydrogen reacting with oxygen
 - Iron reacting with sulphur
 - Carbon reacting with oxygen
- Give the identities of P, Q and R in the following equations.
Sodium + chlorine \longrightarrow P
Calcium + Q \longrightarrow Calcium oxide
R + Iodine \longrightarrow Copper iodide

(b) Writing chemical equations using symbols

Activity 10.4

- In pairs, give examples of mathematical symbols you know. Also give the meaning of every symbol.
- Now research on what chemical symbols are.
- Compare use of chemical symbols in writing chemical equations to use of words.

I have discovered that...

Chemical equations can be made simpler if we write them using chemical symbols. Chemical equations are written using chemical symbols for each element.

The facts

Consider the reaction between magnesium and oxygen to form magnesium oxide. This reaction can be written using a more informative equation. We use symbols and formulae of the reactants and products instead of their names as shown below.

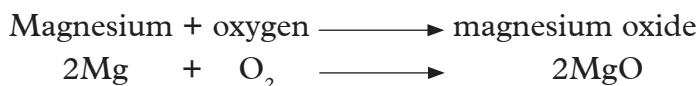

The reaction between zinc metal and dilute sulphuric acid can be written as:



The reaction between carbon and oxygen to form carbon dioxide can be written as:



(c) *Writing chemical equations with state symbols*

Activity 10.5

1. Work in pairs.
2. Remind yourselves about the various states of matter.
3. Write down the characteristics of these states of matter.

I have discovered that...

In a chemical equation, it is important to indicate the physical states of the reactants and their products. The state of each substance is represented by a state symbol, which is usually placed in brackets after each formula. The state symbols are as follows:

- **(s)** – Represents a solid, which could be in free form, in suspension or in a precipitate form.
- **(l)** – Represents a liquid.
- **(g)** – Represents gas or vapour form
- **(aq)** – Represents a substance that is dissolved in water to form a solution

The facts

Consider the reaction of zinc with dilute sulphuric acid to form zinc sulphate and hydrogen gas. The equation can be written together with state symbols as follows:



The reaction between magnesium and oxygen to form magnesium oxide can be written with state symbols as:

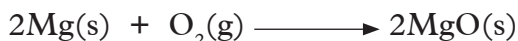

The reaction between carbon and oxygen to form carbon dioxide is written as



Task 2

1. Identify reactants and products from the following equations:
 - (a) Copper and oxygen \longrightarrow Copper oxide
 - (b) Sodium and chlorine \longrightarrow Sodium chloride
 - (c) Calcium and water \longrightarrow Calcium hydroxide and Hydrogen gas
 - (d) Hydrochloric acid and magnesium \longrightarrow Magnesium chloride and hydrogen gas
2. Identify the state symbols for the substances in brackets.
 - (a) $\text{H}_2(\text{g}) + \text{O}_2(\text{g}) \longrightarrow \text{H}_2\text{O}(\text{l})$ (water)
 - (b) $\text{Mg(s)} + \text{Cl}_2(\text{g}) \longrightarrow \text{MgCl}_2(\text{s})$ (magnesium chloride)
 - (c) $\text{S(s)} + \text{O}_2(\text{g}) \longrightarrow \text{SO}_2(\text{g})$ (sulphur dioxide)

Self evaluation test 10.2

1. What is the difference between a chemical reaction and a chemical equation?
2. Write word and symbolic equations for the following reactions:
 - (a) Sulphur burns in oxygen to form sulphur dioxide gas.
 - (b) Methane gas burns in oxygen to form carbon dioxide and water.
 - (c) Zinc metal reacts with hydrochloric acid to form zinc chloride and hydrogen gas.
 - (d) Copper oxide reacts with hydrogen gas to form copper metal and water vapour.
3. Write **true** or **false**.
 - (a) Temperature remains the same during chemical reactions.
 - (b) Light can be given out during a chemical reaction.
 - (c) A product disappears during a chemical reaction.
4. What does the arrow mean in a chemical equation?
5. Mugume opted to buy low quality magnesium to carry out an experiment because he did not have enough money. What would you advise Mugume to do?
6. Write symbolic chemical equations for the following reactions:
 - (a) Sodium hydroxide reacts with dilute hydrochloric acid to form sodium chloride and water.
 - (b) Potassium carbonate reacts with dilute nitric acid to form potassium nitrate, carbon dioxide and water.
 - (c) Sodium metal reacts with water to form sodium hydroxide and hydrogen gas.
 - (d) Lead (II) nitrate reacts with sodium sulphate to form lead (II) sulphate salt and sodium nitrate.

10.2 Balancing chemical equations

Activity 10.6

1. Put 1 kg mass on the left side of a weighing balance. Observe what happens.
2. Put some sand in a bag and place it on the right of the weighing balance. Observe what happens.



- Now, add sand into the bag until the beam balances.
- What can you conclude about the weights on both sides?
- Repeat the procedure, but this time, remove the sand on the right hand side. What happens?
- In pairs. Give reasons for the findings in the experiments above. How does this compare with balancing chemical equations? Discuss these with your friends in other pairs.
- Now, look at this equation:

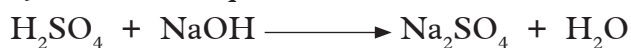

Study questions

- How many sodium atoms are there on the right hand side of the equation? What about the left hand side?
- How many hydrogen atoms are there on the right hand side? What about the left hand side?
- Compare the number of sulphur and oxygen atoms on both sides of the equation as well.
- Are the atoms on the right hand and left hand sides balanced?
- How can the imbalance be corrected?

Consider a mother of a family of seven siblings. She has seven cassavas and 6 cups of porridge. How would she be fair in giving this food to the family ensuring that everyone gets what is right and enough for them?

I have discovered that...

Balancing of chemical equations can be compared to distribution of resources in our everyday life. The available resources should be given out equitably so that everyone only gets what is enough and right for them. This in turn promotes peace in our families and in the entire community.

The facts

According to the law of conservation of matter, the total mass of the reactants in a chemical reaction is equal to the total mass of the products. Atoms are neither created nor can they be destroyed. They are only rearranged to form new substances. This means that, chemical equations must always be balanced. In order to balance an equation, whole numbers called **coefficients** are placed in front of the whole symbol/formula of substances in the equation. For the above equation, we can balance it as follows:

Step 1: Place 2 before NaOH



This balances Na atoms but causes O to get out of balance.

Step 2: We then place 2 before H₂O.



This balances both H and O atoms. If we now count the atoms of each of the elements, we find that all atoms are balanced. We can then say the equation has been **balanced**.

Finally, the physical states of reactants and products are placed to give:



This is a complete and balanced equation.

Such a balanced equation is also known as a **stoichiometric equation**. Balancing of chemical equations is similar to balancing equations of algebra in mathematics.

Note: Unbalanced chemical equations are unacceptable in Chemistry.

Activity 10.7

1. Work in pairs.
2. Go back to the previous text on balancing the equations between sulphuric acid (H₂SO₄) and sodium hydroxide (NaOH).
3. Read the text and try to come up with a list of rules.
4. Compare your list with the rules below.

Rules of balancing chemical equations

1. Write a word equation to show the reactants and products.
2. Write the correct symbol and formula under each reactant and each product.
3. Write the physical state of each substance after its symbol or formula.
4. Count the number of atoms of each element on the left-hand side of the equation (reactants) and on the right hand side (products). If the numbers of atoms of each element on each side of the equation are the same, then the equation is balanced.
5. If the numbers are not the same, then the chemical formulae must be multiplied by the lowest appropriate whole number in order to balance. Balance by placing coefficients (whole numbers) in front of the formulae. (**Note:** Do not change the actual formula).
6. The process of going through an equation from the left hand side to the right hand side, while ensuring that the number of each kind of atom on the reactants side equals the number of the same kind of atom on the products side is what we call balancing an equation.
7. Check the entire equation to ensure that all the atoms are balanced.
8. Make sure that the coefficients are in their lowest possible ratio.

Examples on the application of the rules

1. When metallic copper is heated in air, it reacts with oxygen to form copper (II) oxide. Write a balanced equation.

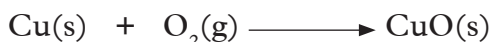

Since we have two atoms of oxygen on the left hand side, we place 2 before the formula of CuO.

Balancing the equation of the reaction between copper and oxygen.

The equation:



In the new equation, oxygen is balanced by putting 2 in front of CuO, but we have introduced 2Cu atoms. Therefore we place 2 in front of Cu on the left hand side as well. i.e.



Checking the equation, we realise that the number of each kind of atom on both sides of the equation are equal. Hence this is a **balanced equation**.

2. Balancing an equation for the reaction between sodium carbonate and dilute hydrochloric acid to form sodium chloride, carbon dioxide and water.

The equation is:



We note that there are two sodium atoms on the left hand side of the equation and one sodium atom on the right hand side of the equation. The hydrogen atoms are also not equal on both sides of the equation. We can balance this equation by placing 2 in front of NaCl to balance sodium i.e:



This balances sodium but causes Cl to go out of balance. We then place 2 in front of HCl i.e Chlorine.



This balances both Cl and H. If we count the number of each atom of the elements, we find that they are balanced. We can now add state symbols to get the equation.



Self evaluation Test 10.3

1. Balance these equations:



2. Balance the following chemical equations and put the state symbols.



The law of conservation of matter

A French scientist Antoine Laurent Lavoisier (1743 to 1794) observed that, the masses of reacting substances are the same as the masses of the products. He summarised this observation into the law of conservation of matter (mass); which states “**matter is neither created nor destroyed during a chemical reaction**”. Just as we have already learnt in a chemical reaction the numbers and kinds of atoms present in the products are the same as those present in the reactants. The only thing that changes is the states of the involved substances. This is the basis of **balancing chemical equations**.

Law of conservation of matter and chemical equations

A correctly written chemical equation representing a chemical reaction obeys the law of conservation of matter. The mass of all the reactants must be equal to the mass of all the products.

Consider the equation of burning carbon in oxygen below.



Notice that there is 1 carbon atom on the left (reactant) and 1 carbon atom on the right (product). There are 2 oxygen atoms in the reactant oxygen molecule and 2 in the product, carbon dioxide. Since the equation shows that the same number and kind of atoms are present after the reaction as were present before, we can conclude that indeed matter is conserved.

Self evaluation Test 10.4

- (a) State the law of conservation of matter.
(b) Describe an experiment, which can be used to verify the law of conservation of matter.
(c) How does the law of conservation of matter relate to balancing chemical equations?
- Write balanced chemical equations for the following reactions:
 - Calcium metal burns in oxygen to form calcium oxide.
 - Copper oxide powder reacts with warm dilute sulphuric acid to form copper (II) sulphate and water.
 - Lead (II) nitrate crystals are heated to form lead (II) oxide, nitrogen dioxide and oxygen.

(d) Barium chloride solution reacts with sodium sulphate solution to form barium sulphate precipitate and sodium chloride solution.

3. Balance the following chemical equations.

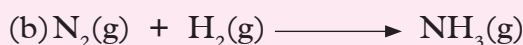
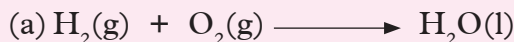

10.3 Interpreting and translating word equations into chemical equations

Activity 10.8

Discuss these questions in groups and make a report to present to the class.

1. Discuss about the prerequisite knowledge you need to translate a word equation into a chemical equation.
2. Discuss how to come up with correct formulae of compounds.
3. Write a report then let the secretary of your group present it to the rest of the class.

The Facts

With the knowledge of symbols of elements, radicals and their valencies, we can derive the correct formula of a compound.

In unit 5, we learnt about the valence of elements and radicals. We also learnt about the formulae of some chemical substances. The following table gives the valencies of common elements and radicals.

Table 10.1: Positively charged ions

Ion	Formula of ion	Valency
Lithium	Li^+	1
Sodium	Na^+	1
Potassium	K^+	1
Silver	Ag^+	1
Ammonium	NH_4^+	1
Hydrogen	H^+	1

Magnesium	Mg ²⁺	2
Calcium	Ca ²⁺	2
Lead (II)	Pb ²⁺	2
Zinc	Zn ²⁺	2
Iron (II)	Fe ²⁺	2
Copper (II)	Cu ²⁺	2
Aluminium	Al ³⁺	3
Iron (III)	Fe ³⁺	3

Table 10.2: Negatively charged ions

Ion	Formula of ion	Valency
Fluoride	F ⁻	1
Chloride	Cl ⁻	1
Bromide	Br ⁻	1
Hydroxyl	OH ⁻	1
Nitrate	NO ₃ ⁻	1
Nitrite	NO ₂ ⁻	1
Hydrogen carbonate	HCO ₃ ⁻	1
Oxide	O ²⁻	2
Sulphide	S ²⁻	2
Sulphate	SO ₄ ²⁻	2
Carbonate	CO ₃ ²⁻	2
Nitride	N ³⁻	3
Phosphate	PO ₄ ³⁻	3

Steps in deriving the chemical formulae of compounds

One can derive the correct formula of a compound using two methods:

- (a) Balancing of charges
- (b) Interchanging valencies

(a) Balancing charges

Step 1

From the name of the compound, you know the ions that make the compound.

Write the formula of the ions below the name. For example,

Sodium
Na⁺

Sulphate
SO₄²⁻

Zinc
Zn²⁺

Nitrate
NO₃⁻

Step 2

The sum of the charges of the ions in the ionic compound must be equal to zero since ionic compounds are neutral (they have no charge). To enable this, determine the least common multiple (L.C.M) of the charges of the ions.

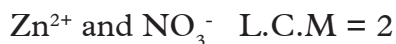
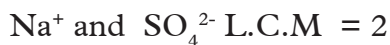

Step 3

Determine a scalar which when we multiply by the charges we obtain the L.C.M. The scalars are used as subscripts after the symbol of each element or radical. If the radical has a scalar other than 1, introduce brackets then write it outside the brackets.

From the above examples, the formula for sodium sulphate will be Na_2SO_4 .

And for Zinc nitrate will be $\text{Zn}(\text{NO}_3)_2$

Notice how we represent the nitrate ion in the formula $\text{Zn}(\text{NO}_3)_2$ as compared to SO_4 in the formula Na_2SO_4 . Why is this so?

Examples

Formula of Lithium oxide will be

Step 1



Step 2



Balanced charges



Step 3

Formula



Formula of Sodium Phosphate will be

Step 1

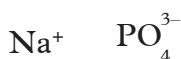

Step 2



Balanced charges



Step 3

Formula



Formula of magnesium nitrate will be

Step 1



Step 2



Balanced charges



Step 3 Formula
 Mg (NO₃)₂

(b) Interchanging valencies

We can also derive correct formulae by interchanging the valencies and using them as subscripts below the symbols of each element. Look at the following example:

(i) Calcium chloride

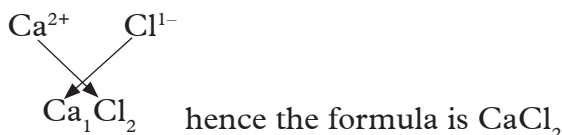

(ii) Aluminium sulphate

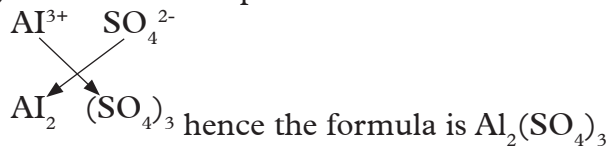

(iii) Sodium carbonate

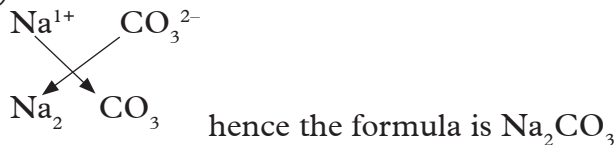

This knowledge helps us to interpret word equations and transform them into chemical equations. Then we balance them.

Converting word equations into chemical equations

Examples

1. Sodium hydroxide + Nitric acid \longrightarrow Sodium nitrate + water



The equation is balanced.

2. Nitrogen + hydrogen \longrightarrow ammonia



3. Sodium + chlorine \longrightarrow sodium chloride



4. Calcium + water \longrightarrow calcium hydroxide + hydrogen



Converting chemical equations into word equations

By interpreting chemical equations, you can convert them into word equations. For example:

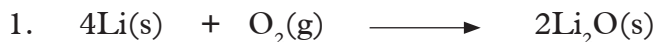

Lithium + oxygen \longrightarrow Lithium oxide



Sodium + water \longrightarrow sodium hydroxide + hydrogen

Remember the facts...

- A chemical equation is the symbolic representation of a chemical reaction in the form of symbols and formulae.
- Chemical reactions can be represented using either word equations or chemical equations.
- Knowledge of valences of elements and radicals is useful in deriving the correct formulae of compounds when writing chemical equations from word equations.
- In a chemical reaction, the substances that exist before the reaction are reactants while those formed during the reaction are products.
- A chemical equation is written so that the reactants are on the left-hand-side of the arrow while the products are on the right hand side of the arrow. If there is more than one reactant, the different reactants are separated by plus signs. The same is true when there is more than one product.
- The law of conservation of matter states, "Matter is neither created nor destroyed".
- Balancing chemical equations is a way of obeying the law of conservation of matter in chemical reactions.
- A word equation can be interpreted and translated into a chemical equation and vice versa.
- Correctly written chemical equations must have correct chemical symbols, they must be balanced and they must have correct state symbols.

Test Your Competence 10

- Write word equations for the following reactions.
 - Carbon burning in excess oxygen to form carbon dioxide.
 - Hydrogen reacting with oxygen at high temperature to form steam.
 - Sodium hydroxide solution reacting with dilute sulphuric acid to form sodium sulphate and water.
 - Methane reacting with oxygen gas to form carbon dioxide and water.
- Convert the following word equations into symbolic chemical equations.
 - Nitrogen + hydrogen \longrightarrow ammonia
 - Sulphur + oxygen \longrightarrow sulphur dioxide
 - Sulphur + iron \longrightarrow iron (II) sulphide
- Balance the following chemical equations.
 - $\text{Li (s)} + \text{O}_2(\text{g}) \longrightarrow \text{Li}_2\text{O(s)}$
 - $\text{Mg(s)} + \text{HNO}_3(\text{aq}) \longrightarrow \text{Mg (NO}_3)_2(\text{aq}) + \text{H}_2(\text{g})$
 - $\text{Zn (NO}_3)_2(\text{s}) \xrightarrow{\text{heat}} \text{ZnO (s)} + \text{NO}_2(\text{g}) + \text{O}_2(\text{g})$
 - $\text{Cl}_2(\text{g}) + \text{KOH (aq)} \longrightarrow \text{KCl(aq)} + \text{KClO}_3(\text{aq}) + \text{H}_2\text{O (l)}$
 - $\text{Al(s)} + \text{HCl(aq)} \longrightarrow \text{AlCl}_3(\text{aq}) + \text{H}_2(\text{g})$
 - $\text{FeCl}_2(\text{aq}) + \text{Cl}_2(\text{g}) \longrightarrow \text{FeCl}_3(\text{aq})$
- Translate the following chemical equations into word equations.
 - $2\text{Na(s)} + \text{Cl}_2(\text{g}) \longrightarrow 2\text{NaCl(s)}$
 - $\text{CaCO}_3(\text{s}) + 2\text{HNO}_3(\text{aq}) \longrightarrow \text{Ca (NO}_3)_2(\text{aq}) + \text{CO}_2(\text{g}) + \text{H}_2\text{O(l)}$
 - $\text{Zn(s)} + 2\text{HCl (aq)} \longrightarrow \text{ZnCl}_2(\text{aq}) + \text{H}_2(\text{g})$
 - $\text{Fe(s)} + \text{CuSO}_4(\text{aq}) \longrightarrow \text{FeSO}_4(\text{aq}) + \text{Cu(s)}$
- Write balanced chemical equations for the following reactions:
 - Calcium metal burns in oxygen to form calcium oxide.
 - Copper oxide powder reacts with warm dilute sulphuric acid to form copper (II) sulphate and water.
 - Lead (II) nitrate crystals are heated to form lead (II) oxide, nitrogen dioxide and oxygen.
 - Barium chloride solution reacts with sodium sulphate solution to form barium sulphate precipitate and sodium chloride solution.
- Show the chemical formulae of the following compounds using:
 - Balancing of charges
 - Interchanging of valencies
 - Aluminum chloride
 - Sodium nitrate
 - Magnesium hydrogen carbonate
 - Zinc nitrate

Most of the substances we use in our homes and at school contain acids and bases. For example, the car battery contains **sulphuric acid**. Drugs like antacids used to treat stomach acidity and bleaches used to clean surfaces contain **bases**.

In Agriculture, we use acids and bases to treat soils while in Biology, things like gastric juice, blood, urine and body fluids contain acids and bases. Fruits like lemon and oranges also contain acids.

This unit is therefore very significant to our lives. There is need to understand how these chemicals work, the dangers associated with them and how to dispose of things made of or containing acids without destroying the environment.

Key unit competency

After studying this unit, I should be able to extract indicators from flowers and use them to test the observable properties of acids and bases in common domestic substances.

Unit outline

- 11.1 Definition of an acid, a base and an alkali
- 11.2 Properties of acids and alkalis
- 11.3 Simple acid-base indicators
- 11.4 pH of solution
- 11.5 Applications of acids and bases
- 11.6 Dangers associated with acids and bases

11.1 Definition of an acid, base and an alkali

Activity 11.1

In pairs, discuss the following questions

1. Some people take wood ash when they have heartburn. How does it help?
2. Why should we brush our teeth at least twice a day using a tooth brush and tooth paste?
3. Your teacher will provide you with portions of orange and lemon fruits. You will be required to eat them and describe their tastes.

I have discovered that...

The sour taste in some of the foodstuffs we eat is due to certain substances they contain. These substances are known as acids. Sometimes the acids in the stomach may cause inflammation of the gullet. This condition can be treated by taking in certain substances.

These substances neutralise the effect of acids. They therefore can be used to suppress the effects of excess acids. These substances are known as bases. Toothpaste contains basic substances that suppress acids. Such acids result from food particles trapped in teeth which can cause cavities.

The Facts

An acid is a substance which when dissolved in water dissociates to give hydrogen ion(s) (H^+) as the only positively charged ions.

Examples of acids and the ions they produce on dissociation include:

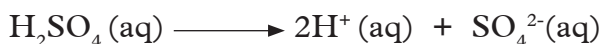

The hydrogen ion (H^+) gives acids their characteristic properties.

Acids can either be commercial or natural.

Commercial acids are bought from shops or chemical outlets.

Examples of commercial acids include hydrochloric acid (HCl), sulphuric acid (H_2SO_4) and nitric acid (HNO_3). Natural acids are found in a variety of things as shown in the table below.

Table 11.1 Sources of natural acids

Natural acid	Source
Citric acid	Orange and lemon
Acetic acid	vinegar
Formic acid	venom of bee and ant stings
Lactic acid	Milk.
Malic acid	Apples, grapes
Oleic acid	Olive oil
Oxalic acid	Tomato
Glycolic acid	Sugarcane, apples

Note: Hydrochloric acid is also found naturally in our stomachs.

Gases like carbon dioxide, hydrogen chloride and chlorine also show acidic properties when dissolved in water.

A base is a substance which when dissolved in water dissociates to give hydroxide ions (OH^-) as the only negatively charged ions.

Examples of bases include $NaOH$, KOH and $Ca(OH)_2$. On dissociation these bases give the following ions:



The hydroxide ion (OH^-) gives bases their characteristic properties. A base that dissolves in water is called an **alkali**.

11.2 Properties of Acids and Alkalis

a) Properties of acids

Activity 11.2

Experiment to determine properties of acids

Apparatus and reagents

Dilute hydrochloric acid, litmus paper (blue and red), oranges, vinegar, lemon, paper, concentrated sulphuric acid, test tubes, magnesium ribbon, sour milk and nitric acid.

Procedure

1. Taste these substances and record your observations in a table.

Substance	Taste (bitter, sour)
Sour milk	
Oranges	
Vinegar	
Lemon	

2. Drop a piece of magnesium ribbon into a test tube containing dilute hydrochloric acid. Write down what you observe.
3. Place some concentrated sulphuric acid in a test tube. Drop a piece of paper in the acid. Record your observations.
4. Drop blue and red litmus papers in dilute hydrochloric acid contained in a test tube. What do you observe?
5. Add phenolphthalein and methyl orange indicators to nitric acid in different test tubes. What do you observe?

I have discovered that...

Oranges, lemon, vinegar and sour milk all have sour taste. Citric acid in oranges and lemon make them sour while acetic acid and lactic acid in vinegar and milk respectively, make them sour.

The facts

The following are properties of acids:

1. Acids have **sour** taste.
2. Acids turn blue litmus paper red.
3. A piece of paper placed in concentrated sulphuric acid gets charred. This is because acids are **corrosive**.
4. When magnesium ribbon is dropped in dilute hydrochloric acid, bubbles of a colourless gas are seen. This shows that dilute acids react with metals to produce hydrogen gas as one of the products.

b) Properties of alkalis

Activity 11.3

To determine properties of bases

Apparatus and reagents

Test tubes, droppers, sodium hydroxide solution, dilute hydrochloric acid, litmus papers, phenolphthalein indicator, methyl orange indicator.

Procedure

1. Add pieces of litmus paper to sodium hydroxide solution. Record your observations.
2. Add two drops of phenolphthalein to 2 cm³ of dilute sodium hydroxide solution. Record your observation. Repeat this experiment using methyl orange in place of phenolphthalein. Record your observations.
3. Add equal volumes of sodium hydroxide and hydrochloric acid in the same test tube. Test the resulting solution with red and blue litmus papers. What do you observe?

I have discovered that...

Red litmus papers turn blue when put in sodium hydroxide solution. Phenolphthalein indicator turns from colourless to pink when added into sodium hydroxide solution. Methyl orange turns yellow when added into sodium hydroxide solution.

The solution formed when equal volumes of sodium hydroxide and hydrochloric acid are mixed together has no effect on blue and red litmus papers. It is a neutral solution.

The facts

The following are properties of alkali:

1. Alkalis have a bitter taste.
2. Alkalis have a soapy feel.
3. Alkalis turn red litmus paper blue, methyl orange indicator yellow, and phenolphthalein indicator pink.

Activity 11.4

Your teacher will bring a variety of substances for you to test.

1. Take one thing at time and taste. Record your observations.
2. Dip blue and red litmus papers in the solutions of the substances provided. Write your observations.

Substance	Blue litmus	Red litmus
A		
B		
C		
D		

3. Add phenolphthalein indicator and methyl orange indicator to two separate solutions of each substance. Write down your observations.
4. Based on the results of these experiments. Group the substances as either acids or bases. Do a presentation to the rest of the class.

Table 11.2 Summary of properties of acids and bases

Acids	Bases
Have sour taste.	Have bitter taste and soapy feel.
Are corrosive.	Are corrosive.
Turn blue litmus red.	Turn red litmus blue.
React with bases to form salt and water only.	React with acids to form salt and water only.

Examples of acids are:

- (i) Commercial acids - sulphuric acid, hydrochloric acid and nitric acid.
- (ii) Natural acids - Acetic acid, lactic acid and citric acid.

Examples of soluble bases (alkali) are:

Sodium hydroxide, barium hydroxide, potassium hydroxide among others.

Self-evaluation Test 11.1

1. (a) Distinguish between an acid and an alkali.
(b) Hydrochloric acid is naturally found in the stomach. What role does it play in the stomach?
2. Fill the table below appropriately with any of these words: natural, commercial, both natural and commercial.

Acid	Type
Acetic acid	
Hydrochloric acid	
Sulphuric acid	
Ethanoic acid	
Nitric acid	

3. Given the following list of some house hold products, classify them into either acids or bases. Yorghut, pineapple, toothpaste, limewater, limejuice and baking soda.

11.3 Simple acid–base indicators

Given two solutions labeled A and B whereby one is an acid and the other a base, how can you differentiate between the two?

In Chemistry, it is difficult to tell if a substance contains an acid or a base and to what level except for the foodstuffs that we can consume. This then means that we

must have another substance that we can use to test if a substance is a base or an acid. Such a substance is known as an **indicator**.

Activity 11.5

1. In pairs discuss the meaning of the word 'indicator'.
2. Discuss the meaning of the different colours produced by lights that guide motorists and pedestrians in busy towns.
3. Why are the colours different?
4. How can we apply this knowledge to differentiate between acids and bases?
5. Now research from reference materials the meaning of acid-base indicators.

I have discovered that...

An acid-base indicator is a substance, which shows one colour when in an acidic solution and a different colour when in a basic solution. Therefore an indicator can be used to classify substances as either acids or bases.

The Facts

Indicators can be classified as either naturally occurring or commercial indicators. The most common commercial indicator is **litmus**. Litmus is a blue vegetable compound, which is extracted from lichens. Litmus shows a blue colour in an alkali and a red colour in an acid.

Other commonly used commercial indicators are phenolphthalein and methyl orange.

Many other plant materials contain dyes which can be used as acid-base indicators. Examples are leaves of red cabbages, coloured flower petals of hibiscus or bougainvillea among others. They show one colour in an acidic solution and another different colour in an alkaline solution.

Activity 11.6

Experiment to prepare an acid-base indicator from red cabbages

Apparatus and reagents

Red cabbage leaves, filter funnel, conical flask, test tubes, beaker, tapwater, filter paper, mortar and pestle, hydrochloric acid, potassium hydroxide, dilute sulphuric acid and boiling water.

Procedure

1. Cut off two leaves of red cabbage into tiny pieces.
2. Crush the tiny pieces of red cabbage leaves in mortar using the pestle. Add boiling water as you continue crushing. This helps to extract as much dye from the leaves as possible.
3. Allow the small pieces of red cabbage leaves to stand in the water until it

becomes purple coloured. This may take an hour. Transfer the contents into a beaker.

4. Filter the mixture into a clean conical flask. What is the colour of the filtrate?

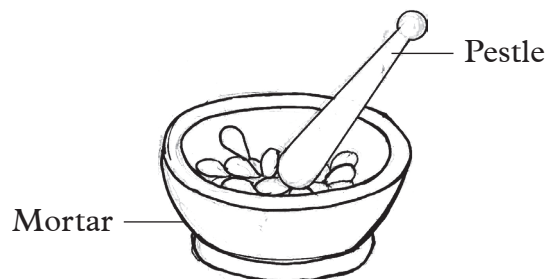

Fig 11.1: Mortar and pestle

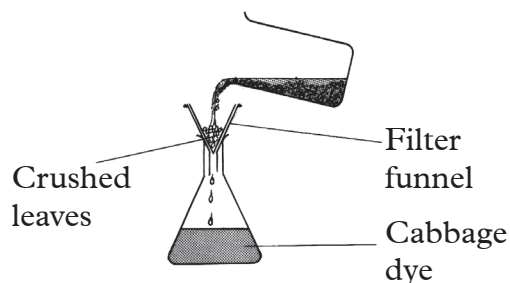

Fig 11.2: Filtration

5. Add three drops of the red cabbage extract into five test tubes containing water, hydrochloric acid, sodium hydroxide, potassium hydroxide and dilute sulphuric acid. Record your observations.

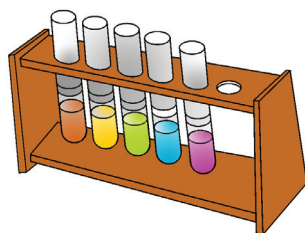

Fig 11.3: Test tube rack

6. Classify the solutions in the test tubes as acidic, basic or neutral. Summarise your results in the following table.

Substance	Colour of red cabbage extract in the substance.	State whether acid, base or neutral
Water		
Hydrochloric acid		
Sodium hydroxide		
Potassium hydroxide		
Dilute sulphuric acid		

Discussion corner!

1. Why do we cut the red cabbage leaves into small pieces?
2. What is the role of boiled water in this experiment?
3. What is the colour of the cabbage extract?
4. How can you make the extracted indicator solution more concentrated?

I have discovered that...

We cut the red cabbage leaves into small pieces in order to make it easy to extract the juice. The boiled water is the solvent that dissolves the dye in the red cabbage. The dye in the red cabbage dissolves in water making it to turn purple. The purple colour is pale. The solution can be concentrated by evaporating some of the water during which we obtain a laboratory-made indicator. When tested, the indicator made is purple in water. Dilute hydrochloric acid and dilute sulphuric acid, turn the indicator to orange whereas in sodium hydroxide and potassium hydroxide it turns green. Using this laboratory made indicator, it is clear that water is a neutral substance. That is why it has no effect on the indicator. Dilute hydrochloric acid and dilute sulphuric acid are acidic whereas sodium hydroxide and potassium hydroxide solutions are basic or alkalis.

The Facts

The composition of these laboratory made indicators keep changing with time. This causes the colour of the extract to change also. Therefore, a mixture of these indicators with acid or base also changes colour with time. Plant extracts therefore give inconsistent results when used as acid-base indicators. Red cabbage leaves or flower extracts should hence be used when still fresh. Other coloured parts of plants such as beetroots can also be used to make similar indicators.

In the laboratory, commercial indicators that give more consistent results are commonly used as acid-base indicators.

Commercial indicators include litmus, methyl orange, phenolphthalein and screened methyl orange. They are manufactured for sale by various chemical producing companies and supplied to laboratories for use. Unlike laboratory-made indicators, commercial indicators can be used over a long period of time and still give consistent results.

Activity 11.7

Experiment to determine colour changes in indicators

Apparatus and reagents

All the commercial indicators available, test tubes, dilute hydrochloric acid, orange juice, dilute sulphuric acid, sodium hydroxide solution, potassium hydroxide solution, water, ammonia solution and soap solution.

Procedure

1. To four separate test tubes, add 1 cm³ of dilute hydrochloric acid.
2. To the first test tube, add 2 drops of the litmus solution. To the second test tube, add 2 drops of phenolphthalein indicator. To the third and fourth test tubes, add 2 drops of methyl orange and screened methyl orange respectively.

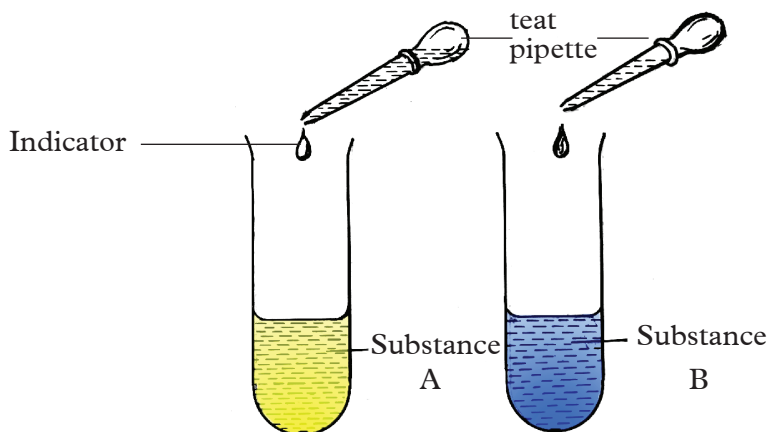

Fig 11.4: Identifying substances using indicators

- Record your observations in a table.
- Repeat the experiment using soap solution, orange juice, sulphuric acid, sodium hydroxide, potassium hydroxide, water and ammonia solution; instead of hydrochloric acid. Record your results in a table.

Discussion corner!

- What is the colour of each indicator in:
 - Acidic solution?
 - Alkali?
 - Neutral solution?
- Write a report and present it to the class.

I have discovered that...

Table 11.2: Colours of different solutions in different indicators

Indicator Solution Tested	Litmus Solution	Phenolphthalein	Methyl Orange	Screened Methyl Orange
Hydrochloric acid	Red	Colourless	Pink	Purple
Sulphuric acid	Red	Colourless	Pink	Purple
Sodium hydroxide	Blue	Pink	Yellow	Orange
Potassium hydroxide	Blue	Pink	Yellow	Orange
Water	Purple	Colourless	Orange	Grey
Ammonia solution	Blue	Pink	Yellow	Orange

Self-evaluation Test 11.2

- Describe how you would prepare an indicator in the laboratory from hibiscus flowers.

- (a) Name three commercial indicators commonly found in the laboratory.
(b) State the colour changes of the indicators named in 2 (a) in acidic, basic and neutral solutions.
- Why do you think the knowledge of acidity levels in substances is important?

11.4 The pH of a solution

Activity 11.8

Research activity

- While at home, what are some of the things you use in the cultivation of crops to ensure an abundant harvest?
- Why do we add slaked lime or gypsum to certain soils?
- What are the effects of adding slaked lime, gypsum, to the soil?
- Why is it important to take samples of soil to the laboratory for testing before a farmer begins cultivation?

I have discovered that...

Soil testing is important as it enables farmers to determine the soil pH. This helps them make the right choice of the crop to plant.

The Facts

After cultivation, appropriate measures are taken, such as addition of lime so as to lower acid levels or addition of gypsum to increase acidity of the soil. The pH of a solution is a measure of the acidity or alkalinity of the solution.

Activity 11.9

Experiment to determine pH of different substances

Apparatus and reagents

Dilute hydrochloric acid, dilute sulphuric acid, sodium hydroxide solution, distilled water, ammonia solution, calcium hydroxide, lemon juice, rainwater, test tubes, universal indicator, pH scale and droppers.

Procedure

- Place 1 cm³ portions of dilute hydrochloric acid, dilute sulphuric acid, sodium hydroxide solution, ammonia solution, calcium hydroxide, distilled water, lemon juice and rainwater into different test tubes.
- To each test tube, add 3 drops of the universal indicator and observe the colour of the solution.

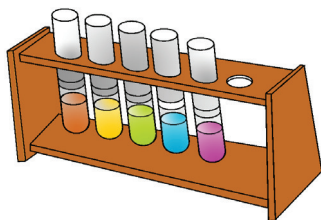

Fig 11.5: Test tubes containing different solutions

- Place each test tube and its contents against a pH chart. Match the colour of the indicator in the solution against the shade on the pH chart and record the pH value of each solution in a table.

Solution	Colour of universal indicator in the solution	pH value
Hydrochloric acid		
Sulphuric acid		
Sodium hydroxide		
Distilled water		
Ammonia solution		
Calcium hydroxide		
Rain water		
Lemon juice		

I have discovered that...

The pH values for acids range from zero to just below seven. Substances such as rainwater and lemon juice are considered acidic and have pH values, which range between 4 and 7. They are said to be **weak acids**. Solutions of hydrochloric acid and sulphuric acid have pH values, which range between 0 and 4. These solutions are said to be **strong acids**. As the pH values decrease from 7 to 0, the strength of acids increases.

A pH value of 7 implies the solution is neither acidic nor basic and it is hence said to be **neutral**. Distilled water is neutral hence has a pH of 7. The pH values of bases range between 7 and 14. Ammonia solution and calcium hydroxide solution have pH values between 7 and 10 and are said to be **weak bases**. An example of a naturally occurring weak base is a wood ash. Sodium hydroxide and potassium hydroxide solutions have pH values above 10 and are said to be **strong bases**. As the pH values increase from 7 to 14, the strength of the bases also increases.

The Facts

The universal indicator is a mixture of several indicators and it shows a range of colours in acids and bases depending on the degree of acidity or alkalinity. Some acids are more acidic than others while some bases are more basic than others.

By use of a universal indicator and the pH chart, we can get the pH values of various solutions.

Quality check!

Before buying universal indicators to be used in the laboratory always check to confirm that they meet the standards.

The pH scale

The pH scale measures how acidic or basic a substance is. It has numbers ranging from 0 to 14. A pH of 7 shows that a solution is neutral while a pH below 7 shows that a solution is acidic. A pH higher than 7 indicates that a solution is basic.

Example of a standard pH colour chart

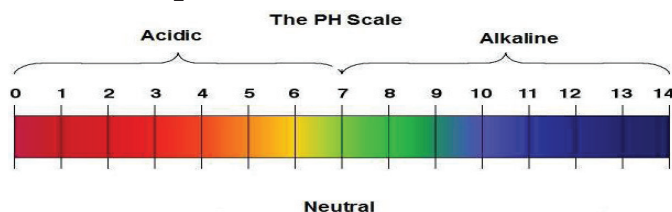

Self-evaluation Test 11.3

What is the approximate pH of the following substances: mineral water, distilled water, sour milk, milk of magnesium, soap solution, baking powder solution and tooth paste solution?

Using a pH-meter

Activity 11.10

Your teacher will bring a pH meter in class for you to observe.

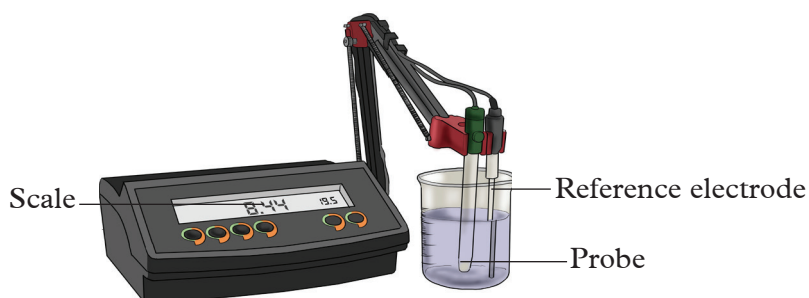

Fig 11.6: A pH metre

1. Observe the pH meter carefully. (Be careful not to break the apparatus)
2. Compare it to the chart given by your teacher.
3. Draw and label the various parts.
4. Use the pH meter to determine the pH of the solutions provided by the teacher.
5. Use the readings to group the solutions as strong or weak acids and bases.

The Facts

A pH meter is used to make rapid and accurate measurements of pH of various solutions. A pH meter is made up of two electrodes one of which is the **reference electrode** connected to a multi-voltmeter and the second one called the **probe**. Both are dipped into the solution being tested. The result is directly converted into pH and shown on the screen. The electrodes have to be rinsed in distilled water before being dipped into another solution of unknown pH for testing.

pH meters are usually used in hospitals to determine pH of blood and urine samples for diagnostic purposes.

11.5 Applications of acids and bases

Activity: 11.11

1. Look at the pictures below.

A.

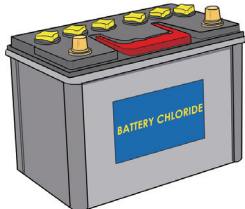

B.



C.



2. Name the things in the pictures and state what they are used for. Prepare a report for presentation to the rest of the class.
3. State some of the applications of acids and bases in our daily lives.

The Facts

Some applications of acids

1. Hydrochloric acid is produced in the human stomach. It is used to aid in the process of digestion.
2. Sulphuric acid is used in car batteries, manufacture of plastics, pesticides, detergents and pharmaceutical products. It is also used in the manufacturing of some fertilisers.
3. Ethanoic acid in vinegar is used as a food seasoning.
4. Carbonic acid is added in soft drinks to enhance taste.
5. Nitric acid is used in the manufacture of nitrogenous fertilisers, explosives and in the manufacture of dyes and paints.
6. Phosphoric acid is used in the manufacture of phosphate fertilisers and making anti-rust paint.
7. Methanoic acid is used in kettle de-scalers.

Some applications of bases

1. Ammonia solution is used in the manufacture of fertilisers and detergents.
2. Sodium hydroxide is used in the manufacture of soaps and detergents.
3. Ammonium hydroxide is used to make cleaning agents such as oven cleaners.
4. Magnesium hydroxide is used in the treatment of indigestion.
5. Calcium hydroxide is used as garden lime to reduce soil acidity and in the manufacture of cement and toothpaste.

Quality check!

I will ensure that I buy only standard materials made of acids and bases. This way, I will avoid risks associated with sub-standard materials and save on costs!

11.6 Dangers associated with bases and acids

The Facts

Acids and bases cause a number of undesirable effects on the environment.

1. Acid rain

Industrial processes release acidic gases into the atmosphere. When gases, such as sulphur dioxide and nitrogen dioxide, accumulate in the atmosphere, they combine with rainwater to form what is called acid rain. Acid rain causes a number of environmental problems.

- It wears off buildings and structures made of limestone. Acids also rapidly corrode buildings made of metal.
- When surface run off resulting from acid rain adds to lakes and rivers, it kills aquatic animals and plants.
- Acid rain causes nutrients to be leached out of the soil and from leaves. Trees are thus deprived of these nutrients.
- Due to the rain, aluminium ions are freed from clays as aluminium sulphate resulting in damaged tree roots. The trees are unable to draw enough water through the damaged roots leading to death.

My environment, my life!

Let us champion against release of harmful gases to the atmosphere. This will reduce air pollution and even chances of global warming!

2. Tooth decay

Bacteria change foods that stick between teeth into acids. These acids dissolve the enamel leading to tooth decay; this eventually causes toothaches. Tooth decay begins when the pH in the mouth falls below 5.

Note: Toothpastes are alkaline in order to neutralise acids in the mouth.

Health Check!

Let us brush our teeth at least twice a day to keep healthy!

3. Stomach indigestion

Dilute hydrochloric acid in our stomach helps in digestion of food. However when the stomach secretes excess of the acid, it causes indigestion. The acid burns the lining of the stomach hence causing ulcers.

Note: Antacid tablets contain mild base i.e magnesium hydroxide. This neutralises excess acidity in the stomach hence relieving pain.

Quality check!

Before you buy any medicine from the pharmacy ensure that it has not expired.

4. Soil pH

Plant growth is affected by the acidity or alkalinity of the soil. The degree of acidity depends on the concentration of hydrogen ions (H^+) in the soil solution. When the concentration of the ions is very high, the soil is said to be acidic and it is very low then the soil is termed as basic. Soil acidity is also affected by excess use of fertilisers and acid rain. Acidic soil is unsuitable for growth of certain crops.

Note: If the soil is too acidic, it is treated by addition of lime. Lime base is a mixture of calcium oxide and calcium hydroxide, which neutralises excess acidity in the soil.

Self-evaluation Test 11.4

1. (a) What is pH of a solution?
(b) The following table gives pH of some solutions.

Solution	pH center
A	3.0
B	5.2
C	5.0
D	11.0
E	12.5
F	7.0

Identify the substances that are acids and those that are bases.

- (c) Which solution:
- Is the most basic?
 - Is the most acidic?
 - Will not affect universal indicators?
 - Is likely to be found in human stomach?

2. State whether **true** or **false**
 - (a) pH is a measure of hydroxide ion (OH^-) concentration in a solution.
 - (b) Universal indicator is a mixture of several indicators.
 - (c) Strong acids have pH between 4-7.
 - (d) Weak bases have pH between 8-10.
 - (e) pH meter is the same as pH chart.
3. State the uses of the following acids and bases.
 - (a) Ethanoic acid
 - (b) Sulphuric acid
 - (c) Sodium hydroxide
 - (d) Ammonium hydroxide
4. Ammonium hydroxide is a base that is found in window cleaner. What precaution must you observe before using this product?

Remember the facts...

- An acid is a substance that when dissolved in water produces hydrogen ions (H^+).
- A base is a substance which when dissolved in water produces hydroxide ions (OH^-).
- Alkalis are soluble bases.
- Acids have specific properties, which are different from those of alkalis.
- Indicators are used to differentiate acids from bases.
- Indicators can be extracted from natural materials such as coloured flowers and leaves.
- Indicators such as litmus solution, phenolphthalein and methyl orange are commercial indicators found in the laboratory.
- Universal indicator is a mixture of indicators. It is used together with the pH chart to approximate pH values of solutions.
- A pH meter can also be used to directly and accurately get the pH values of solutions.
- Acids and bases have various applications in our daily lives.
- We should be conscious of the dangers associated with acids and bases.

Test Your Competence 11

1. What is an indicator?
2. Kana owns a factory that releases a lot of smoke to the atmosphere.
 - (a) What are the environmental effects of this?
 - (b) What advice can you give to Kana?
3. Give the missing information in the table below.

Indicator	Colour in Acid	Colour in alkali
Methyl orange	red	
	red	blue
		pink

4. State whether each of the statements below is either **true** or **false**.
 - (a) Alkalis have a slippery feel.
 - (b) Alkalis are corrosive.
 - (c) Alkalis react with acids to form salt, a gas and water.
 - (d) Alkalis have a sour taste.
5. A bee sting contains methanoic acid. That is why it is so painful. How then can you treat someone who has been stung by a bee?
6. Which ions are responsible for:
 - (a) Acidic properties?
 - (b) Basic properties?
7. A seed catalogue states the preferred soil pH ranges for plants as follows.

Type of plant	Preferred pH range
Heather	4.5 – 6.0
Violet	5.0 – 7.5
Primrose	5.5 – 6.5
Daffodil	6.0 – 6.5

- (a) Which plant will grow over the largest pH range? (Show how you arrived at your Answer)
- (b) At which soil pH will a gardener be able to grow all of these plants?
- (c) Which of the plants can be grown in an alkaline soil? Explain.
- (d) The soil in a garden has a pH of 4.5. Explain how a gardener can treat the soil in order to grow daffodils.

UNIT 12

Inorganic Salts and their Properties

You are already familiar with table salt. What is the importance of table salt? Did you know that many other substances also contain salts? For example, have you ever seen animal feeds such as rabbit pellets, calf licks and chicken mashes? Did you know that they contain various types of salts? Now look at the pictures below. Can you identify them?



Fig 12.1 Some substances made of salt

What would you say is the difference between salt and sugar? What is the difference in their functions?

Clearly, salts play an important role in our lives. You should therefore be more keen when handling this unit as it will equip you with lifelong skills.

Health check!

Always ensure you consume food prepared with iodised table salt to prevent goitre.

Key unit competency

After studying this unit, I should be able to analyse properties of different types of salts.

Unit outline

- 12.1 Definition and nomenclature of salts
- 12.2 Physical properties of inorganic salts
- 12.3 Action of heat on salts

12.1 Definition and nomenclature of salts

Activity 12.1

Discuss the questions below and write a report for presentation to the class. You can do research in the library or through the Internet. You can also use handouts and pamphlets provided by your teacher.

1. What do you understand by the term salt?

- Name any five salts that you know.
- Salts are named depending on the acid they are derived from. Considering this fact, give the missing information in the following table.

Acid	Base	Name of the resultant salt
Hydrochloric acid	NaOH	
Sulphuric acid	KOH	
Carbonic acid	Ca(OH) ₂	
Nitric acid	Mg(OH) ₂	

- Write the formulae of the following salts.

Salt	Formula
Potassium nitrate	
Sodium chloride	
Calcium sulphate	
Zinc chloride	
Potassium chloride	
Sodium sulphate	

The Facts

A salt is a compound formed when the hydrogen ions of an acid are wholly or partially replaced by a metal or ammonium ion. The process involves a **neutralisation** reaction in which a base neutralises an acid.

When all the hydrogen ions of an acid are replaced by a metal or ammonium radical, we get a **normal salt**. All chloride and nitrate salts are normal salts. When the hydrogen ions of an acid are partially replaced, we obtain an **acid salt**.

The number of hydrogen atoms in each molecule of an acid, replaceable directly or indirectly by a metal or ammonium radical, is called the **basicity** of that acid. Both hydrochloric and nitric acids contain only one replaceable hydrogen atom hence are said to be **monobasic**. Monobasic acids form one series of salts i.e normal salts.

Sulphuric and carbonic acids have two replaceable hydrogen atoms per molecule of the acid. They are **dibasic**. These acids form two series of salts.

(i) Where all hydrogen atoms of the acid are replaced i.e, normal salt.

Consider the following illustrations.

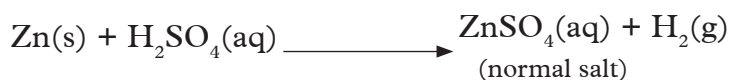

Note that zinc sulphate has no hydrogen atom which can be replaced. It is therefore described as a **normal salt**.

(ii) Where only a part of the hydrogen atoms of the acid are replaced i.e, acid salt.
Consider the following illustrations.



Note that sodium hydrogen sulphate salt still has one hydrogen atom, which can be replaced by a metal or ammonium ion. This is why it is known as an acid salt.

Names of salts are derived from the metal or ammonium ion from which they are formed and the parent acid. When naming salts the name starts with the metal or ammonium ion in the salt, followed by the respective acid radical.

Table 12.1 Naming of salts from different acids

Acid and its formula	Class of salt	Type of salt	Examples
Hydrochloric acid (HCl)	Chlorides	Normal	Sodium Chloride Calcium Chloride
Nitric acid (HNO ₃)	Nitrates	Normal	Potassium nitrate Lead(II) nitrate
Sulphuric acid (H ₂ SO ₄)	Sulphates	Normal	Magnesium sulphate Lithium Sulphate
	Hydrogen sulphates	Acid	Sodium hydrogen sulphate
Carbonic acid (H ₂ CO ₃)	Carbonates	Normal	Zinc carbonate Calcium carbonate
	Hydrogen carbonates	Acid	Calcium hydrogen Carbonate

Self-evaluation Test 12.1

1. Define the term tribasic salt

Match the acid with the salt name associated with it.

Acid	General name of the salts
Nitric acid	Chlorides
Hydrochloric acid	Sulphates
Carbonic acid	Nitrates
Sulphuric acid	Carbonates

2. State whether these acids form normal salts only or can form both normal and acid salts.

- (a) Carbonic acid (b) Hydrochloric acid
(c) Sulphuric acid (d) Nitric acid

3. Give the names of salts formed when:
- Sodium metal replaces hydrogen ions of nitric acid.
 - Calcium metal partially replaces hydrogen ion of carbonic acid.
 - Ammonium ion replaces the hydrogen ions of hydrochloric acid.
 - Potassium metal partially replaces the hydrogen ion of sulphuric acid.
4. The table below gives examples of some salts. Give missing information in the table.

Name of salt	Formulae of salt	Source (acid)
Zinc nitrate	(a)	(b)
(c)	K_2SO_4	(d)
(e)	(f)	Hydrochloric acid
Ammonium sulphate	(g)	(h)

12.2 Physical properties of inorganic salts

Activity 12.2

Investigating Properties of inorganic salts

Apparatus and reagents

Magnesium sulphate, calcium sulphate, sodium carbonate, lead (II) nitrate, potassium nitrate, silver chloride, sodium chloride, lead (II) chloride, barium sulphate, test tube, weighing balance beaker, conductivity tester or ammeter

Procedure

1. Observe each of the salts given then provide the missing information in the table.

Salts	Formula	Physical state	Colour
Magnesium sulphate			
Calcium sulphate			
Sodium carbonate			
Lead (II) nitrate,			
Potassium nitrate.			
Silver chloride			
Sodium chloride			
Lead (II) chloride			
Barium sulphate			

2. Take 0.5 g of each of the salts provided in a test tube and add about 5cm³ of cold water. **Caution:** Do not warm. Close the test tube with your thumb and shake thoroughly. Put the test tube in a test tube rack. Observe then record your observations. If there is any solid left, add a little more water and shake again.

3. Repeat procedure 2 above but this time using hot water or warm the mixture using a Bunsen burner. Note what happens.

Record your results in the following table by ticking as appropriate.

Salts	Soluble		Insoluble	
	Cold water	Warm water	Cold water	Warm water
Magnesium sulphate				
Calcium sulphate				
Sodium carbonate				
Lead (II) nitrate				
Potassium nitrate				
Silver chloride				
Sodium chloride				
Lead (II) chloride				
Barium sulphate				

4. Write a report on the experiment findings. The report should have:

- Title of the experiment
- Aim of the experiment
- Requirements (materials, apparatus and reagents)
- Procedure
- Discussion and conclusion

5. Present your report to the class in the presence of your teacher.

I have discovered that...

Magnesium sulphate, calcium sulphate, sodium carbonate, lead (II) nitrate, potassium nitrate, silver chloride, sodium chloride and lead (II) chloride are white solids at room temperature.

Table 12.2: Examples of coloured salts

Salt	Colour
Hydrated copper (II) sulphate	Blue
Hydrated iron (II) sulphate	Green
Potassium permanganate	Purple
Potassium dichromate	Orange

From the experiment on solubility of salts in water, it is clear that there are salts, which are soluble, and those that are insoluble in water.

Table 12.2 Summary of solubility of salts

Soluble in cold water	Soluble in hot water	Insoluble
Sodium chloride Potassium nitrate Sodium carbonate Lead (II) nitrate Magnesium sulphate Potassium sulphate	Lead (II) chloride	Silver chloride Barium sulphate

The Facts

Among the soluble salts; some dissolve only if the solution is heated. This means that they dissolve only at slightly higher temperatures.

This category of salts dissolve much slower compared to those that dissolve in cold water i.e. they have lower solubility.

Salts that do not dissolve completely even after heating are said to be insoluble.

Solubility rules

1. All nitrates are soluble.
2. All sodium, potassium and ammonium salts are soluble.
3. All carbonate salts are insoluble except sodium carbonate, potassium carbonate and ammonium carbonate.
4. All sulphate salts are soluble except lead (II) sulphate, barium sulphate and calcium sulphate, which is sparingly soluble.
5. All chloride salts are soluble except lead (II) chloride and silver chloride.
However, lead (II) chloride is soluble in hot water.

Money matters!

When buying soap, I will consider its solubility to avoid using expensive soaps yet they take a lot of time to dissolve.

Activity 12.3

Experiment to demonstrate electrical conductivity of salts

1. Make solutions of various salts in experiment 12.2 in a small beaker.
2. Test the electrical conductivity of these solutions using the set up shown below.

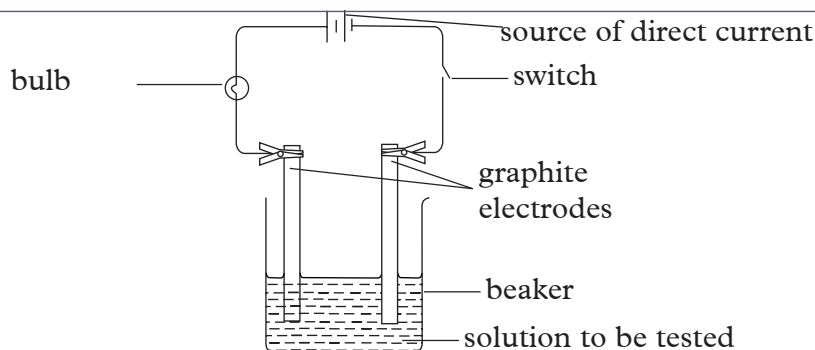

Fig. 12.2 Set-up to test electrical conductivity of solutions

- Switch on the current. Does the bulb light? What can you say about the solution? Rinse the beaker and graphite electrodes with distilled water then add the next solution. Test its conductivity and record your observations in a tabular form.

Table 12.3 Electrical conductivity of salts in aqueous form

Salts solution	Observation on the bulb
Magnesium sulphate	
Sodium carbonate	
Sodium hydrogen carbonate	
Lead (II) nitrate	
Potassium nitrate	
Sodium chloride	
Magnesium chloride	

I have discovered that...

All soluble salts i.e. those that dissolve in water to form solutions conduct electric current. That is why when the switch is closed, the bulb lights showing that the solution completes the circuit. Salt solutions in aqueous state ionise to form ions which carry electric charge within the solutions.

Self-evaluation Test 12.2

- Direct reaction between calcium carbonate and dilute sulphuric acid is not advisable in the preparation of calcium sulphate. Explain.
- (a) Comment on the solubility of calcium sulphate and lead(II)chloride.
(b) State an example of a salt which exists as:
 - White crystal
 - White powder
- The electrical conductivity of magnesium chloride was tested using the following set-up.

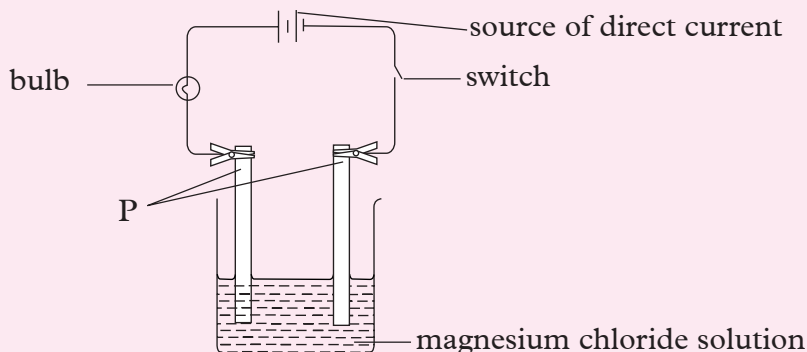

Fig. 12.3 Set-up to test electrical conductivity of magnesium chloride

- Name suitable materials for rods P.
- State the observation made when the switch was closed.
- What does this experiment tell you about the electrical conductivity of aqueous magnesium chloride?

12.3 Action of heat on salts

Activity 12.4

Experiment to investigate action of heat on carbonates and hydrogen carbonates

Apparatus and reagents

Test tubes, spatulas, match box, zinc carbonate, lead (II) carbonate, sodium carbonate, copper (II) carbonate, sodium hydrogen carbonate and calcium hydroxide solution.

Procedure

- Put into separate test tubes, about one spatula end-full of each of the carbonate or hydrogen carbonate provided.
- Heat each sample gently and observe what happens.
- Then heat strongly until no further change occurs.
- Using a delivery tube, connect the test tube containing the heated salt to another test tube containing lime water as shown in figure 12.4.

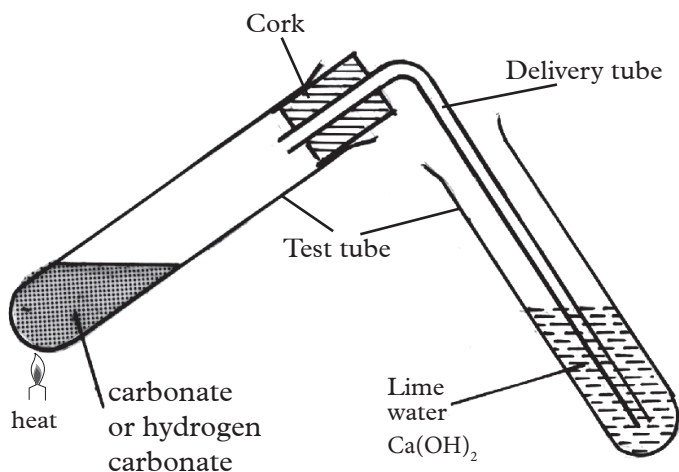

Fig. 12.4 Heating carbonates and hydrogen carbonates

5. Record your observations in the following table.

Table 12.4: Colour of some salts

Carbonate/ hydrogen carbonate	Colour before heating	Colour after heating	Effect of the gas on calcium hydroxide solution (lime water)
Zinc carbonate			
Lead (II) carbonate			
Sodium carbonate			
Copper (II) carbonate			
Sodium hydrogen carbonate			

Discussion corner!

1. Which carbonates are not affected by heat?
2. Which carbonates decompose when heated?
3. Write chemical equations for the reactions which occur in this experiment.

I have discovered that...

Sodium carbonate does not decompose when heated.

Zinc carbonate decomposes on heating to form a yellow solid that turns white on cooling and a colourless gas is given off. Lead (II) carbonate decomposes when heated to form a

red brown solid that turns yellow on cooling while a black solid is formed when copper(II) carbonate is heated. In all cases, a colourless gas is evolved.

The Facts

Group I compounds are very stable. They are not affected by heat. Such compounds include sodium carbonate and potassium carbonate.

Sodium hydrogen carbonate decomposes on heating to give sodium carbonate, carbon dioxide and water.



The carbon dioxide turns lime water milky. This is the test for carbon dioxide. Other metal carbonates apart from potassium and sodium carbonates decompose on heating to form metal oxides and carbon dioxide only i.e.



Zinc carbonate decomposes to give zinc oxide (yellow when hot and white when cold) and carbon dioxide. The carbon dioxide turns lime water milky.

Zinc carbonate $\xrightarrow{\text{heat}}$ zinc oxide + carbon dioxide



When white lead (II) carbonate is heated, it forms lead (II) oxide (red-brown when hot and yellow when cold) and carbon dioxide gas.



Green copper (II) carbonate forms black copper (II) oxide and carbon dioxide gas when heated.



In general, carbonates decompose on heating to give corresponding metal oxide and carbon dioxide gas. The gas reacts with calcium hydroxide solution to form calcium carbonate hence the solution turns milky. This is the test for carbon dioxide gas i.e.

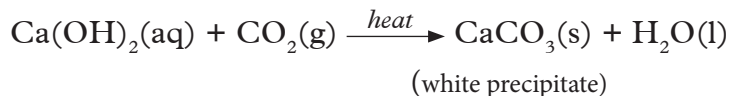

Activity 12.5

Experiment to determine action of heat on sulphates

Apparatus and reagents

Hydrated copper (II) sulphate, hydrated iron (II) sulphate, test tubes, Bunsen burner,

Procedure

1. Put one spatulaful of hydrated copper (II) sulphate crystals and anhydrous copper (II) sulphate crystals in separate test tubes.

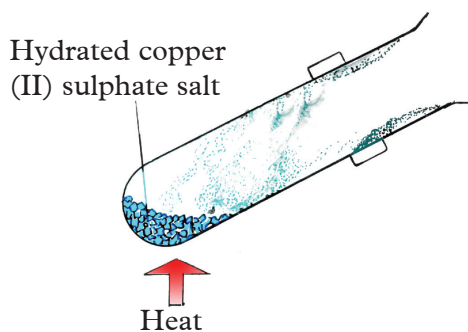

Fig. 12.5: Heating sulphate

- Heat each test tube gently and then strongly. Record your observations.
- Repeat procedures 1 and 2 above but this time using hydrated iron (II) sulphate. Record your observations.

Discussion corner!

- State the observations made when each of the hydrated salts is heated gently.
- State the observations made when each of the sulphate salt is heated strongly.
- Write equations for the reactions that take place.

I have discovered that...

When hydrated copper (II) sulphate crystals are gently heated, the blue crystals gradually turn into a white solid and droplets of a colourless liquid collect on the cooler parts of the test-tube. On further heating however, the white solid changes to a black solid. When a wet blue litmus paper is placed at the mouth of the test-tube, it turns red. When hydrated iron (II) sulphate is gently heated, a white powder is formed and droplets of a colourless liquid collect on the cooler parts of the test tube. On further heating the powder changes to a brown powder. A wet blue litmus paper placed at the mouth of the test-tube turns red.

The Facts

Hydrated copper (II) sulphate contains water of crystallization. When gently heated it loses the water of crystallisation to form anhydrous copper (II) sulphate which is a white solid.

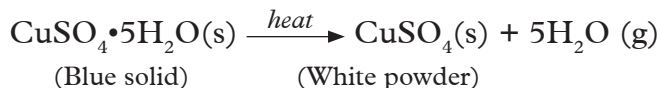

Anhydrous copper (II) Sulphate when strongly heated decomposes further to give a black solid that is, copper (II) oxide and sulphur dioxide gas. This gas is acidic.

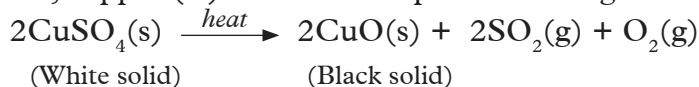

Green hydrated iron (II) sulphate crystals when heated forms iron (II) sulphate and gives out water.

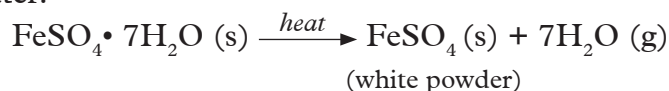

When anhydrous iron (II) sulphate is heated more strongly a red- brown iron (III) oxide solid is formed together with a mixture of sulphur trioxide and sulphur dioxide gases. These gases are acidic and turn moist blue litmus paper red.

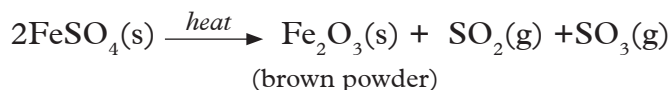

Hydrated sulphates give out their water of crystallisation when heated. Sulphates of potassium, sodium, calcium and magnesium are stable and are not decomposed by heat.

Money matters!

Due to the huge expenses incurred in buying laboratory chemicals, ensure that you always keep the reagents properly and with their tops tightly closed to prevent contamination.

Activity 12.6

Experiment to determine action of heat on nitrates

Apparatus and reagents

Potassium nitrate, sodium nitrate, copper (II) nitrate, lead (II) nitrate, silver nitrate, test tubes, Bunsen burner, moist litmus paper, splints.

Procedure

1. Heat half a spatula of each of the nitrates provided in separate test tubes.
2. Test for any gases evolved using both moist blue and red litmus paper and a glowing splint.

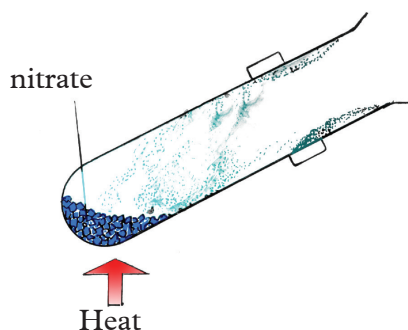

Fig. 12.6 Heating nitrates

Caution: Avoid inhaling the gas that may be evolved.

3. Record your results in the following table.

Table 12.4: Action of heat on nitrates

Nitrate	Colour before heating	Colour after heating	Effect of the gas on moist litmus paper
Potassium nitrate			
Sodium nitrate			
Copper (II) nitrate			
Lead (II) nitrate			
Silver nitrate			

Discussion corner!

1. Write equations for the reactions that occur.
2. Classify the nitrates according to the effect of heat on each one of them.

The Facts

Sodium nitrate and potassium nitrate decompose on heating to give the corresponding metal nitrites and oxygen gas.

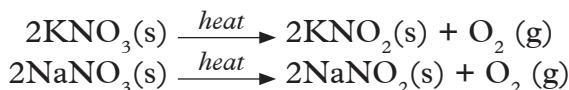

Copper (II) nitrate decomposes on heating to give copper (II) oxide, brown fumes of nitrogen dioxide and oxygen gas. Nitrogen dioxide turns blue litmus paper red while the oxygen relights a glowing splint.



When heated white lead (II) nitrate produces a cracking sound and forms lead (II) oxide, which is reddish brown solid when hot and yellow when cold. A red dish brown gas i.e. nitrogen dioxide is evolved. Oxygen is also produced. Oxygen relights a glowing splint.



On strong heating, silver nitrate gives silver metal, nitrogen dioxide and oxygen gas.

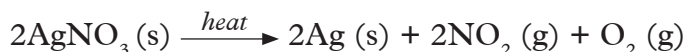

Similarly, nitrates of other metals low in the reactivity series decompose to yield the corresponding metal, nitrogen dioxide and oxygen gas.



Therefore, nitrates of metals high in the reactivity series decompose on heating to give corresponding nitrites and oxygen. Nitrates of moderately reactive metals give corresponding metal oxides, nitrogen dioxide and oxygen on heating while least reactive metals give corresponding metal, nitrogen dioxide and oxygen gas.

What do you think would be the products of heating aluminium nitrate and zinc nitrate?

Ammonium nitrate, unlike other nitrates, decomposes to give dinitrogen monoxide (nitrous oxide) and water.



Self-evaluation Test 12.4

- Name two metal carbonates, which do not decompose when heated.
 - Name the products formed when the following carbonates are heated.
 - Zinc carbonate
 - Lead (II) carbonate
 - Write equations to show the action of heat on the carbonates in (b).
 - Write a chemical equation to represent the action of heat on sodium hydrogen carbonate.
- State and explain the observation made when hydrated copper (II) sulphate crystals are heated gently then strongly.
 - State and explain the observations made when anhydrous iron(II)sulphate is heated gently then strongly.
 - Write equations for the reactions that occur in 2(a) and (b) above.
- Predict the products that would be formed if the following nitrates are heated.
 - Calcium nitrate
 - Magnesium nitrate
 - Write equations for the reactions in 3(a) above.

Remember the facts...

- A salt is a compound obtained when all, or part of the replaceable hydrogen atoms of an acid are replaced by a metal ion or ammonium ion.
- The names of various classes of salts are derived from the acids from which they are prepared. Normal salts do not have any replaceable hydrogen ions. Acid salts have at least one replaceable hydrogen ion remaining in its structure.
- Some of the physical properties of salts include different colours and physical states at room temperature, solubility in water and electrical conductivity.
- Salts soluble in water form solutions, which are good electrical conductors. Insoluble salts do not conduct electric current.

- Heat does not decompose carbonates of potassium and sodium. Most carbonates however, decompose on heating to give metal oxides and carbon dioxide.
- Sodium hydrogen carbonate decomposes on heating to give sodium carbonate, carbon dioxide and water.
- Hydrated copper (II) sulphate and hydrated iron (II) sulphate give out water of crystallisation when heated before the anhydrous salts proceed with decomposition.
- Nitrates of metals high in the reactivity series decompose on heating to give corresponding nitrites and oxygen. Nitrates of moderately reactive metals give corresponding metal oxides, nitrogen dioxide and oxygen on heating. Least reactive metal nitrates give corresponding metal, nitrogen dioxide and oxygen gas.

Test Your Competence 12

- (a) What do you understand by the term salt?
(b) A certain salt is made when ammonium ion displaces all the hydrogen ions of sulphuric acid. Give the name and formula of the salt formed.
- (i) State the observations made when hydrated copper (II) sulphate crystals are heated gently then strongly .
(ii) Write the chemical equations for the changes that take place in 2 (i).
- The following flow diagram shows what happens when a certain carbonate of metal X is heated strongly.

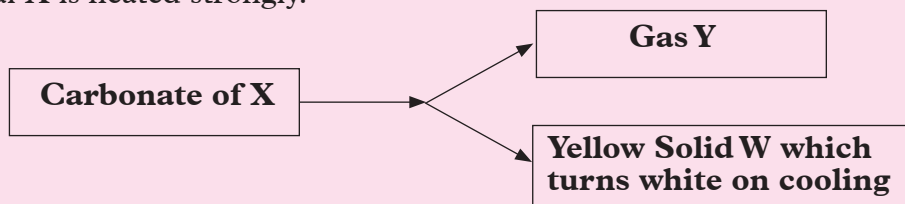

- Identify:
 - Gas Y
 - Yellow Solid W
 - What is the colour of the carbonate of X?
 - What is metal X?
- (a) State the products formed when sodium hydrogen carbonate is heated.
(b) Write a chemical equation for the reaction in 4(a) above.
 - Give the general name given to the salts derived from the following acids.
 - Nitric acid
 - Carbonic acid
 - Sulphuric acid
 - (a) State the colour of sodium chloride salt.
(b) Carry out an investigation to determine electric conductivity of a solution of sodium chloride as shown below.

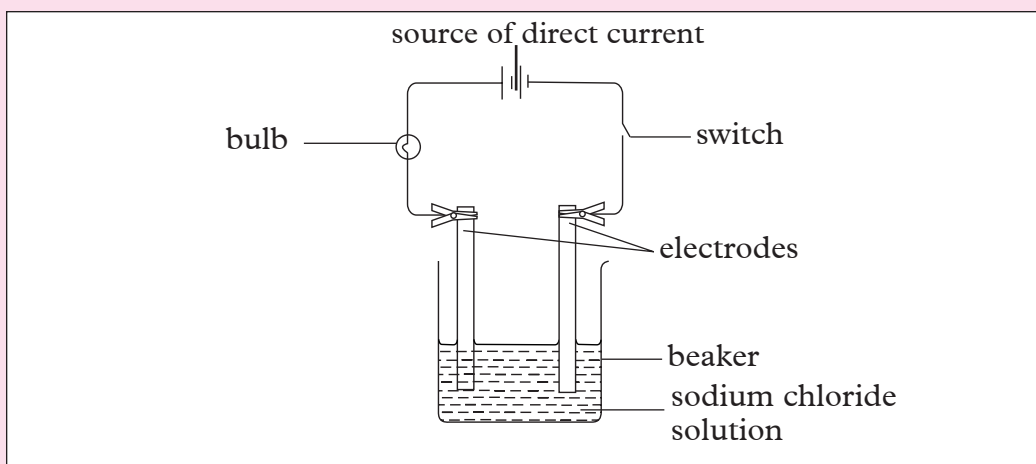

- (i) State the observations made when the switch was closed.
(ii) Name a suitable material for the electrodes.
(iii) What do you conclude about the electrical conductivity of aqueous sodium chloride?

7. Classify the following salts as either normal salt or acid salt.

- (a) FeSO_4 (c) ZnBr_2
(b) NaHCO_3 (d) PbI_2

8. Classify the following salts as either soluble or insoluble.

AgNO_3	$\text{Zn}(\text{NO}_3)_2$	CaCO_3	MgSO_4	NaHSO_4	PbCl_2	BaSO_4	AgCl
-----------------	----------------------------	-----------------	-----------------	------------------	-----------------	-----------------	---------------

Living things require oxygen in order to stay alive. Look at the figure below. What is going on in the figure? Talk to your friend about it.

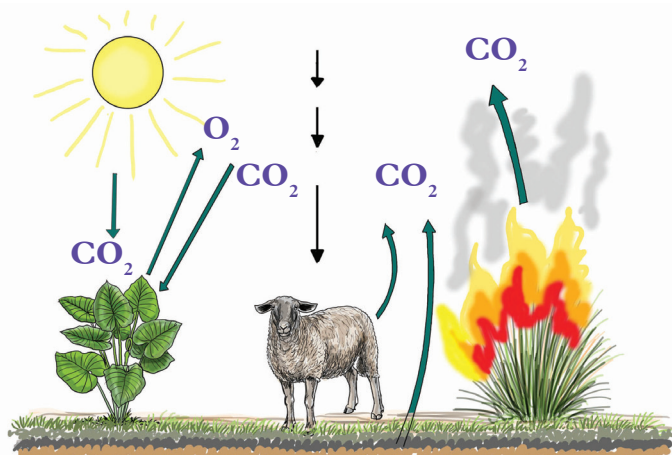

Fig. 13.1 Gaseous exchange in organisms

Give the importance of oxygen and carbon dioxide to living things from your discussion.

Key unit competency

After studying this unit, I should be able to:

- Prepare oxygen in the laboratory.
- Show how oxygen supports burning.
- Show the reaction of oxygen with some elements.
- Prepare other gases to demonstrate different methods of gas collection.

Unit outline

13.1 Methods of preparation of oxygen gas

13.2 Physical properties of oxygen

13.3 Chemical properties of oxygen

13.4 Methods of collecting gases

13.5 Uses of oxygen

13.6 Ozone

Introduction

Oxygen forms about 20% of air. The remaining percentage is occupied by nitrogen, carbon dioxide and inert gases. Green plants produce oxygen during photosynthesis thereby making it available for animals. Plants and animals use oxygen for respiration. Animals on the other hand give out carbon dioxide which plants use during photosynthesis to make food.

Away from the earth in the stratosphere, there is the ozone layer, (O_3). Ozone is one of the allotropes of oxygen. It protects living organisms from harmful radiations from the sun. Human activities that cause air pollution lead to depletion of ozone layer. When this happens, the harmful radiations reach the earth's surface and can cause skin cancer or damage to crops. It is therefore important that we keep the atmosphere clean. Think of some of the practices we can adopt to safeguard our atmosphere.

13.1 Methods of preparation of oxygen gas

Activity 13.1

Experiment to prepare oxygen from hydrogen peroxide

Apparatus and reagents

Weighing balance, trough, water, stopper, delivery tube, flat-bottomed flask, dropping funnel, matchbox, splints, blue and red litmus papers, gas jar, hydrogen peroxide and manganese dioxide.

Procedure

1. Weigh 5g of manganese dioxide using the weighing balance and put in the flat-bottomed flask.
2. Set up the apparatus as shown in Fig.13.2 below.
3. Add hydrogen peroxide from the dropping funnel to the manganese dioxide in the flat-bottomed flask. Observe and note what happens.
4. Test the gas collected using a glowing splint and the litmus papers.

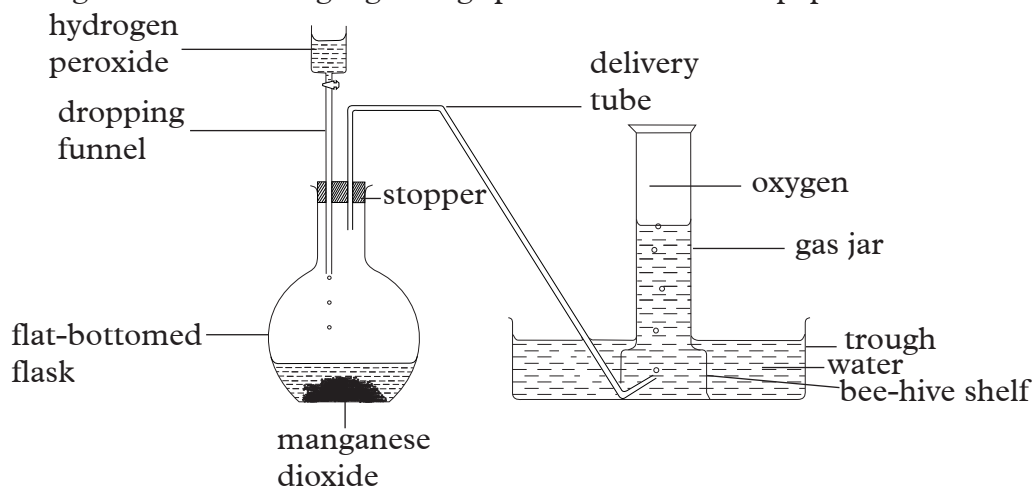

Fig 13.2: Set-up to prepare and collect oxygen gas in the laboratory

Discussion corner!

1. What properties of the gas did you consider when collecting the gas?
2. What is the colour of the gas collected?
3. What happened to the (a) glowing splint? (b) red litmus paper? (c) Blue litmus paper?
4. What can you conclude about the nature of oxygen gas?

I have discovered that...

When we are collecting a gas, we consider its physical properties such as density and solubility in water. Oxygen is a colourless odourless gas. It is also a neutral gas.

The facts

Hydrogen peroxide decomposes to produce oxygen. The decomposition of the peroxide is speeded up by manganese dioxide, which acts as a **catalyst**.

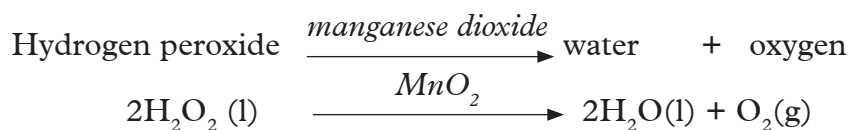

The oxides of heavy metals with high oxidation state, such as lead can also be used to prepare oxygen in the laboratory.

My environment my life!

Lead is poisonous when it comes in contact with biological systems. Hence ensure proper disposal of the products of preparation of oxygen when using lead dioxide.

The oxygen gas produced has no effect on moist red or blue litmus paper. It is a neutral gas.

The gas relights a glowing splint. This is the confirmatory test for oxygen gas.

Activity 13.2

Laboratory preparation of oxygen using sodium peroxide.

Apparatus and reagents

Sodium peroxide, water, gas jar, thistle funnel, trough, bee-hive shelf, delivery tube, flat-bottomed flask.

Procedure

1. Put a small amount of powdered sodium peroxide into the flat-bottomed flask.
2. Arrange the apparatus as shown in figure 13.3 below.

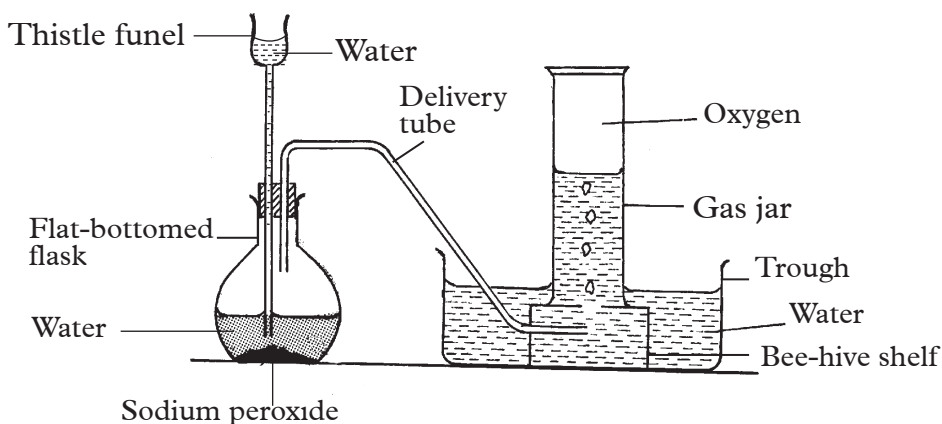

Fig 13.3: Set-up to prepare and collect oxygen in the laboratory

- Drop water through the thistle funnel to the sodium peroxide. What do you observe?
- Collect the gas produced and perform the tests in activity 13.1. Is the gas oxygen?

I have discovered that...

When water is added to sodium peroxide, bubbles of a gas are produced. The gas is colourless and has no smell.

The Facts

Sodium peroxide reacts with water to form sodium hydroxide and oxygen gas.

Sodium peroxide + water \longrightarrow Sodium hydroxide + oxygen.



Activity 13.3

Experiment to prepare oxygen from potassium chlorate

Apparatus and reagents

Boiling tube, delivery tube, test tube, trough, distilled water, splints, wet red and blue litmus papers, potassium chlorate, manganese dioxide, Bunsen burner.

Procedure

- Place a mixture of 4 g of potassium chlorate and 1g of manganese dioxide in a boiling tube.
- Set up your apparatus as shown in Fig 14.4 below.

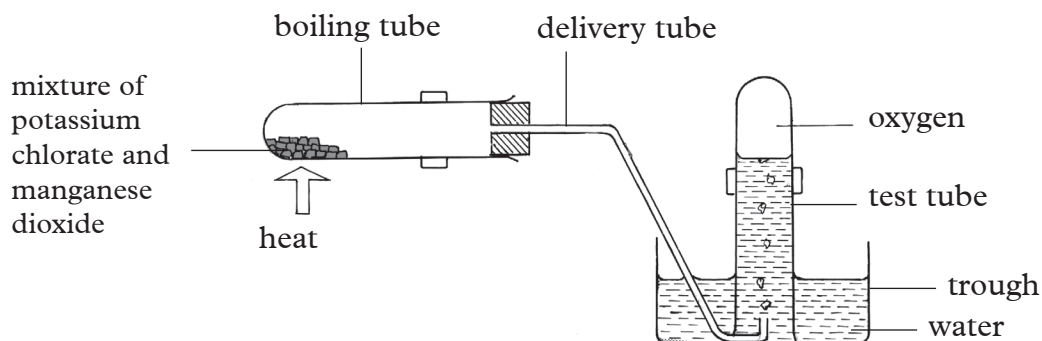

Fig 13.4: Preparation of oxygen using potassium chlorate

- Heat the mixture gently then strongly.
- Test the gas collected using a glowing splint and wet red and blue litmus papers. Write your observations.

I have discovered that...

On heating a mixture of potassium chlorate and manganese dioxide, the mixture decomposes into a white solid and a colourless gas. The gas relights a glowing splint and has no effect on moist blue or red litmus papers.

The Facts

The white solid formed after heating is potassium chloride and the gas is oxygen. Manganese dioxide acts as a catalyst for the reaction.

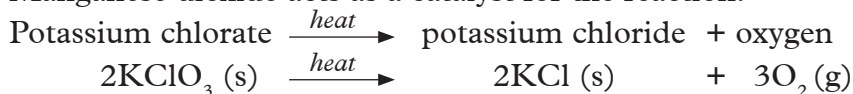

The oxygen produced in all these cases relights a glowing splint. This is the confirmatory test for oxygen. The gas is collected over water since it is slightly soluble in water.

Another method that can be used to prepare oxygen in the laboratory is heating nitrates of group I metals, for example sodium nitrate and potassium nitrate.

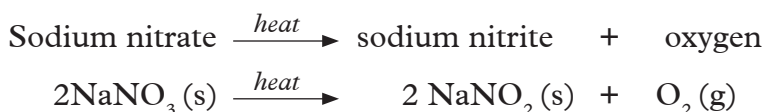

Self-evaluation Test 13.1

- (a) Given water and sodium peroxide describe how oxygen can be prepared in the laboratory.
(b) Illustrate the method identified in 1 (a) using a diagram.
- (a) Although oxygen is important for respiration, it is poisonous to some organisms. Explain.
(b) Discuss why preparation of oxygen using lead compounds is discouraged.
- Sodium nitrate can be used to prepare oxygen in the laboratory. Write a chemical equation to illustrate its decomposition on heating.

13.2 Physical properties of oxygen

Activity 13.4

Experiment to investigate physical properties of oxygen

Apparatus and reagents

Two test tubes full of oxygen, litmus papers, trough and distilled water.

Procedure

- Investigate the smell of oxygen.
Caution! Always smell a gas by wafting it towards your nose.
- Drop moist blue and red litmus papers in one test tube full of oxygen.
- Insert the second test-tube full of oxygen in a trough with distilled water and note the level of water inside the gas jar. Leave the set up for 20 minutes and note any change in the water level.

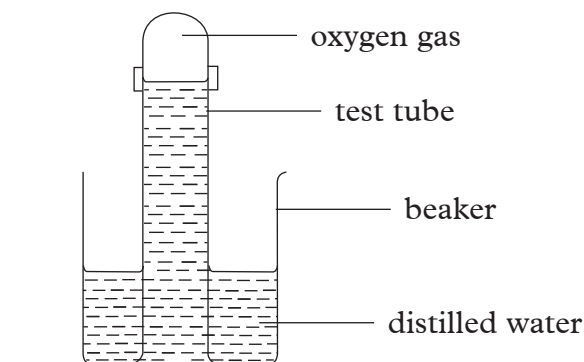

Fig 13.5: Dissolving oxygen in water

1. What is the smell of oxygen?
2. What is the effect of oxygen on the moist litmus papers?
3. What changes do you observe in the test tube inverted in water? Explain your observation.
4. From the results of the experiment, state physical properties of oxygen.

I have discovered that...

Oxygen is a colourless odourless gas. It has no effect on moist litmus papers. When a test tube full of oxygen is inverted in water, the level of water rises slightly in the tube.

The Facts

Some of the physical properties of oxygen include:

1. It is slightly denser than air.
2. Oxygen is slightly soluble in water.
3. It is a neutral gas.

Self evaluation test 13.2

1. Research on the melting and boiling points of oxygen.
 - (a) Are the temperatures low or high?
 - (b) Discuss why oxygen has such melting and boiling points.
2. Describe how you would use litmus to differentiate between oxygen and sulphur dioxide gas.

13.3 Chemical properties of oxygen

Activity 13.5

Experiment to demonstrate that part of air is used in burning

Apparatus and reagents

Candle, trough, water, cork, matchbox, gas jar

Procedure

1. Put some water in a trough as shown below.
2. Put a short candle on a cork and float the cork with the candle on the water as shown in figure 13.6.

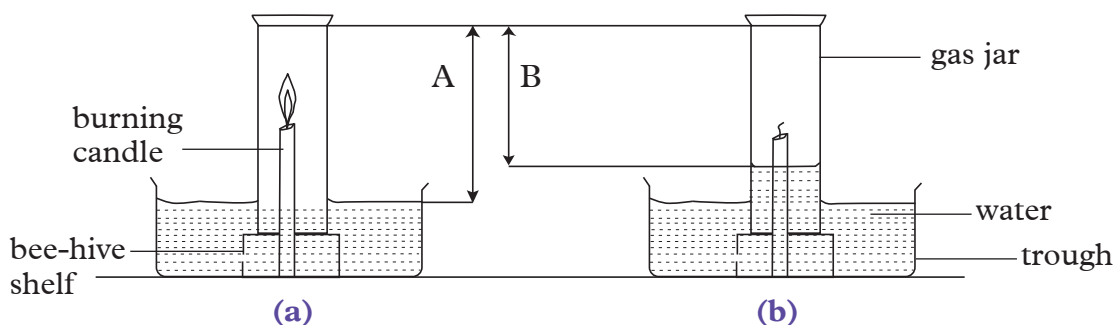

Fig 13.6: Experimental set-up

3. Cover the candle with a gas jar and mark on the gas jar the level of the water. Measure the height of the air column (A) and record it.
4. Now remove the gas jar and light the candle. Gently cover it with the gas jar again and observe what happens.
5. Mark the final level of water inside the gas jar when there is no further change. Measure and record the height of the air column (B) once more.

Discussion corner!

1. State and explain what happens to the candle after some time.
2. State and explain what happened to the level of water at the end of the experiment.
3. What was the length of the air column in the gas jar before and after burning?
4. Using the results of this experiment, calculate the percentage of air used up in burning.
5. Is it necessary to leave the apparatus to cool before making the final reading? Explain.
6. State any sources of errors in this experiment.

I have discovered that...

After burning for a while, in a fixed volume of air, the candle goes off and the level of the water in the gas jar rises. The candle goes off because the part of air used in burning is exhausted. The part of air used in burning is called “**active part of air**” and therefore what remains in the gas jar is the “inactive part of air”. Since part of the air is used up in burning, a partial vacuum is created in the gas jar. Greater atmospheric pressure acting on the surface of the water forces the level of water in the gas jar to go up.

The Facts

The active part of air used in burning is oxygen. Oxygen forms about 21% by volume of air. The part of air that remains in the gas jar does not support combustion and it is mainly nitrogen. Dilute sodium hydroxide can be used in place of water in this experiment. Its advantage over water is that it can absorb carbon dioxide initially in the gas jar and that which is produced during burning. Heating causes expansion of gases therefore the apparatus should cool first before final length of the air column is taken.

Activity 13.6

Experiment to demonstrate reaction of oxygen with metals

Apparatus and reagents

Gas jars full of oxygen, deflagrating spoon, tongs, litmus papers, Bunsen burner, magnesium, iron, copper, calcium, distilled water.

Procedure

1. Place a piece of calcium in a deflagrating spoon. Heat to burn then lower the burning metal into a gas jar of oxygen. What do you observe?
2. Lower a piece of burning magnesium ribbon by the use of tongs into a jar of oxygen. How does it burn? What is the colour of the product formed?
3. Add some water to the product formed, shake and test the solution formed with litmus paper. Repeat this for all other metals in this experiment. What do you observe?

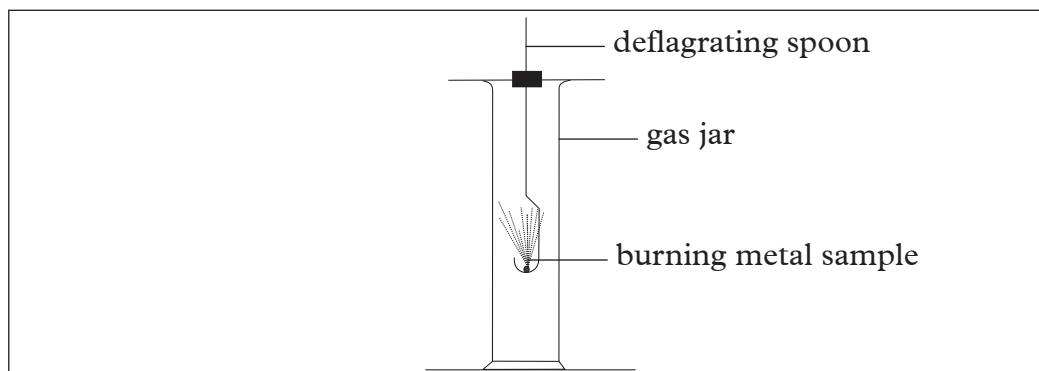

Fig 13.7: Reaction of metals with oxygen

4. Attach a small piece of iron wire at the end of a deflagrating spoon, heat until the wire glows red. Lower the glowing wire into a gas jar of oxygen. Record any observations. Repeat the experiment using a piece of copper instead of iron wire. Record your observations.

Discussion corner!

1. Why do you think red litmus paper turns to blue while the blue one retains its colour in procedure 3?
2. Write symbolic equations for the reactions.
3. What is the general name given to the products formed when metals burn in oxygen?
4. What is the name given to the reaction of oxygen and elements?

I have discovered that...

*When elements burn in oxygen, they form oxides. Thus an oxide is a binary compound of oxygen and another element. The reaction of oxygen and elements to form oxides of the elements is called **oxidation**. Most metals burn in oxygen to form basic oxides. Some basic oxides dissolve in water to form alkaline solutions*

The Facts

- (i) Magnesium burns brightly in oxygen to form a white powder; magnesium oxide.



The magnesium oxide dissolves in water to form magnesium hydroxide, which turns red litmus paper to blue. It is hence considered to be basic.



- (ii) Calcium burns vigorously with a bright red flame in oxygen to form a white solid, calcium oxide.

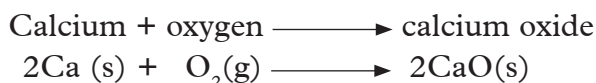

The calcium oxide dissolves slightly in water to form calcium hydroxide solution. Calcium hydroxide turns red litmus paper to blue.



(iii) When a red-hot iron wire is lowered in a gas jar of oxygen, it burns with yellow sparks to form insoluble oxide; iron trioxide.

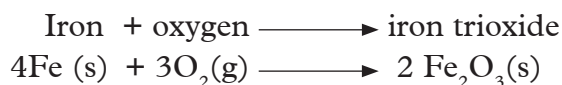

Since the oxide is insoluble in water, it has no effect on litmus paper.

(iv) Copper burns in oxygen with a blue-green flame forming copper (II) oxide, which is black.

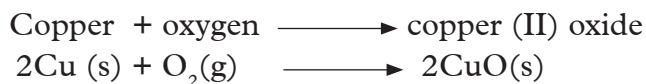

Copper (II) oxide is insoluble in water. It has no effect on litmus paper.

Activity 13.7

Experiment to demonstrate reaction of oxygen with non-metal elements

Apparatus and reagents

Gas jars full of oxygen, litmus papers, distilled water, deflagrating spoon, sulphur powder, charcoal, phosphorous.

Procedure

1. Place 1 g of sulphur powder in a deflagrating spoon and heat it until it starts to burn. Lower the burning sulphur in a gas jar of oxygen and record your observations.

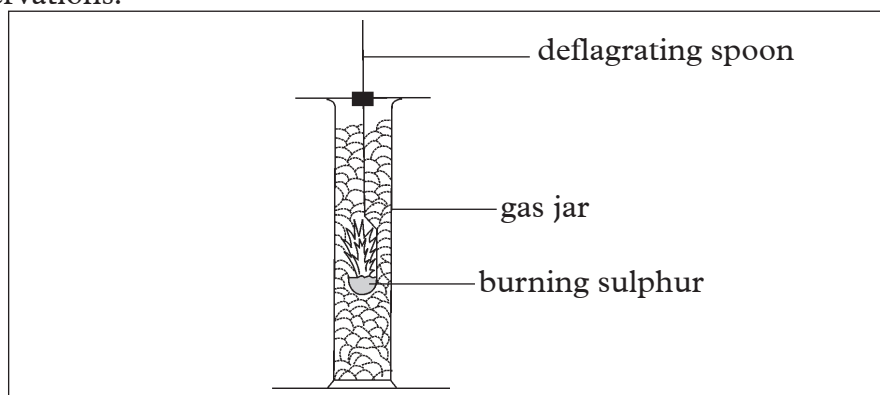

Fig 13.8: Reaction of non-metals with oxygen

2. Place moist litmus papers in the gas jar. What do you observe?
3. Place a small lump of charcoal in a deflagrating spoon and ignite it with fire until it is red-hot.
4. Place the red-hot charcoal in a gas jar of oxygen. What do you observe?
5. Place moist litmus papers in the gas jar. What observation do you make?

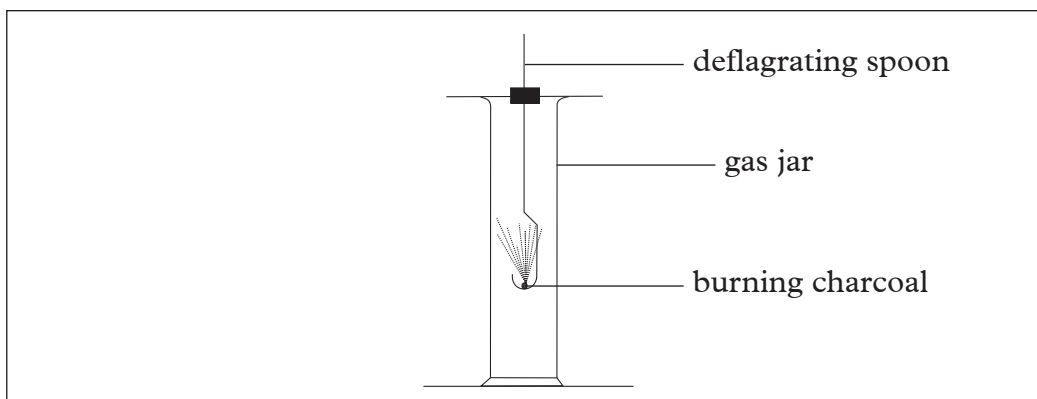

Fig. 13.9 Reaction of charcoal with oxygen

1. What is the colour of the product that is formed when sulphur is burned in oxygen?
2. Write word equations for the reactions that occur in activity 13.7 and 13.8.
3. How does moist litmus papers change when placed in the gas jars during the combustion?

I have discovered that...

Sulphur burns in oxygen with a pale blue flame. It burns to form a colourless gas with a choking smell. Some white fumes are also formed. Sulphur dioxide turns moist blue litmus paper red. It is an acidic gas.

My environment, my life!

I will champion for recycling of materials made of sulphur to conserve the environment.

When non-metals are oxidised, they form acidic oxides. Acidic oxides cause air pollution when released into the atmosphere.

Sulphur burns in oxygen to form sulphur dioxide.



Sulphur dioxide dissolves in water to form sulphurous acid.

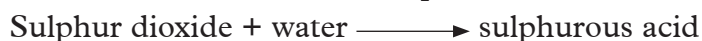

Self-evaluation Test 13.3

1. (a) State three physical properties of oxygen.
(b) What is oxidation?
2. Complete the following table to show how the metals react when burnt in oxygen.

Metal	How it burns in oxygen	Appearance of product	Name of the oxide	Solubility of the oxide in water	Effect of the oxide solution on litmus
Calcium			Calcium oxide		
Copper					No effect on litmus
Sodium				Soluble	
Magnesium		White solid			
Iron	Glows red-hot with sparks				

3. (a) The table below is an incomplete record of observations made when non-metals are burnt in oxygen. Complete the table by filling in the blank spaces.

Non-metal	How it burns in oxygen	Name of the oxide formed	Appearance of the oxide	Effects of the oxide solution on litmus paper
Phosphorous	Burns with a bright flame			
Carbon		Carbon dioxide		
Sulphur			White fumes	Turns red

(b) Write symbolic chemical equations for the reactions that take place when the three non-metals are burnt in oxygen.

4. Why do you think we should economise on the use of reagents when performing experiments?

13.4 Methods of collecting gases

During your chemistry course, you will prepare a number of gases. Generally, after a gas has been prepared, it is directed to the collecting system via a delivery tube or it may first pass through a purification system.

Health check!

It is important to use the fume chamber to prepare poisonous gases because we consider the safety of other laboratory users a priority!

The Facts

Collection of gases in the laboratory depends on the physical properties of the gas. Such properties include:

- Solubility in water
- Density of the gas

Gases can be collected using the following methods:

- Over water
- Downward delivery
- Upward delivery

1. Collection of gases over water

This method is appropriate for gases that are insoluble or slightly soluble in water and those that do not react with water. The gas jar must be filled with water first and the beehive shelf placed under water in the trough as shown in fig 13.10.

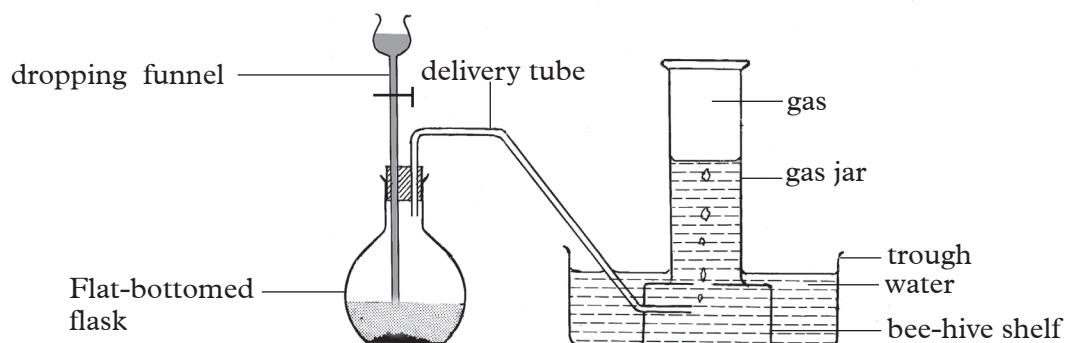

Fig 13.10 Collection of a gas over water

This method can be used to collect gases such as oxygen, nitrogen, dinitrogen oxide, nitrogen monoxide, carbon monoxide and hydrogen sulphide.

The advantage of this method of gas collection is that you can always see when the gas jar is full.

If the gas is required dry, it is passed through concentrated sulphuric acid or anhydrous calcium chloride.

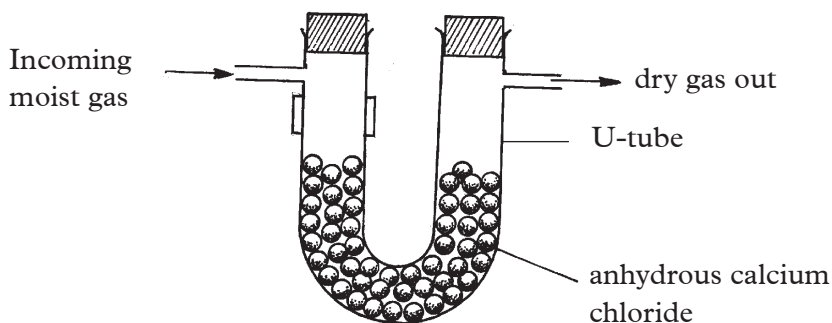

Fig 13.11 Drying of a gas using anhydrous calcium chloride

Gases, such as ammonia, sulphur dioxide and hydrogen chloride are highly soluble in water. Therefore, they should never be collected over water.

The following examples illustrate preparation and collection of gases over water.

(a) Preparation and collection of nitrogen gas.

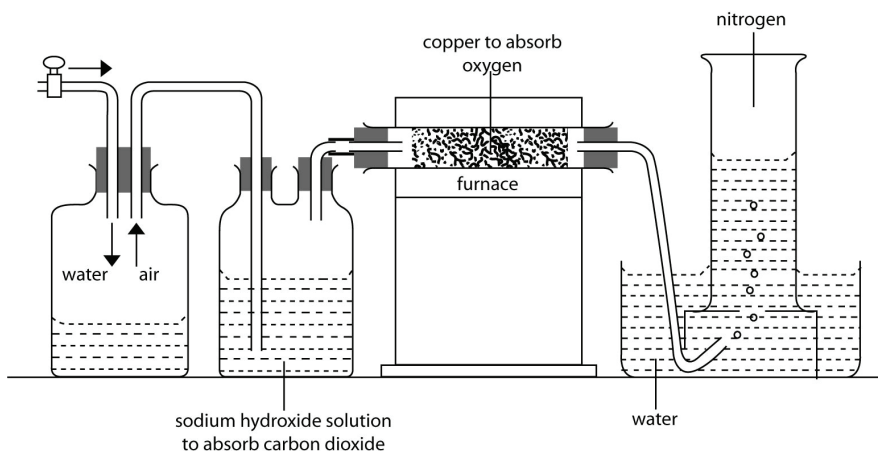

Fig 13.12: Set-up to prepare and collect dry nitrogen gas in the laboratory

(b) Preparation and collection of oxygen.

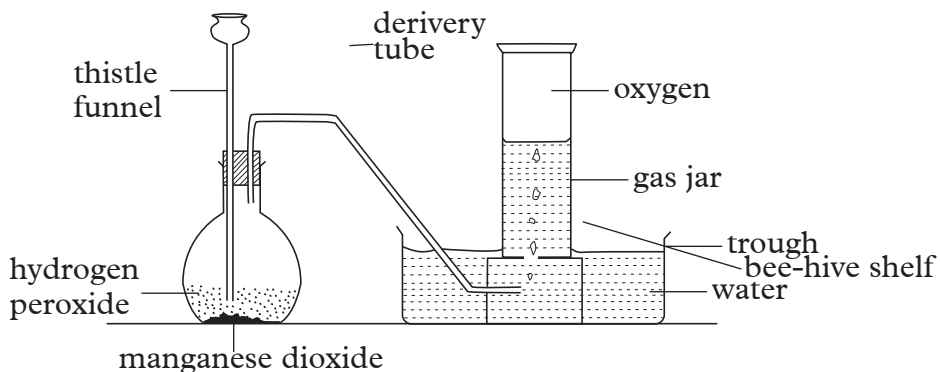

Fig 13.13: Set-up to prepare and collect dry oxygen gas in the laboratory

2. Collection of gases by downward delivery

This method is used for collection of gases that are denser than air. It is also called upward displacement of air as illustrated in fig 13.14. The set-up to be used is as shown below.

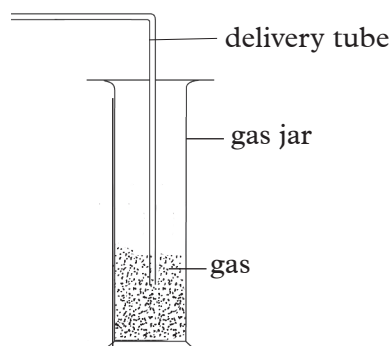

Fig 13.14 Collection of a gas by downward delivery

The main disadvantage of this method is that gases diffuse so fast that the gas collected will almost certainly contain some air. Also, unless the gas is coloured, it may not be easy to know when the gas jar is full.

Gases that can be collected by this method include carbon dioxide, sulphur dioxide, chlorine, nitrogen dioxide and hydrogen sulphide.

The following examples illustrate collection of gases by downward delivery.

(a) Preparation and collection of chlorine.

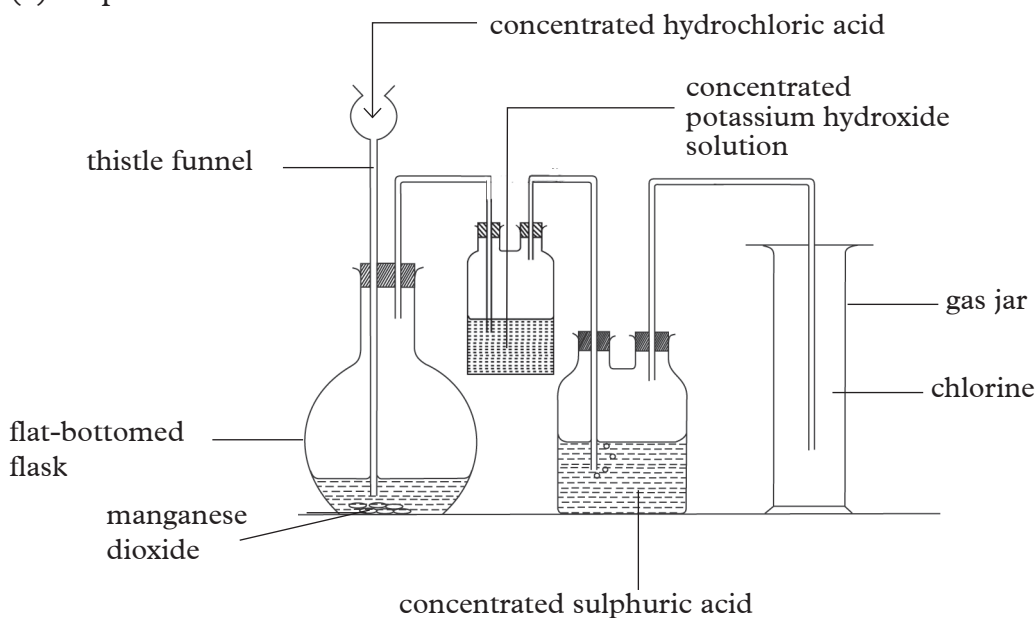

Fig 13.15 Set-up to prepare and collect dry chlorine gas

(b) Preparation and collection of dry carbon dioxide.

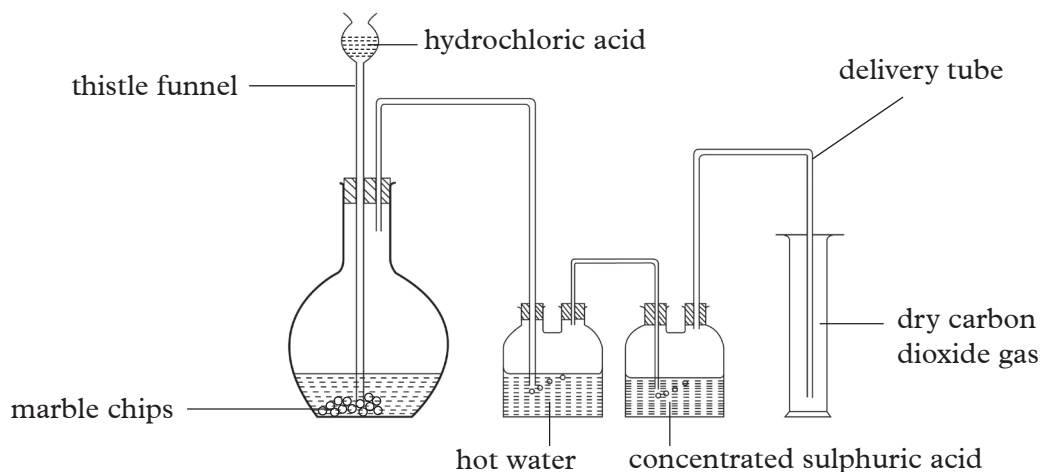

Fig 13.16 Set-up to prepare and collect dry carbon dioxide gas

3. Collection of gases by upward delivery

This method is used for collecting gases that are less dense than air. This method is also called downward displacement of air as illustrated in fig 13.17

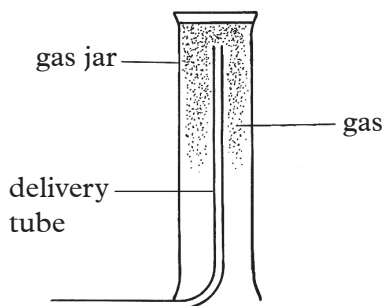

Fig 13.17 Set-up for collecting gases by upward delivery method

The disadvantage of this method is that you may not easily know when the gas jar is full. Also because of diffusion of gases, it may be contaminated with air.

Gases that can be collected by this method are hydrogen and ammonia.

The following example illustrates collection of gases by upward delivery.

(a) Preparation and collecting of ammonia

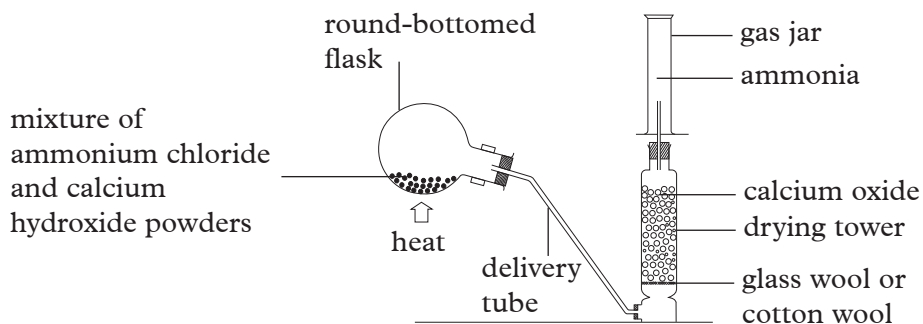

Fig 13.18 Set-up to prepare and collect dry ammonia gas

Money matters

It is important to ensure that we choose the appropriate method of collecting a gas during preparation. This will ensure that we do not misuse expensive laboratory chemicals.

Self-evaluation Test 13.4

1. State the physical properties considered when collecting a gas.
2. Identify the method that can be used to collect the following gases:
 - (a) Oxygen
 - (b) Carbon dioxide
 - (c) Ammonia
3. Draw well-labelled diagrams to illustrate the following methods of gas collection.
 - (a) Upward delivery
 - (b) Downward delivery

13.5 Uses of oxygen gas

1. Oxygen is necessary for **respiration**. When we eat food, it is oxidised to produce energy for various body activities. Such activities include movement, growth, reproduction and circulation of blood.
Food + oxygen \longrightarrow energy + carbon dioxide + water vapour
Thus plants and animals oxidise food to get energy.

My environment, my life!

Always plant trees each time you cut one and also plant where none existed before. Trees increase concentration of oxygen in the atmosphere.

2. Industrially manufactured oxygen is used as a respiratory aid in places where natural supply of oxygen is insufficient. For example in:
 - (a) Hospitals by patients with breathing difficulties and also when an anaesthetic is being administered to patients.
 - (b) Deep sea diving.
 - (c) High altitude flying and mountain climbing.
3. Oxygen is used in oxy-acetylene or oxy-hydrogen flame for welding and cutting of metals. This flame has very high temperature which enables it to melt and cut metals.
4. Liquid oxygen is used in burning of fuels to propel rockets.
5. Oxygen is used in to remove impurities during steel making. A blast of oxygen is blown through molten, crude iron. It combines with the impurities in iron,

for example carbon and sulphur. The products are gases which disappear in the air.

6. Liquid oxygen mixed with charcoal and petrol is used as an explosive in mines.

Self-evaluation Test 13.5

1. Discuss uses of oxygen in:
(a) Hospitals (b) Welding (c) Respiration
2. Why do you think it is necessary to plant a tree each time you cut one and also plant more?
3. "Without oxygen there will be no life on earth" Discuss.

13.6 Ozone

The existence of an element in two or more forms in the same physical state is known as **allotropy**. Different forms of an element existing in the same physical state are known as **allotropes**. Ozone is a trioxygen molecule in the upper atmosphere (stratosphere). Ozone is produced by reactions involving oxygen and ultra-violet radiations.

It acts as a blanket, which protects life on earth from harmful ultra violet radiations. Some radiations if allowed to reach the lower atmosphere, can cause:

1. Sunburn and certain forms of skin cancer to human beings.
2. Damage to crops.
3. Direct DNA damage to some living organisms.

Research has shown that the ozone layer is depleted due to the use of chlorofluorocarbons (CFCs), which are used as propellants in insecticides and aerosol sprays-cans. Chlorofluorocarbons are also used as refrigerant liquids. When CFCs reach the upper atmosphere, they undergo photochemical reactions with ozone, converting it to oxygen.



Depletion of ozone reduces its properties and as a result, harmful ultra violet radiations penetrate easily posing health risks to organisms on earth.

Quality check!

We should only buy and use CFC-free products as approved by Rwanda Standards Board.

Remember the facts...

- Oxygen gas can be prepared in the laboratory by:
 - i) Heating nitrates of group I metals.
 - ii) Decomposition of hydrogen peroxide by use of manganese dioxide as a catalyst.

- iii) Decomposition of oxides of heavy metals for example lead (IV) oxide.
- iv) Heating potassium permanganate.
- v) Heating potassium chlorate.
- The four major methods of collecting gases are:
 - i) Over water collection
 - ii) Down ward delivery method
 - iii) Upward delivery method
 - iv) By liquefaction or freezing
- Oxygen gas reacts with both metals and non-metals.
- Oxygen is used in respiration and burning.
- Ozone layer is very important since it prevents the harmful UV rays from reaching the earth.

Test Your Competence 13

1. The following set-up of apparatus can be used in the laboratory to prepare oxygen gas. Study it and answer the questions that follow.

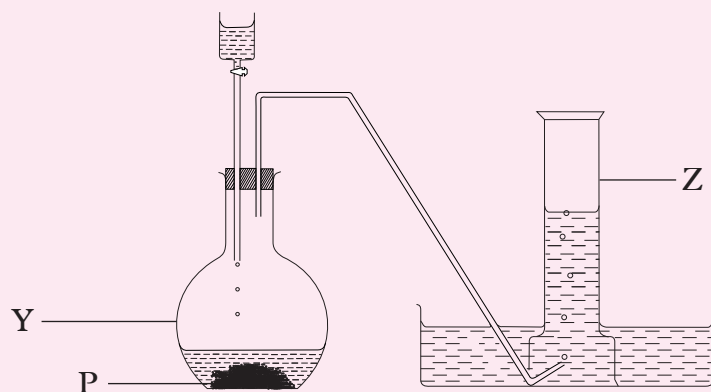

- a) (i) Name the substances which could be used, as solid P.
(ii) Name apparatus Y and Z.
- b) (i) State one property of oxygen from the method of collection.
(ii) What name is given to this method of gas collection?
- c) (i) Describe how you would confirm the presence of oxygen in apparatus Z.
(ii) State three uses of oxygen gas.
2. (a) Write balanced symbolic equations to show the formation of the following compounds from the constituent elements.
(i) MgO (ii) Fe₂O₃
- (b) A burning piece of sodium metal on a deflagrating spoon was lowered into a gas jar of oxygen as shown in the diagram below.

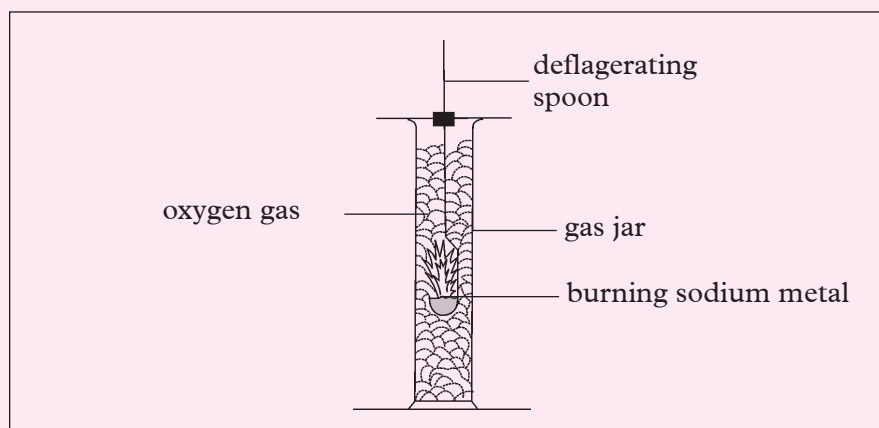

- (i) State the observations made in the gas jar.
(ii) Moist blue and red pieces of litmus paper were introduced into the jar. State and explain the observations made.

- (iii) Write a symbolic chemical equation for the reaction that occurred.
3. (a) Write the molecular formula of ozone.
 (b) Ozone is the best sunscreen. Discuss.
 (c) Name one component of CFC that cause ozone depletion.
4. The following diagrams represent some methods which can be used to collect various gases in the laboratory.

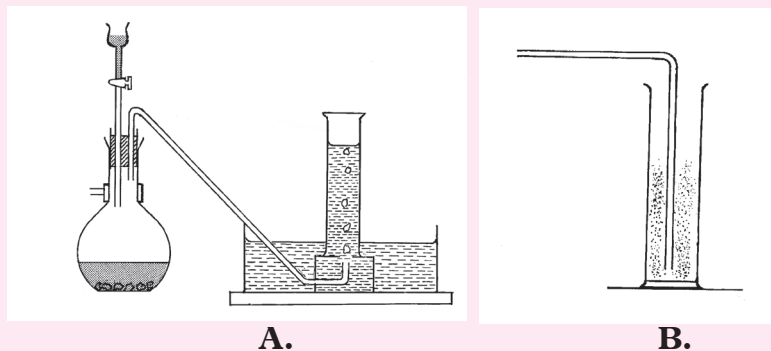

- (a) Identify the two methods of gas collection.
 (b) Name the gases that can be collected as shown in A and B.
 (c) State at least one property of the gases collected by each of the two methods.
5. (a) What fraction of air is oxygen?
 (b) Which component of air has the highest percentage?
6. The diagram below shows an experiment to determine conditions under which iron rusts.

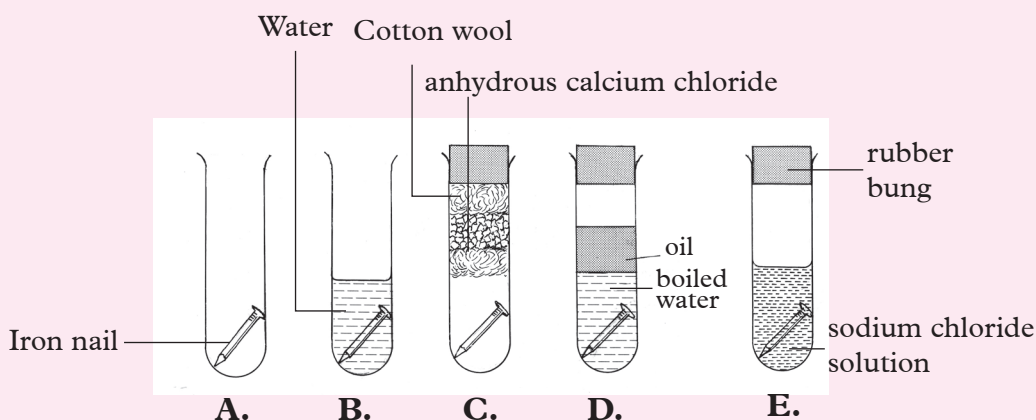

- (a) State the reason for using boiled water in tube D.
 (b) State the purpose of the layer of oil in tube D.
 (c) What is the effect of anhydrous calcium chloride in tube C?
 (d) State what happens to the nails in tube A.
 (e) From this experiment, state two conditions necessary for rusting to take place.

7. (a) Name the product of burning sulphur in oxygen.
(b) Account for the effects of the product formed in 7(a) above to the atmosphere.
8. Explain why mountain climbers and deep-sea divers need to have cylinders of oxygen.

Appendices

Appendix I

Atomic numbers and relative atomic masses of some elements

Element	Symbol	Atomic number (N)	Relative Atomic Mass(RAM)
Aluminium	Al	13	27
Argon	Ar	18	40
Barium	Ba	56	137
Beryllium	Be	4	9
Boron	B	5	11
Bromine	Br	35	80
Calcium	Ca	20	40
Carbon	C	6	12
Chlorine	Cl	17	35.5
Chromium	Cr	24	52
Copper	Cu	29	64
Fluorine	F	9	19
Gold	Au	79	197
Helium	He	2	4
Hydrogen	H	1	1
Iodine	I	53	127
Iron	Fe	26	56
Krypton	Kr	36	84
Lead	Pb	82	207
Lithium	Li	3	7
Magnesium	Mg	12	24
Manganese	Mn	25	55
Mercury	Hg	80	201
Neon	Ne	10	20
Nickel	Ni	28	59
Nitrogen	N	7	14

Oxygen	O	8	16
Phosphorus	P	15	31
Potassium	K	19	39
Silicon	Si	14	28
Silver	Ag	47	108
Sodium	Na	11	23
Sulphur	S	16	32
Tin	Sn	50	119
Vanadium	V	23	51
Zinc	Zn	30	65

Appendix II

Valencies of some common radicals

Valency 1		Valency 2		Valency 3	
<i>Radical</i>	<i>Formula</i>	<i>Radical</i>	<i>Formula</i>	<i>Radical</i>	<i>Formula</i>
Ammonium	NH_4^+	Carbonate	CO_3^{2-}	Phosphate	PO_4^{3-}
Hydroxide	OH^-	Sulphate	SO_4^{2-}		
Nitrate	NO_3^-	Sulphite	SO_3^{2-}		
Chloride	Cl^-				
Hydrogen carbonate	HCO_3^-				
Hydrogen sulphide	HSO_4^-				

Appendix IV: The Periodic Table

KEY

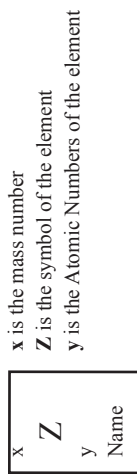
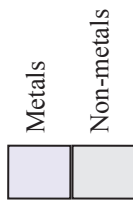

Periodic Table of Elements

Periods	1	2	Transition metals										17	18																		
Groups	1	2	3	4	5	6	7	8	9	10	11	12	13	14	15	16	17	18														
1	1 H Hydrogen																		2 He Helium													
2	3 Li Lithium	4 Be Beryllium																	10 Ne Neon													
3	11 Na Sodium	12 Mg Magnesium																	18 Ar Argon													
4	19 K Potassium	20 Ca Calcium	21 Sc Scandium	22 Ti Titanium	23 V Vanadium	24 Cr Chromium	25 Mn Manganese	26 Fe Iron	27 Co Cobalt	28 Ni Nickel	29 Cu Copper	30 Zn Zinc	31 Ga Gallium	32 Ge Germanium	33 As Arsenic	34 Se Selenium	35 Br Bromine	36 Kr Krypton														
5	37 Rb Rubidium	38 Sr Strontium	39 Y Yttrium	40 Zr Zirconium	41 Nb Niobium	42 Mo Molybdenum	43 Tc Technetium	44 Ru Ruthenium	45 Rh Rhodium	46 Pd Palladium	47 Ag Silver	48 Cd Cadmium	49 In Indium	50 Sn Tin	51 Sb Antimony	52 Te Tellurium	53 I Iodine	54 Xe Xenon														
6	55 Cs Cesium	56 Ba Barium	57 La Lanthanum	58 Ce Cerium	59 Pr Praseodymium	60 Nd Neodymium	61 Pm Promethium	62 Sm Samarium	63 Eu Europium	64 Gd Gadolinium	65 Tb Terbium	66 Dy Dysprosium	67 Ho Holmium	68 Er Erbium	69 Tm Thulium	70 Yb Ytterbium	71 Lu Lutetium	72 Hf Hafnium	73 Ta Tantalum	74 W Tungsten	75 Re Rhenium	76 Os Osmium	77 Ir Iridium	78 Pt Platinum	79 Au Gold	80 Hg Mercury	81 Tl Thallium	82 Pb Lead	83 Bi Bismuth	84 Po Polonium	85 At Astatine	86 Rn Radon
7	87 Fr Francium	88 Ra Radium	89 Ac Actinium	90 Th Thorium	91 Pa Protactinium	92 U Uranium	93 Np Neptunium	94 Pu Plutonium	95 Am Americium	96 Cm Curium	97 Bk Berkelium	98 Cf Californium	99 Es Einsteinium	100 Fm Fermium	101 Md Mendelevium	102 No Nobelium	103 Lr Lawrencium	104 Rf Rutherfordium	105 Db Dubnium	106 Sg Seaborgium	107 Bh Bohrium	108 Hs Hassium	109 Mt Meitnerium	110 Uun Ununium	111 Uuh Ununium	112 Uub Ununium	113 Uut Ununium	114 Uuq Ununium	115 Uup Ununium	116 Uuh Ununium	117 Uus Ununium	118 Uuo Ununium

Lanthanide elements

Actinide elements