

CHEMISTRY

SENIOR 6

Teacher's guide

kigali, January 2019

Copyright
© 2019 Rwanda Education Board
All rights reserved.
This book is the property of Rwanda Education Board.

FOREWORD

Dear teacher,

Rwanda Education Board is honoured to present Senior 6 Chemistry teacher's guide which serves as a guide to competence-based teaching and learning to ensure consistency and coherence in the learning of the chemistry subject. The Rwandan educational philosophy is to ensure that learners achieve full potential at every level of education which will prepare them to be well integrated in society and exploit employment opportunities.

In line with efforts to improve the quality of education, the government of Rwanda emphasizes the importance of aligning teaching and learning materials with the syllabus to facilitate their learning process. Many factors influence what they learn, how well they learn and the competences they acquire. Those factors include the relevance of the specific content, the quality of teachers' pedagogical approaches, the assessment strategies and the instructional materials available. Special attention was paid to the activities that facilitate the learning process in which learners can develop ideas and make new discoveries during concrete activities carried out individually or with peers. With the help of the teachers, learners will gain appropriate skills and be able to apply what they have learnt in real life situations. Hence, they will be able to develop certain values and attitudes allowing them to make a difference not only to their own life but also to the nation.

This is in contrast to traditional learning theories which view learning mainly as a process of acquiring knowledge from the more knowledgeable who is mostly the teacher. In competence-based curriculum, learning is considered as a process of active building and developing of knowledge and understanding, skills and values and attitude by the learner where concepts are mainly introduced by an activity, situation or scenario that helps the learner to construct knowledge, develop skills and acquire positive attitudes and values.

In addition, such active learning engages learners in doing things and thinking about the things they are doing and they are encouraged to bring their own real experiences and knowledge into the learning processes. In view of this, your role is to:

- Plan your lessons and prepare appropriate teaching materials.
- Organize group discussions for learners considering the importance of social constructivism suggesting that learning occurs more effectively when the learner works collaboratively with more knowledgeable and experienced people.
- Engage learners through active learning methods such as inquiry methods, group discussions, research, investigative activities and group and individual work activities.
- Provide supervised opportunities for learners to develop different competences by giving tasks which enhance critical thinking, problem solving, research, creativity and innovation, communication and cooperation.

- Support and facilitate the learning process by valuing learners' contributions in the class activities.
- Guide learners towards the harmonization of their findings.
- Encourage individual, peer and group evaluation of the work done in the classroom and use appropriate competence-based assessment approaches and methods.

To facilitate you in your teaching activities, the content of this teacher's guide is self-explanatory so that you can easily use it. It is divided in 3 parts:

The part 1: Explains the structure of this book and gives you the methodological guidance;

The part 2: Gives the sample lesson plans as reference for your lesson planning process;

The part 3: Provides details the teaching guidance for each concept given in the student book.

Even though this teacher's guide contains the answers for all activities given in the learner's book, you are requested to work through each question and activity before judging learner's findings.

I wish to sincerely appreciate all people who contributed towards the development of this teacher's guide, particularly REB staff who organized the whole process from its inception. Special gratitude goes to the University of Rwanda which provided experts in design and layout services, illustrations and image anti-plagiarism, lecturers and teachers who diligently worked to successful completion of this book. Any comment or contribution would be welcome for the improvement of this textbook for the next edition.

Dr. NDAYAMBAJE Irénée

Director General of Rwanda Education Board

ACKNOWLEDGEMENT

I wish to express my appreciation to all the people who played a major role in development of this Chemistry textbook for senior six. It would not have been successful without active participation of different education stakeholders.

I owe gratitude to different Universities and schools in Rwanda that allowed their staff to work with REB in the in-house textbooks production project. I wish to extend my sincere gratitude to lecturers, teachers and all other individuals whose efforts in one way or the other contributed to the success of writing of this textbook.

Special acknowledgement goes to the University of Rwanda which provided experts in design and layout services, illustrations and image anti-plagiarism.

Finally, my word of gratitude goes to the Rwanda Education Board staff particularly those from the Curriculum, Teaching and Learning Resources Department (CTLRD) who were involved in the whole process of in-house textbook writing.

Joan MURUNGI,

Head of Curriculum, Teaching and Learning Resources Department

TABLE OF CONTENTS

FOREWORD	III
ACKNOWLEDGEMENT	V
1.0. About the Methodological Guidance	XII
1.1. The structure of the guide	XII
1.2. Methodological guidance	XIV
PART II: SAMPLE LESSON PLAN	XXVI
UNIT1: PROPERTIES AND USES OF TRANSITION	1
METALS	1
1.1. Key unit competence	1
1.2. Prerequisite knowledge and skills	1
1.3. Cross-cutting issues to be addressed	1
1.4. Guidance on the introductory activity	2
1.5. List of lessons/sub-heading	3
1.6. Summary of the unit	27
1.7. Additional information for teachers	28
1.8. End unit assessment	31
1.9. Additional Activities	33
UNIT2: EXTRACTION OF METALS	39
2.1. Key unit competence	39
2.2. Prerequisite knowledge and skills	39
2.3. Cross-cutting issues to be addressed	39
2.4. Guidance on the introductory activity	40
2.5. List of lessons/sub-heading	42
2.6. Summary of the unit	59
2.7. Additional information for teachers	61
2.8. End unit assessment	62
2.9. Additional activities	65
UNIT3: NPK AS COMPONENTS OF FERTILIZERS	69

3.1. Key unit competence	69
3.2. Prerequisite (knowledge, skills, attitudes and values)	69
3.3. Cross-cutting issues to be addressed	69
3.4. Guidance on the introductory activity:	71
3.5. List of lessons/sub-heading	71
3.6. Summary of the unit	80
3.7. Additional Information for teachers	80
3.8. End unit assessment	82
UNIT4: BENZENE	87
4.1. Key unit competence:	87
4.2. Prerequisite knowledge and skills	87
4.3. Cross-cutting issues to be addressed	87
4.4. Guidance on the introductory activity	88
4.5. List of lessons	91
4.6. Summary of the unit	103
4.7. Additional information for teachers	103
4.8. End unit assessment	104
4.9. Additional activities	107
UNIT5: DERIVATIVES OF BENZENE	113
5.1. Key unit competence	113
5.2. Prerequisite knowledge and skills	113
5.3. Cross-cutting issues to be addressed	113
5.4. Guidance on the introductory activity	113
5.5. List of lessons/sub-heading	115
5.7. Summary of the unit	124
5.8. Additional Information for teachers	124
5.9. End unit assessment Answers	125
5.10. Additional activities	128
6.1. Key unit competence	133
6.2. Prerequisite knowledge and skills	133
6.3. Cross-cutting issues to be addressed	133
UNIT6: POLYMERS AND POLYMERIZATION	133

6.4. Guidance on the introductory activity	135
6.5. List of lessons/sub-heading	136
6.6. Summary of the unit	151
6.7. Additional information for teachers	152
6.8: End unit assessment	153
6.9. Additional activities	154
UNIT7: SOLVENT EXTRACTION AND COLLIGATIVE PROPERTIES	159
7.1 Key unit competency:	159
7.2 Prerequisite	159
7.3 Cross-cutting issues to be addressed	159
7.4 Guidance on introductory activity	160
7.5 List of Lessons	161
7.6 Summary of the Unit	172
7.7 Additional information for teacher	172
7.8 Answers to end unit Assessment	176
7.9. Additional Activities	180
UNIT8: QUANTITATIVE CHEMICAL EQUILIBRIUM	187
8.1. Key unit competency	187
8.2. Prerequisite knowledge and skills	187
8.3. Cross-cutting issues to be addressed	187
8.4. Guidance on the introductory activity:	187
8.5. List of lessons	189
8.6. Summary of the unit	200
8.7. Additional information	202
8.8. End of unit assessment	202
8.9 Additional activities	204
UNIT9: pH OF ACIDIC AND ALKALINE SOLUTIONS	213
9.1. Key unit competence	213
9.3. Cross-cutting issues to be addressed	213
9.4. Guidance on the introductory activity:	214
9.5. List of lessons	215

9.6. Summary of the unit	240
9.7. Additional information for teachers	241
9.8. End unit assessment	242
9.9. Additional activities	246
UNIT 10 INDICATORS AND TITRATION CURVES	251
10.1. Key unit competence	251
10.2. Prerequisites	251
10.3. Cross-cutting issues to be addressed	251
10.4. Guidance on the introductory activity	252
10.5. List of lessons	252
10.6. Summary of the unit	256
10.7. Additional information for teachers	257
10.8. End unit assessment	257
10.9. Additional activities	257
UNIT 11 SOLUBILITY AND SOLUBILITY PRODUCT OF SPARINGLY SOLUBLE SALTS	267
11.1. Key unit competence	267
11.2. Prerequisite	267
11.3. Cross-cutting issues to be addressed	267
11.4. Guidance on introductory activity	268
11.5. List of lessons	268
11.6. Summary of the unit	283
11.7. Additional information for teachers	284
11.8. End unit assessment	285
11.9. Additional activities	286
UNIT 12 ELECTROCHEMICAL CELL AND APPLICATIONS	295
12.1. Key unit competency	295
12.2. Prerequisite	295
12.4. Guidance on the introductory activity	296
12.5. List of lessons/subheadings	298
12.6. Summary of the unit	316

12.7. Additional information for teachers	318
12.8. End unit assessment (Answers)	322
12.9. Additional activities	325
UNIT 13 FACTORS THAT AFFECT THE RATE OF REACTIONS	335
13.1. Key unit competency:	335
13.2. Prerequisite knowledge and skills	335
13.3. Cross-cutting issues to be addressed	335
13.5. List of lessons/sub-heading	336
13.6. Summary of the unit	340
13.7. Additional Information	341
13.8. End unit assessment Answers	342
13.9. Additional activities	343
UNIT 14 RATE LAWS AND MEASUREMENTS	345
14.1. Key unit competency:	345
14.2. Prerequisite (knowledge, skills, attitudes and values)	345
14.3. Cross-cutting issues to be addressed	345
14.4. Guidance on the introductory activity	346
14.5. List of lessons/sub-heading	348
14.6. Summary of the unit	360
14.7. Additional Information	362
14.8. Solutions of end unit assessment	366
UNIT 15 RADIOACTIVITY	391
15.1. Key unit competence	391
15.2. Prerequisite knowledge and skills	391
15.3. Cross-cutting issues to be addressed	391
15.4. Guidance on the introductory activity:	394
15.5. List of lessons/sub-heading	397
15.6. Summary of the unit	411
15.7. Additional information for teachers	413
15.8. End unit assessment	415
15.9. Additional Activities	418
REFERENCES	421

1.0. About the Methodological Guidance

This document is a Methodological Guidance for Chemistry Senior six in advanced level. It is designed to accompany senior six “Content and Activities for Chemistry S6 – Experimental Version” which is referred to in this guidance as Student’s Book. The Methodological guidance intends to help teachers in the implementation of competence based curriculum specifically S6 Chemistry syllabus.

As the name says, it is a guide that teachers can refer to when preparing their lessons. Teachers may prefer to adopt the guidance provided but they are also expected to be more creative and consider their specific classes’ contexts and prepare accordingly.

1.1. The structure of the guide

This section presents the overall structure, the unit and sub-heading structure to help teachers to understand the different sections of this guide and what they will find in each section.

Overall structure

The whole guide has three main parts as follows:

Part I: General Introduction.

This part provides general guidance on how to develop the generic competences, how to integrate cross cutting issues, how to cater for learners with special educational needs, active methods and techniques of teaching chemistry and guidance on assessment.

Part II: Sample lesson plan

This part provides a sample lesson plan, developed and designed to help the teacher develop their own lesson plans.

Part III: Unit development

This is the core part of the guide. Each unit is developed following the structure below. The guide ends with references.

Structure of a unit

Each unit is made of the following sections:

- **Unit title:** from the syllabus
- **Key unit competence:** from the syllabus
- **Prerequisites (knowledge, skills, attitudes and values)**

This section indicates knowledge, skills and attitudes required for the success of the unit. The competence-based approach calls for connections between units/topics within a subject and interconnections between different subjects. The teacher will find

an indication of those prerequisites and guidance on how to establish connections.

Cross-cutting issues to be addressed

This section suggests cross cutting issues that can be integrated depending on the unit content. It provides guidance on how to come up with the integration of the issue. Note that the issue indicated is a suggestion; teachers are free to take another cross-cutting issue taking into consideration the learning environment.

Guidance on the introductory activity :

Each unit starts with an introductory activity in the learner's book. This section of the teacher's guide provides guidance on how to conduct this activity and related answers. Note that learners may not be able to find the right solution but they are invited to predict possible solutions or answers. Solutions are provided by learners gradually through discovery activities organized at the beginning of lessons or during the lesson.

List of lessons/sub-heading

This section presents in a table suggestion on the list of lessons, lesson objectives copied or adapted from the syllabus and duration for each lesson. Each lesson /subheading is then developed.

End of each unit

At the end of each unit the teacher's guide provides the following sections:

- Summary of the unit which provides the key points of content developed in the student's book.
- Additional information which provides additional content compared to the student's book for the teacher to have a deeper understanding of the topic.
- End unit assessment which provides the answers to questions of end unit assessment in the textbook and suggests additional questions and related answers to assess the key unit competence.
- Additional activities: remedial, consolidation and extended activities. The purpose of these activities is to accommodate each learner (slow, average and gifted) based on end unit assessment results.

Structure of a lesson/sub heading

Each lesson/sub-heading is made of the following sections:

Lesson Sub heading title 1:

- Prerequisites/Revision/Introduction:

This section gives a clear instruction to teacher on how to start the lesson

- Teaching resources

This section suggests the teaching aids or other resources needed in line with the activities to achieve the learning objectives. Teachers are encouraged to replace the suggested teaching aids by the available ones in their respective schools and based on learning environment.

- Learning activities

This section provides a short description of the methodology and any important aspect to consider. It provides also answers to learning activities with cross reference to textbook.

Exercises/Checking up

This provides answers for exercises/ checking up/

1.2. Methodological guidance

1.2.1. Developing competences

Since 2015 Rwanda shifted from a knowledge based to a competence based curriculum for pre-primary, primary and general secondary education. This called for changing the way of learning by shifting from teacher centered to a learner centered approach. Teachers are not only responsible for knowledge transfer but also for fostering student’s learning achievement, and creating safe and supportive learning environment. It implies also that a learner has to demonstrate what he/she is able to do using the knowledge, skills, values and attitude acquired in a new or different or given situation.

The competence-based curriculum employs an approach of teaching and learning based on discrete skills rather than dwelling on only knowledge or the cognitive domain of learning. It focuses on what learner can do rather than what learners know. Learners develop basic competences through specific subject unit competences with specific learning objectives broken down into knowledge, skills and attitudes. These competences are developed through learning activities disseminated in learner-centered rather than the traditional

didactic approach. The student is evaluated against set standards to achieve before moving on.

In addition to specific subject competences, learners also develop generic competences which are transferable throughout a range of learning areas and situations in life. Below are examples of how generic competences can be developed in Chemistry:

Generic competence	Examples of activities that develop generic competences
Critical thinking	<ul style="list-style-type: none"> • Classifying aromatic compounds • Observe, record, interpret data recorded during experiments • Choose the best reagent to test for a substance or to distinguish substances
Research and Problem solving	<ul style="list-style-type: none"> • Research using internet or books from the library • Design a project for making fertilisers • Design a questionnaire for data collection during field visit
Innovation and creativity	<ul style="list-style-type: none"> • Create an experiment procedure to prove a point • Develop a graph to illustrate information • Design a data collection survey/questionnaire • Conduct experiments with objectives, methodology, observations, results, conclusions • Identify local problems and ways to resolve them
Cooperation, Personal and Interpersonal management and life skills	<ul style="list-style-type: none"> • Work in Pairs • Small group work • Large group work

Communication	<ul style="list-style-type: none"> • Organise and present in writing and verbally a complete and clear report of an experiment • Observe, record, interpret the results of a measurement accurately. • Select and use appropriate formats and presentations, such as tables, graphs and diagrams.
Lifelong learning	Exploit all opportunities available to improve on knowledge and skills. Reading scientific journals to keep updated.

1.2.2 Addressing cross cutting issues

Among the changes in the competence based curriculum is the integration of cross cutting issues as an integral part of the teaching learning process-as they relate to and must be considered within all subjects to be appropriately addressed. The eight cross cutting issues identified in the national curriculum framework are: genocide studies, environment and sustainability, gender, Comprehensive Sexuality Education (CSE), Peace and Values Education, Financial Education, standardization Culture and Inclusive Education.

Some cross cutting issues may seem specific to particular learning areas or subjects but the teacher need to address all of them whenever an opportunity arises. In addition, learners should always be given an opportunity during the learning process to address these cross cutting issues both within and out of the classroom so as to progressively develop related attitudes and values.

Below are examples on how crosscutting issues can be addressed in Chemistry:

Cross-cutting issue	Examples on how to integrate the cross-cutting issue
Inclusive education	Involve all learners in all activities without any bias. Eg: allow a learner with physical disability (using wheelchair) to take notes or lead the team during an experiment.
Gender	Involve both girls and boys in all activities: No activity is reserved only to girls or boys. Teachers should ensure equal participation of both girls and boys during experiments as well as during cleaning and tidying up related activities after experiments.

Peace and Values Education	During group activities, debates and presentations, the teacher will encourage learners to help each other and to respect opinions of colleagues.
Standardization culture	Some lessons involve carrying out experiments. Instructions should be clear for learners to always check if they are not using expired chemicals or defective apparatus. In addition, when performing experiments learners have to record data accurately. For tasks involving calculations, they have to always present accurate results.
Environment and sustainability	In order to avoid the environment pollution, before, during or after experiments learners avoid throwing away chemicals anywhere; special places or appropriate containers should be used. Learners also have to be aware of the impacts of the use of aromatic compounds as fuels, fertilizers, metals, plastics, etc on the environment.
Financial Education	When performing experiments, learners avoid waste of chemicals: they have to use the amounts that are just required.

1.2.3. Attention to special needs in the classroom

In the classroom, students learn in different way depending to their learning pace, needs or any other special problem they might have. However, the teacher have the responsibility to know how to adopt his/her methodologies and approaches in order to meet the learning need of each student in the classroom. Also teachers need to understand that student with special needs, need to be taught differently or need some accommodations to enhance the learning environment. This will be done depending to the subject and the nature of the lesson.

In order to create a well-rounded learning atmosphere, teachers need to:

- Remember that children learn in different ways so they have to offer a variety of activities (e.g. role-play, music and singing, word games and quizzes, and outdoor activities)
- Maintain an organized classroom and limits distraction. This will help students with special needs to stay on track during lesson and follow instruction easily.
- Vary the pace of teaching to meet the needs of each child. Some children process information and learn more slowly than others.
- Break down instructions into smaller, manageable tasks. Students with special needs often have difficulty understanding long-winded or several instructions

at once. It is better to use simple, concrete sentences in order to facilitate them understand what you are asking.

- Use clear consistent language to explain the meaning (and demonstrate or show pictures) if you introduce new words or concepts.
- Make full use of facial expressions, gestures and body language.
- Pair a child who has a disability with a friend. Let them do things together and learn from each other. Make sure the friend is not over protective and does not do everything for the child. Both children will benefit from this strategy
- Use multi-sensory strategies. As all children learn in different ways, it is important to make every lesson as multi-sensory as possible. Students with learning disabilities might have difficulty in one area, while they might excel in another. For example, use both visual and auditory cues.

Below are general strategies related to each main category of disabilities and how to deal with every situation that may arise in the classroom. However, the list is not exhaustive because each child is unique with different needs and that should be handled differently.

Strategy to help student with developmental impairment:

- Use simple words and sentences when giving instructions.
- Use real objects that the student can feel and handle. Rather than just working abstractly with pen and paper.
- Break a task down into small steps or learning objectives. The student should start with an activity that s/he can do already before moving on to something that is more difficult.
- Gradually give the student less help.
- Let the student work in the same group with those without disability.

Strategy to help student with visual impairment:

- Help children to use their other senses (hearing, touch, smell and taste) to play and carry out activities that will promote their learning and development.
- Use simple, clear and consistent language.
- Use tactile objects to help explain a concept.
- If the child has some sight, ask them what they can see. Get information from parents/caregivers on how the child manages their remaining sight at home.
- Make sure the child has a group of friends who are helpful and who allow the child to be as independent as possible.
- Plan activities so that children work in pairs or groups whenever possible

Strategy to help student with hearing impairment:

- Strategies to help children with hearing disabilities or communication difficulties
- Always get the child's attention before you begin to speak.
- Encourage the child to look at your face.
- Use gestures, body language and facial expressions.
- Use pictures and objects as much as possible.
- Ask the parents/caregivers to show you the signs they use at home for communication use the same signs yourself and encourage other children to also use them.
- Keep background noise to a minimum.

Strategies to help children with physical disabilities or mobility difficulties:

- Adapt activities so that children who use wheelchairs or other mobility aids, or other children who have difficulty moving, can participate.
- Ask parents/caregivers to assist with adapting furniture e.g. The height of a table may need to be changed to make it easier for a child to reach it or fit their legs or wheelchair under.
- Encourage peer support friends can help friends.
- Get advice from parents or a health professional about assistive devices.

1.2.4. Guidance on assessment

Assessment is an integral part of teaching and learning process. The main purpose of assessment is for improvement. Assessment for learning/ **Continuous/ formative assessment** intends to improve learners' learning and teacher's teaching whereas assessment of learning/summative assessment intends to improve the entire school's performance and education system in general.

Continuous/ formative assessment

It is an ongoing process that arises out of interaction during teaching and learning process. It includes lesson evaluation and end of sub unit assessment. This formative assessment should play a big role in teaching and learning process. The teacher should encourage individual, peer and group evaluation of the work done in the classroom and uses appropriate competence-based assessment approaches and methods.

In Senior six Chemistry textbook, formative assessment principle is applied through checking up activities that are planned in each lesson to ensure that lesson objectives are achieved before moving on. At the end of each unit, the end unit assessment is formative when it is done to give information on the progress of students and from there decide what adjustments need to be done. Assessment standards are taken into consideration when setting tasks.

Summative assessment:

The assessment done at the end of the term, end of year, is considered as summative. The teacher, school and parents are informed on the achievement of educational objectives and think of improvement strategies. There is also end of level/ cycle assessment in form of national examinations.

1.2.5. Students' learning styles and strategies to conduct teaching and learning process

There are different teaching styles and techniques that should be catered for. The selection of teaching method should be done with the greatest care and some of the factors to be considered are: the uniqueness of subjects; the type of lessons; the particular learning objectives to be achieved; the allocated time to achieve the objective; instructional available materials; the physical/ sitting arrangement of the classroom, individual students' needs, abilities and learning styles.

There are mainly four different learning styles as explained below:

a. Active and reflective learners

Active learners tend to retain and understand information best by doing something active with it, discussing or applying it or explaining it to others. Reflective learners prefer to think about it quietly first.

b. Sensing and intuitive learners

Sensing learners tend to like learning facts; intuitive learners often prefer discovering possibilities and relationships. Sensors often like solving problems by well-established methods and dislike complications and surprises; intuitive learners like innovation and dislike repetition.

c. Visual and verbal learners

Visual learners remember best what they see—pictures, diagrams, flow charts, time lines, films, demonstrations, etc.; verbal learners get more out of words—written and spoken explanations.

d. Sequential and global learners

Sequential learners tend to gain understanding in linear steps, with each step following logically from the previous one. Global learners tend to learn in large jumps, absorbing material almost randomly without seeing connections, and then suddenly “getting it.”

1.2.6.. Teaching methods and techniques that promote the active learning

The different student learning styles mentioned above can be catered for, if the teacher uses active learning whereby learners are really engaged in the learning process.

What is Active learning?

Active learning is a pedagogical approach that engages students in doing things and thinking about the things they are doing. In active learning, learners are encouraged to bring their own experience and knowledge into the learning process.

The role of the teacher in active learning

- The teacher engages learners through active learning methods such as inquiry methods, group discussions, research, investigative activities and group and individual work activities.
- He/she encourages individual, peer and group evaluation of the work done in the classroom and uses appropriate competence-based assessment approaches and methods.
- He provides supervised opportunities for learners to develop different competences by giving tasks which enhance critical thinking, problem solving, research, creativity and innovation, communication and cooperation.
- Teacher supports and facilitates the learning process by valuing learners' contributions in the class activities.

The role of learners in active learning

Learners are key in the active learning process. They are not empty vessels to fill but people with ideas, capacity and skills to build on for effective learning. A learner engaged in active learning:

- Communicates and shares relevant information with other learners through presentations, discussions, group work and other learner-centred activities (role play, case studies, project work, research and investigation)
- Actively participates and takes responsibility for their own learning
- Develops knowledge and skills in active ways
- Carries out research/investigation by consulting print/online documents and resourceful people, and presents their findings
- Ensures the effective contribution of each group member in assigned tasks through clear explanation and arguments, critical thinking, responsibility and confidence in public speaking
- Draws conclusions based on the findings from the learning activities.

Some active techniques that can be used in Chemistry

The teaching methods strongly emphasised in the competence Based Curriculum (CBC) are active methods. Below are some active techniques that apply in sciences:

- **Practical work/ experiments:**

Many of the activities suggested in the chemistry curriculum as well as in the student's book are practical work or experiments.

Practical work is vital in learning chemistry; this method gives the learner the opportunity to implement a series of activities and leads to the development of both cognitive and hands-on skills. The experiments and questions given should target the development of the following skills in students: observation; recording and report writing; manipulation; measuring; planning & designing.

A practical lesson/Experiment is done in three main stages:

- **Preparation:** Checking materials to ensure they are available and at good state; try the experiment before the lesson; think of safety rules and give instructions to lab technician if you have any.
- **Performance:** sitting or standing arrangement of students; introduction of the experiment: aims and objectives; setting up the apparatus; performing the experiment; write and record the data.
- **Discussion:** observations and interpreting data; make generalizations and assignment: writing out the experiment report and further practice and research.

In some cases, demonstration by the teacher is recommended when for example the experiment requires the use of sophisticated materials or very expensive materials or when safety is a major factor like dangerous experiments and it needs specific skills to be learnt first.

In case your school does not have enough laboratory materials and chemicals, experiments can be done in groups but make sure every student participates. In case your school does not have materials make arrangements with the neighbouring science school of excellence and take your students there for a number of experiments.

- **Research work**

Each learner or group of learners is given a research topic. They have to gather information from internet, available books in the library or ask experienced people and then the results are presented in verbal or written form and discussed in class.

- **Project work**

Chemistry teachers are encouraged to sample and prepare project works and engage their students in, as many as possible. Learners in groups or individually, are engaged in a self-directed work for an extended period of time to investigate and respond to a complex question, problem, or challenge. The work can be presented to classmates or other people beyond the school. Projects are based on real-world problems that capture learners' interest. This technique develops higher order thinking as the learners acquire and apply new knowledge in a problem-solving context.

- **Field trip**

One of the main aims of teaching chemistry in Rwanda is to apply its knowledge for development. To achieve this aim we need to show to students the relationship between classroom chemistry lessons and applied chemistry. This helps them see the link between chemical principles and technological applications.

To be successful, the field visit should be well prepared and well exploited after the visit:

Before the visit the teacher and learners:

- agree on aims and objectives
- gather relevant information prior to visit
- brainstorm on key questions and share responsibilities
- discuss materials needed and other logistical and administrative issues ;
- discuss and agree on accepted behaviours during the visit
- Visit the area before the trip if possible to familiarise yourself with the place.

After the visit, when students come back from trip, the teacher should plan for follow-up. The follow-up should allow students to share experiences and relate them to the prior chemistry knowledge. This can be done in several ways; Either: Students write a report individually or in groups and give to the teacher for marking. The teacher then arranges for discussion to explain possible misconceptions and fill gaps. Or: Students write reports in groups and display them on the class notice board for everyone to read.

Main steps for a lesson in active learning approach

All the principles and characteristics of the active learning process highlighted above are reflected in steps of a lesson as displayed below. Generally the lesson is divided into three main parts whereby each one is divided into smaller steps to make sure that learners are involved in the learning process. Below are those main part and their small steps:

a. Introduction

Introduction is a part where the teacher makes connection between the current and previous lesson through appropriate technique. The teacher opens short discussions to encourage learners to think about the previous learning experience and connect it with the current instructional objective. The teacher reviews the prior knowledge, skills and attitudes which have a link with the new concepts to create good foundation and logical sequencings.

b. Development of the new lesson

The development of a lesson that introduces a new concept will go through the following small steps: discovery activities, presentation of learners' findings, exploitation, synthesis/summary and exercises/checking up, explained below:

- Discovery activity

Step 1

- The teacher discusses convincingly with students to take responsibility of their learning
- He/she distributes the task/activity and gives instructions related to the tasks (working in groups, pairs, or individual to instigate collaborative learning, to discover knowledge to be learned)

Step 2

- The teacher let the students work collaboratively on the task.
- During this period the teacher refrains to intervene directly on the knowledge
- He/she then monitors how the students are progressing towards the knowledge to be learned and boost those who are still behind (but without communicating to them the knowledge).

Presentation of learners' productions

- In this episode, the teacher invites representatives of groups to presents the students' productions/findings.
- After three/four or an acceptable number of presentations, the teacher decides to engage the class into exploitation of the students' productions.

Exploitation of learner's productions

- The teacher asks the students to evaluate the productions: which ones are correct, incomplete or false
- Then the teacher judges the logic of the students' products, corrects

those which are false, completes those which are incomplete, and confirms those which correct.

Institutionalization (summary/conclusion/ and examples)

The teacher summarizes the learned knowledge and gives examples which illustrate the learned content.

Exercises/Application activities

- Exercises of applying processes and products/objects related to learned unit/sub-unit
- Exercises in real life contexts
- Teacher guides learners to make the connection of what they learnt to real life situations. At this level, the role of teacher is to monitor the fixation of process and product/object being learned.

c. Assessment

In this step the teacher asks some questions to assess achievement of instructional objective. During assessment activity, learners work individually on the task/activity. The teacher avoids intervening directly. In fact, results from this assessment inform the teacher on next steps for the whole class and individuals. In some cases the teacher can end with a homework assignment.

: SAMPLE LESSON PLAN

School Name:Teacher's name:

Term	Date	Subject	Class	Unit N ^o	Lesson N ^o	Duration	Class size
	... /... / 2018	CHEMISTRY	S6	1	1 of 1	40 min	48
Type of Special Educational Needs to be catered for in this lesson and number of learners in each category				Slow learners (6)			
Unit title		Properties and uses of transition metals					
Key Unit Competence:		The learner should be able to explain the properties and uses of transition metals.					
Title of the lesson		Definition and electronic configuration of transition metals					
Instructional Objective		Using the portion of the periodic table provided, learners will correctly write the electron configurations of elements from Sc to Zn.					
Plan for this Class (location: in / outside)		In the classroom					
Learning Materials (for ALL learners)		Periodic table of elements, worksheets or books; projectors and/or chalkboard					
References		1) Ramsden. E.N (2000), 4 th edition. A-level chemistry. Nelson thornes, UK 2) Ritchie, D. G. (2008). <i>OCR Chemistry A2</i> . Harlow: Heinemann.					

Timing for each step	Description of teaching and learning activity		Generic competences and cross cutting issues to be addressed + a short explanation
	Teacher's activities	Learners' activities	
	In groups, using the portions of the periodic table provided on worksheets, and by answering different questions asked, learners will discuss and write the electronic configurations of the transition metals from Sc to Zn.		
1. Introduction 5 min	Ask students to form groups of four students (Note: remember to put slow learners with quick learners).	-Form groups (4 members each) as requested by the teacher - follow teacher's instructions - organize themselves in their respective groups	Generic competences Critical thinking: students have to analyse the questions critically in order

	Distribute worksheets with activities to be performed. Ask questions from activity 1.1, question number one for revision. This has been done randomly.	- individually, try to answer the questions in Activity 1.1 , question number one (revision): 1. Write the electron configuration of the following atoms and ions: Ca (Z=11) Ca ²⁺ Na (Z=11), Na ⁺ Expected answers: a) $1s^2 2s^2 2p^6 3s^2 3p^6 4s^2$ b) $1s^2 2s^2 2p^6 3s^2 3p^6$ c) $1s^2 2s^2 2p^6 3s^1$ d) $1s^2 2s^2 2p^6$	to discover the electron configuration of Cr and Cu Cross cutting issues Environmental sustainability: -During their mining, the space should be filled with soil again to avoid land sliding, development of mosquitoes which can cause malaria -Some transition metals are harmful to human (e.g mercury) Standardisation culture:
--	--	---	--

2. Development of the lesson			
2.1 Discovery activity 10 min	Let learners work collaboratively in their groups by answering questions provided in activity 1.1	- Discuss, in groups of 4, on the questions provided in activity 1.1, questions 2 and 3 from the student book. 2. Referring to the portion of periodic table in this book, a) Write the electron configuration of the elements from Sc to Zn. b) Point out any difference between the electron configuration of the above elements and that of other elements in s and p blocks	Peace and values education Cooperation , respect, love for others through discussions Connection through social interaction Caring while guiding learners Attentive listening
		3. Define the term transition metal.	through group members discussion and Responsibility by leading group activity
2.2 Presentation of learner's productions 10 min	Invite 5 students from different groups to write the electron configuration of the provided substances (at the same time) Note down some key words while students are presenting	-Write the electron configuration of the provided substances by the Invited students Expected answers: Expected answers 2. a)	cross cutting issues and competences to be addressed are the ones described above

		Scandium	21	$1s^2 2s^2 2p^6 3s^2 3p^6 4s^2 3d^1$	
		Titanium	22	$1s^2 2s^2 2p^6 3s^2 3p^6 4s^2 3d^2$	
		Vanadium	23	$1s^2 2s^2 2p^6 3s^2 3p^6 4s^2 3d^3$	
		Chromium	24	$1s^2 2s^2 2p^6 3s^2 3p^6 4s^1 3d^5$	
		Manganese	25	$1s^2 2s^2 2p^6 3s^2 3p^6 4s^2 3d^5$	
		Iron	26	$1s^2 2s^2 2p^6 3s^2 3p^6 4s^2 3d^6$	
		Cobalt	27	$1s^2 2s^2 2p^6 3s^2 3p^6 4s^2 3d^7$	
		Nickel	28	$1s^2 2s^2 2p^6 3s^2 3p^6 4s^2 3d^8$	
		Copper	29	$1s^2 2s^2 2p^6 3s^2 3p^6 4s^1 3d^{10}$	
		Zinc	30	$1s^2 2s^2 2p^6 3s^2 3p^6 4s^2 3d^{10}$	
		b)			
		The electron configuration of main group elements			
		Their electrons end in s or p orbitals			
		Have filled or no occupied d-orbitals			
		3. A transition metal is "an element whose atom has a partially filled d sub-shell, or which can give rise to cations with an incomplete d sub-shell".			
2.3 Exploitation min	Ask the students to comment on the answers given by their colleagues.	- Comment on the answer given by their fellow colleagues - Answer questions asked by the teacher -Write key points		Cross cutting issues and competences to be addressed are the ones	

	<p>Judge students' productions, corrects those which are false, complete those which are incomplete, and confirm those which are correct.</p> <p>Ask some questions to guide slow learners</p>	<p>- Ask questions for clarification</p>	<p>described above.</p>
<p>2.4.Conclusion/ Summary 5 min</p>	<p>- Guide learners in order to find the conclusion through questioning(why some elements have exceptional electron configurations)</p>	<p>-Find the conclusion guided by the teacher When building electronic structure of transition metals, 4s orbital is filled before 3d orbitals.</p> <p>The transition elements are stable when their d-orbitals are filled (d^{10}) or when their d-orbitals are half filled (d^5). This explains the electronic structure of copper, $[\text{Ar}] 4s^1 3d^{10}$ instead of $[\text{Ar}] 4s^2 3d^9$. The same applies for Cr: $[\text{Ar}] 4s^1 3d^5$ and not $[\text{Ar}] 4s^2 3d^4$.</p> <p>In order to attain that stability an electron can jump from 4s orbital to 3d orbital because those two orbitals are close in energy.</p>	<p>cross cutting issues and competences to be addressed are the ones described above</p>

3. Assessment 5 min	<p>Assess the achievement of instructional objective by giving varied exercises including those of ions of transition metals.</p> <p>Take care of slow learners as students mark each other.</p> <p>Inform the learners to make corrections during marking</p>	<p>- Learners work individually</p> <p>Questions: Using Mn (Z = 25), Mg (Z = 12) and Br (Z = 35) as examples, explain the difference between the electron configuration of transition elements and that of main group elements.</p> <p>- students Mark each other</p> <p>Expected answers</p> <p>Mn: $1s^2 2s^2 2p^6 3s^2 3p^6 4s^2 3d^5$ Mg: $1s^2 2s^2 2p^6 3s^2$ Br: $1s^2 2s^2 2p^6 3s^2 3p^6 4s^2 3d^{10} 4p^5$</p> <table border="1" data-bbox="643 772 1030 1038"> <thead> <tr> <th data-bbox="643 772 837 848">transition metals</th> <th data-bbox="837 772 1030 848">main group elements</th> </tr> </thead> <tbody> <tr> <td data-bbox="643 848 837 925">-are found in d-block</td> <td data-bbox="837 848 1030 925">-are in s or p-block</td> </tr> <tr> <td data-bbox="643 925 837 1038">-are all metals</td> <td data-bbox="837 925 1030 1038">-some are metals others are non-metals</td> </tr> </tbody> </table>	transition metals	main group elements	-are found in d-block	-are in s or p-block	-are all metals	-some are metals others are non-metals	<p>Cross cutting issues and competences to be addressed are the ones described above</p>
transition metals	main group elements								
-are found in d-block	-are in s or p-block								
-are all metals	-some are metals others are non-metals								
Observation on lesson delivery	<p>The lesson took place very well where each student tried to participate during the exploitation process. One of the reasons is that the lesson attracts the interest of students from their prior knowledge on electronic configuration in senior four.</p>								

UNIT 1: PROPERTIES AND USES OF TRANSITION METALS

1

1.1. Key unit competence

Explain the properties and uses of transition metals

1.2. Prerequisite knowledge and skills

Students will learn better the properties and uses of transition metals if they have understanding on: electronic configuration, atomic spectra, chemical bonding, chemistry of the elements in the periodic table (main group elements), redox reactions, Lewis acids and bases (all these covered in senior four); nomenclature of inorganic and organic compounds (covered from senior one to senior five)

1.3. Cross-cutting issues to be addressed

Environment and sustainability

Transition metals are among the heavy metals (metals with density greater than $5\text{g}/\text{cm}^3$). Heavy metals consist of both biological essential and non-essential metals. Biological essential heavy metals include copper, nickel, iron and zinc. Although they are necessary, they become toxic at high concentrations.

Heavy metals are a natural part of the earth's crust. They enter the sea usually through riverine influx (after weathering and erosion of rocks), atmospheric deposition (dust particles from volcanoes for instance). Humans add both the riverine deposition (waste water of factories) and atmospheric deposition (cars, factories ...). Heavy metals are stable and cannot be broken down, which makes them to accumulate in the environment.

Transition metals form complexes which are soluble in water. Though they are really important in the human body; their excessiveness causes dangers to the body. And yet most common metallic materials used in daily life are made of transition metals. How are the old ones disposed off? When metals are spread on the ground (this is land pollution in itself), they run into water bodies carried by rain water from mountains through erosion. In water bodies, they dissolve by forming complexes causing its contamination, hence causing water pollution.

Young people should be addressed about this issue so that they can avoid to the dispose

waste materials everywhere. Waste materials should be collected together in areas reserved for them according to their categories. The majority of old materials made of metals can be recycled to form new ones without polluting environment. This will help them to understand the importance of sustainability as they grow up and become responsible for the world around them.

Inclusive education

This unit requires learners to carry out a lot of researches to be able to understand first, then share and discuss on things like structure of benzene, its stability, and so on. This may be challenging to students with special educational needs especially slow learners. However, as teacher you can organise your class and use different strategies to help all learners understand well.

1.4. Guidance on the introductory activity

Introductory activity for unit 1, student's book S6.

Transition metals seem to be new for students but they are familiar with the majority of them such as zinc, manganese, copper...

So, the introduction of this unit to students of senior six would be simple. The introductory activity can attract interest of students as it is built on the materials that are around everywhere. Here is a guide of how this activity can be performed by students guided by the teacher.

- Put your students in groups of 3-4 (or even 5 depending on the size of your class)
- Provide them with books or worksheets with the introductory activity, unit 1 from student's book S6.
- Give them time between 15 and 20 minutes to read, analyze, interpret and discuss about the activity. Here they have to observe and analyse the objects in the pictures and answer the questions asked about them. Let them use books or search from internet in order to discover what they don't discover directly.
- Call one or two groups to present their findings. You may note some key points at this stage.
- Ask other members (randomly) to give their input. Don't worry if some of them fail to reach the exact results. They get to understand as the unit progresses.
- Address your views about their presentations. But it is not necessary to conclude. Just motivate them to create curiosity in them.

1.5. List of lessons/sub-heading

#	Lesson title	Learning objectives	Number of periods
1	Introductory activity		1
2	Definition and electronic configuration of transition metals	Relate the electronic configuration to the definition of a transition metal/element as d-block elements.	1
3	Properties of transition metals	Relate the electronic configurations to special properties of transition metals. Compare the physical properties of transition metals to those of s-block and p-block elements. Predict the shape of complex compounds of transition metal cations. Explain the principle of ligand exchange.	4
4	The anomalous properties of zinc and scandium	Explain why scandium and zinc are not considered as true transition metals.	1
5	Naming of complex ions and isomerism in compounds of transition elements	Apply the rules in naming complex ions. Discuss stereoisomerism among complex ions	3
6	The chemistry of individual metals	Describe reactions of transition metals. State the uses of transition metals.	6
7	Identification of ions transition metals	Perform the confirmatory tests for transition metal ions.	4
8	End unit assessment		2

Lesson 1: Definition and electronic configuration of transition metals

a) Prerequisites/Revision/Introduction:

Students will learn better this lesson if they have knowledge about the electronic configuration of atoms and ions using s, p, d... notation and classification of elements into blocks from the electronic configuration (covered in senior four)

b) Teaching resources

Use periodic table of elements, worksheets or books; projectors and/or chalkboard.

c) Learning activities

Writing of electronic configuration is among simple activities that can be performed successfully by students. Make sure you help each student to do this as something that can make him/her feel proud of chemistry.

Methodological steps:

As a facilitator, you are expected to guide students to learn by doing activity 1.1, as described below:

Activity 1.1, student's book S6

Task one (this concerns question 1)

- Guide students to revise the electronic configuration of atoms and ions by asking them randomly.
- The following are the expected answers:
 - (a) Ca (Z=20): $1s^2 2s^2 2p^6 3s^2 3p^6 4s^2$
 - (b) $(b)Ca^{2+}(18e^-): 1s^2 2s^2 2p^6 3s^2 3p^6$
 - (c) Na (Z=11), $1s^2 2s^2 2p^6 3s^1$
 - (d) $Na^+(10e^-): 1s^2 2s^2 2p^6$

Task 2 (this concerns question 2):

For the remaining questions (question 3 will be answered randomly after writing the electronic configuration)

- Put your students in pairs (or in groups of 3-4)
- Give your students time between 10 and 15 minutes to discuss and write the electronic configurations of the 10 transition metals. Here you need to give them that portion of periodic table from the student's book S6. Don't let them use their own periodic tables because many of them already have electronic configurations of elements. Similarly, they should not use this book for them to appreciate their achievement.

- Divide the chalkboard into 3-4 parts
- Call 3-4 students at the same time write the electronic configurations on the chalk board of any 3 or 4 elements. These elements should include chromium and copper!
- Ask other members to give their comments/ inputs if any.
- Based on learners' production, through questioning, guide them to draw important conclusions. Remember that chromium and copper have exceptional electron structures! At this step you will ask them to define transition metals (question 3) by asking them to state the block to which the elements belong
- The following are the expected answers

2. a) See student's book

b)

The electronic configuration of main group elements	The electronic configuration of transition elements
Their electrons end in s or p orbitals	Their electrons end in d orbitals
Have filled or no occupied d-orbitals	Have unfilled d-orbitals

3. See student's book

- End up with checking up 1.1, in student's book as evaluation.

Answers for Checking up 1.1

1. See the definition and electronic configuration in the Student Book
2. They exhibit transitional behaviour between s-block and p-block elements.

Lesson 2: Properties of transition metals

a) Prerequisites/Revision/Introduction:

Students will learn better all the properties of transition elements if they have knowledge on their electronic configuration (covered in 1.1, this unit); calculation of oxidation states (from redox reaction), atomic spectra and general physical properties of metals (all these were covered in senior four)

b) Teaching resources

Use worksheets or books; projectors and/or chalkboard **materials** such as various metals; beakers, test tubes, test tube holders, spatula, bunsen burners, pair of tongs, match box. **Chemicals** such as various compounds including those of transition metals and their solutions

c) Learning activities

You can start by asking your students questions about the physical properties of metals in general as revision. This lesson contains about nine activities, some of which are practicals. Some of the materials to be used can be brought by students by themselves to increase their participation.

Methodological steps:

As a facilitator, you are expected to guide learners to learn by doing activities from 1.2 (a) to 1.2 (b), as described below:

Activities in 1.2, student's book S6

Activity 1.2 (a)

Before the practical (preparation)

- Try to copy this activity on a sheet and make copies equal to the number of groups (of 4 to 5) that you will form according to your class.
- Make sure you understand well the content (theory) about the practical to be performed so as to help students link it with their observations.
- Try to make the required materials available before your students in the laboratory.

In the practicals

- Start by telling your students to join laboratory tables, forming groups of 4 to 5
- Give them worksheets and ask them to read instructions first.
- Give them time for manipulation (10-15 minutes). Here, they have to follow the instructions provided on worksheets. They have to record their observations making a report to be presented.
- Call two or 3 (or more depending on your time) groups to present their findings. During the presentation, remember to take notes on some key points (correct ones and wrong ones) that are going to guide you in the next step
- Ask members of other groups to give their comments/ inputs if any.
- Based on learners' production, through questioning, guide them to draw important conclusions.
- These are some of the answers you can get from your students:

3. For all the three cases, the s-block element is the first to melt

4. Transition metals have higher melting points than s, p-block elements.

Answers for Checking up 1.2 (a):

See Properties of transition metals in Student book

Activity 1.2 (b)

- As described in activity 1.2 (a), only time may vary
- ANSWERS for Activity 1.2 (b)
 - I. For all the two cases the transition metals will have higher mass.
 - II. See Properties of transition metals in Student's Book.

Answers for Checking up 1.2 (b)

The increase in nuclear charge from 22 to 23 makes the inner clouds of electrons contract, and the radius of the atom decreases.

Activity 1.2 (c)

- Put your students in groups of 3-4
- Give your students time between 5 and 10 minutes to read and analyze the summary (about ionization energy) in the student's book, or any other way (work sheet, projection, books from library, internet, etc) you may have prepared for them.
- Call two or 3 (or more depending on your time) groups to present their findings. During the presentation, remember to take notes on some key points (correct ones and wrong ones) that are going to guide you in the next step
- Ask members of other groups to give their comments/ inputs if any.
- Based on learners' production, through questioning, guide them to draw important conclusions.

ANSWERS to Activity 1.2 (c), See Properties of transition metals in Student book

Answers to Checking up 1.2 (c)

a) The increase in nuclear charge from 26 to 27 is screened by the addition of an extra d- electron

b) The third electron is being removed from a d^6 configuration, that has two electrons in one d-orbital. These two electrons repel each other, making each one easier to be removed.

Activity 1.2 (d)

- As described in activity 1.2 (c), only a slight change can be made
- **Answers for activity 1.2(d)**

- a. See Properties of transition metals in Student book
- b. Transition metals are more stable (or have special stability) when they have filled orbitals or half-filled orbitals. From the above
- i. Elements rearrange to acquire that stability
 - ii. Ions are more stable when they have filled orbitals or half-filled orbitals

Answer for Checking up 1.2 (d)

Mn^{2+} is more stable than Mn^{3+} because it has half-filled d-orbitals

Activity 1.2 (e)

- As described in activity 1.2 (a), only time may vary
- **ANSWERS for Activity 1.2(e)**
It acts as a catalyst

Answers for Checking up 1.2 (e)

See Properties of transition metals in Student book

Activity 1.2 (f)

- One day before, inform your students to look for some of the objects given in the pictures in activity 1.2 (f) and bring them. You need to find magnets for them.
- The next steps involve a combination of those in activity 1.2 (a) and 1.2 (c)
- **ANSWERS to Activity 1.2 (f)**

[1]

Objects attracted by a magnet	Objects not attracted by a magnet
Nail Spoon 100FRW coin Iron sheet	Chalk

[2]

- **Nail:** iron
- **Spoon:** stainless steel
- **100FRW coin:** 100 francs - Nickel-plated steel ring and Copper-plated steel centre
- **1 franc** - 98% Aluminium, 2% Magnesium

- **5 francs** - Bronze
- **10 francs** - Bronze
- **20 francs** - [Nickel-plated steel](#)
- **50 francs** - Nickel-plated steel)
- **Iron sheet:** Iron coated with zinc or aluminium.
- **Chalk stick or chalkboard chalk:** CaCO_3 (or the mineral *gypsum* (*calcium sulphate*))

Answer for Checking up 1.2 (f)

See Properties of transition metals in Student book

Activity 1.2 (g)

- Help learners to obtain these objects by using all possible ways. They are everywhere even in your school. In case of failure, you can download the missing ones to help your students.
- By observing the objects, other steps will be as described in activity 1.2 (c)

Answer for Checking up 1.2 (g):

[1] Because alloys are solids and are formed by mixing one or two elements where at least one is a metal.

[2] refer to student's book

Activity 1.2 (h)

- *As described in activity 1.2 (c), only a slight change can be made*
- **Answers to Activity 1.2 (h)**

Refer to Properties of transition metals in Student book

Answer for Checking up 1.2 (h)

(1) Refer to student's book

(2) and (3) Refer to student's book

Activity 1.2 (i)

- As described in activity 1.2 (a), only time may vary
- ANSWERS to Activity 1.2 (i)
- Experiment 1:
NaCl: white
CaCl₂: White
FeSO₄: green

$\text{Fe}_2(\text{SO}_4)_3$: yellow

KMnO_4 : purple

$\text{K}_2\text{Cr}_2\text{O}_7$: orange

distilled water: colourless

$\text{Cr}_2(\text{SO}_4)_3$: reddish brown

(2) Oxidation state s:

- NaCl : (Na = +1); CaCl_2 : (Ca = +2); FeSO_4 : (Fe = +2); $\text{Fe}_2(\text{SO}_4)_3$: (Fe = +3); KMnO_4 (Mn = +7); $\text{K}_2\text{Cr}_2\text{O}_7$ (Cr = +6); $\text{Cr}_2(\text{SO}_4)_3$ (Cr = +3)

(3) The colors for solutions

NaCl and solution formed: Colourless

FeSO_4 Solution formed: green

KMnO_4 Solution formed: purple

$\text{K}_2\text{Cr}_2\text{O}_7$ Solution formed: orange

$\text{Fe}_2(\text{SO}_4)_3$ Solution formed: yellow

Conclusion: Coloured solutions contain transition metals ions.

Experiment 2:

Points for discussion:

1) The solid anhydrous copper (II) sulphate (white powder) is converted into copper (II) sulphate (pale blue) solution.

2) A pale blue precipitate formed dissolves in excess ammonia to form a deep blue solution.

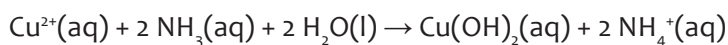

Pale blue precipitate

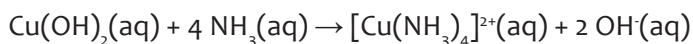

Deep blue solution

3) Pale blue solution turns yellow.

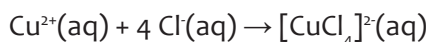

Yellow solution

4) A gas is given off and the test tube became hot.

- Checking up 1.2 (i)

Answers for Checking up 1.2 (i)

- Fe^{2+} : Coloured because the d-orbital is not filled, there are unpaired orbitals.
- Mn^{7+} : Colourless because there is no unpaired orbital.
- K^+ : Colourless because it is not transition metal ion.

Lesson 3: The anomalous properties of zinc and scandium

a. Prerequisites/Revision/Introduction:

Refer to lesson 2

b. Teaching resources

Refer to lesson 2

c. Learning activities

Refer to lesson 2

Methodological steps:

As a facilitator, you are expected to guide learners to learn by doing activity 1.3, as described below:

Activity 1.3, student's book S6

Refer to activity 1.2 (c)

Answers for questions about this activity are in the student's book

Answer for Checking up 1.3

Zinc is diamagnetic while scandium is paramagnetic

Lesson 4: Naming of complex ions and isomerism in compounds of transition elements

a. Prerequisites/Revision/Introduction:

Refer to lesson one in this unit

b. Teaching resources

Use molecular models; worksheets or books; projectors and/or chalkboard

c. Learning activities

You can start by asking your students questions about the structure of benzene

Methodological steps:

As a facilitator, you are expected to guide learners to learn by doing activities 1.4 (a) and 1.4 (b), as described below:

Activity 1.4 (a), student's book S6

In question 1, in activity 1.4 (a), student's book S6,

- Guide students to revise about the nomenclature of compounds in general by asking them randomly.
- The following are the expected answers

a) CaBr_2 : Calcium bromide (The cation is named first, then the anion since the compound is ionic)

b) CCl_4 : Tetrachloromethane (named as halogenoalkane, i.e, halo 'chloro' alkane 'methane' with tetra-/prefix to show the number of substituents) or

Carbon tetrachloride (covalent compound: the first element is named, followed by the prefix showing the number of atoms (of chlorine) the element bonded to it then the name of that element ending in '-ide')

c) SF_6 : Sulphur hexafluoride (as in 2) above)

In the task 2:

- Put your students in groups of 3-4
- Give your students time between 5 and 10 minutes to read and analyze the content (about the rules of naming complex ions) you have prepared for them or in the student's book S6
- Call two or 3 (or more depending on your time) groups to present their findings.

During the presentation, remember to take notes on some key points (correct ones and wrong ones) that are going to guide you in the next step

- Ask members of other groups to give their comments/ inputs if any.
- Based on learners' production, through questioning, guide them to draw important conclusions. Here, you need to emphasize on the rules governing the nomenclature of ligands and the coordination core especially when it carries a negative charge
- The following are the expected answers

a) $[\text{CuCl}_4]^{2-}$:Tetrachlorocuprate (II) ion (the ligand is named first (with a prefix showing the number of ligands), then the central metal ion ending in '-ate' due to the negative charge on the coordination core)

b) $[\text{Cu}(\text{H}_2\text{O})_6]^{2+}$: Hexaaquacopper (II) ion (the ligand is named first (with a prefix showing the number of ligands), then the central metal ion)

c) $[\text{Cr}(\text{NH}_3)_3(\text{H}_2\text{O})_3]\text{Cl}_3$: Triamminetriaquachromium (III) chloride

d) $[\text{Pt}(\text{NH}_3)_2\text{Cl}_2]$: Diamminedichloroplatinum (II)

e) $(\text{NH}_4)_2[\text{Ni}(\text{C}_2\text{O}_4)_2(\text{H}_2\text{O})_2]$: Ammonium diaquadioxalatonickelate (II)

- Give them checking up 1.5 (a), in student's book as evaluation

Answers to Checking Up 1.4 (a), student's book S6

1.

Element	Name in an anionic complex
Ti	Titanate
V	Vanadate
Cr	Chromate
Mn	Manganate
Co	Cobaltate
Zn	Zincate
Hg	Mercurate
B	Borate
Al	Aluminate
Ge	Germanate

2. Give the systematic names for the following complex ions/compounds:

- $[\text{Cr}(\text{NH}_3)_3(\text{H}_2\text{O})_3]^{3+}$: Triamminetriaquachromium (III) ion
- $[\text{Co}(\text{H}_2\text{NCH}_2\text{CH}_2\text{NH}_2)_3]_2(\text{SO}_4)_3$: Tris-ethylenediamminecobalt (III) sulphate
- $\text{K}_4[\text{Fe}(\text{CN})_6]$: Potassium hexacyanoferrate (II) or potassium ferrocyanide
- $\text{Fe}(\text{CO})_5$: Pentacarbonyliron (0)

Activity 1.4 (b), student's book S6:

1. In the first task, in activity 1.4 (b), student's book S6,

- Guide students to answer the questions in by asking them randomly.
 - The following are the expected answers
- a. Isomerism is referred to as the existence of compounds with the same molecular formula but different structural formulae or different arrangement of atoms in space.
 - b. Yes, isomers are molecules that exist due to isomerism
 - c. Give examples of molecules that can exist as isomers and explain their isomerism:
Cyclopropane and propene are isomers with the molecular formula of C_3H_6 ,
n-butane and methylpropane are isomers formula of C_4H_{10} , ...

2. In the next tasks 2 and 3:

- Give your students time between 10 and 15 minutes to read and analyze the content (about isomerism in complex ions) you have prepared for them or in the student's book,
- Call two or 3 (or more depending on your time) groups to present their findings.

During the presentation, remember to take notes on some key points (correct ones and wrong ones) that are going to guide you in the next step

- Ask members of other groups to give their comments/ inputs if any.
- Based on learners' production, through questioning, guide them to draw important conclusions. Here, you need to emphasize on optical isomers, linkage isomers and coordination isomers by providing more examples.
- The following are the expected answers
- If possible you can end up with checking up 1.4 (b) or give it to them as a homework

Answers to Checking up 1.4 (b), page ..., student's book

1.

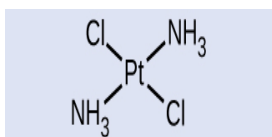

Name: Trans-diamminedichloroplatinum (II)

2.

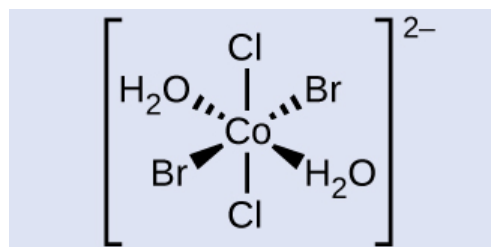

3.

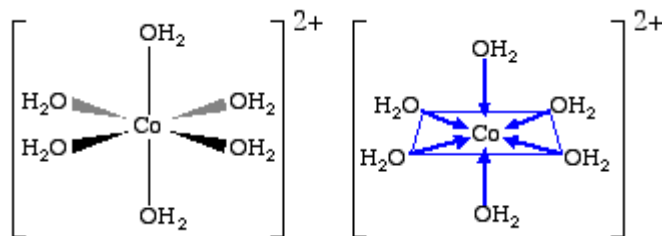

a) Hexaaquacobalt(III) ion

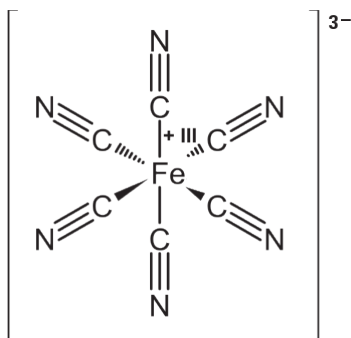

b) Hexacyanoiron (III) ion



c) Diamminesilver (I) ion

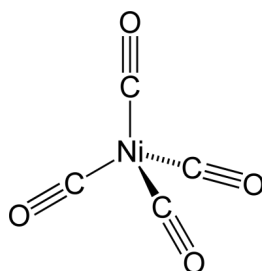

d) The complex compound tetracarbonylnickel

4. i. Tetrahedral structure. This structure can have cis-trans isomers, while tetrahedral structure could not.

ii.

Cis-trans isomerism in $[\text{NiCl}_2(\text{NH}_3)_2]$



5.

a) +4

b) **A** is $[\text{Pt}(\text{NH}_3)_6]^{4+}(\text{Cl})_4^-$; **B** is $[\text{Pt}(\text{NH}_3)_5\text{Cl}]^{3+}(\text{Cl})_3^-$; **C** is $[\text{Pt}(\text{NH}_3)_4\text{Cl}_2]^{2+}(\text{Cl})_2^-$; **D** is $[\text{Pt}(\text{NH}_3)_3\text{Cl}_3]^+\text{Cl}^-$; **E** is $[\text{Pt}(\text{NH}_3)_2\text{Cl}_4]$

c) A=

B=

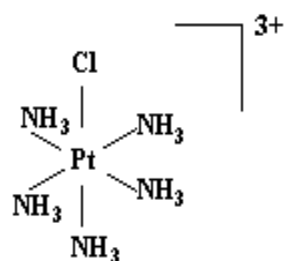
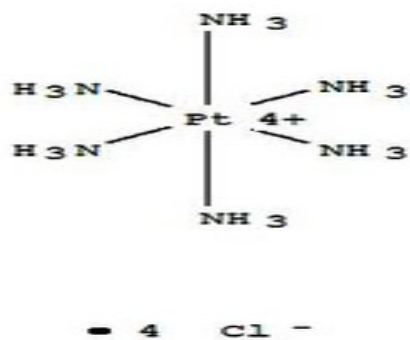

C=

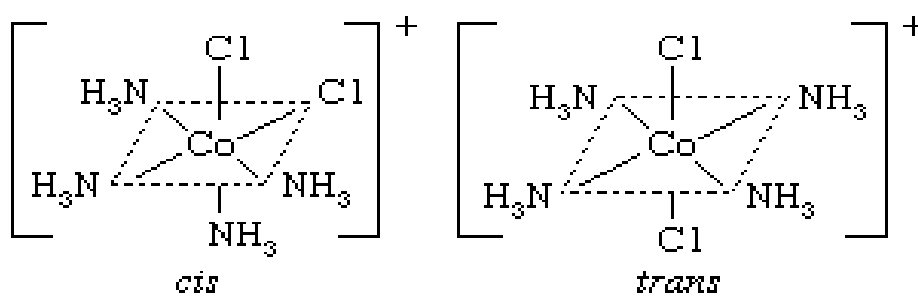

D=

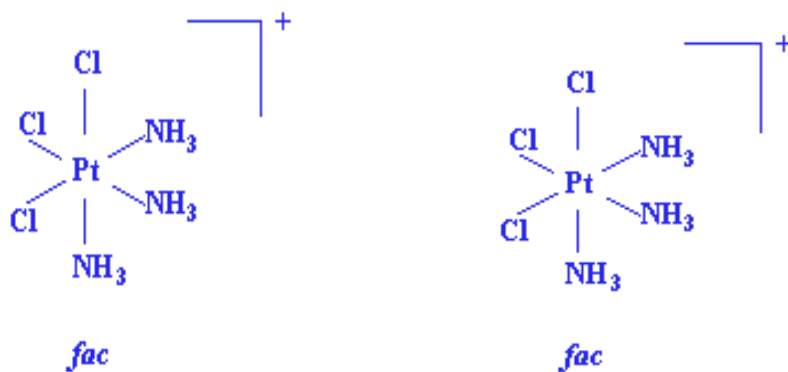

d) C and D

Lesson 5: The chemistry of individual metals

a. Prerequisites/Revision/Introduction:

Students will learn better the chemistry of these elements if they have knowledge on chemistry of the main group metals in the periodic table (covered in senior four)

b. Teaching resources

Use worksheets or books; projectors and/or chalkboard

Materials such as transition metal ribbons; beakers, test tubes, test tube holders, spatula, bunsen burners, pair of tongs, match box,...

Chemicals such as HCl, H₂SO₄, HNO₃, H₂O...

b. Learning activities

You can start by asking your students questions about the physical properties of metals in general as revision. This lesson contains about nine activities, some of which are practicals. Some of the materials to be used can be brought by students by themselves to increase their participation.

Methodological steps:

As a facilitator, you are expected to guide learners to learn by doing activities from 1.5, as described below:

Activity 1.5

- Group your students in pairs (or groups of 3 or more depending on the size of your classroom) and provide them with resources to be used while carrying out their research.
- Give them time for research (20-25 minutes) for discussion in their respective groups
- Call two or 3 (or more depending on your time) groups to present their findings. During the presentation, remember to take notes on some key points (correct ones and wrong ones) that are going to guide you in the next step
- Ask members of other groups to give their comments/ inputs if any.
- Based on learners' production, through questioning, guide them to draw important conclusions. Here, you need to emphasize on the passivity of most transition metals towards some reactants such as air, HNO₃.

Answers to activity 1.5

1. Reactions

Scandium Reactions	
(i) With oxygen	$4 \text{Sc(s)} + 3 \text{O}_2(\text{g}) \longrightarrow 2 \text{Sc}_2\text{O}_3(\text{s})$
(ii) With water	$2 \text{Sc(s)} + 6 \text{H}_2\text{O(l)} \longrightarrow 2 \text{Sc(OH)}_3(\text{aq}) + 3 \text{H}_2(\text{g})$
(iii) With HCl	$2 \text{Sc(s)} + 6 \text{HCl(aq)} \longrightarrow 2 \text{ScCl}_3(\text{aq}) + 3 \text{H}_2(\text{g})$
(v) With Cl_2	$2 \text{Sc(s)} + 3 \text{Cl}_2(\text{g}) \longrightarrow 2 \text{ScCl}_3(\text{s})$
Titanium Reactions	
(i) With oxygen	$4 \text{Ti(s)} + 3 \text{O}_2(\text{g}) \longrightarrow 2 \text{Ti}_2\text{O}_3(\text{s})$
(ii) With water	$2 \text{Ti(s)} + 6 \text{H}_2\text{O(l)} \longrightarrow 2 \text{Ti(OH)}_3(\text{aq}) + 3 \text{H}_2(\text{g})$
(iii) With HCl	$2 \text{Ti(s)} + 12 \text{HCl(aq)} \xrightarrow{\Delta} 2 \text{H}_3\text{Ti[Cl}_6\text{]}(\text{aq}) + 3 \text{H}_2(\text{g})$
(v) With Cl_2	$\text{Ti(s)} + 2 \text{Cl}_2(\text{g}) \xrightarrow{\Delta} \text{TiCl}_4(\text{s})$
2. Properties & Uses (See the Student's Book on individual chemistry of elements)	

Checking up 1.5

Answers to Checking up 1.5

1) a) $2 \text{Cu(s)} + \text{O}_2(\text{g}) \rightarrow 2 \text{CuO(s)}$ [Black]

$\text{CuO(s)} + \text{H}_2\text{SO}_4 \rightarrow \text{CuSO}_4(\text{aq}) + \text{H}_2\text{O(l)}$

Observations

Copper metal reacts with colourless concentrated sulphuric acid solution to form blue aqueous copper (II) sulphate, sulphur dioxide gas and water.

$\text{Cu(s)} + \text{H}_2\text{SO}_4(\text{aq}) \rightarrow \text{Cu}^{2+}(\text{aq}) + \text{SO}_4^{2-}(\text{aq}) + \text{SO}_2(\text{g}) + \text{H}_2\text{O(g)}$

b) Chromium dissolves rapidly in hot concentrated aqueous alkali forming a blue solution containing chromium (II) ion and hydrogen gas is evolved.

$\text{Cr(s)} + 2 \text{OH}^-(\text{aq}) + 2 \text{H}_2\text{O(l)} \rightarrow [\text{Cr(OH)}_4]^{2-}(\text{aq}) + \text{H}_2(\text{g})$

c) Nickel (II) ions complexes with water under acidic and neutral conditions forming a light green hexaqua nickel ion. Ni^{2+}

$(\text{aq}) + 2\text{OH}^-(\text{aq}) \rightarrow \text{Ni(OH)}_2(\text{s})$

This precipitation reaction can be written as:





$[\text{Ni(H}_2\text{O)}_6]^{2+}(\text{aq}) + 2\text{OH}^-(\text{aq}) \rightarrow [\text{Ni(OH)}_2(\text{H}_2\text{O)}_4] + 2\text{H}_2\text{O(l)}$

d) In hot aqueous alkali, powdered zinc dissolves with effervescence :

$\text{Zn(s)} + 2 \text{OH}^-(\text{aq}) + \text{H}_2\text{O(l)} \rightarrow [\text{Zn(OH)}_4]^{2-}(\text{s}) + \text{H}_2(\text{g})$

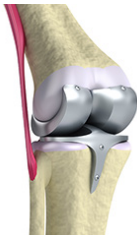
2) Properties

- a) Scandium has almost as low a density as aluminium and a much higher melting point.
- b) The alloys of Titanium are mainly used in aircraft, spacecraft and missiles because of their low density and ability to withstand extremes of temperature.
- c) Vanadium-steel alloys are very tough.
- d) The waste effluent from using chrome is toxic.
- e) Manganese steel (containing about 13% manganese) is extremely strong.
- f) Iron is an enigma! It rusts easily, yet it is the most important of all metals. 90% of all metal that is refined today is iron where it is mostly used to manufacture steel (used in civil engineering and in manufacturing).
- g) This is because Cobalt is an essential trace element and found at the centre of the vitamin B₁₂ (cobalamine, C₆₃H₈₈CoN₁₄O₁₄P).
- h) Nickel resists corrosion, even when red hot.
- i) Copper conducts both heat and electricity very well, and can be drawn into wires.
- j) Zinc has the property to prevent corrosion.

	Object	Transition metal	Properties	Other uses
1		Scandium	See the Student's Book	See the Student's Book
2		Titanium		
3		Vanadium		
4		Chromium		
5		Manganese		

6		Iron		
7		Cobalt		
8		Nickel		
9		Copper		
		Zinc		

Lesson 6: Identification of ions transition metals

a. Prerequisites/Revision/Introduction:

Students will learn better the identification of ions if they have knowledge on oxidation-reduction reactions of the main group metals in the periodic table (covered in senior four)

b. Teaching resources

Use worksheets or books; projectors and/or chalkboard

Materials: beakers, test tubes, test tube holders, spatula, bunsen burners, droppers, etc. **Chemicals** such as aqueous solutions containing transition metal salts, aqueous solutions of NaOH, NH₃, HCl, H₂SO₄, HNO₃...

c. Learning activities

You can start by asking your students questions about the physical properties of metals in general as revision. This lesson contains about nine activities, some of which are practicals. Some of the materials to be used can be brought by students by themselves to increase their participation.

Methodological steps:

As a facilitator, you are expected to guide learners to learn by doing activities from 1.6, as described below:

Answers to activity 1.6, in student's book S6

Before the practical (preparation)

- Try to copy this activity on a sheet and make copies equal to the number of groups (of 4 to 5) that you will form according to your class.
- Make sure you understand well the content (theory) about the practical to be performed so as to help students link it with their observations.
- Try to make the required materials available before your students in the laboratory.

In the practicals

- Start by telling your student to join laboratory tables/benches, forming groups of 4 to 5
- Give them worksheets and ask them to read instructions first.
- Give them time for manipulation (10-15 minutes). Here, they have to follow the instructions provided on worksheets. They have to record their observations making a report to be presented.

- Call two or 3 (or more depending on your time) groups to present their findings. During the presentation, remember to take notes on some key points (correct ones and wrong ones) that are going to guide you in the next step
- Ask members of other groups to give their comments/ inputs if any.
- Based on learners' production, through questioning, guide them to draw important conclusions.

Activity 1.7 : Identification of ions in Y

Tests	Observations	Deductions
a) Note appearance of Y	Green solid/green powder	Fe ²⁺ , Cr ³⁺ , Cu ²⁺ or Ni ²⁺ ions are suspected
b) To one spatula of Y in a test tube add a few drops of diluted nitric acid or diluted sulphuric acid	Effervescence is observed. Colourless gas which evolves turns blue litmus paper red and turns lime water milky.	The gas is CO ₂ Presence of CO ₃ ²⁻
c) Heat one spatula end-full of Y in a dry test tube until there is no further change	Colourless gas which evolves turns blue litmus paper red. Green solid give a black solid residue	The gas is CO ₂ CO ₃ ²⁻ ions are confirmed. Black solid may be CuO
d) Put one spatula of Y in a test tube and add about 6cm ³ of water and shake. Divide the solution into three portions.	Y dissolves to give a blue solution.	Cu ²⁺ ions are suspected
(i) To the first solution add diluted NaOH drop wise until in excess	A pale blue precipitate formed, insoluble in excess	Cu ²⁺ ions are present
(ii) To the 2 nd portion, add ammonia solution drop wise until in excess	A blue precipitate formed, soluble in excess to form a deep blue solution	Cu ²⁺ ions are confirmed

The cation in Y is Cu^{2+}

The anion in Y is CO_3^{2-}

Ionic equation for the reaction in test (i) is:

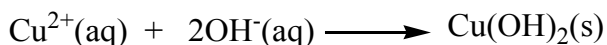

Ionic equations for the reactions in test (ii) are:

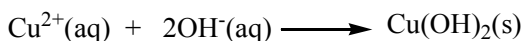

Answers to Checking up 1.6 (a)

Tests	Observations	Deductions
a) Note appearance of K	Blue/green	Fe^{2+} , Cr^{3+} , Cu^{2+} or Ni^{2+} ions are suspected
b) Put one spatula end-full of K in a dry test tube and heat it strongly.	Colourless vapour condenses to give a colourless liquid which turns anhydrous copper sulphate blue and also turns litmus red and forms white fumes with conc. ammonia. Green solid gives a black solid residue.	Hydrated salt. Gas is hydrogen chloride and Cl^{-} is most likely present. Black solid is CuO , FeO or MnO_2
c) To a spatula end-full of K in a test tube add a few drops of concentrated sulphuric acid then heat the mixture.	Effervescence, a colourless gas, turns litmus red and forms white fumes with conc. Ammonia.	Hydrogen chloride gas. Cl^{-} is most likely present.
d) Dissolve about one spatula end-full of K in about 5 cm ³ of water and divide the solution into four portions.	K dissolves to give a green solution.	Fe^{2+} , Cr^{3+} , Cu^{2+} or Ni^{2+} ions are suspected
(i) To the 1 st portion add dilute sodium hydroxide solution dropwise until in excess and heat the mixture.	A pale blue precipitate insoluble in excess. On heating the blue precipitate forms a black solid	Cu^{2+} ions are suspected Black solid is CuO

(ii) To the 2 nd portion, add ammonia solution drop wise until in excess	A blue precipitate formed, soluble in excess to form a deep blue solution	Cu ²⁺ ions are present
(iii) To the 3 rd portion add a few drops (2 or 3 drops) of potassium hexacyanoferrate (II) solution	A red-brown precipitate formed	Cu ²⁺ ions are confirmed
(iv) To the 4 th portion add a few drops of lead (II) nitrate solution and warm the mixture.	White precipitate which dissolves on heating and reappears on cooling	Cl ⁻ ions are confirmed

- The cation present in the compound K is **Cu²⁺**
- The anion present in the compound K is **Cl⁻**

Answers to Checking up 1.6 (b)

You are provided with substance D which contains one cation and one anion. You are required to identify the cation and anion in D. Carry out the following tests and record your observations and deductions in the table below. Identify any gas evolves.

Tests	Observations	Deductions
1) Note appearance of D	Green solid	Fe ²⁺ , Cr ³⁺ , Cu ²⁺ or Ni ²⁺ ions are suspected
2) Put one spatula end-full of D in a test tube and heat it strongly until there is no further change	- Colourless vapour which condenses on the cooler part of the test tube. - A colourless pungent gas which turns potassium dichromate green is formed. - The residue is a dark green solid.	- hydrated salt present. - Gas is SO ₂ probably SO ₃ ²⁻ or SO ₄ ²⁻ salt present. - D is a transition compound probably containing Cr ³⁺ or Ni ²⁺
3) Dissolve one spatula of D in about 10cm ³ of water and divide the resultant solution into five parts.	D dissolves to give green solution.	Probably D contains Cr ³⁺ , Ni ²⁺ , Fe ²⁺ or Cu ²⁺ .
a) To the 1 st part is added sodium hydroxide solution drop wise until in excess	A green precipitate which slightly dissolves to give a violet solution.	Probably Cr ³⁺ present

b) To the second part is added dilute sodium hydroxide solution dropwise until in excess followed by 1cm ³ of 10% hydrogen peroxide solution and the resultant mixture boiled and later cooled. the resultant solution is then divided into three portions	A green precipitate soluble in excess NaOH to form a green solution. On boiling with H ₂ O ₂ a yellow solution is formed with evolution of a colourless gas which relights a glowing splint.	Cr ³⁺ presence confirmed. H ₂ O ₂ oxidises Cr ³⁺ in an alkaline medium to yellow chromate. The gas is oxygen.
i) To the 1 st portion is added silver nitrate solution dropwise until no further change takes place.	A brick red precipitate.	Silver chromate is formed. Hence CrO ₄ ²⁻ compound formed.
ii) To the second portion is added a drop of barium chloride solution	A pale yellow precipitate.	Barium chromate formed. Hence CrO ₄ ²⁻ compound formed
iii) To the 3 rd portion is added a few drops of hydrochloric acid.	The yellow solution turns orange	A dichromate has been formed from a chromate
c) To the third part of the solution is added a few drops of butanol followed by 3 drops of dilute H ₂ SO ₄	A deep blue lake is formed	Presence of Cr ³⁺
d) To the fourth part was added a few drops of lead nitrate solution.	A white precipitate is formed	Probably Cl ⁻ , CO ₃ ²⁻ or SO ₄ ²⁻ present
e) To the last part was carried a test of one's own choice. <u>Test:</u> To the last portion is added a few drops of barium nitrate followed by 1 cm ³ of dilute nitric acid.	A white precipitate insoluble in nitric acid is formed	Presence of SO ₄ ²⁻ confirmed.
<p>- The cation in D is Cr³⁺</p> <p>- The anion in D is SO₄²⁻</p>		

Answers to Checking up 1.6 (c)

Aqueous sodium hydroxide is added separately to solutions of salts of the transition metals **A**, **B** and **C**. Identify **A**, **B** and **C** from the following observations.

A: The white precipitate which appears is soluble in an excess of aqueous sodium hydroxide and also in aqueous ammonia. **Answer: Zn (zinc)**

B: The blue precipitate which appears is insoluble in an excess of aqueous sodium hydroxide but dissolves in aqueous ammonia to form a deep blue solution. **Answer: Cu (copper)**

C: The green precipitate which appears is insoluble in an excess of aqueous sodium hydroxide and also in aqueous ammonia. **Answer: Fe (iron)**

1.6. Summary of the unit

Transition metals elements are the elements that form ions with partially filled *d*-orbitals. They are also called *d*-block elements because their electrons end in *d*-orbitals.

The properties of transition elements are between the highly reactive metallic elements of the *s*-block elements which generally form ionic compounds and the less reactive elements of the *p*-block which form covalent compounds. Transition elements form ionic compounds as well as covalent compounds.

These metals are all hard and dense, good conductors of heat and electricity. One exception, Mercury, is liquid at room temperature. They do not show added gradation in physical properties across the period as it is in *s* block metals. They are remarkably similar to one another in their properties in general. The reason for the similarity of the first transition series from left to right, while each additional electron is entering the 3*d* shell, the chemistry of the elements continues to be determined largely by the 4*s* electrons.

However, they have their characteristics that differentiate them from main group elements such as the following:

- They have variable oxidation states
- They have high ability of being catalysts
- Many of their compounds are paramagnetic
- They form alloys
- They form complex ions
- Many of their ions and compounds are coloured

All these characteristics are due to their electronic configuration which has a partially filled 3*d*-orbital.

Zinc and Scandium show abnormal properties compared to the other members of the series because the 3*d*-orbitals of their ions/compounds are completely filled or empty respectively.

Complex compounds/ions are named by following a set of rules. The ligands are named first in alphabetical order then the central metal ion/atom.

Complex ions/compounds also show isomerism (both structural isomerism and stereoisomerism).

The chemical reactions (with air, water, acids ...) and uses of each member of this series were discussed. Hopefully, you noticed how important these metals and their compounds are in our daily life.

There are tests to identify transition metal cations and some have been presented.

1.7. Additional information for teachers

Isomers are different chemical species that have the same chemical formula. Isomerism among transition metal ion complexes arises as a result of different arrangements of their constituent atoms. The categories of isomerism exhibited by coordination compounds are of two main types (stereoisomerism and structural isomerisms) as seen in the Student Book. As the stereoisomerism has been discussed in the Student Book, let us now discuss about the **structural isomerism**.

There are several types of structural isomerism frequently encountered in coordination chemistry and the following represents some of them.

1. Ionization isomers

Ionization isomers occur when one anionic ligand in the inner coordination sphere is replaced with the counter ion from the outer coordination sphere. This arises when two isomers differ in the distribution of ions between those which are directly bonded and those not directly. A simple example of two ionization isomers are $[\text{CoCl}_6][\text{Br}]$ and $[\text{CoCl}_5\text{Br}][\text{Cl}]$.

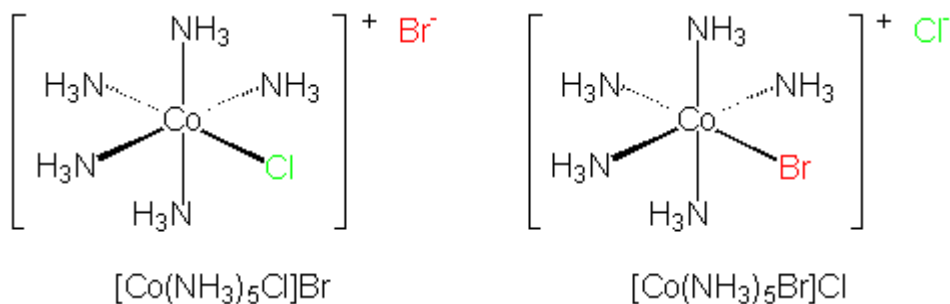

2. Coordination Isomerism

Coordination isomerism occurs when compounds containing complex anionic and cationic parts can be thought of as occurring by interchange of some ligands from the cationic part to the anionic part. Hence, there are two complex compounds

bound together, one with a negative charge and the other with a positive charge. In **coordination isomers**, the anion and cation complexes of a coordination compound exchange one or more ligands. For example, the $[\text{Co}(\text{NH}_3)_6][\text{Cr}(\text{C}_2\text{O}_4)_3]$ compounds and $[\text{Co}(\text{C}_2\text{O}_4)_3][\text{Cr}(\text{NH}_3)_6]$ compound are coordination isomers. Other examples:

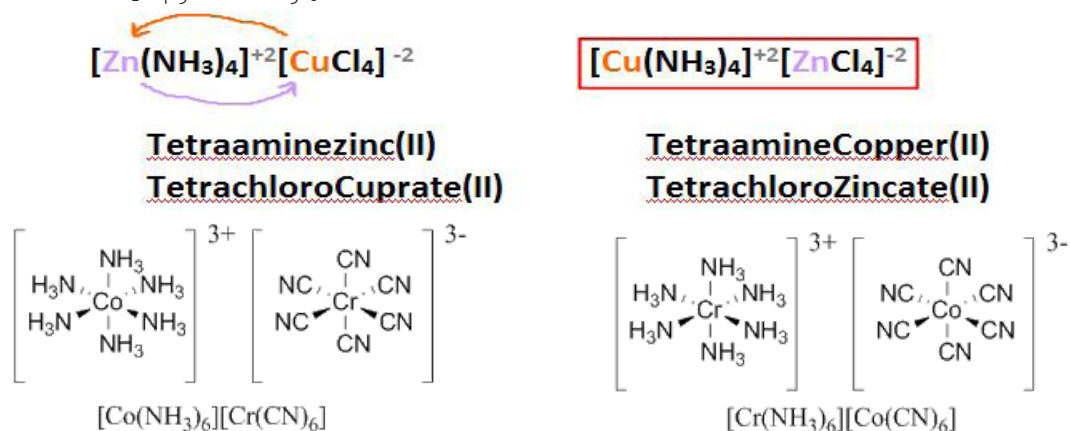

3. Linkage Isomers

Linkage isomers occur when the coordination compound contains a ligand that can bind to the transition metal center through two different atoms. For example, the CN ligand can bind through the carbon atom (cyano) or through the nitrogen atom (isocyano). Similarly, SCN^- can be bound through the sulfur or nitrogen atom, affording two distinct compounds ($[\text{Co}(\text{NH}_3)_5\text{SCN}]^{2+}$ or $[\text{Co}(\text{NH}_3)_5\text{NCS}]^{2+}$).

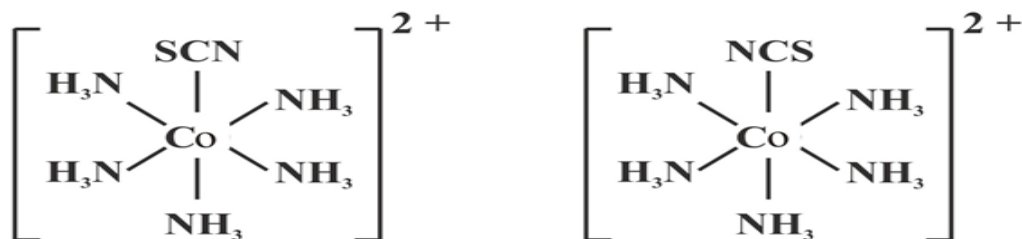

Other examples:

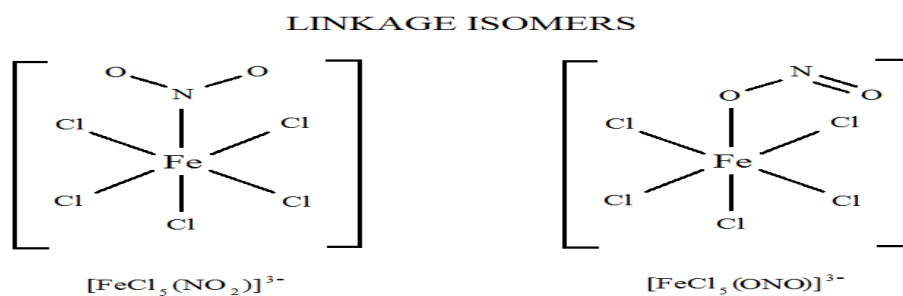

$[\text{Co}(\text{ONO})(\text{NH}_3)_5]\text{Cl}$ (the nitrito isomer -O attached) and $[\text{Co}(\text{NO}_2)(\text{NH}_3)_5]\text{Cl}$ (the nitro isomer - N attached).

4. Hydration Isomers

This is a type of isomerism that results from replacement of a coordinated group by a solvent molecule (Solvate Isomerism), which in the case of water is called Hydration Isomerism. The best known example of this occurs for chromium chloride ($\text{CrCl}_3 \cdot 6\text{H}_2\text{O}$) which may contain 4, 5, or 6 coordinated water molecules (*assuming a coordination number of 6*).

$[\text{CrCl}_2(\text{H}_2\text{O})_4]\text{Cl} \cdot 2\text{H}_2\text{O}$ (bright-green), $[\text{CrCl}(\text{H}_2\text{O})_5]\text{Cl}_2 \cdot \text{H}_2\text{O}$ (grey-green) and $[\text{Cr}(\text{H}_2\text{O})_6]\text{Cl}_3$ (violet colored).

These isomers have very different chemical properties and on reaction with AgNO_3 to test for Cl^- ions, would find 1, 2, and 3 Cl^- ions in solution, respectively.

Upon crystallization from water, many compounds incorporate water molecules in their crystalline frameworks. These “waters of crystallization” refer to water that is found in the crystalline framework of a metal complex or a salt, which is not directly bonded to the metal cation.

In the first two hydrate isomers, there are water molecules that are artifacts of the crystallization and occur inside crystals. This water of crystallization is the total weight of water in a substance at a given temperature and is mostly present in a definite (stoichiometric) ratio.

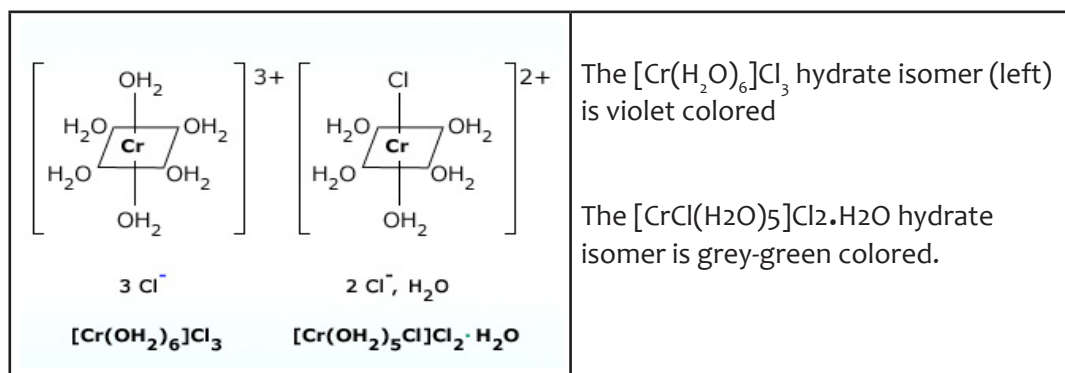

1.8. End unit assessment

Learning and assessment standards:

Investigate the properties of transition metals and relate them to their electronic structure, developing and presenting explanations and conclusions using language precisely.

ANSWERS TO END UNIT 1 ASSESSMENT QUESTIONS

(A) MULTIPLE CHOICE QUESTIONS

- (1) (iv) Magnesium
(2) (i) $\text{Ag}(\text{NH}_3)_2^+$
(3) (i) Cu^+
(4) (iii) $[\text{Cu}(\text{H}_2\text{O})_6]^{2+} + \text{EDTA}^{4-} \rightarrow [\text{CuEDTA}]^{2-} + 6\text{H}_2\text{O}$
(5) (iii) $[\text{Ni}(\text{NH}_2\text{CH}_2\text{CH}_2\text{NH}_2)_2\text{Cl}_2]$
(6) (iv) Are diamagnetic
(7) C
(8) (ii) $[\text{Cu}(\text{OH})_2(\text{H}_2\text{O})_4]$ (+2)
(9) (ii) Chromium

B. OPEN QUESTIONS

(1) Complete the following table:

Coordination Compound	Complex Ion	Ligands	Counter Ion	Coordination Number	Oxidation State of the metal
$[\text{Co}(\text{H}_2\text{O})_6]\text{Cl}_3$	$[\text{Co}(\text{H}_2\text{O})_6]^{3+}$	H_2O	Cl^-	6	+3
$\text{K}_3[\text{Fe}(\text{CN})_6]$	$[\text{Fe}(\text{CN})_6]^{3-}$	CN^-	K^+	6	+3
$[\text{Cu}(\text{NH}_3)_4]\text{SO}_4$	$[\text{Cu}(\text{NH}_3)_4]^{2+}$	NH_3	SO_4^{-2}	4	+2

(2) They have incomplete d-orbitals

(3) 4s

(4) a. Cu, Zn, Fe

b. Because a covalent bond is formed by a sharing of electrons between a transition metal atom/ion and a ligand(s).

(5) Names of the coordination compounds

- Tetraaquacobalt(II) chloride
- Hexaamminechromium(III) nitrate
- Potassium hexacyanoferrate(II)
- Sodium tetracyanoaurate(III)
- Diaquabis(ethylenediamine)cobalt(III) chloride

(6)

(a) (i) coordinate bond is a shared pair of electrons in the bonded pair has been provided by one of the bonding atoms only, also called a dative covalent bond.

(ii) A water molecule has a lone pair to share with a metal cation

(b) Bidentate ligands

Example: Ethylenediamine ($\text{NH}_2\text{CH}_2\text{CH}_2\text{NH}_2$)

(7)

(a) EDTA^{4-} is a polydentate/hexadentate ligand

(b) Number of moles of $\text{EDTA}^{4-} = 0.0168 \times 36.2 \times 10^{-3} = 0.60816 \times 10^{-3}$ moles

Because the mole ratio between $[\text{Co}(\text{H}_2\text{O})_6]^{2+}$ and EDTA^{4-} is 1:1

Therefore the molar concentration of $\text{CoCl}_2 = \frac{0.60816 \times 10^{-3}}{25 \times 10^{-3}} = 0.024 \text{ M}$

(8) a.

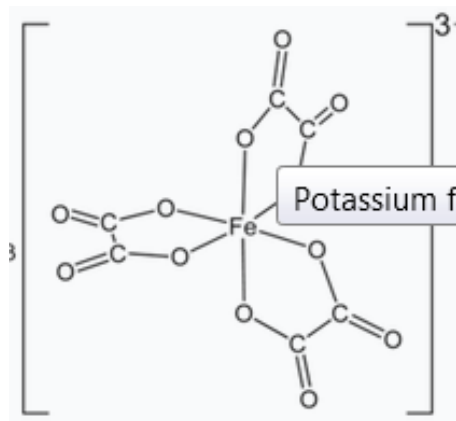

b. Haemoglobin

c. Transport of oxygen in blood

(9)

a. Because each of them has a pair of electrons to donate to a transition metal ion

b. +3 and 5 respectively

(10) (a) Because they have different ligands

- (b) Tollen's reagent: $[\text{Ag}(\text{NH}_3)_2]^+$
(11) Cl-has higher size than F-

1.9. Additional Activities

Remedial Questions

1. Write down the name of the following complexes:

- (a) $[\text{Co}(\text{NH}_3)_4\text{Cl}_2]^+$
(b) $(\text{NH}_4)_3[\text{Cr}(\text{NCS})_6]$
(c) $\text{Ni}(\text{CO})_4$
(d) $\text{K}_4[\text{Fe}(\text{CN})_6]$
(e) $[\text{Cr}(\text{en})_3]\text{Cl}_3$

2. Write down the formula of the following:

- (a) Tetrachloronickelate(II)
(b) Pentaamminenitrocobalt(III) ion
(c) Potassium hexacyanoferrate(III)
(d) Dichlorobis(ethylenediamine) chromium(III) ion

3. Transition metals form complex ions. Using actual examples of complex ions formed by transition metal ions, give the formula of

- A linear complex ion,
A tetrahedral complex ion and
An octahedral complex ion formed by using a bidentate ligand.

Answers:

1. (i) Tetraamminedichlorocobalt (III) ion
(ii) Ammonium-hexaisothiocyanatochromate (III)
(iii) Tetracarbonylnickel (0)
(iv) Potassium-hexacyanoferrate (II)
(v) Tris(ethylenediamine) chromium (III) chloride
2. (i) $[\text{NiCl}_4]^{2-}$
(ii) $[\text{Co}(\text{NH}_3)_5\text{NO}_2]^{2+}$
(iii) $\text{K}_3[\text{Fe}(\text{CN})_6]^-$
(iv) $[\text{Cr}(\text{en})_2\text{Cl}_2]^+$
- 3.

(a) Linear complex	e.g.	$[\text{Ag}(\text{NH}_3)_2]^+$
(b) Tetrahedral complex	e.g.	$[\text{CoCl}_4]^{2-}$
(c) Octahedral complex	e.g.	$[\text{Fe}(\text{H}_2\text{NCH}_2\text{CH}_2\text{NH}_2)_3]^{3+}$

Consolidation questions

- (i) What is meant by the term *co-ordinate bond*?
- (ii) Explain why co-ordinate bonds can be formed between transition metal ions and water molecules.
- (iii) What name is given to any ligand that can form two co-ordinate bonds to one metal ion? Give an example of such a ligand.
1. Titanium (IV) chloride reacts with propanone to form a complex compound in which two molecules of propanone have combined with one molecule of titanium (IV) chloride. Draw a possible structure for the complex formed, indicating clearly which atoms are bonded to titanium.
- (a) What is a transition element?
- (b) Give, by name or formula, a transition metal complex which
- Occurs in the body
 - Is used as an anti-cancer drug
- (c) Suggest one feature of silver chemistry which is characteristic of the transition elements.
- (d) Suggest one feature of silver chemistry which is not characteristic of the transition elements.
2. When titanium dissolves in concentrated hydrochloric acid, the violet $[\text{Ti}(\text{H}_2\text{O})_4\text{Cl}_2]^+$ ion is formed. Deduce the oxidation state and co-ordination number of titanium in this ion. Draw the structures of the two isomers of $[\text{Ti}(\text{H}_2\text{O})_4\text{Cl}_2]^+$.

Answers

1. (i) Shared or pair of electrons Come from one atom
(ii) TM ions can accept electron pairs H_2O (O) can donate pair
(iii) Bidentate. For example, $\text{NH}_2\text{CH}_2\text{CH}_2\text{NH}_2$ or $\text{C}_2\text{O}_4^{2-}$
- 2.

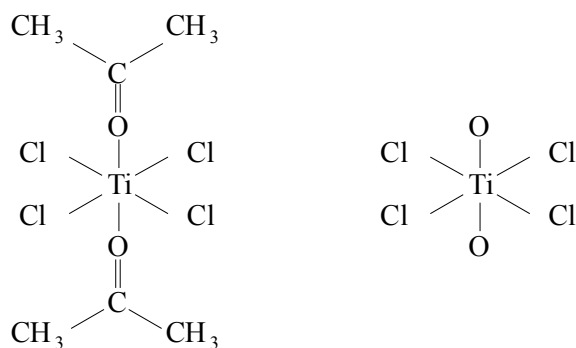

You can draw the cis isomer irrespective of what is bonded to O

3. (a) Partially filled d shell
 - (b) (i) haemoglobin or heme
 - (ii) cis-platin or $\text{Pt}(\text{NH}_3)_2\text{Cl}_2$
 - (c) Complexes or catalysis
 - (d) Colourless/white compounds or one common oxidation state

4. a. Oxidation state: +3 and coordination number: 6

b.

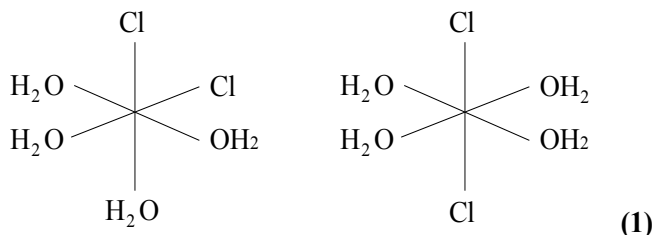

Extended Questions

1. a. Complete the electronic configuration of a cobalt (II) ion
 $\text{Co}^{2+} [\text{Ar}]$
- b. When cobalt (II) chloride is treated, under certain conditions, with the bidentate ligand,
 $\text{NH}_2\text{CH}_2\text{CH}_2\text{NH}_2$, (which can be represented by the symbol “en”), the compound $[\text{CoCl}_2(\text{en})_2]\text{Cl}$ is formed.
 - i. What is the oxidation state of cobalt in the compound formed?
 - ii. What is meant by the term bidentate as applied to a ligand?

- iii. What is the co-ordination number of cobalt in this compound?
- c) When this compound is treated with aqueous silver nitrate, only one mole of silver chloride is produced per mole of compound. Explain this observation.
2. a. When hydrazine, NH_2NH_2 , reacts with cobalt (II) chloride in aqueous solution, the compound $\text{CoCl}_2(\text{NH}_2\text{NH}_2)_2$ is formed. This compound has a polymeric structure in which cobalt is six co-ordinate and the cobalt ions are linked by hydrazine molecules. Draw the structure of the repeating unit of the polymer.
- b. State three factors which cause a colour change in reactions of transition metal complexes.
3. Draw structures for each of the following species.
- (a) $[\text{Ni}(\text{CN})_5]^{3-}$ which is trigonal bipyramidal.
- (b) $\text{Nb}_2\text{Cl}_{10}$ in which niobium is six co-ordinate and in which some chlorine atoms are bonded to both niobium atoms.
- (c) $[\text{Fe}(\text{C}_2\text{O}_4)_3]^{3-}$ in which the ethanedioate ions are bidentate.
- (d) $[\text{cis-PtCl}_2(\text{NH}_3)_2]$ which is square-planar.

Answers

1. a. $\text{Co}^{2+} [\text{Ar}] 3d^7$
- b. i. 3
- ii. Two donor atoms or 2 lone pairs bond
- iii. 6
- 1 Cl- available or ionic structure/ 2 Cl are covalently bonded or strongly bonded or complex ion stable
2. a

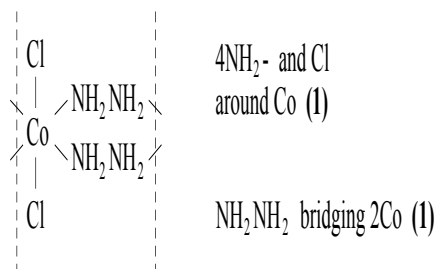

or 1 bridging and 1 chelating NH_2NH_2 , octahedral 90°

- b. Ligand change
- Oxidation state change
- Co-ordination number change

3.

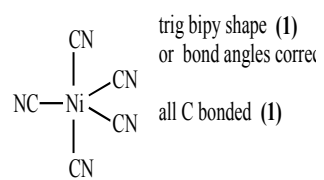

(a)

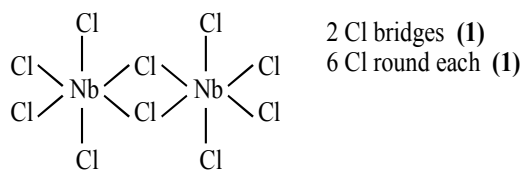

(b)

UNIT₂: EXTRACTION OF METALS

2

2.1. Key unit competence

To be able to relate the properties of metals to their methods of extraction and uses and suggest

preventive measures to dangers associated with their extraction.

2.2. Prerequisite knowledge and skills

Students will learn better extraction of metals if they have understanding on: The chemistry and uses of sodium (Senior 4, unit 6), of aluminium (Senior 4, unit 8); redox-reactions and reactivity series (Senior 4, unit 17), electrolysis (Senior 5, unit 13) and individual chemistry and uses of transition metals (Senior 6, unit 1).

2.3. Cross-cutting issues to be addressed

Environment and Sustainability

Operations and waste products associated with metal extraction and processing are the principal causes of environmental concerns about metal mining. Concerns include physical disturbances to the landscape, soil and water contamination, air contamination and public safety. Students of Senior 6 who study extraction of metals must be aware of the sustainability of environment to be applied as the finalists of Secondary Studies. The teacher must emphasize on how the problems from metal extractions must be handled and the preventive measures to be taken before and even during the extraction process.

Financial Education

Metals are used daily by most people, so are useful. Extraction of metals is done also by many people as profession. Mining and processing metals give miners work to do, so money is brought into the economy- leading to better quality of life. So, you teacher, you have to be aware that students who are studying the methods of extraction of metals need to know how these works lead to the income.

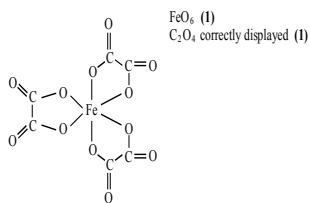

(c)

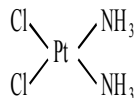

square with N bonded NH₃ (1)
cis Cls (1)

(d)

2.4. Guidance on the introductory activity

Methods of extraction of metals are all based on the properties of the metal. To introduce this unit, remember to recall the reactivity series of metals and how it is applied. The following is a guidance of how you can help your learners enter in the unit with open mindset about the methods of extraction of different metals.

- This activity is worked in the laboratory.
- Put your students in groups of 4-6 (depending on the size of your class).
- Provide them with books or worksheets with the **introductory activity** (you may even use the projector) unit 2 from Student's Book S6.
- Give them time between 15 and 20 minutes to read, analyze, interpret, discuss and answer questions all about the activity.
- Ask 3 groups to present their findings.
- Allow some students to comment about the findings of their colleagues present.
- Take this time to use some questions in order to draw the conclusion (using the answers being provided by student).

Introductory activity

I.

1. Yes

2. Metal : Gold and Mineral: Cassiterite (SnO₂)

3. jewelry, uses of gold in computers, dentistry, ect.

Tin is extracted from cassiterite; and it has many uses such as the prevention of corrosion, tin salts (Sn II) is used as reducing agent.

II. Procedure

- Transfer one spatula measure of copper (II) oxide to a hard-glass test-tube.
- Carefully add one spatula of charcoal powder on top of the copper (II) oxide without any mixing.
- Strongly heat these two layers for 5 minutes in a Bunsen flame.
- Allow the tube to cool and then look closely at where the two powders meet in the test tube.

Questions

1. Describe the solid copper (II) oxide before heating.
2. Name the gas formed in the reaction.
3. Describe the solid remaining after heating.
4. Name the solid formed in the reaction.
5. Write the word and symbol equations for the reactions.
6. What does this reaction tell you about the relative reactivities of carbon and copper?
7. Explain why this reaction is a redox reaction.

Proposed Answers about Introductory activity for unit 2, student's book S6.

I. Consider answers from students.

II. Proposed Answers from the experiment

1. Before heating CuO is normally black.
2. Carbon dioxide
3. Red brown solid on the surface of test tube
4. Copper metal

Word Equation:	Copper (II) oxide + Carbon → Copper + Carbon dioxide
Formula Equation:	$2 \text{CuO (s)} + \text{C (s)} \rightarrow 2 \text{Cu (s)} + \text{CO}_2 \text{(g)}$

1. This shows that carbon is above copper in the reactivity series (carbon is more reactive than copper).
2. This is a redox reaction because both reduction and oxidation occurred in the same reaction.

2.5. List of lessons/sub-heading

#	Lesson title	Learning objectives	Number of periods
1	Introductory Activity Relating properties of metals to their methods of extraction.	Relate the properties of metals to their methods of extraction.	2

2	Methods of extraction of copper,	<ul style="list-style-type: none"> • Appreciate the use of transitional metals. • Appreciate the cost or difficulties related to the extraction of copper, iron, tantalum, zinc, wolfram. • Describe extraction of copper, iron, sodium, tantalum, zinc, wolfram, aluminium and tantalum. • Outline and explain the uses copper, iron, tantalum, zinc, wolfram, tin ore (cassiterite). • Develop orderliness in work to present. • Develop culture of working in groups. 	1
3	Methods of extraction of iron,		1
4	Methods of extraction of tin,		1
5	Methods of extraction of zinc,		1
6	Methods of extraction of sodium		1
7	Methods of extraction of aluminium,		1
8	Methods of extraction of wolfram (tungsten).		1
9	Methods of extraction of tantalum,		1
10	Dangers associated with extraction of metals (e.g. pollution).		Appreciate the dangers associated with extraction of different metals.
11	Preventive measures associated with metal extraction.	Explain the issues associated with the extraction of metals and preventive measures.	1
	ASSESSMENT		2

Lesson 1: Relating properties of metals to their methods of extraction

a. Prerequisites/Revision/Introduction:

Students will learn better how to relate properties of metals to their methods of

extraction if they have knowledge on chemistry and uses of metals (unit 6 and unit 8 in Senior 4), redox reactions and reactivity series of metals (unit 17 in Senior 4), electrolysis (unit 13 in Senior 5) and individual chemistry of transition metals (unit 1 in Senior 6).

b. Teaching resources

You can use worksheets/books, projectors /chalkboard, etc.

c. Learning activities

- Before teaching this topic, be aware that many students know something about the extraction of metals (mining processes, purification or refining, etc). The learning **activity 2.1** is here to help you and your students enter smoothly the extraction of metals.
- As a facilitator, you are expected to guide learners to learn by doing **activity 2.1**, as described below.
- Give the activity to students. This activity has to be done in pairs and it takes at most 15 min.
- Choose randomly three representatives of all groups to present their findings.
- Allow some other students to comment about the findings presented by their colleagues.
- Give your feedback highlighting how the methods of metal extraction depend mainly on the reactivity of the metal and make clear different ways to concentrate the ore.
- Through different small verbal questions, help the students to make the conclusion themselves.
- To check their understanding, give them the **Checking Up 2.1** in the Student's Book as an individual homework. The feedback will be given in the next session after the correction.
- You may refer to the proposed answers of the **Activity 2.1** and the **Checking up 2.1**

Answers to Activity 2.1 in Student's Book

1. Different methods of extraction of metals
 - a. Reduction by carbon (if the metal to extract is less reactive than carbon).
 - b. Electrolysis (if the metal to extract is very reactive)
 - c. Reduction by hydrogen
 - d. Reduction by very reactive metal
2. Ores have to be concentrated before other way of processing because many of them are available in low proportions. Concentrating the ore may be done by physical or chemical means. More details, see the Student's Book.

Answers to Checking up 2.1

1. An ore is any naturally-occurring source of a metal that you can economically extract the metal from.
2. What is the difference between an ore and a mineral? The chemical substances in the earth's crust obtained by mining are called minerals. Minerals, which act as source for metal, are called "Ore".
3. Yes, because they are not renewable
4. No, ores are not renewable, they can be used up.
5. Carbon is used for extraction for the metal below it in the reactivity series.
6. Carbon, iron, copper, zinc
7. Electrolysis is used for extraction when the metal to be extracted is highly reactive (sodium, calcium and even aluminium).
8. Meaning of the terms:
 - Dressing of ore is the Removal of the unwanted impurities from ore.
 - Smelting is the process by which a metal is obtained, either as the element or as a simple compound, from its ore by heating beyond the melting point, ordinarily in the presence of oxidizing agents, such as air, or reducing agents, such as coke.
 - Froth flotation is flotation in which air bubbles are introduced into a mixture of finely divided ore or other material with water and a chemical that aids attachment of the bubbles to the particles of the desired material and its recovery as a froth.
 - Gangue is the unwanted impurities present in ore are.
9. Sodium, calcium, aluminium, etc.
10. This is because iron is less reactive than carbon.
11. Cost, position in the reactivity series, energy.
12. **Complete**

“Metals come from the Earth's **crust**. Some metals like **gold** are very unreactive and are found as **native** in their **elemental** state. Metals such as zinc, lead and **iron** are found combined with oxygen in compounds. These metals can be **extracted** using chemical reactions. The metal oxides are **reduced** as oxygen is removed from the compound”.
13. Most of metals in nature exist in oxidized form.

Lesson 2: Methods of extraction of copper

a. Prerequisites/Revision/Introduction:

Students will learn better the methods of copper extraction if they have knowledge on chemistry and uses of metals (unit 6 and unit 8 in Senior 4), redox reactions and reactivity series of metals (unit 17 in Senior 4), electrolysis (unit 13 in Senior 5) and individual chemistry of transition metals (unit 1 in Senior 6).

b. Teaching resources

You can use worksheets/books, projectors /chalkboard, etc.

c. Learning activities

- As a facilitator, you are expected to guide learners to learn by doing **activity 2.2**, as described below.
- Give the activity to students. This activity has to be done in group of 4 and it takes at most 20 min.
- Choose randomly some students in different groups to present their findings.
- Allow some other students to comment about the findings presented by their colleagues.
- Give your feedback making clear where is the missing relevant information especially in the description of the process in which copper metal is extracted.
- Through different small verbal questions, help the students to make the conclusion themselves.
- To check their understanding, give them the **Checking Up 2.2** in the Student's Book as an individual work. The feedback will be given in the next session after the correction.
- You may refer to the proposed answers of the **Activity 2.2** and the **Checking up 2.2**

Answers to Activity 2.2

1. Names of the main ores of Copper.

ORE MINERAL	FORMULA
Cuprite	Cu_2O
Chalcocite	Cu_2S
Bornite	$2\text{Cu}_3\text{S} \cdot \text{CuS} \cdot \text{FeS}$
Malachite	$\text{CuCO}_3 \cdot \text{Cu}(\text{OH})_2$
Azurite	$\text{Cu}_3(\text{CO}_3)_2(\text{OH})_2$
Chalcopyrite	CuFeS_2

2. Description of the full process to extract copper from its ores. See the Student's Book.

3. How copper is useful in our daily life. See the uses of copper (Unit 1, Student's Book).

Answers to the Checking up 2.2

1 Copper uses: Electrical equipment (wires, motors, etc); Coinage, Construction (Roofing, plumbing, etc).

2.Process of extraction (See the Student's Book)

3.Extraction from chalcopyrite versus that from cuprite

Copper, Cu, is mainly extracted from the ore chalcopyrite, CuFeS_2 , (sulphide ore) in a three stage process.

- In the **first stage**, chalcopyrite is heated with silicon dioxide and oxygen

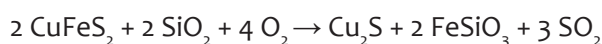

- In the **second stage**, the copper (I) sulphide is roasted with oxygen at a high temperature in a reverberatory furnace giving copper (II) oxide.

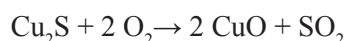

- In the **third stage**, the copper (II) oxide is reduced by heating with carbon.

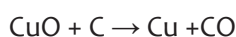

Copper can be extracted from the ore **cuprite** (non-sulphide ore) by a different process involving **three separate stages**:

Step 1: Reaction of the ore (over quite a long time and on a huge scale) with a dilute acid such as dilute sulphuric acid to produce a very dilute copper (II) sulphate solution.

Step 2: Concentration of the copper (II) sulphate solution by solvent extraction.

Step 3: Electrolysis of the new solution.

Lesson 3: Methods of extraction of Iron

a. Prerequisites/Revision/Introduction:

Students will learn better the methods of iron extraction if they have knowledge on chemistry and uses of metals (unit 6 and unit 8 in Senior 4), redox reactions and reactivity series of metals (unit 17 in Senior 4), electrolysis (unit 13 in Senior 5) and individual chemistry of transition metals (unit 1 in Senior 6).

b. Teaching resources

You can use worksheets/books, projectors /chalkboard, etc.

c. Learning activities

- As a facilitator, you are expected to guide learners to learn by doing **activity 2.3**, as

described below.

- Give the activity to students. This activity has to be done in group of 4 and it takes at most 20 min.
- Choose randomly some students in different groups to present their findings.
- Allow some other students to comment about the findings presented by their colleagues.
- Give your feedback making clear where the relevant information is missing especially in the description of the process in which iron metal is extracted, what happens in the blast furnace and the alloys of iron.
- Through different small verbal questions, help the students to make the conclusion themselves.
- To check their understanding, give them the **Checking Up 2.3** in the Student's Book as a homework that must be submitted individually. The feedback will be given in the next session after the correction.
- You may refer to the proposed answers of the **Activity 2.3** and the **Checking up 2.3**

Proposed Answers to Activity 2.3

1. Haematite, magnetite, etc
2. Full process (See the Student's Book)
3. Main different forms of iron, its properties and their respective uses (See the Student's Book)

Answers to Checking up 2.3

1. Iron is extracted using the Blast Furnace
 - a. Ore of iron, coke and limestone
 - b. It is heated using coke as a fuel. $C + O_2 \rightarrow CO_2$
 - c. The main reducing agent is carbon monoxide (CO). It is produced by reduction of CO_2 by coke. $CO_2(g) + C(s) \rightarrow 2 CO(g)$
 - d. $Fe_2O_3(s) + 3 CO(g) \rightarrow 2 Fe(l) + 3 CO_2(g)$
 - e. The other is carbon (coke). $Fe_2O_3(s) + 3 C(s) \rightarrow 2 Fe(l) + 3 CO(g)$
2. To be continuous means that it does not stop, it continues to work. This is advantageous mainly in terms energy used. When it allowed to cool and heat again will cause consumption of much energy but also sops the production.

Lesson 4: Methods of extraction of Tin

a. Prerequisites/Revision/Introduction:

Students will learn better the methods of tin extraction if they have knowledge on chemistry and uses of metals (unit 6 and unit 8 in Senior 4), redox reactions and reactivity series of metals (unit 17 in Senior 4), electrolysis (unit 13 in Senior 5) and individual chemistry of transition metals (unit 1 in Senior 6).

b. Teaching resources

You can use worksheets/books, projectors /chalkboard, etc.

c. Learning activities

- As a facilitator, you are expected to guide learners to learn by doing **activity 2.2**, as described below.
- Give the activity to students. This activity has to be done in group of 4 and it takes at most 15 min.
- Choose randomly some students in different groups to present their findings.
- Allow some other students to comment about the findings presented by their colleagues.
- Give your feedback making clear where is the missing relevant information especially in the description of the process in which tin metal is extracted, its main ore and the places in Rwanda where it can be found.
- Through different small verbal questions, help the students to make the conclusion themselves.
- To check their understanding, give them the **Checking Up 2.4** in the Student's Book as an individual homework. The feedback will be given in the next session after the correction.
- You may refer to the proposed answers of the **Activity 2.4** and the **Checking up 2.4**

Answers to Activity 2.4

1. Cassiterite, SnO_2 . It is extracted in some regions such as: Rutongo, Rwinkwavu, Gatumba, etc.
2. Process (See the Student's Book)
3. Properties and uses of tin. (See Student's Book)

a. Checking up

Answers to Checking up 2.4

1. Ores of tin. (See the Student's Book)
2. Extraction of tin from tin oxide. (See the Student's Book)
3. This chemical reaction is reduction
4. See uses of tin (In the Student's Book)

Lesson 5: Methods of extraction of Zinc

a. Prerequisites/Revision/Introduction:

Students will learn better the methods of zinc extraction if they have knowledge on chemistry and uses of metals (unit 6 and unit 8 in Senior 4), redox reactions and reactivity series of metals (unit 17 in Senior 4), electrolysis (unit 13 in Senior 5) and individual chemistry of transition metals (unit 1 in Senior 6).

b. Teaching resources

You can use worksheets/books, projectors /chalkboard, etc.

c. Learning activities

- As a facilitator, you are expected to guide learners to learn by doing **activity 2.5**, as described below.
- Give the activity to students. This activity has to be done in pairs and it takes 10 to 15 min.
- Choose randomly some students in different groups to present their findings.
- Allow some other students to comment about the findings presented by their colleagues.
- Give your feedback making clear where is the missing relevant information especially in the description of the process in which zinc metal is extracted.
- Through different small verbal questions, help the students to make the conclusion themselves.
- To check their understanding, give them the **Checking Up 2.5** in the Student's Book as a work in pairs. The feedback will be given in the next session after the correction.
- You may refer to the proposed answers of the **Activity 2.5** and the **Checking up 2.5**

Answers to Activity 2.5

1. Main ores of zinc. (See the Student's Book)
2. See the steps for zinc blende (In the Student's Book)
3. See uses of zinc (In the Student's Book)

Answers to Checking up 2.5

1. Uses of Zinc (See the Student's Book)
2. Extraction of zinc from zinc oxide. (See the Student's Book)
3. Zinc is extracted by removing oxygen from zinc oxide.
 - a. Reduction
 - b. Using a reducing agent like carbon. $\text{ZnO} + \text{C} \rightarrow \text{Zn} + \text{CO}_2$
4. Different methods by which the impurities in zinc extracted can be removed. (See the Student's Book)

Lesson 6: Methods of extraction of Sodium

a. Prerequisites/Revision/Introduction:

Students will learn better the methods of sodium extraction if they have knowledge on importantly chemistry and uses of metals (unit 6 and unit 8 in Senior 4), redox reactions and reactivity series of metals (unit 17 in Senior 4) and mainly electrolysis (unit 13 in Senior 5).

b. Teaching resources

You can use worksheets/books, projectors /chalkboard, etc.

c. Learning activities

- As a facilitator, you are expected to guide learners to learn by doing **activity 2.6**, as described below.
- Give the activity to students. This activity has to be done individually and it takes at most 15 min.
- Choose randomly some students in different groups to present their findings.
- Allow some other students to comment about the findings presented by their colleagues.
- Give your feedback making clear where is the missing relevant information especially in the description of the process in which sodium metal is extracted.
- Through different small verbal questions, help the students to make the conclusion themselves.
- To check their understanding, give them the **Checking Up 2.6** in the Student's Book as an individual work. The feedback will be given in the next session after the correction.
- You may refer to the proposed answers of the **Activity 2.6** and the **Checking up 2.6**

Answers to Activity 2.6

1. Sodium is mainly available in salt rocks and precisely in NaCl, sodium vapour lamps for street lighting (yellow/orange) etc...
2. This is because sodium is very reactive.
3. See the Student's Book.

Answers to Checking up 2.6

1. Because sodium is higher in the reactivity series, it is more reactive than carbon. It is more reducing agent than carbon. Electrolytic method is used instead of reduction with carbon.
2. High melting point of the ore (NaCl) and when that point is reached, there is a fog formed between sodium chloride electrolyte and sodium metal, difficult or even impossible to separate.
3. In sodium extraction, fused (molten) NaCl is used rather than the dissolved (aqueous) NaCl because:
4. (d) Electrolysis of molten NaCl gives Na metal at the cathode but that of aqueous NaCl gives H₂ gas.

Lesson 7: Methods of extraction of Aluminium

a. Prerequisites/Revision/Introduction:

Students will learn better the methods of Aluminium extraction if they have knowledge on chemistry and uses of metals (unit 6 and unit 8 in Senior 4), redox reactions and reactivity series of metals (unit 17 in Senior 4) and importantly electrolysis (unit 13 in Senior 5).

b. Teaching resources

You can use worksheets/books, projectors /chalkboard, etc.

c. Learning activities

- As a facilitator, you are expected to guide learners to learn by doing activity 2.7, as described below.
- Give the activity to students. This activity has to be done in group of 4 and it takes at most 15 min.
- Choose randomly some students in different groups to present their findings.
- Allow some other students to comment about the findings presented by their colleagues.
- Give your feedback making clear where is the missing relevant information especially in the description of the process in which aluminium metal is extracted.
- Through different small verbal questions, help the students to make the conclusion themselves.
- To check their understanding, give them the **Checking Up 2.7** in the Student's Book as an individual work. The feedback will be given in the next session after the correction.
- You may refer to the proposed answers of the **Activity 2.7** and the **Checking up 2.7**

Answers to Activity 2.7

Findings of the research

1. The main ore is bauxite.
2. Because aluminium, is more reactive than carbon. It is found above carbon in the reactivity series.
3. The way the main ore is purified (See the Student's Book).
4. The process by which aluminium is extracted from the purified ore by electrolytic method (See the Student's Book).
5. The properties and uses of aluminium (See the Student's Book).

Answers to Checking up 2.7

Consider the electrolytic extraction of aluminium.

1. .Bauxite
2. To reduce the melting point of alumina (Al_2O_3)
3. The process by which the ore of aluminium is purified. (See the Student's Book).
4. Half-equations for the reactions at each electrode, and write an overall equation for the reaction
At the cathode: $\text{Al}^{3+} + 3\text{e}^- \rightarrow \text{Al}$
At the anode: $2\text{O}^{2-} \rightarrow \text{O}_2 + 4\text{e}^-$
5. Each electrode is made in graphite
6. Explanations.
 - a. Because anode reacts with oxygen produced there and there end up time to time.
 - b. Because the purification (or concentration) is difficult, melting aluminium oxide is highly difficult because of its high melting point, etc.
 - c. Aluminium is recycled because it is the simpler method of obtaining aluminium comparing to the extraction from its ore.
7. Uses of aluminium and the properties responsible for each use. (See the Student's Book).

Lesson 8: Methods of extraction of Tungsten (Wolfram)

a. Prerequisites/Revision/Introduction:

Students will learn better the methods of wolfram extraction if they have knowledge

on chemistry and uses of metals (unit 6 and unit 8 in Senior 4), redox reactions and reactivity series of metals (unit 17 in Senior 4), electrolysis (unit 13 in Senior 5), individual chemistry of transition metals (unit 1 in Senior 6) and also you must make a field trip where wolfram is mined and extracted in your nearby area, thus before studying the lesson, students will have already knowledge and skills about some works in extraction of wolfram.

b. Teaching resources

You can use worksheets/books, projectors /chalkboard, etc.

c. Learning activities

- Remember to follow **activity 2.8** before this lesson. Their findings of the researches of the students will be summarized in the groups of 4.
- Before the study this lesson, make sure that the field trip at the mining site of wolfram was done. Students are now expected to have enough knowledge about the extraction of wolfram because the activity tells them to make possible resource after the field trip to have deep understanding about what happen in extracting wolfram.
- Ask them to submit their summaries and let each group present briefly what they found.
- Allow some other students to comment about the findings presented by their colleagues.
- Give your feedback making clear where is the missing relevant information especially in the description of the process in which wolfram is extracted.
- Through different small verbal questions, help the students to make the conclusion themselves.
- To check their understanding, give them the **Checking Up 2.8** in the Student's Book as an individual work. The feedback will be given in the next session after the correction.
- You may refer to the proposed answers of the **Activity 2.8** and the **Checking up 2.8**

Answers to Activity 2.8

1. Visit the nearby mining sites of wolfram and make a field report.
2. Research findings:
 - a. Wolframite and Scheelite.
 - b. As the extraction of tin goes usually with wolframite, the areas at which cassiterite is found, also wolframite are together with it. Thus, in Rwanda we can say: Rutongo, Rwinkwavu, etc.
 - c. Wolfram extraction use hydrogen as the reducing agent while zinc use carbon.
 - d. Full description of the extraction process of tungsten from its ore.
 - e. See Student's Book

Answers to Checking up 2.8

1. a. Wolframite, scheelite, etc.

b. Balanced equation of the reduction reaction of tungsten oxide.



2. Most tungsten ores contain few proportion of tungsten, thus, a very high amount of gangue material must be separated. When they are close, it helps to save (energy and money as well).

3. Physical properties of tungsten and the uses associated to these properties (See the Student's Book in uses of tungsten).

Lesson 9: Methods of extraction of Tantalum

a. Prerequisites/Revision/Introduction:

Students will learn better the methods of wolfram extraction if they have knowledge on chemistry and uses of metals (unit 6 and unit 8 in Senior 4), redox reactions and reactivity series of metals (unit 17 in Senior 4), electrolysis (unit 13 in Senior 5), individual chemistry of transition metals (unit 1 in Senior 6) and also you must make a field trip where tantalum is mined and extracted in your nearby area, thus before studying the lesson, students will have already knowledge and skills about some works in extraction of tantalum.

b. Teaching resources

You can use worksheets/books, projectors /chalkboard, Periodic Table, etc.

c. Learning activities

- Remember to follow **activity 2.9** before this lesson. Their findings of the researches of the students will be summarized in the groups of 4.
- Before the study this lesson, make sure that the field trip at the mining site of wolfram was done. Students are now expected to have enough knowledge about the extraction of wolfram because the activity tells them to make possible resource after the field trip to have deep understanding about what happen in extracting wolfram.
- Ask them to submit their summaries and let each group present briefly what they found.
- Allow some other students to comment about the findings presented by their colleagues.

- Give your feedback making clear where is the missing relevant information especially in the description of the process in which wolfram is extracted.
- Through different small verbal questions, help the students to make the conclusion themselves.
- To check their understanding, give them the **Checking Up 2.9** in the Student’s Book as an individual work. The feedback will be given in the next session after the correction.
- You may refer to the proposed answers of the **Activity 2.9** and the **Checking up 2.9**

Answers to Activity 2.9

1. Visit the nearby mining sites of tantalum and make a field report.
2. Findings of the research about tantalum:
 - a. *Tantalum is a hard, heavy, shiny, grayish-blue metal that is very stable, almost impervious (impermeable) to air, water and all but a few acids. It has the third highest melting point of all elements (over 3000 °C), and its primary use is in capacitors for electronic applications, and for vacuum furnace parts.*
 - b. *Description of the extraction of tantalum from its main ore tantalite. (See Student’s Book).*

Answers to Checking up 2.9

The ore of tantalum is widely known in Rwanda under the name “coltan” abbreviation of columbite-tantalite.

1. How tantalum is mined (See Student’s Book)
2. How tantalum is processed (See Student’s Book)
3. Uses of tantalum (See Student’s Book)
4. MIBK is a solvent extractant in production of tantalum oxide and highly purified solutions of tantalum and niobium..

Lesson 10: Dangers associated with extraction of metals

a. Prerequisites/Revision/Introduction:

Students will learn better the dangers associated with metal extraction after having enough knowledge about the metallurgical processes involved in the extraction.

Linking this with other subjects studied in lower levels like Geography, Biology, etc, the students must be aware of all dangers associated with the extraction of metals and this will help them to suggest the ways to prevent the dangers associated with these processes of extraction of metals.

b. Teaching resources

You can use worksheets/books, projectors /chalkboard/Periodic Table, etc.

c. Learning activities

- As a facilitator, you are expected to guide learners to learn by doing **activity 2.10**, as described below.
- Give the activity to students. This activity has to be done in group of 4 and it takes at most 15 min.
- Choose randomly some students in different groups to present their findings.
- Allow some other students to comment about the findings presented by their colleagues.
- Give your feedback; highlight where there is the missing relevant information of any important danger not given clearly.
- Through different small verbal questions, help the students to make the conclusion themselves.
- To check their understanding, give them the **Checking Up 2.10** in the Student's Book as an individual work. The feedback will be given in the next session after the correction.
- You may refer to the proposed answers of the **Activity 2.10** and the **Checking up 2.10**

Answers to Activity 2.10

Possible common dangers associated with the extraction of metals. (See the Student's Book)

Answers to Checking up 2.10

1. Sources of injuries associated with the extractions of metals are:

Some common injuries from the metal extraction

- Splattering and spills of molten metal and slag resulting in burns;
 - Gas explosions and explosions from contact of molten metal with water;
 - Collisions with moving vehicles;
 - Falls of heavy objects;
 - Falls from a height,
 - Lipping and tripping injuries from obstruction of floors and passageways
2. Ways you can prevent from heat illnesses.
- Water screens or air curtains in front of furnaces,
 - heat-protective clothing and air-cooled suits,
 - allowing sufficient time for acclimatization,
 - 3.work breaks in cool areas
 - An adequate supply of beverages for frequent drinking.
 - 4.Dust and fume emissions can be controlled by
 - Enclosure,
 - Automation of processes,
 - Local and dilution exhaust ventilation,
 - Wetting down of materials,
 - Reduced handling of materials and other process changes.
 - Respiratory protection

Lesson 11: Preventive measures associated with metal extraction.

a. Prerequisites/Revision/Introduction:

Students will learn better the preventive measures associated with metal extraction after having enough knowledge about the metallurgical processes involved in the extraction. Linking this with other subjects studied in lower levels like Geography, Biology, etc, the students are able to suggest even how to prevent the dangers associated with these processes of extraction of metals.

b. Teaching resources

You can use worksheets/books, projectors /chalkboard, etc.

c. Learning activities

- As a facilitator, you are expected to guide learners to learn by doing **activity 2.11**, as described below.
- Give the activity to students. This activity has to be done in group of 4 and it takes

at most 15 min.

- Choose randomly some students in different groups to present their findings.
- Allow some other students to comment about the findings presented by their colleagues.
- Give your feedback making clear where is the missing relevant information especially in the description of the process in which copper metal is extracted.
- Through different small verbal questions, help the students to make the conclusion themselves.
- To check their understanding, give them the **Checking Up 2.11** in the Student's Book as a work in pairs. The feedback will be given in the next session after the correction.
- You may refer to the proposed answers of the **Activity 2.11** and the **Checking up 2.11**

Activity 2.11

Use recommendations given in Student's Book

Checking up 2.11

The main aspects that should be taken into account as preventive measures (See Student's Book)

2.6. Summary of the unit

Metals are very useful. The method used to extract metals from the ore in which they are found depends on their reactivity. Concentrating the ore ("dressing" or "*benefaction of ore*") means "removal of gangue from ore" and this may be done by *chemical* or *physical* means.

Copper metal is mainly extracted from the ore chalcopyrite, CuFeS_2 , in a three stage process where chalcopyrite is first heated with silicon dioxide and oxygen to give copper (I) sulphide, then copper (I) sulphide is roasted with oxygen at a high temperature in a reverberatory furnace giving copper (II) oxide. Finally, the copper (II) oxide is reduced by heating with carbon to give blister copper (about 98 - 99.5% pure). This copper obtained may be purified using electrolysis method where the anode is made the impure copper and the cathode the pure copper. The electrolyte used here is copper (II) sulphate solution. Copper is useful in electrical wiring, plumbing, coinage, etc.

The most commonly used iron ores are haematite, Fe_2O_3 , and magnetite, Fe_3O_4 . During the extraction of iron, the ore is introduced in a giant chimney called blast furnace together with coke (acting as fuel and reducing agent) and limestone (used to remove silica waste materials).

This furnace is heated using the hot waste gases from the top and several reactions take place before the iron is finally produced by reduction of the ore by carbon (coke) or carbon monoxide formed in the furnace. The uses of iron are varied depending on the form and alloys (known as steel), for example cast iron is used in heavy cookware,

stainless steel is used in cutlery, titanium steel in spacecraft, etc.

On industrial scale sodium metal is extracted by “Down’s Process” which is based on the electrolysis of fused salt (NaCl). The anode is a graphite rod and the cathode is a ring iron. When NaCl is fused, a “metallic fog” will form between the electrolyte (NaCl) and the metallic sodium (Na) being formed and this is impossible to separate. This allows the use of a mixture of NaCl and CaCl_2 as electrolyte in Down’s cell and after these metals (Na and Ca) will be separated because they have different densities. Sodium is used as a potential coolant, in street lighting, etc.

The chief ore of aluminium is called bauxite ($\text{Al}_2\text{O}_3 \cdot 2\text{H}_2\text{O}$) which is purified (by a Bayer process) to yield aluminium oxide, from which aluminium can be extracted. Aluminium is too high in the electrochemical series (reactivity series) so it is extracted by electrolysis. But first the aluminium oxide must be made molten so that electricity can pass through it. The melting point of aluminium oxide is so high and here the cryolite is used to reduce this melting temperature. The electrodes are made in graphite and oxygen produced at the anode reacts with carbon (graphite) electrode to produce carbon dioxide, and thus this electrode has to be replaced time to time as it is being used up. The properties of aluminium makes it to be used in many areas, for example it is used in aircraft, transmission of electricity, etc, because it has a low density, it has a high electrical conductivity, it has a good appearance, etc.

The principal tin ore is cassiterite (SnO_2) known as Tin stone. Extraction of tin from tin stone is done into four main steps namely concentration, roasting, leaching (and washing), smelting and refining. The refining (to obtain pure tin), thermal or electrolytic means may be used but much purer tin is obtained by the electrolysis of SnCl_2 where the impure tin is made anode, while the cathode is pure tin. Tin is mainly used to prevent corrosion of metals and as alloys such as bronze (tin and copper) and solder (tin and lead).

The chief tantalum ore is tantalite. Tantalum has the third highest melting point of all elements (over 3000°C), and its main use is in capacitors for electronic applications. Tantalum mining takes place in very few countries; Rwanda, DRC, Brazil and China, being on the top. The concentrate containing tantalum is treated with a mixture of hydrofluoric and sulphuric acids at high temperatures to remove impurities and the mixture obtained is separated by solvent extraction. Finally, this tantalum oxide will be reduced with molten sodium to produce tantalum metal in powder form.

Zinc is extracted from zinc blende, ZnS (its main ore) in various steps such as concentration (by froth floatation method), roasting (in a reverberatory furnace), smelting (in a vertical container) and purification (by either fractional distillation or electrolysis method). In the fractional distillation, the impurities such as Pb, Fe and Cd are removed and as a result pure zinc is left.

In the electrolysis method, a zinc rod acts as a cathode, while the impure zinc serves as an anode; here ZnSO_4 and dil H_2SO_4 are mixed up and used as an electrolyte. Zinc is widely used in galvanizing iron, in alloys such as brass (zinc + copper) and its oxide

(ZnO) is widely used in the manufacture of very many products (such as paints, rubber, cosmetics, pharmaceuticals, etc).

The main ore minerals of tungsten are wolframite $[(\text{Fe}, \text{Mn})\text{WO}_4]$ and scheelite (CaWO_4) . Tungsten is also known as “Wolfram” and is more resistant to fracturing than diamond and is much harder than steel. It has a high melting point which makes it to be majorly used in light bulb filaments which heat up to 2000 °C. Modern processing methods dissolve scheelite and wolframite concentrates are converted into an ammonium tungstate solution by solvent extraction or ion exchange resins. By crystallization, high purity ammonium paratungstate (APT) is obtained which can then be heated with hydrogen to form tungsten oxide (WO_3) which is reduced by a stream of hydrogen to form the tungsten metal.

The dangers associated with extraction of metals are mainly injuries, heat illnesses, respiratory diseases, pollution, global warming, erosions, etc

The best preventive measures associated with metal extractions are those taken at the planning stage of a new plant or process where modern, health and environmental friendly production facilities are planned.

2.7. Additional information for teachers

Reasons for recycling Aluminium oxide, titanium oxide and iron oxide are all very abundant in the earth’s crust, and shortages are not anticipated. There are, however, a number of important reasons why recycling is desirable:

- Recycling generally uses less energy than extraction
- Mines and quarries are unsightly
- The extraction process produces polluting gases like sulphur dioxide and carbon dioxide
- Disposing of scrap metal is difficult
- Most scrap contains a high percentage of the desired metal, so the process can be quite efficient

Problems with recycling

Collection of scrap metal

Scrap metal needs to be collected from wherever it is used. There are costs involved in doing this.

Removing the desired metal from the rest of the scrap

Once collected, the desired metal needs to be separated from the other metals. Unless the metal is magnetic, this needs to be done manually. There are costs involved in doing this.

Purifying the desired metal

Once separated, the metal needs to be returned to the purity required for it to be useful. There are costs involved in doing this.

Methods of recycling

Aluminium

- Most of the recycled aluminium is from drinks cans and foil.
- The cans are collected at recycling points.
- The cans are shredded and the paint is removed.
- The metal is melted down into large ingots
- The ingots are rolled into sheet metal from which more cans are cut.

Iron

- Most of the recycled iron is from old trains, ships and cars.
- Because of the large size of these objects, the collection is done by specialist metal reclaiming companies.
- The objects are cut into a manageable size.
- The iron is separated from the other metals using a large magnet.
- The scrap is melted and purified in the Basic Oxygen Process.

The purity required for the commercial use of titanium and tungsten means that recycling is not commercially viable.

2.8. End unit assessment

Assessment standards:

- Investigate the properties of a range of metals and relate these to their method of extraction and uses, independently evaluating evidence to reach valid conclusions .
- Explore the best possible solutions to address the dangers associated with metal extraction to suggest preventive measures

ANSWERS TO END UNIT QUESTIONS

1. (d) Aluminium
2. (d) An Alloy
3. (c) Copper and Tin
4. (c) Gold
5. (b) Iron

6. (b) Ores
7. (b) homogeneous solid mixture of two or more metals
8. (c) Sulphur
9. (c) Zinc
10. (c) *Its ore minerals include scheelite*
11. *Complete with the terms applied in the Extraction of iron from haematite in industry (Blast Furnace).*
- a. Raw materials: Ore of iron, limestone and coke
- A mixture of iron ore, limestone and coke is added at the top of the furnace. Hot air is blown into the furnace from the bottom. A chain of chemical reactions occur:
- b. Carbon reacts with excess oxygen to form carbon dioxide.
Equation: $C(s) + O_2(g) \rightarrow CO_2(g)$
- c. The hot carbon dioxide rises in the furnace and is reduced by carbon (coke) to form carbon monoxide. Equation: $CO_2(g) + C(s) \rightarrow 2 CO(g)$

d. Carbon monoxide is a **reducing** agent. It **reduces** iron (III) oxide in haematite to form hot molten **iron**.



e. The hot molten iron is then run out from the bottom of the furnace.

f. The formula of limestone: **CaCO₃**

Limestone breaks up into **calcium oxide** and **carbon dioxide** when heated.

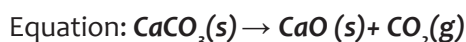

g. Calcium oxide helps to remove **silica/sand** (the impurities) to form a liquid '**slag**'.

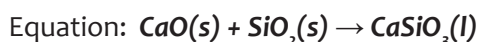

12. a. See reduction by carbon (example: extraction of iron), electrolysis (example: extraction of sodium) and reduction by hydrogen (extraction of tungsten).
Reactions and conditions; see the Student's Book.

b. (i) Oxides are abundant in nature, they are naturally occurring.

(ii) Greenhouse effect/Global warming/toxic environment.

13. a. Haematite, Fe₂O₃, and magnetite, Fe₃O₄

b. See Student's Book.

14. a. Uses of aluminium, copper, zinc, and iron. (See Student's Book)

b. The extraction of aluminium is expensive because it requires to melt aluminium oxide which has a high melting point, the purification process is difficult, it releases carbon dioxide in atmosphere which lead to many taxes.

15. Equation for the reaction:



Carbon is not used as the reducing agent because it would produce a carbide not tungsten.

a. Suggest one advantage (other than purity of the product) and one disadvantage of using hydrogen as the reducing agent on an industrial scale.

b. Advantages:

- Hydrogen is easily obtained.
- Hydrogen is a cheap reagent

c. Disadvantages:

- The energy cost is high
- Using a flammable gas such as hydrogen at high temperatures is very dangerous

16 . a. Roasting $2 \text{ZnS} + 3 \text{O}_2 \rightarrow 2 \text{ZnO} + 2 \text{SO}_2$

b. It is more reactive

c. It would form a tungsten carbide rather than reducing.

17. a. (i) Balanced equation. $\text{Cu}_2\text{S} + 2 \text{O}_2 \rightarrow 2 \text{CuO} + \text{SO}_2$

(ii) Sulphur dioxide causes acid rain.

b. $\text{CuO} + \text{C} \rightarrow \text{Cu} + \text{CO}_2$ Oxygen is removed by carbon because carbon is more reactive than copper.

c. From the diagram in the Student's Book.

(i) Electrolysis/electroplating

(ii) Electrical wiring / appliances / coins / pipes / cladding for buildings / jewellery / making alloys

d. Recycling of copper may be better than extracting copper from its ores.

- Less acid rain (pollution)
- Copper reserves last longer / conserved or do not run out
- Energy for extraction (saved) or less energy required
- Less mining / quarrying
- Less waste (copper) / electrical appliances dumped or less landfill against recycling
- Collection problems
- Transport problems
- Difficult to separate copper from appliances
- Energy used to melt the collected copper

2.9. Additional activities

Remedial Questions

1. Top of Form

Write the names of eight important metals. Give an example of one important ore of each metal.

What is the difference between an ore and a mineral?

Name some important methods of concentrating the ores.

Which method of concentration is applied in the following cases?

- Magnetic ores
- Sulphide ores
- Bauxite ore

Which metal is extracted from the mineral zinc blende?

State the nature of materials used for constructing cathodes and anodes in the

electrolytic cell for refining of copper. Write chemical equations for the reactions which take place.

Which method is used for the refining of metals that are easily fused?

Which metals are refined by polling?

Name a metal which is purified by distillation.

Name any three elements which are refined by electrolytic refining.

What is role of cryolite in the extraction of Al.

Which one is responsible to reduce Fe_2O_3 to Fe: C or CO?

Answers to remedial questions

1. Sodium (Na), Aluminium (Al), Silver (Ag), Iron (Fe), Zinc (Zn), Lead (Pb), Gold (Au), Mercury (Hg).

2. Ores: rock salt, bauxite, argentite, haematite, zincite, galena, native gold, cinnabar, respectively.

Mineral is a naturally occurring material in which a metal or its compound occurs.

3. An ore is that mineral in which metal is present in large quantity and from which the metal can be extracted in pure and high quality, economically.

4. Gravity separation, magnetic separation, froth floatation and chemical method.

a. Magnetic separation method

b. Froth floatation method

c. Chemical method

5. Zinc.

6. Cathode : Pure metal At Cathode : $\text{Cu}^{2+} + 2\text{e} \rightarrow \text{Cu}$

Anode : Impure metal At Anode : $\text{Cu} \rightarrow \text{Cu}^{2+} + 2\text{e}$

7. Liquefaction

8. Copper and tin

9. Zinc

10. Copper, Silver and Tin

11. Decrease the melting point of alumina/ to increase the conductance

12. CO

Consolidation Questions

1. Explain the following terms: Calcination, Roasting, Smelting, Flux and Slag.

2. Which is the cheapest and most abundant reducing agent employed in the extraction of metals?

3. Name the process which is used for converting sulphide ores into oxides.

4. How are oxide ores reduced?

- Name few materials which are used as flux in metallurgical processes.
- What happens to (a) Bauxite and (b) Calamine ores during calcination?

Answers to consolidation questions

1. Calcination: it involves heating of the ore in a limited supply of air to a temperature that the ore does not melt.

Roasting: It involves heating of the ore in a free supply of air to a temperature that the ore does not melt.

Smelting: The extraction of metal in the fused state is termed smelting. The ore is reduced by carbon to the free metal.

Flux: it is a chemical substance which combines with gangue at higher temperatures to form easily fusible material called slag.

Slag is a fusible chemical compound formed by the reaction of flux with gangue. Slag is not soluble in the molten metal and is thus separated.

2. Carbon in the form of coke.

3. Roasting: $2 \text{ZnS} + 3 \text{O}_2 \rightarrow 2 \text{ZnO} + 2 \text{SO}_2(\text{g})$

4. Oxide ores are reduced to metal by heating them with coke.

5. Silica, borax and other non-metallic oxides are acidic fluxes. Lime stone CaCO_3 is a basic flux.

6. a. $\text{Al}_2\text{O}_3 \cdot 2\text{H}_2\text{O} \rightarrow \text{Al}_2\text{O}_3 + 2 \text{H}_2\text{O}$

b. $\text{ZnCO}_3 \rightarrow \text{ZnO} + \text{CO}_2$

7. The diagram below shows the blast furnace:

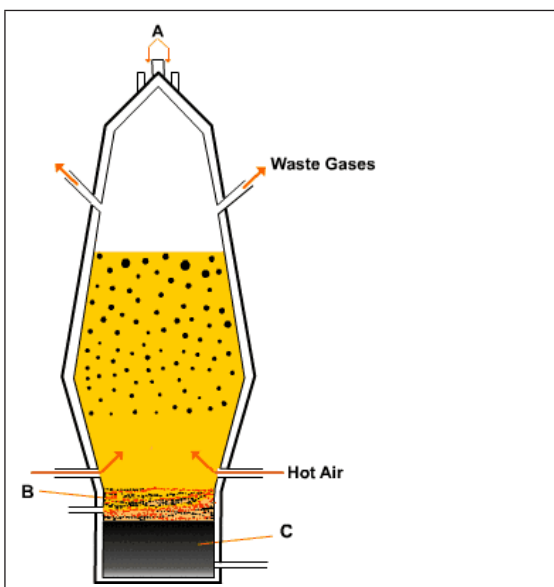
	<p>a) Complete the labels A, B and C. b) What are the main waste gases from the blast furnace?</p> <p>Answer:</p> <p>a. A = iron ore B = slag C = molten iron</p> <p>b. Carbon dioxide Nitrogen</p>
---	--

8. Aluminium metal is produced using electrolysis.

The cell used in this process is shown below:

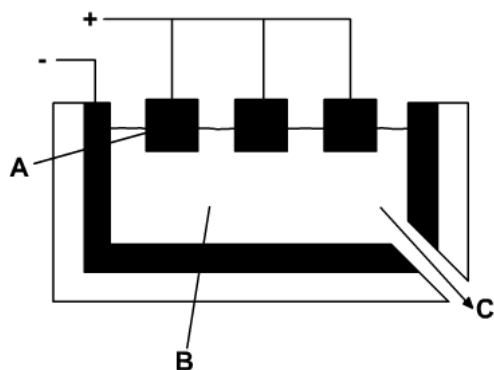

- Complete the labels A, B and C.
- Why is cryolite added to the aluminium ore in this process?
-

Answers:

- (a)** A = graphite electrodes.
B = molten bauxite/aluminium ore.
C = molten aluminium metal.
- (b)** To lower the melting point of the aluminium oxide (so less energy required).

Extended Questions

1. The following questions are about the blast furnace and the production of iron.

- Why are hot blasts of air blown in to the blast furnace?
- Why is limestone added to the blast furnace?

2. Railway lines are welded together using molten iron. The molten iron is made using the thermite reaction where iron oxide is reacted with aluminium powder. Why is this reaction not used to make iron on a large scale?

Answer:

UNIT 3: NPK AS COMPONENTS OF FERTILIZERS

3

3.1. Key unit competence

The learner should be able to analyze the components of quality fertilizers and their benefits, effects of misuse and dangers associated with the substandard fertilizers.

3.2. Prerequisite (knowledge, skills, attitudes and values)

Students will learn better NPK as components of fertilizers when they have an understanding on the following:

- **Unit 2:** Nitrogen and its inorganic compounds (S.3),
- **Unit 12:** Inorganic salts and their properties (S.1),
- **Unit 4:** Effective ways of waste management (S.2),
- **Unit 11:** Solutions and titration (S.5),
- **Unit 7:** Water and its composition (S1),
- **Unit 8:** Air composition and pollution (S.1),
- **Unit 9:** Waste materials (S.1), among others.

3.3. Cross-cutting issues to be addressed

The cross cutting issues that you can have in this unit are:

Environment and sustainability

This crosscutting issue is justified by the following

- a. Fertilisers can cause eutrophication
 - b. Some fertilisers can produce gases which contribute to different environmental effects
- Like ammonium nitrate when is heated at nearly 220°C , it is decomposed into N_2O which is a greenhouse gas.
 - The preparation of ammonium fertilisers requires first to prepare ammonia: in the first reaction (Catalytic oxidation of ammonia) and second reaction produce NO and NO_2 respectively which participates in the destruction of ozone layer

1.
 - a. The air is used to react with the coke/carbon to form carbon dioxide.
 - b. To remove the impurities that are in the iron ore/to form slag.
 - c. Any one from:

Too expensive/aluminium is more expensive than iron.

Too dangerous/aluminium reacts violently with iron oxide.

2. The following questions are about the electrolysis of aluminium oxide.
 - a. Why does the anode need to be replaced regularly?
 - b. Write an equation to show how aluminium ions are changed in to aluminium metal.
 - c. Why can't the blast furnace be used to make aluminium?

Answer:

- a. The carbon/graphite anode reacts with the oxygen made to form carbon dioxide gas.
 - b. $\text{Al}^{3+}(\text{l}) + 3 \text{e}^{-} \rightarrow \text{Al}(\text{l})$
 - c. Aluminium is more reactive than carbon (not too reactive).
3. This question refers to two metals: copper and zinc.
 - a. Explain in detail the extraction and purification of copper and zinc metal
 - b. Give the uses of copper and zinc metals.

Answers: See the transition metals and extraction of metals in the Students book.

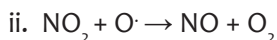
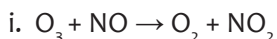

The equation **ii.** above shows how NO_2 participates in the chain reaction leading to the deterioration of ozone layer, when it reacts with oxygen free radical created by CFCs (See Senior five organic chemistry). Fertilisers make soils acidic some make soils (e.g ammonium fertilisers) basic (ammonia in the time of its introduction to the soil).

Standardisation Culture:

Students must be imparted with the culture of standardization.

standardization is the process of making a product conform to a standard established.

Fertilisers must standardized in order to avoid substandard fertilisers and their effects (see student book).

Financial Education

Financial education has a key role of not only improving knowledge of personal but also transforming this knowledge into action. In this unit, students must acquire knowledge/ attitudes and values about making of compost manure and selling it and that may bring

money to students in the family. Also in making compost for example at home, there can be high production and a part of that of the harvest can be sold.

3.4. Guidance on the introductory activity:

Before introducing the lesson, you will have to introduce the whole unit. Let learners therefore attempt activity 3.1. The objectives of this activity are:

- To evaluate whether learners have ability to analyse a given situation
- To evaluate an understanding of a student about cultivation.
- Discover the new lesson

Methodological steps and correction of introductory activity

Introductory activity in student's book S6,

As a guide,

- Give the introductory activity to each learner (individual work)
- Give 5 min to the class in order to complete the introductory activity
- Tell learners to exchange their answers on papers and then they exchange ideas about the introductory activity
- Select four students to write the answers found in their pairs
- Guide learners to make a conclusion.

The expected answer for introductory activity: The person who harvested a small quantity of irish potatoes did not put **fertilisers**.

3.5. List of lessons/sub-heading

#	Lesson title	Learning objectives	Periods
1	Types of fertilizers	Classify the fertilizers in terms of composition.	2
2	Components of a fertilizer	<ul style="list-style-type: none"> • State the major constituents of the fertilizers. • Identify the characteristics of a good fertilizer. • Interpret the labels on the fertilizer containers. • Develop sense of responsibility in using the fertilizers. 	2

3	The manufacture of fertilizers	<ul style="list-style-type: none"> State the chemical reactions involved in the manufacture of the fertilizers. Briefly describe the manufacture of the fertilizers. 	1
4	Advantages/disadvantages of the use of organic and inorganic fertilizers	<ul style="list-style-type: none"> State the advantages or disadvantages of using the fertilizers. Choose the effective ways of applying the fertilizers. Appreciate the use of the fertilizers in increasing the crop production. 	1
5	Dangers of the use of substandard fertilizers	Identify the effects of misuse of the fertilizers and the dangers of substandard fertilizers.	1
	End unit Assessment		1

Lesson 1: Types of fertilisers

This is the first lesson of unit 3 and is a single lesson. That is to say it has only one period (40 minutes). The first lesson also covers the introduction of the whole unit.

a. Prerequisites/Revision/Introduction:

Students will learn better the types of fertilisers if they have some understanding on cultivation techniques and on the types of plants.

b. Teaching resources:

- Books, Internet,
- sample of organic fertiliser or compost bin containing organic fertiliser
- Samples of inorganic fertilisers in their sacs (containers)

c. Learning activities:

Before introducing the lesson, you will have to introduce the whole unit. Let learners therefore attempt **activity 3.1** which leads students to the first lesson of the unit.

Answers to Activity 3.1

In activity (3.1.A), student's book S6,

- A . Orally ask learners the questions in activity (3.1.A)

The expected answers for activity (3.1.A)

- a. To supply nutrients to plants in order to increase the crop production.
- b. Students will answer according to the information they have

For activity (3.1.B), student's book S6,

(B)Put your students in groups of 3 to 4

- Give the activity (3.1.B) to students (containing instructions)
- Give to students this book or other relevant resources
- Invite representatives of groups to presents their group findings (four presentations).
- Ask students to comment on evaluate the findings presented by their fellows
- Ask some questions to assess achievement of instructional objective (each student works individually). Avoid intervening directly on the questions above
- Basing on the answers given by learners, either you can give a homework about the lesson taught, the next lesson, or both.

Answers to Checking up 3.1

The two main types of fertilisers are organic and inorganic fertilisers and see table 3.1 in student 'book.

Lesson 2: Components of a fertilizer

a. Prerequisite knowledge, skills, and attitudes and values:

Students will learn better the components of a fertiliser when they have an understanding on the nitrogen cycle, and on solution and titration (especially on back titration).

b. Teaching resources:

- Books
- Internet
- Sample of organic fertiliser or compost bin
- Samples of inorganic fertilisers in their sacs (containers)
- Plot of land where plants have been planted with different conditions (without a fertilisers, and without fertilisers).

c. Learning activities:

As a guide, the teacher is expected to guide learners through the following steps:

Activity 3.2

For activity (3.2.A), student's book S6,

- Give the activity (3.2.A) to learners (Individual work)
- Give 3 min to complete this activity
- Suspend a flipchart against the chalkboard and invite learners to write answers they have without repeating what others have written
- Invite other learners to give other nutrients that they know: One by one

For activity (3.2.B), student's book S6,

- Give the activity (3.2.B) to each learner
- Give to students this book or other relevant resources
- Give 10 min to the class in order to complete the activity (3.2.B)
- Divide the chalkboard into three parts
- Invite 3 learners to write the answers found in their groups on the board and at the same time so that copy from each other
- Ask the students of other groups to comment on the answers given by the five groups
- Guide learners to find conclusion about the components of a fertiliser.

Answers for activity (3.2.A): Answers will depend on the information they have. During the presentation, remember to take notes on some key points (correct ones and wrong ones) that are going to guide you in the next step

- Ask members of other groups to give their comments on the presentations.
- Based on learners' ideas, guide learners to find the conclusion. Here, you need to emphasize on the components of fertilisers.

Answers for activity (3.2.B): Refer to components of fertilisers in student book.

Answers to Checking up 3.2

1. When it was observed that certain nutrients in the soil are lacking, because they are highly consumed by plants for their growth.
2. (i) P
(ii) K
3. If fertiliser is labelled 13-13-13, it means that the fertiliser contains 13% by mass N, 13% by mass P_2O_5 and 13% by mass K_2O .

Lesson 3: The manufacture of fertilizers

a. Prerequisite knowledge and skills

Students will learn better the manufacture of fertilisers if they have an understanding on preparation of inorganic salts.

b. Teaching resources:

- Books
- Internet
- Samples of inorganic fertilisers in their containers
- Crops of different types (tubers, leguminous plants, cereals)

c. Learning activities:

As a guide, the teacher is expected to guide learners through the following steps:

Activity 3.3

For activity (3.3.1),

- Give the activity to learner in pairs (or in groups of 3 to 4 students)
- Give 15 min to the class in order to complete the activity (3.3.1)
- Select five students to write the reaction(s) got for each compound
- Ask learners to comment on the answers given by the other groups
- Do the harmonization

For activity (3.3.2 & 3.3.3), student's book S6,

- Put your students in groups of 4
- Give to students this book or other relevant resources
- Give to your students, 25 minutes to read and analyse the content about the manufacture of the following fertilisers: Ammonium sulphate, potassium sulphate, ammonium nitrate, urea, and phosphates

- Invite four members from four groups to present the findings of their groups.
- Ask members of other groups to give their comments on the presentations.
- Based on learners' work, guide them to draw important conclusions. Here, you need to emphasize on the manufacture of fertilisers

The expected answer for activity (3.3.3) is **methane** from Kivu lake (methane can be an important source for **urea**)

Answers to Checking up 3.3

1. Complete the following table

Fertiliser	Raw materials	Reaction(s) involved
Ammonium sulphate	$\text{NH}_3, \text{H}_2\text{SO}_4$	Refer to student's book, S6
Urea, or carbamide ($\text{H}_2\text{N-CO-NH}_2$)	$\text{H}_2, \text{CO}, \text{NH}_3$	Refer to student's book, S6

2. Methane gas is used to produce urea

Lesson 4: Advantages/disadvantages of the use of organic and inorganic fertilizers.

a. Prerequisite knowledge and skills:

Students will learn better the content about the advantages and disadvantages of the use of organic and inorganic fertilisers if they have an understanding on effective ways of waste management; water and its composition; Air composition and pollution. Students should also have a good understanding on debate.

b. Teaching resources:

This book or other relevant books; Internet; Manilla papers; Markers; Chalk and Chalkboard, Projector

c. Learning activities:

Methodological steps and correction of activity

The teacher is expected to guide learners through the following steps: Activity 3.4

For the activity (3.4), student's book S6,

Seven days before the presentation.

- Form groups of four students for each: some groups are called opposers and others are called proposers
- Give the topic: **The use of fertilizer is a harm to humanity**
- Provide the resources (or ways to have access to access to resources) about the topic

The day of debate

- Choose two groups at random: Group which opposes and a group which proposes the topic
- Conduct the debate in class
- Choose randomly the chair person, time keeper, judges, secretaries to note some key points about the topic and mistakes in content, language doctor to correct the mistakes of language.
- Take notes on some key points (correct ones and wrong ones) that are going to guide you in the next step

Based on the findings from the debate, guide learners to give a conclusion about advantages/disadvantages of the use of organic and inorganic fertilisers

C Answers to Checking up 3.4

(1)-It is a gas and therefore less easy to store(It is stored in form of ammonium salts)

-It is basic, so it can affect the natural pH of the soil (for short term it makes the soil basic but with time, it will make the soil acidic as it is transformed into nitrates)

-Ammonia easily evaporates if directly applied to the soil because it is a gas at room temperature

For (2) and (3) refer to student's book, S6

Lesson 5: Dangers of the use of substandard fertilizers

a. Prerequisites/Revision/Introduction:

Students will learn better if they an understanding on effective ways of waste management, water and its composition, Air composition and pollution, Waste materials.

b. Teaching resources:

Books, Internet, Samples of inorganic fertilisers in their sacs (containers)

c. Learning activities:

As a guide, the teacher is expected to guide learners through the following steps:

Activity 3.5

For the activity (3.5), student's book S6,

- Put your students in groups of 4
- Give to students this book or other relevant resources
- Give 10 minutes to the groups in order to read and analyze the content about the dangers of substandard fertilisers.
- Invite 3 members from three groups (or more depending on the content presented and time) to present their findings.
- Ask members of other groups to give their comments and add on.
- Based on learners' findings, you guide learners to find the conclusion. Here, you need to emphasize on the dangers of substandard fertilisers by providing more examples from students book and from activity 3.4(debate).

Checking up3.5

- 1.The dangers can be found from student's book and the ideas got from debate in activity 3.4
2. See student's book

Practical Activity

Determination of the percentage by mass of N in $(\text{NH}_4)_2\text{SO}_4$

You are provided with the following:

- 1. A Solution** prepared by mixing 5.0 g of a sample of ammonium sulphate fertiliser which were warmed with sodium hydroxide and the ammonia evolved was absorbed in 100 cm³ of 0.5 mol dm⁻³ sulphuric acid
- 2. 1M sodium hydroxide**

PROCEDURE

Fill the burette with solution of sodium hydroxide

Pipette 20 cm³ of solutions of the prepared solution in (A), in conical flask. Add 2-3 drops of methyl orange indicator.

- Titrate this solution with sodium hydroxide from the burette until the indicator changes colour (indicator changes from **pink** to **yellow**).
- Record the results in the table.

V Volume of pipette used: **20.0**..... cm³

Titration number	1	2	3
Final burette reading (cm ³)			
Initial burette reading (cm ³)			
Volume of sodium hydroxide used (cm ³)			

Questions

- Title values:
- Calculate the average volume of sodium hydroxide used: **6.20 ml**
- Write the equation for the reaction between

(a) Sodium hydroxide and sulphuric acid:

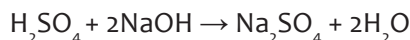

(b) Ammonium sulphate and sodium hydroxide

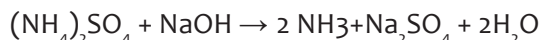

(c) Ammonia and Sulphuric acid

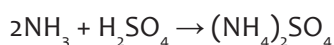

4. Calculate

(a) Moles of base that reacted with excess sulphuric acid:

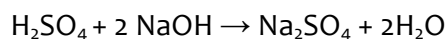

$$M \times V = 1 \times 6.2 \times 10^{-3} = \mathbf{6.2 \times 10^{-3} \text{ moles}}$$

(b) Moles of excess sulphuric acid

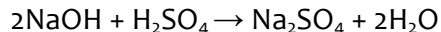

Mole ratio between NaOH and H_2SO_4 is 2:1

$$\text{moles of NaOH} \rightarrow \frac{1 \text{ mol of H}_2\text{SO}_4}{2}$$

$$6.2 \times 10^{-3} \rightarrow \frac{1 \text{ mol of H}_2\text{SO}_4}{2} \times 6.2 \times 10^{-3} = \mathbf{3.1 \times 10^{-3} \text{ moles}}$$

(c) Total moles of the added sulphuric acid

$$n = M \times V = 0.5 \times 20 \times 10^{-3} = \mathbf{10^{-2} \text{ moles}}$$

(d) Moles of sulphuric acid that reacted with ammonia

Total moles of H_2SO_4 – moles H_2SO_4 Excess

$$10^{-2} - 3.1 \times 10^{-3} = 0.0069 \text{ moles}$$

(e) Mole of ammonia produced by the fertilizer

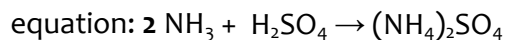

$$\text{according to the mole ratio, } n \text{ NH}_3 = 2 \times 0.0069 = \mathbf{0.0138 \text{ moles}}$$

(f) Mole of $(\text{NH}_4)_2\text{SO}_4$ in the fertilizer

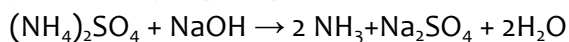

$$2 \text{ moles of NH}_3 \text{ are produced by } \frac{1 \text{ mole of } (\text{NH}_4)_2\text{SO}_4}{2}$$

$$0.138 \text{ moles} \rightarrow \frac{1 \text{ mole of } (\text{NH}_4)_2\text{SO}_4}{2} \times 0.0138 = \mathbf{0.0069 \text{ moles}} \text{ of } (\text{NH}_4)_2\text{SO}_4 \text{ in } 20\text{cm}^3$$

$$\begin{aligned} \text{number of moles of } (\text{NH}_4)_2\text{SO}_4 \text{ in original sample} &= (0.0069 \text{ moles} \times 100) / 20 \\ &= 0.0345 \text{ moles} \end{aligned}$$

(g) Mass of $(\text{NH}_4)_2\text{SO}_4$

$$m = n \times M_m = 0.0345 \times 132 = 4.554\text{g}$$

(h) Mass of N in the fertilizer

$$M_m (\text{NH}_4)_2\text{SO}_4 = 132 \text{ g/mol}$$

Mass of two moles of N = 28

$$\begin{aligned} (\text{NH}_4)_2\text{SO}_4 &\rightarrow \frac{28 \text{ g of N}}{132} \\ 4.554\text{g} &\rightarrow (28 \text{ g of N} \times 4.554) / 132 = 0.966\text{g} \end{aligned}$$

(i) Percentage of N in the fertilizer

$$(0.966\text{g} \times 100) / 5 = 19.32\%$$

3.6. Summary of the unit

There are two main types of fertilizers: organic fertilisers and inorganic fertilisers. Plants need both organic and inorganic fertilisers because soils do not have all types of nutrients in a proper proportion which can fit all plants.

Plants need three types of nutrients: major nutrients, secondary nutrients, and micronutrients. The major nutrients usually are lacking from the soil because plants consume these nutrients in large amounts for their growth and survival. That is another reason inorganic fertilisers have to be supplied to the soil.

Secondary nutrients because these nutrients are enough in the soil, so fertilization is not always needed. Micronutrients are those elements essential for plant growth which are needed but in only very small (micro) quantities.

Using fertilizers is important in order to increase the crop production so that Rwanda can meet the demand in terms of food. However, care should be taken in using fertilisers so that the dangers (acidification of the soil or making them basic; burning of crops; eutrophication) arising from their use are minimized. Special a dangers of the use of substandard fertilizers and there we saw that the use of substandard fertilizes may lead to many risks such as increase of eutrophication, burning of crops

3.7. Additional Information for teachers

Note: The content below is for the teacher only. It is beyond the curriculum, beyond what learners have to learn.

Soil Management

Soil management is an integral part of land management and may focus on differences in soil types and soil characteristics to define specific interventions that are aimed to enhance the soil quality for the land use selected.

Soil management practices that are needed to protect and conserve the soil:

- Soils should be set aside(not be exploited for some time) so that nutrients are developed again
- Avoid repeated use of a fertilizer
- Use fertilizers to support nutrients of soils
- Test the soils in order to cultivate plants appropriate to a given land and in order to put appropriate chemical fertilizers in a soil.
- Standardization of fertilizers by Rwanda standard board
- Use of chemical fertilizers with coatings so that nutrients are released slowly.
- Controlling traffic on the soil surface helps to reduce soil compaction, which can reduce aeration and water infiltration.
- Cover crops keep the soil anchored and covered in off-seasons so that the soil is not eroded by wind and rain.
- Crop rotations for row crops alternate high-residue crops with lower-residue crops to increase the amount of plant material left on the surface of the soil during the year to protect the soil from erosion.
- Nutrient management can help to improve the fertility of the soil and the amount of organic matter content, which improves soil structure and function.
- Tillage is the breaking of soil, such as with a plough or harrow, to control weeds. Reduced-tillage or no-till operations limit the amount of soil disturbance while cultivating a new crop, and help to maintain plant residues on the surface of the soil for erosion protection and water retention.
- Provide the facilities for watering. Example: water dams for irrigation

Advantages of soil management

- Maintain soil fertility
- Restore soil fertility
- Make the agricultural process an economic one
- Help increase yield
- Reduce soil erosion

Correction soil acidity and Soil basicity

- Correcting very acidic soil usually involves working lime into the soil a few weeks before planting
- Correcting alkaline soil involves the addition of gypsum

How plants utilise some fertilisers

Example: Ammonium sulphate, $(\text{NH}_4)_2\text{SO}_4$

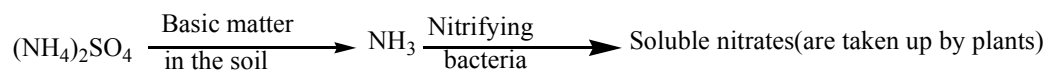

3.8. End unit assessment

Learning and assessment standards:

State the major components of fertilizers and explain their importance and dangers associated with using them, evaluating the usefulness and relevance of information from different sources

A. MULTIPLE CHOICE QUESTIONS

- (c) Nitrogen fertilisers
- (b) Eutrophication
- (a) Nitrous oxide
- (d) Both (a) and (c)

B. OPEN QUESTIONS

5. The best source of nitrogen in the compounds

Compound	Mm	Mass of N/g	%Element
NaNO_3	85	14 g	$\frac{14}{85} \times 100\% = 16.5\%$
NH_4NO_3	80	28 g	$\frac{28}{80} \times 100\% = 35\%$
$(\text{NH}_4)_2\text{SO}_4$	132	28 g	$\frac{28}{132} \times 100\% = 21.2\%$
$\text{CO}(\text{NH}_2)_2$	60	28 g	$\frac{28}{60} \times 100\% = 46.7\%$

Therefore urea ($\text{CH}_4\text{N}_2\text{O}$) is the best source of nitrogen.

6. (a) -Reduction of cost of transport of raw materials (example: ammonia)
-Nitric acid can be produced on the same site (by Ostwald process), and that can reduce also the cost for transport

(b)- Recycling the raw materials which have been not used in the process

-Use of catalytic converters which can convert harmful gases to safe gases (nitrogen monoxide produced in Ostwald process can be converted into nitrogen

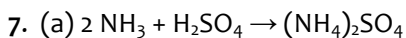

(b) Ammonia is basic

(c) Mm $(\text{NH}_4)_2\text{SO}_4 = 132 \text{g/mol}$

Mm $\text{NH}_3 = 17 \text{g/mol}$

$$34 \text{g of ammonia} \rightarrow \frac{132 \text{g of } (\text{NH}_4)_2\text{SO}_4}{34} \times 100 = 388.24 \text{g of } (\text{NH}_4)_2\text{SO}_4$$

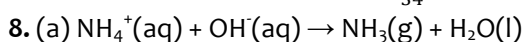

(b) A test tube containing concentrated ammonia is approached to a test tube containing concentrated hydrochloric acid

Observation: Dense white fumes of NH_4Cl are produced

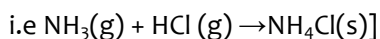

9. (a) fertilizer provides nutrients to plants because the soil may have insufficient nutrients for plant growth or the soil may be in lack of the nutrients that the fertilizer provides.

(b) The processes illustrated by the flow diagram above are that of inorganic fertilizer. Because ammonium nitrates and ammonium sulphates are inorganic compounds and they cannot be found anywhere in nature.

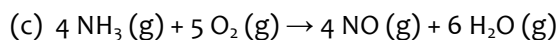

The mixture is passed over platinum-rhodium wire gauze catalysts kept at about 700°C and 9 atmospheres pressure (high temperatures and pressures).

(d) Catalytic oxidation of ammonia

(e) D. HNO_3

(f) C: $(\text{NH}_4)_2\text{SO}_4$ D: NH_4NO_3

10. (a) Reduction of cost of transport of raw materials (example: ammonia) Nitric acid can be produced on the same site (by Ostwald process), and that can reduce also the cost for transport

(b) -Recycling the raw materials which have been not used in the process

-Use of catalytic converters which can convert harmful gases to safe gases (nitrogen monoxide produced in Ostwald process can be converted into nitrogen

[11] and [12] Refer to student's book about the advantages/disadvantages of the use

of organic and inorganic fertilisers and about the dangers of the use of substandard fertilisers,3.9. Additional activities

Remedial activity

1.The production of nitric acid is very important in the manufacture of fertilisers. Look at the diagram below, which shows part of the fertiliser production process, and then answer the questions that follow.

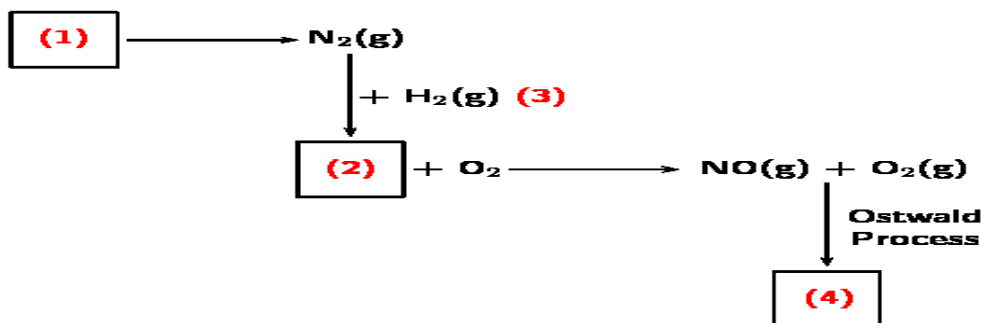

- Name the process at (1).
- Name the gas at (2).
- Name the process at (3) that produces gas (2).
- Name the immediate product at (4).
- Name the final product of the Ostwald process (product (4))
- Name two fertilisers that can be produced from nitric acid.

Answers:

- Fractional distillation of air
 - Ammonia
 - Haber process
 - Nitrogen dioxide
 - Nitric acid
 - Nitro phosphate or ammonium nitrate.
2. A cultivator needs to cultivate potatoes and he goes to agrotech to buy NPK fertiliser whose label is 17-00-00.
- What is the meaning of this label?
 - Is the fertilizer convenient for the good harvest of the potatoes?
 - Which parts of the plant will be more developed?
 - Give an example of type of crop for which the fertiliser provided can be convenient.

Answer:

- a. It means that the fertiliser contains 17% by mass N, 0% by mass P_2O_5 and 0% by mass K_2O .
- b. No, because there will be high development of leaves and not roots.
- c. Leaves.
- d. Corns during in their early time with the development of leaves

Consolidation activity

Sulphuric acid is used in making fertilizers. What volume of ammonia gas will be required to make 25 kg of ammonium sulphate? (N=14, H=1, S=32, O=16.0 and molar gas volume at r.t.p = 24.0 dm³)

Answer:

Mm NH_3 = 17g, 2 moles of NH_3 = 34g

Mm $(NH_4)_2SO_4(s)$ = 132 g/mol

Mm NH_3 = 17g, 2 moles of NH_3 = 34g

Mm $(NH_4)_2SO_4(s)$ = 132 g/mol

$132 \text{ g } (NH_4)_2SO_4 \rightarrow \frac{34 \text{ g of ammonia}}{132}$

$25\,000 \text{ g} \rightarrow \frac{34 \text{ g of ammonia}}{132} \times 25\,000 = 6439.39 \text{ g}$

Mass of ammonia required for preparing 25 000g of $(NH_4)_2SO_4$ is **6439.39 g**

The equation between ammonia and sulphuric acid



From the equation above

2 moles of $NH_3 \rightarrow 48 \text{ dm}^3$ of NH_3 at r.t.p because 1 moles of each gas has a volume of 24 dm³ room temperature and pressure (r.t.p).

$34 \text{ g of } NH_3 \rightarrow \frac{48 \text{ dm}^3}{34}$ of $(NH_4)_2SO_4$

$6439.39 \text{ g} \rightarrow \frac{48 \text{ dm}^3}{34} \times 6439.39 = 9090.9 \text{ dm}^3$ of NH_3 are required to prepare 25 000 g of $(NH_4)_2SO_4$

Extended activity

A fertilizer contains ammonium sulphate sample of 0.500g of fertilizer was warmed with sodium hydroxide solution. The ammonia evolved was absorbed in 100cm³ of 0.100mol dm⁻³ hydrochloric acid. The excess hydrochloric acid required 55.9cm³ of 0.1M sodium hydroxide for neutralization. Calculate the percentage of ammonium sulphate in the sample

Answer: The equation for the reaction between

Sodium hydroxide and sulphuric acid:

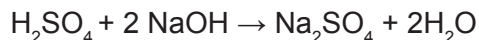

Ammonium sulphate and sodium hydroxide

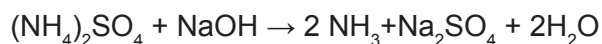

Ammonia and hydrochloric acid

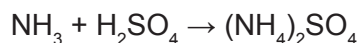

n_{NaOH} which reacted with excess sulphuric acid

$$= 55.9 \times 10^{-3} \times 0.1 = 5.59 \times 10^{-3} \text{ moles } n_{\text{HCl}} = 5.59 \times 10^{-3} \text{ moles}$$

$$\text{Total moles of HCl} = 100 \times 10^{-3} \times 0.1 = 0.01 \text{ moles}$$

$$\text{moles of HCl that reacted} = 0.01 - 5.59 \times 10^{-3} = 4.41 \times 10^{-3} \text{ moles}$$

$$n_{\text{NH}_3} = 4.41 \times 10^{-3} \text{ moles}$$

$$2 \text{ moles of } \text{NH}_3 \rightarrow \frac{1 \text{ mole of } (\text{NH}_4)_2\text{SO}_4}{2} \times 4.41 \times 10^{-3} = 2.205 \times 10^{-3} \text{ moles}$$

$$\text{The number of moles of } (\text{NH}_4)_2\text{SO}_4 = 2.205 \times 10^{-3} \text{ moles}$$

$$\text{Mass of } (\text{NH}_4)_2\text{SO}_4 = n \times M_m = 2.205 \times 10^{-3} \times 132 = 0.29106 \text{ g}$$

$$\% \text{ by mass } (\text{NH}_4)_2\text{SO}_4 = \frac{0.29106 \text{ g}}{0.5} \times 100\% = 58.215\%$$

UNIT 4: BENZENE

4

4.1. Key unit competence:

To be able to relate the chemistry and uses of benzene to its nature and structure.

4.2. Prerequisite knowledge and skills

Students will learn benzene better if they have understanding on: structures of hydrocarbons (both saturated and unsaturated), their preparation methods, their physical and chemical properties and their uses; covered in senior five unit 2, 3 and 4.

4.3. Cross-cutting issues to be addressed

Peace and Values Education

Benzene's structure shows that benzene is expected to be a cyclic alkene with three double bonds. It can be also considered to be isomeric with aliphatic alkynes (from isomers of its molecular formula, C_6H_6). However it does not share the majority of its properties with these hydrocarbons. This can be related to relationship in human beings. People share a lot of characters (things) in common but remember that everyone is unique in certain aspects. Some of these aspects are of good quality and can contribute to the development of the country. When a student fails to cope well with his/her friends he/she may forget his/her uniqueness, quality, target, concentration ... and thus fail to contribute to the development of the country

There is a serious issue of peer pressure and bandwagon (ikigare) in youth. When introducing this unit, it would be an opportunity to guide learners on making decisions in their relationships. Help learners to:

- Understand that relationship is very important. To be successful in life, they have to work together with others to share their qualities and experiences. But they have to choose good friends who will not mislead them.
- Understand that in choosing friends they have to be careful and make sure they make good friends who will support them to achieve their future goals.
- Reflect on their educational goals, the type of friends they have and their characters.
- Assess if the friends they have are likely to help them achieve their future goals or destroy their future.
- Make appropriate decisions, especially when it comes to their individual plans

where they are not guided by teachers or parents.

- f. Maintain the good qualities they have in particular and develop them if possible rather than hiding them in favour of their colleagues bad opinions.

This can be done in a short whole class discussion about the structure of benzene which prevents it from reacting as alkenes for instance. It may be a good entry point for the chemistry teacher to confront the individual students who need advise on relationship matter.

This can be addressed to students just after the introductory activity and when teaching the stability of benzene.

Environment and sustainability

Benzene is highly toxic and so pollutes environment when introduced into it. Its sources include natural and artificial. Young people should be addressed about this issue so that they can avoid to expose themselves to activities/actions that release benzene into the environment such as: smoking, petroleum stations, ...

This will help them to understand the importance of sustainability as they grow up and become responsible for the world around them.

This cross-cutting issue can be addressed after teaching physical properties, uses and toxicity of benzene (**unit 4, section 4.2**).

Inclusive education

This unit requires learners to carry out a lot of researches to be able to understand first, then share and discuss on things like structure of benzene, its stability, and so on. This may be challenging to students with special educational needs especially slow learners. However, as teacher you can organise your class and use different strategies to help all learners understand well. Some of the strategies to be used are provided below:

- Be patient! If you find that the student takes longer than others to learn or to do an activity, allow more time.
- Do activities together with the student.
- Gradually give the student less help.
- Let the student do the activity with his colleagues and encourage them to help each other.
- Divide the activity into small achievable steps.
- Remember to praise and say 'Well done' when the student learns something new or makes a strong effort.

4.4. Guidance on the introductory activity

Benzene is a hydrocarbon as it is made up by hydrogen and carbon atoms only. So, to introduce it to the students can be made simple by starting with hydrocarbons as they studied them in senior five. This is a guidance of how you can help your learners enter in the unit with open mindset about benzene.

- Put your students in groups of 3-4 (or even 5 depending on the size of your class)
- Provide them with books or worksheets with the introductory activity, unit 4 from student's book S6.
- Give them time between 20 and 25 minutes to read, analyze, interpret and discuss about the activity. Here they have to cover the whole activity!
- Divide the chalkboard into two or three parts. In the next step you have to start with instruction number 1 (given as question 1) then number 2 will follow.

Instruction number one (or question 1)

Call five members from different groups (at the same time) to write the five molecular formulae in question 1. Here, each student writes his/her formula.

Ask other members (randomly) to give their inputs about what their colleagues wrote on the chalkboard (here they can confirm what is written or propose other answers).

The expected answers are the following:

- C_6H_{14}
- C_6H_{12}
- C_6H_{10}
- C_6H_8
- C_6H_6

Instruction number one (or question 2 and 3)

- Ask questions randomly to know your students' understanding about the description given on each question and write the possible structures (not necessarily all, 2 or 3 are enough).
- Ask other students (randomly) to give also their inputs about what their colleagues are suggesting on the chalkboard (here they can confirm what is written or propose other answers). Don't worry if they fail on some points especially those involving benzene's properties and structure! In this case, it is not necessary to give them the right answer because they will understand them and be able to do them through this unit. So, you can leave them with that curiosity!

The expected answers are the following:

2. a) C_6H_{12} ; C_6H_{10} ; C_6H_8 . Some structures of C_6H_{12} are shown below.

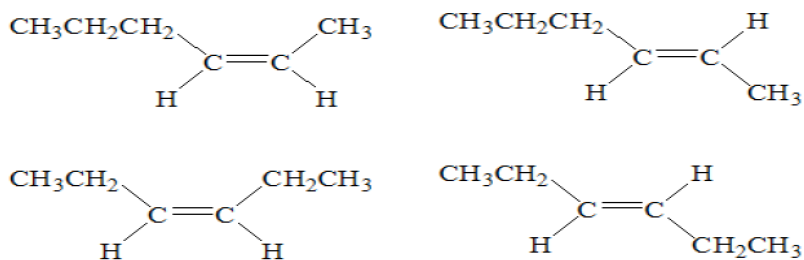

Some structures of C_6H_{10}

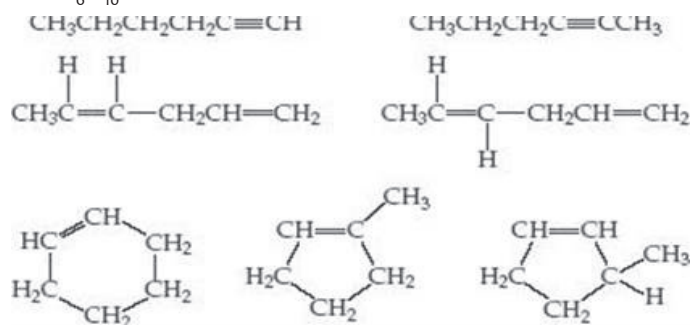

Some structures of C_6H_8

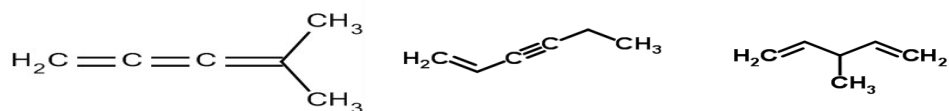

b) C_6H_{14} and structures of C_6H_{12} that are cyclic.

Some structures of C_6H_{14}

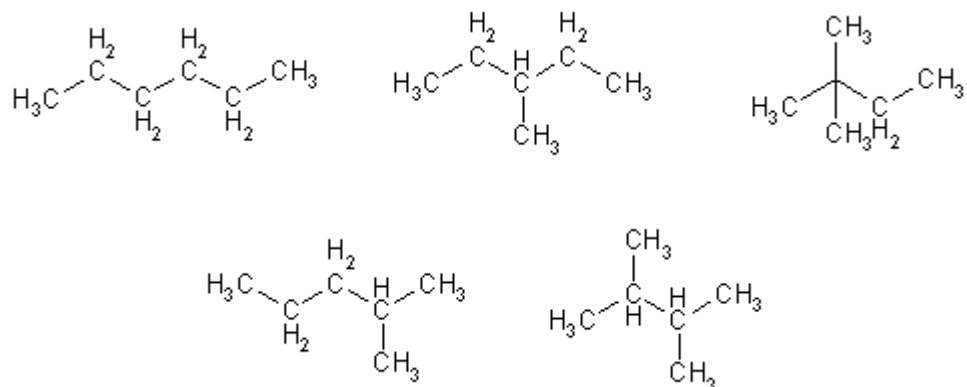

Some cyclic structures of C_6H_{12}

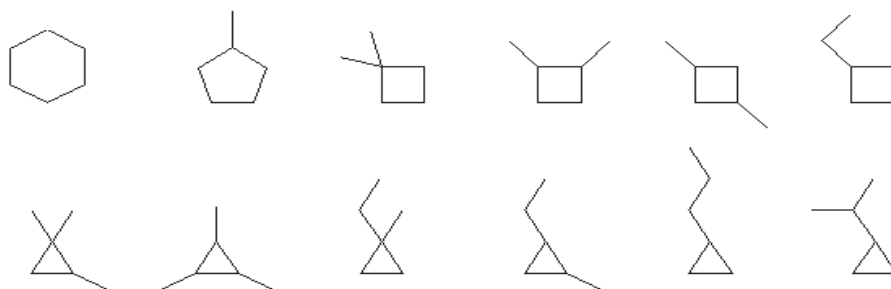

c) C_6H_6

Structures of C_6H_6

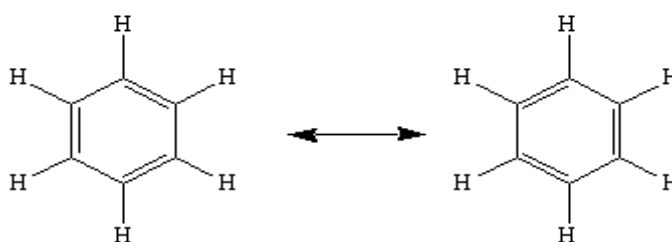

The resonance structures for benzene

d) As in c) above

e) C_6H_{10} (hex-1-yne + its chain isomers) and C_6H_8 (with a terminal triple bond)

Structure of hex-1-yne:

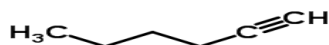

Structure of C_6H_8

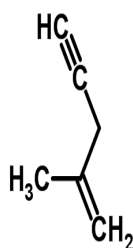

3) Benzene does not decolourise both solutions, due to its stable structure in which pi-electrons are delocalised. Or due to the resonance of its double bonds.

4.5. List of lessons

#	Lesson title	Learning objectives	Number of periods
---	--------------	---------------------	-------------------

1	Introductory activity	Relate benzene to other hydrocarbons	1
2	Structure of benzene	Draw the structural/displayed and skeletal formulae of benzene.	2
3	Physical properties, uses and toxicity of benzene	<ul style="list-style-type: none"> • State the physical properties of benzene. • Describe the uses of benzene. 	1
4	Preparation of benzene	Outline the preparations of benzene.	1
5	Chemical stability of benzene	Relate the conditions for reactions of benzene to its chemical stability	1
6	Reactions of benzene	Describe the chemical properties of benzene State the conditions required for different reactions. Illustrate the mechanism of electrophilic substitutions on benzene	4
7	Nomenclature and positional isomerism in derivatives of benzene	Name aromatic compounds	2
8	Summative assessment		2

Lesson 1: Structure of benzene

a. Prerequisites/Revision/Introduction:

Students will learn better the structure of benzene if they have knowledge on molecular and structural formulae of different hydrocarbons (covered in senior five unit 1 to 3); bond angles, bond length and resonance (covered in senior four unit 4)

b. Teaching resources

Use worksheets or books; projectors and/or chalkboard.

c. Learning activities

Before teaching this topic, remember that this is the first time the student are going to learn something about benzene! So, you need to prepare well by checking all the documents that will help them to understand the structure of benzene by themselves.

Methodological steps:

As a facilitator, you are expected to guide learners to learn by doing activity 4.1, as described below:

Activity 4.1, student book S6

Preparations before teaching about the structure of benzene and the next points:

- Take one day before conducting this activity in your classroom to read various books (such as OCR Chemistry A2, Advanced organic chemistry, etc) or research on internet about the history of development of benzene.
- From the above task, you will select important sources to be utilized by your students.

On the teaching day (in classroom):

- Group your students in pairs (or groups of 3 or more depending on the size of your classroom) and provide them with resources to be used while carrying out their research.
- Give them time for research (10-15 minutes) for discussion in their respective groups
- Call two or 3 (or more depending on your time) groups to present their findings. During the presentation, remember to take notes on some key points (correct ones and wrong ones) that are going to guide you in the next step
- Ask members of other groups to give their comments/ inputs if any.
- Based on learners' production, through questioning, guide them to draw important conclusions. Here, you need to focus on resonance in Kekule's structure

After carrying out research, students should present one or some (or even all) of the following:

- Benzene's structure by drawing its formula for example,
- The name of the one who discovered it, i.e, *Michael FARADAY*, or (*Kékulé*) *Friedrich August Kékulé Von Stradonitz*,
- How it is prepared from ethyne
- And so on.

If possible you can end up with checking up 4.1, student's book S6 or give it to them as a homework.

Answers to Checking up 4.1

This checking can be performed better if it is done in pairs, or given to individual students as a homework.

Answers:

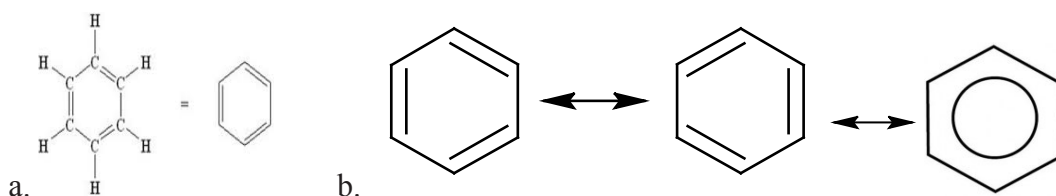

The following structure is a benzene ring. Its chemical formula is C_6H_6 :

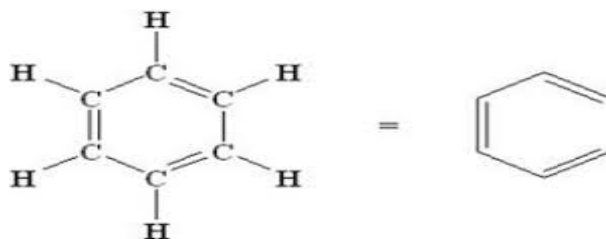

2. The following structure is a cyclohexane ring. Its chemical formula is C_6H_{12} .

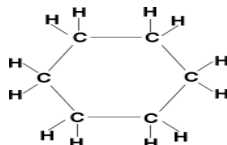

Some major differences in their structure include:

- Benzene is an aromatic compound but cyclohexane is not aromatic.
- Benzene is an unsaturated molecule, but cyclohexane is saturated.
- Carbon atoms in the benzene ring have sp^2 hybridization where carbon atoms in the cyclohexane have sp^3 hybridization.
- Benzene has a planar structure whereas cyclohexane has chair conformations.
- Benzene has alternate double bonds and alternate single bonds while cyclohexane has only single bonds.

3. Benzene has the chemical formula of C_6H_6 where each Carbon atom is bonded to two other Carbon atoms and a single Hydrogen atom. The 4th bond pair of electrons from each Carbon atom is delocalised, creating a delocalised cloud of electrons above and below the plane. Benzene is a hexagonal ring in shape with bond angles of 120degrees between Carbon atoms. All the bond lengths in Benzene are equal. Because of the system of delocalised electrons Benzene is also far more energetically stable than it should be; its extra stability is known as its delocalisation energy. Because of its increased stability Benzene does not readily undergo addition reactions; instead it undergoes substitution reactions whereby a hydrogen atom is replaced by another atom or group of atoms.

Lesson 2: Physical properties, uses and toxicity of benzene

a. Prerequisites/Revision/Introduction:

Students will learn better the physical properties, uses and toxicity of benzene if they have knowledge on main points that govern the physical properties (such as melting and boiling points, density, state at room temperature, ...) of different compounds (covered in most units of senior four and five) and environmental pollution

b. Teaching resources

Use worksheets or books; projectors and/or chalkboard.

c. Learning activities

You can start by asking your students questions about the structure of benzene

Methodological steps:

As a facilitator, you are expected to guide learners to learn by doing activity 4.2, as described below:

Activity 4.2, student book S6

- Ask questions about the previous lesson
- Group your students in pairs (or groups of 3 or more depending on the size of your classroom) and provide them with resources to be used while carrying out their research.
- Give them time for research (5-10 minutes) for discussion in their respective groups
- Call two or 3 (or more depending on your time) groups to present their findings. During the presentation, remember to take notes on some key points (correct ones and wrong ones) that are going to guide you in the next step
- Ask members of other groups to give their comments/ inputs if any.
- Based on learners' production, through questioning, guide them to draw important conclusions. Here, you need to emphasize on the toxicity of benzene.
- The main points talked about when discussing the physical properties any substance are:
 - Physical state at room temperature
 - Appearance (color)
 - Melting point
 - Boiling point
 - Density
- Check the physical properties of benzene in student's book.
- End up with checking up 4.2 on page ..., student's book S6. This can be done randomly in a verbal way.

Answers to Checking up 4.2, student's book S6

1. Carcinogenic means any chemical known to cause cancer in humans.
2. Cigarette smoke contains benzene. Exposure to benzene vapour causes dizziness, unconsciousness, anaemia or leukaemia and eventually cancer. Thus, the main advice here is that everybody should not smoke

Lesson 3: Preparation of benzene

a. Prerequisites/Revision/Introduction:

Students will learn better the chemical reactions of alkanes, especially reforming,

polymerization of alkynes into benzene plus preparation methods of other organic chemistry as covered in senior five.

b. Teaching resources

Use worksheets or books; projectors and/or chalkboard.

c. Learning activities

You can start by asking your students questions about the structure of benzene

Methodological steps:

As a facilitator, you are expected to guide learners to learn by doing activity 4.3, as described below:

Activity 4.3, student book S6

In the first task, in activity 4.3, student's book S6,

- Guide students to revise about the reactions of hydrocarbons given as examples which lead to the formation of benzene.
- for the expected answers Refer to student's book, unit 4, part 4.3.

In the second task (where students have to find out other methods used to prepare benzene)

Put your students in groups of 3-4

Give your students time between 5 and 10 minutes to read and analyze the summary (about the methods of preparation of benzene) in the student book, or any other way (work sheet, projection, books from library, internet, ...) you may have prepared for them.

Call two or 3 (or more depending on your time) groups to present their findings. During the presentation, remember to take notes on some key points (correct ones and wrong ones) that are going to guide you in the next step

- Ask members of other groups to give their comments/ inputs if any.
- Based on learners' production, through questioning, guide them to draw important conclusions. Here, you need to emphasize on the new methods such as the one starting with azo-compounds.

Note: After carrying out research, students should notice by themselves both industrial and laboratory methods used to prepare benzene.

- Give them checking up 4.3, in student's book as homework

Answers to Checking up 4.3, student's book S6

Step 1: thermal decomposition of calcium carbonate



Step 2: heating calcium oxide with coke (at 2000°C) to form calcium dicarbide

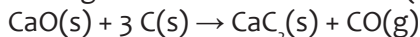

Step 3: dissolving calcium dicarbide in water in presence of acidified copper (II) sulphate to produce acetylene (ethyne)

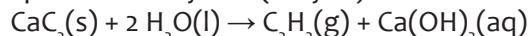

Step 4: heating acetylene with iron catalyst

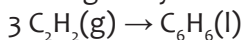

Lesson 4: Chemical stability of benzene

a. Prerequisites/Revision/Introduction:

Refer to lesson one in this unit

b. Teaching resources

Use worksheets or books; projectors and/or chalkboard.

c. Learning activities

You can start by asking your students questions about the structure of benzene

Methodological steps:

As a facilitator, you are expected to guide learners to learn by doing activity 4.4, as described below:

Activity 4.4, in student book S6

- Put your students in groups of 3-4 (or even 5 depending on the size of your class)
- Provide them with books or worksheets with the activity 4.4 from student's book, give them time between 10 and 15 minutes to read, analyze, interpret and discuss about the activity.

- Divide the chalkboard into two or three parts.
- Call the representatives any 2 or 3 groups (at the same time) to present their findings by writing their answers in the provided parts on the chalkboard.
- Ask other groups to consolidate by complementing their colleagues who have presented.
- Guide them to draw important conclusions.

The expected answers are the following:

- The energy needed to produce
 - Six moles of gaseous carbon atoms from C(s): $6 \times (+715 \text{ kJ}) = +4290 \text{ kJ}$
 - Six moles of gaseous hydrogen atoms from H₂(g): $6 \times (+218 \text{ kJ}) = +1308 \text{ kJ}$
- The energy released when
 - Three moles of C-C bonds are formed from gaseous atoms: $3 \times (+346) = +1038 \text{ kJ}$
 - Three moles of C=C bonds are formed from gaseous atoms $3 \times (+610) = +1830 \text{ kJ}$
 - Six moles of C-H bonds are formed from gaseous atoms. $6 \times (+413) = +2478 \text{ kJ}$
- Total enthalpy change in [1]: $4290 + 1308 = +5598 \text{ kJ}$
 Total enthalpy change in [2]: $1038 + 1830 + 2478 = +5346 \text{ kJ}$
 The formation of benzene involves the following reaction

$$6\text{C}(\text{s}) + 3\text{H}_2(\text{g}) \rightarrow \text{C}_6\text{H}_6(\text{l})$$
 Enthalpy change for the reaction = the sum of enthalpy changes in reactants [1] – the sum of enthalpy changes in products [2]
 Enthalpy change of formation of benzene = $+5598 \text{ kJ} - (+5346 \text{ kJ}) = +252 \text{ kJ}$
- $252 - 82 = 170 \text{ kJ}$
 The calculated (theoretical) enthalpy change of benzene is greater than the experimental value by 170 kJ.
- After searching, the students will come up with some or all of the following points:
 - The delocalisation of p-electrons or aromaticity of benzene
 - Resonance of the double bonds in benzene
 - The low reactivity of benzene due to its stability
 - And so on

End up by giving them checking up 4.4 (student's book S6)

Answer to Checking up 4.4, student book S6

The results obtained activity 4.4, suggest that real benzene is more stable than Kekule' structure.

Real benzene is more stable than cyclohexa-1,3,5-triene by 170 kJ. This is due to the resonance of the double bonds in benzene ring.

Lesson 5: Reactions of benzene

a. Prerequisites/Revision/Introduction:

Students will learn better the reactions of benzene if they have knowledge on chemical properties of alkenes, alkanes, halogenoalkanes carbonyl compounds and carboxylic acids (covered in senior five)

b. Teaching resources

Use worksheets or books; projectors and/or chalkboard.

c) Learning activities

You can start by asking your students questions about the structure of benzene

Methodological steps:

As a facilitator, you are expected to guide learners to learn by doing activity 4.5, as described below:

Activity 4.5

- Group your students in pairs (or groups of 3 or more depending on the size of your classroom) and provide them with resources to be used while carrying out their research.
- Give them time for research (15-20 minutes) for discussion in their respective groups
- Call two or 3 (or more depending on your time) groups to present their findings. During the presentation, remember to take notes on some key points (correct ones and wrong ones) that are going to guide you in the next step
- Ask members of other groups to give their comments/ inputs if any.
- Based on learners' production, through questioning, guide them to draw important conclusions. Here, you need to emphasize on the reason why benzene prefers electrophilic substitution reactions to addition and their mechanism.

You need to remember that students fear mechanisms! But try to show that this is simple by using an example on alkylation for instance. All electrophilic substitution reactions follow the same methodology

Step 1: formation of an electrophile

Step 2: the benzene ring attacks the electrophile using one of its pi-electrons (focus on the direction of curly arrow from the species rich in electrons/nucleophile to the electron-deficient species/electrophile).

Step3: deprotonation of benzene

N.B: After research, the students will come up with some or all of the following points:

- To keep its stability, Benzene undergoes substitution reactions rather than addition reactions.
- Electrophiles activate the benzene ring and then replace one or more hydrogen atoms in the ring
- Mechanism for electrophilic substitution reactions (halogenation, nitration, sulphonation, alkylation and acylation)

If possible you can end up with checking up 4.5, student's book S6 or give it to them as a homework

Answers to Checking up 4.5, student's book S6

- Refer to student's book
- Concentrated Nitric acid and concentrated sulphuric acid
- An electrophile is formed during the nitration of benzene
 - ${}^+\text{NO}_2$
 - $\text{H}_2\text{SO}_4 + \text{HNO}_3 \rightarrow \text{HSO}_4^- + \text{H}_2\text{O} + \text{NO}_2^+$
 - Refer to student's book

Lesson 6: Nomenclature and positional isomerism in derivatives of benzene

a. Prerequisites/Revision/Introduction:

Students will learn better the reactions of benzene if they have knowledge on the nomenclature of alkenes, alkanes, halogenoalkanes carbonyl compounds, carboxylic acids and any other organic compounds (covered in senior five)

b. Teaching resources

Use worksheets or books; projectors and/or chalkboard.

c. Learning activities

You can start by asking your students questions about the nomenclature of any organic compounds including benzene derivatives

Methodological steps:

As a facilitator, you are expected to guide learners to learn by doing activity 4.6, as described below:

Activity 4.6, in student book S6

In question 1, in activity 4.6 (a), student's book S6,

- Guide students to revise about the nomenclature of compounds in general by asking them randomly. The molecules given in d) and e) are aromatic compounds. Ask them to draw their possible structures first, and name each structure drawn.
- The following are the expected answers
 - a. $\text{CH}_3\text{CH}_2\text{CH}(\text{CH}_3)\text{CH}_3$: Methylbutane
 - b. $\text{ClCH}_2\text{CH}_2\text{CHOHCH}_3$: 4-chlorobutan-2-ol
 - c. $\text{CH}_3\text{CH}(\text{C}_6\text{H}_5)\text{CH}_2\text{CH}_2\text{CH}_3$: 2-phenylpentane
 - d. $\text{C}_6\text{H}_5\text{NO}_2$: Nitrobenzene
 - e. $\text{C}_6\text{H}_4\text{ClBr}$: 1-Bromo-2-chlorobenzene or 1-bromo-3-chlorobenzene or 1-bromo-4-chlorobenzene

In the task 2:

- Put your students in groups of 3-4
- Give your students time between 10 and 15 minutes to read and analyze the content (about the rules of naming aromatic compounds) you have prepared for them on worksheets or in the student's book S6
- Call two or 3 (or more depending on your time) groups to present their findings.

During the presentation, remember to take notes on some key points (correct ones and wrong ones) that are going to guide you in the next step

- Ask members of other groups to give their comments/ inputs if any.
- Based on learners' production, through questioning, guide them to draw important conclusions. Here, you need to emphasize on the positional isomers in disubstituted benzene derivatives.
- After research, the students will come up with some or all of the following points:
 - Monosubstituted benzene derivatives are named by starting with the substituent's name followed by benzene. For disubstituted benzene derivatives, the positions of the substituents in relation to one another is revealed since there exhibit positional isomers
 - And so on.

Give them checking up 4.6, in student's book as evaluation

Answers to Checking up 4.6, student's book S6

1. The three structural isomers are 1,2-dibromobenzene (o-dibromobenzene); 1,3-dibromobenzene (m-dibromobenzene) and 1,4-dibromobenzene (p-dibromobenzene)



2. Three isomers of nitrophenol (ortho, meta and para)

4.6. Summary of the unit

Benzene is a *colourless volatile liquid* with an aromatic (pleasant) smell. It is found in crude oil and is a major part of gasoline. It is used to make plastics, resins, synthetic fibers, rubber, lubricants, dyes, detergents, drugs and pesticides. Benzene is **highly toxic** and is said to be *carcinogen*.

Benzene is obtained on industrial scale by fractional distillation of petroleum oil followed by catalytic reforming.

The delocalization of pi-electrons in benzene molecule provides it extra stability which is known as 'aromaticity'. Due to aromaticity in the molecule, benzene is more stable compared to aliphatic alkenes and does not show specific addition reactions of alkenes. This stability is explained on the basis of resonance in the molecule.

To retain its stability, benzene does not undergo electrophilic addition reactions as it is the case for alkenes. Rather, it undergoes electrophilic substitution reactions in presence of a Lewis acid which acts as a halogen carrier to generate an active electrophile.

Benzene derivatives are obtained by replacing one or more hydrogen atoms on benzene ring with other substituent groups. The systematic nomenclature for benzene derivatives involves naming substituent groups and identifying their positions on the ring by numbering the six carbon atoms in one direction. One identifies positional isomers of di-substituted benzene with the prefixes – Ortho, O-substituent groups on adjacent carbons in benzene ring. Meta, m- substituents separated by one carbon atom. Para, p- substituent groups on carbons on opposite sides of ring.

4.7. Additional information for teachers

The presence of substituent group on benzene ring changes something on its identity. The group present on a benzene ring may increase its reactivity (this is the case of ring activators, such as CH_3 -, $-\text{NH}_2$...) or decrease its reactivity (this is the case of ring deactivators, such as $-\text{NO}_2$, $-\text{COOH}$...). The present substituent is also the one to determine the position of the incoming groups during the reactions involving

monosubstituted benzene ring. This information will be given to students in the next unit.

4.8. End unit assessment

Learning and assessment standards:

Apply knowledge of organic chemistry and resonance in inorganic substances to investigate the properties of benzene related to its structure.

Answers to end unit assessment questions

I. MULTIPLE CHOICE QUESTIONS

- | | |
|------|------|
| 1. c | 5. a |
| 2. e | 6. d |
| 3. a | 7. a |
| 4. c | 8. d |

9.

II. OPEN QUESTIONS

- | | |
|--|------------------------------------|
| a. Chlorobenzene | f. m - Chlorobenzaldehyde |
| b. t-Butylbenzene | g. 2 - Chloro -1,4 -dinitrobenzene |
| c. (2-Ethylpentyl)benzene or 2-Ethyl-1-phenylpentane | h. 4 - Bromo- 1,2- dimethylbenzene |
| d. o - Hydroxybenzoic acid | i. 2,6-dibromophenol |
| e. 1,2 - benzene dicarboxylic acid or Phthalic acid | j. 4 -Chloro- 2,5 -dinitrotoluene |

2.

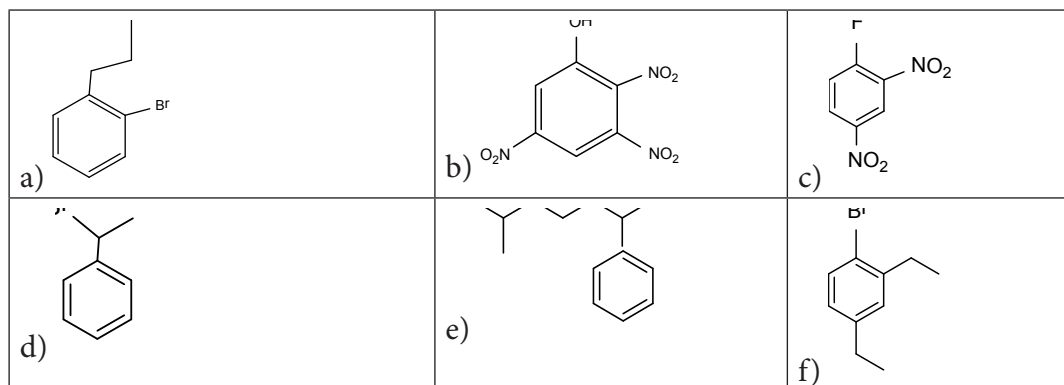

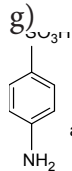
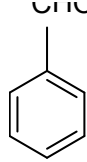
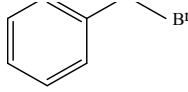
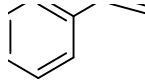
<p>g)</p>  <p>also called (p-aminobenzenesulfonic acid)</p>	<p>h)</p> 	<p>i)</p> 
<p>j)</p> 		

3. Benzene is a planar molecule with the shape of regular hexagon
 - a. Heat of hydrogenation is less than expected
 - b. All C – C – C bond angles are 120 °, all six carbon atoms are sp² hybridized
 - c. All C – C bonds have the same length (139 pm)
4. Conjugated with p orbital on each carbon
 - i. Kekule resonance structures
 - a) Cyclohexane $\Delta H_{hyd} = -118 \text{ kJ/mol}$ (least stable)
 - b) 1,3 - Cyclohexadiene $\Delta H_{hyd} = 2 \times (-118) = -230 \text{ kJ/mol}$
 - c) Benzene $\Delta H_{hyd} = -206 \text{ kJ/mol}$ (most stable)

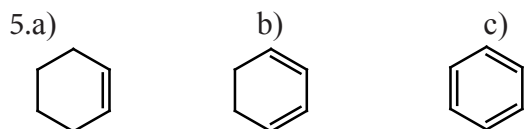

The chemical reactivity of benzene contrasts with that of the alkenes in that substitution reactions occur in preference to addition reactions, as illustrated in the following diagram (some comparable reactions of cyclohexene are shown in the green box).

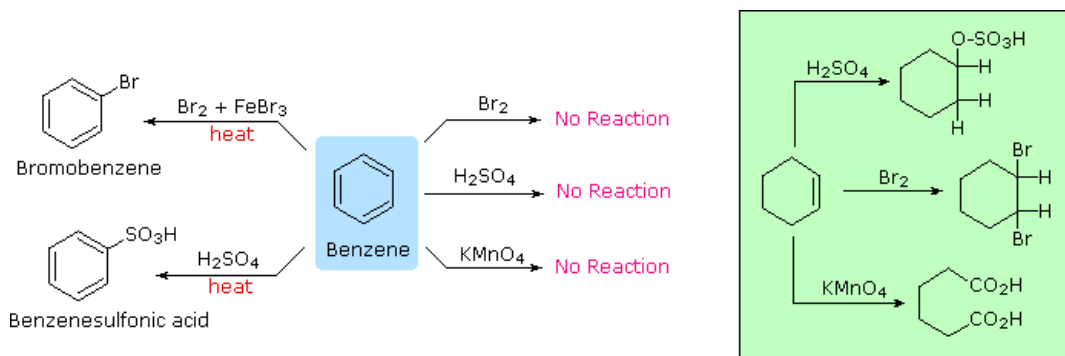

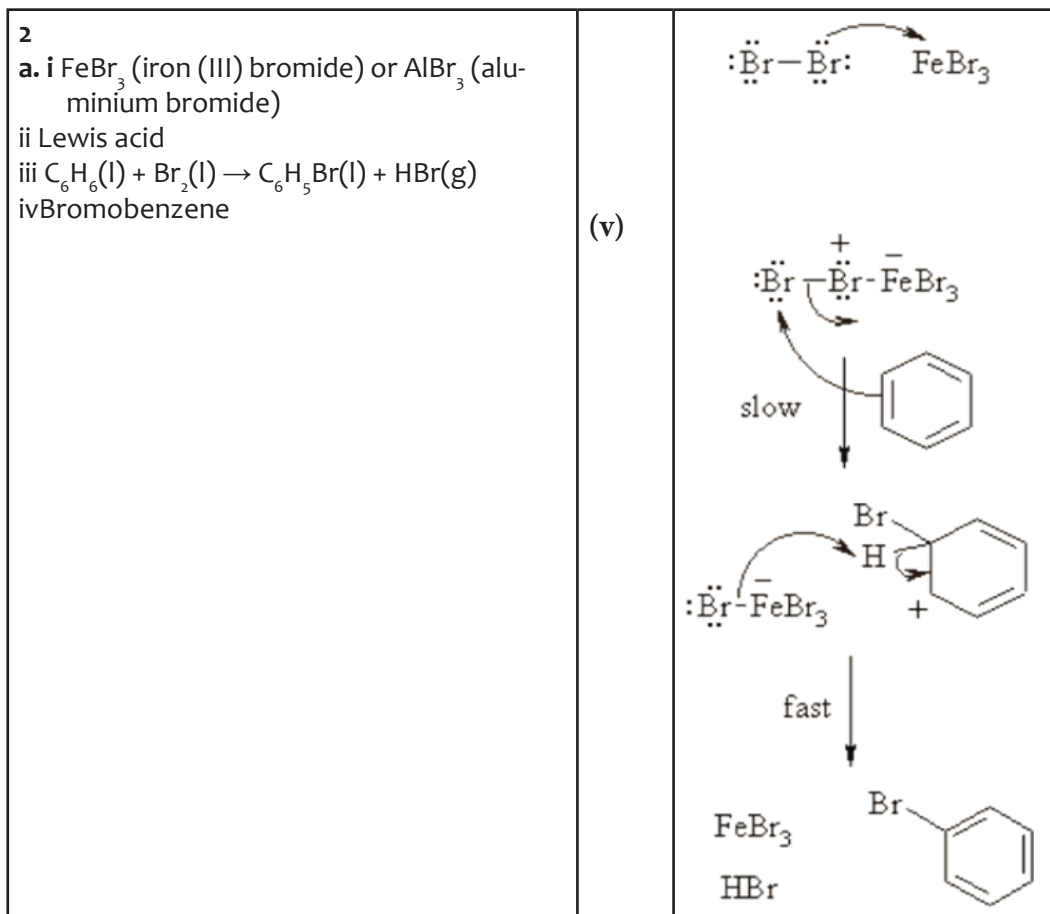

b. i. Cyclohexene is a cyclic alkene with one double bond while benzene has three double bonds but which are delocalised

ii. The double bond in cyclohexene is fixed so that it can approach the bromine molecule more readily than that in benzene ring which is delocalised.

7.

a. Refer to nitration in student's book

b. Refer to Student's book

i. Refer to Student's book

ii. A curly arrow is a type of arrow that shows the movement of a pair of electrons from its tail to head (from the electron rich species to an electron deficient species).

iii. Nitronium ion. It acts as an electrophile.

4.9. Additional activities

Remedial activities

1. What is the difference between aromatic and aliphatic compounds?

Answer: Aromatic compounds are often strong smelling and contain a ring system of delocalised electrons.

2. a. What is meant by hydrogenation?

Answer: Hydrogenation refers to the addition of hydrogen to a molecule

- b. Write an equation of the hydrogenation of benzene.

Answer:

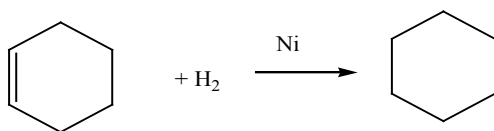

3. Why is benzene used only for industrial processes?

Answer: Due to its toxicity benzene is not safe for domestic commercial use.

4. For each of the questions below, write down the letter corresponding to the right answer.

- i. Friedrich August Kekule's structure of benzene was inspiration of a

- a. Chemist
- b. Nature
- c. Dream
- d. Cloud

Answer: C

- ii. Chlorobenzene is one of

- a. Halogens
- b. Arenes
- c. Halogenoarenes
- d. All of them

Answer: C

- iii. Comparing, Phenol reacts readily then benzene, so it is a

- a. Nucleophile
- b. Electrophile
- c. Protophile
- d. Both a and b

Answer: A

(iv) Bromine water does not react with benzene at

- High temperature
- Low temperature
- Room temperature
- Constant temperature

Answer: C

(v) What is the electrophilic species in the sulphonation of an aromatic compound?

- HSO_3^+
- SO_2^+
- SO_3
- H_2SO_4

Answer: A and C

Consolidation activities

1. a) Give the necessary reagents and conditions for each of the following changes:

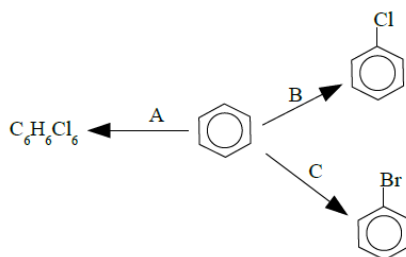

b. The product from reaction **A** shows geometric isomerism even though it does not contain any carbon-carbon double bonds. Explain briefly why.

c. Name the product from reaction **B**.

Answer:

a. A: Bubble chlorine through hot benzene for an hour in the presence of UV light.

B: Bubble chlorine through benzene at room temperature in the presence of either aluminium chloride or iron(III) chloride, but in the absence of UV light.

C: React benzene with bromine at room temperature in the presence of either aluminium bromide or iron(III) bromide, but in the absence of UV light.

(With B and C you don't need to mention both possible catalysts - just choose one of them.)

b. The molecule is a ring of carbon atoms, each with a hydrogen and chlorine atom attached. These can lie above or below the ring. If the chlorine atom on, say, carbon 1 was below the ring, then the chlorine atom on carbon 2 could lie either above or below the ring – producing geometric isomers.

There are obviously lots of variations on this if you consider all the carbons around the ring.

c. Chlorobenzene

2. a) Give the necessary reagents and conditions for each of the following changes:

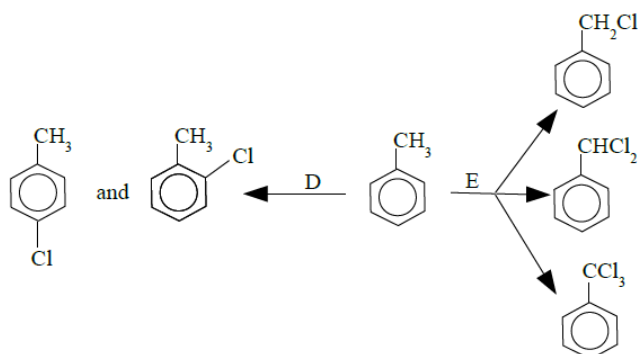

b. Name the products in reaction D.

c. In reaction E you normally get a mixture of products, although you can favour the top one or the bottom one by varying the conditions. How would you aim to get mainly the bottom one?

c. Name the three products of reaction E.

Answer:

a. **D:** Bubble chlorine through methylbenzene at room temperature in the presence of either aluminium chloride or iron, but in the absence of UV light.

E: Bubble chlorine through boiling benzene in the presence of UV light.

b. 4-chloromethylbenzene and 2-chloromethylbenzene

c. Use an excess of chlorine.

d. Chloromethylbenzene, Dichloromethylbenzene, Trichloromethylbenzene.

Extended activities

Analyse the following statements and write the letters corresponding to the correct ones:

1. Which aromatic substitution does **not** require a halogen carrier?

A	$C_6H_6 \text{ ® } C_6H_5NO_2$
B	$C_6H_6 \text{ ® } C_6H_5Cl$
C	$C_6H_6 \text{ ® } C_6H_5CH_3$
D	$C_6H_6 \text{ ® } C_6H_5COCH_3$

Answer: A

2. The reaction mechanism shown below is incomplete.

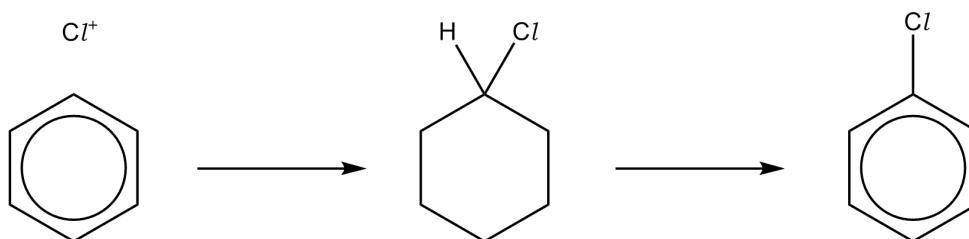

What would be a **correct** addition to this mechanism?

- A curly arrow from Cl^+ to the benzene ring
- A curly arrow from the displayed C–H bond, into the ring, in the intermediate
- An aromatic ring in the C_6 ring in the intermediate
- HCl as a product in the final step

Answer: C

3. Which will not result in a reaction?

- $C_6H_5OH + Br_2$
- $C_6H_5OH + NaOH$
- $C_6H_5OH + Na_2CO_3$
- $C_6H_5OH + HNO_3/H_2SO_4$

Answer: C

4. Which is the correct product formed from the bromination of nitrobenzene?

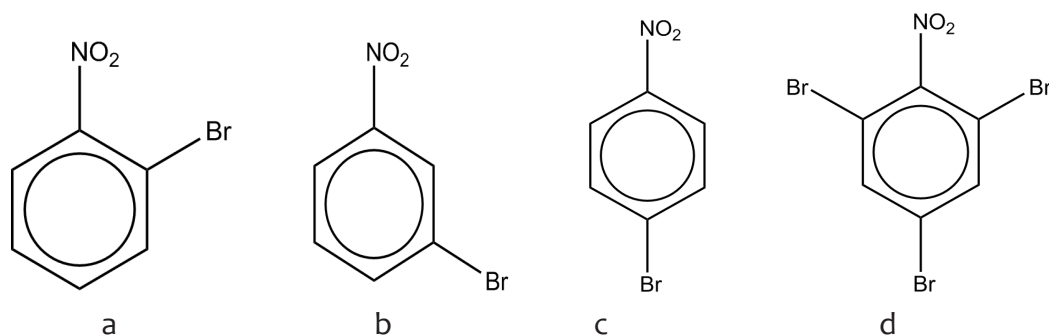

Answer: B

5. Sulfonation of benzene involves an electrophilic substitution mechanism.

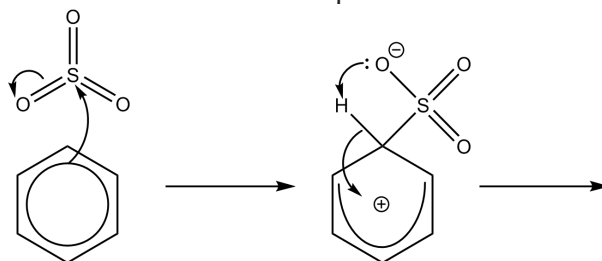

What would be the final product?

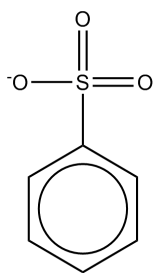

a

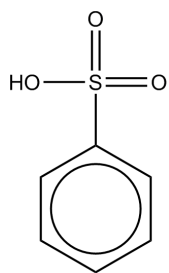

b

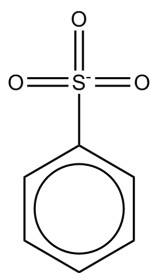

c

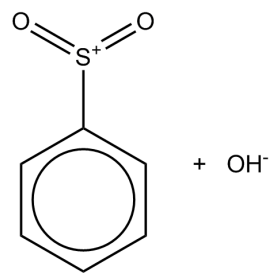

d

Answer: B

5.1. Key unit competence

The learner should be able to relate aromatic ketones, aldehydes, carboxylic acids and amines to their chemical activity.

5.2. Prerequisite knowledge and skills

Learners will understand better this unit concerning derivatives of benzene if they know:

- The chemical properties, physical properties and nomenclature of benzene (studied in senior six unit 4),
- The chemical properties, physical properties and nomenclature of aliphatic compounds (studied in senior from unit one up to 9).

5.3. Cross-cutting issues to be addressed

Environment and sustainability

The growing awareness of the impact of the human race on the environment has led to recognition of the need to ensure our young people understand the importance of sustainability as they grow up and become responsible for the world around them. Hence Environment and Sustainability is a very important cross-cutting issue

Learners need skills and attitudes that will enable them in their everyday life to address the environment and climate change issue and to have a sustainable livelihood.

While teaching this unit concerning derivatives of benzene especially their uses, talk about the environment and its sustainability. For instance:

- Detergents like OMO they are very important but they cause water pollution;
- DDT is a derivative of benzene used, especially in the past, for killing insects but nowadays is no longer used because it is harmful to crops;
- Explosives such TNT (Trinitrotoluene) cause air pollution.

5.4. Guidance on the introductory activity

Before introducing the lesson one of unit five, you will have to introduce the whole unit. Ask learners (in pairs) to attempt the introductory activity from student's book. This activity intends to relate the unit with learners' daily life and to capture their attention.

Give learners 30 minutes and ask them to use library or internet (where is possible) in

order to conduct this introductory activity very well. Learners may not be able to find the right answers but they are invited to predict possible solutions or answers.

Select some groups (2-4) to share their findings to the whole class. After presentation, give your comments showing them how derivatives of benzene are very important in our daily life.

It is not necessary to give them all answers of this introductory activity because they will study them in this unit. So, you can leave learners with the curiosity of knowing the correct answers.

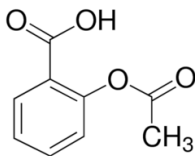
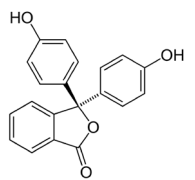
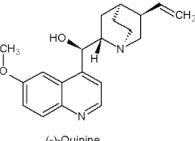
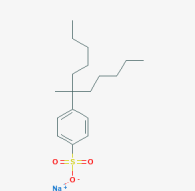
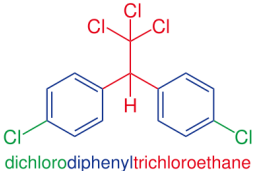
The expected answers of the introductory activity for unit 5	
1) Names and uses	2) Chemical formulae
Aspirin: is a drug used to reduce pain, fever and inflammation	
Phenolphthalein: is an acid-base indicator	
Quinine: is a drug used in the past to treat malaria	 (-)-Quinine
Detergent: is a liquid or powder used to remove dirt, for example from clothes or dishes.	
DDT: is a chemical substance used, especially in the past, for killing insects that harm crops.	 dichlorodiphenyltrichloroethane

Dettol: is a chemical substance used for killing bacteria. It is especially used for treating skin problems. Chloroxylenol is the active ingredient in Dettol.

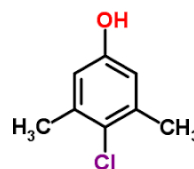

Chloroxylenol
(also known as para-chloro-meta-xyleneol)

3) All these substances contain benzene ring in their structures.

4) Dyes, methyloange indicator, explosives like TNT, etc

5.5. List of lessons/sub-headings

	Lesson title	Learning objectives	Number of periods
1	Effect of substituent groups on the benzene ring	Explain the effects of substituent groups on the benzene ring.	3
2	Phenols	<ul style="list-style-type: none"> • Give systematic names of phenols. • Describe the preparation and reactions of phenol • Test and compare the acidity of phenol with alcohols and carboxylic acids. • State the uses of phenol. 	4
3	Aromatic hydrocarbons	<ul style="list-style-type: none"> • Give systematic names of aromatic hydrocarbons. • Describe the preparation and reactions aromatic hydrocarbons. 	2
4	Aromatic carbonyl compounds	Describe the preparation and reactions of benzaldehyde and phenyl ethanone	3
5	Aromatic Carboxylic acids	Describe the preparation and reactions of benzoic acid	3

6	Aromatic amines	<ul style="list-style-type: none"> Describe the preparation and reactions of phenylamine Compare and contrast the alkalinity of phenylamines with aliphatic amines and ammonia. Explain the azo-coupling reactions of phenylamine in manufacture of dyes and indicators. 	4
7	End unit assessment		2

Lesson 1: Effect of substituent groups on the benzene ring

a. Prerequisites:

Learners will understand better this unit if they know the reactivity of benzene ring, concept of resonance and inductive effects.

b. Teaching resources:

- Chemistry textbooks and other relevant chemistry books from the library
- Where possible use internet

c. Learning activities

This lesson contains one activity:

- Ask learners to form groups of 2-4 (the number of groups and members will depend on your class size and the number of your resources or materials).
- Give learners activity 5.1 (from the student's book)
- As guide or facilitator, move around the class and check if all learners are working.
- Ask learners to present their findings.
- During the presentation ask some questions that lead to lesson objectives.
- Guide learners to make the summary of the lesson themselves. Make sure the following are emphasized on:
 - Deactivators and activators substituents,
 - Ortho, para-directing substituents and meta-directing substituents.
- Make the final conclusion of the lesson.
- After giving final conclusion, assess your learners using **checking up 5.1** (from student's book). Learners can do this checking up individually or in pairs. If you do not have enough time in your lesson, give it as individual home work. Make sure you mark the students' work.

Answers to Activity 5.1

See the answers in student's book for **Effect of Substituent Groups on the Benzene Ring**

Answers to Checking up 5.1

1. Answer: $-\text{CO}_2\text{CH}_3$, $-\text{SO}_3\text{H}$ and $-\text{COCH}_3$ are meta-directing. meta-directing groups are desactivators, decrease the reactivity of benzene ring towards electrophiles. These groups withdraw the electrons from benzene ring through resonance effect, reducing the electron density at the benzene ring.

But, $-\text{OCH}_3$, $-\text{NHCH}_3$ and $-\text{NHCOCH}_3$ are ortho and para-directing. ortho and para-directing groups are activators and increase the reactivity of benzene ring towards electrophiles.

2. Answer: - ortho and para orienting: methyl, methoxyl
- meta orienting substituents: nitro, cyano

3. Answer: The resonance effect enables the halogen substituent to act as ortho and para director. It is also expected to activate the ring to electrophilic attack, but on the contrary it is a ring deactivator. This is attributed to the very high electronegativity of the halogens due to which they withdraw electrons so as to deactivate the benzene ring. In respect of the displacement of electrons the positive resonance effect is not sufficient to compensate the negative inductive effect which deactivates the ring.

4.

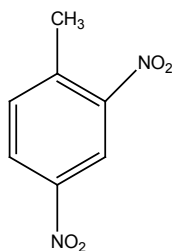

Lesson 2: Phenols

a. Prerequisites:

Learners will understand better this lesson if they have understanding on the concept of aliphatic alcohols and benzene.

b. Teaching resources:

- Chemistry textbooks
- Where possible use internet

- Distilled water, phenol, ethanol, ethanoic acid test tubes, test tube racks, beakers, litmus papers (blue and red), bromine water and iron (III) chloride.

c. Learning activities

This lesson has three activities: Activity 5.2 (a), Activity 5.2 (b) and Activity 5.2 (c).

Activity 5.2 (a)

- Give learners activity 5.2 (a) (from the student's book).
- Ask learners to carry out this activity in pairs
- Move around the class and check if all learners are working.
- Ask learners to present their findings.
- Guide learners to make the summary of the lesson themselves.

Answers to Activity 5.2 (a)

For answers of this activity refer to the student's book on Phenol.

Answers to Activity 5.2 (b)

- Form groups
- Give learners the above resources
- Ask learners to carry out the activity **5.2 (b)** (from the student's book).
- Ask learners to present their observations and deductions to the whole class.
- Guide learners to make the summary of the lesson themselves.

In the beaker number one containing phenol the blue litmus paper will turn red because phenol has the behaviour of an acid compared to other alcohol like ethanol.

In the second beaker, the litmus paper remains blue because ethanol is neutral.

In the third beaker which contains ethanoic acid the blue litmus paper turns red because ethanoic acid is an acidic.

Activity 5.2 (c)

For this activity use the methodology used in previous activity 5.2 (b).

For its answers refer to chemical tests of phenol in the student's book.

Answers to Checking up 5.2

1. a. The O-H bond is weaker in phenol than in phenylmethanol. This is because the lone pair of electrons on the oxygen atom of phenol becomes associated with delocalized electrons of the ring. Because of this partial double bond develops between carbon and oxygen with the result that C-O bond is strengthened and the O-H weakened as the electronic density is displaced towards the ring. This thus makes phenol a stronger acid than phenylmethanol.
- b. Phenoxide ion is a weaker base than ethoxide ion because the lone pair of electron on phenoxide ion is not available (it is delocalized) but in ethoxide the lone pair of electrons is available (not delocalised) hence, ethoxide can fix the proton easily.
- c. 4-nitrophenol is less volatile than 2-nitrophenol because in 4-nitrophenol the two function groups are wide part and forms intermolecular hydrogen bonds while in 2-nitrophenol, the two functional groups are close and cause intramolecular hydrogen bonding. The intramolecular forces are easier to break than the intermolecular hydrogen bonds in 4-nitrophenol. Therefore, 4-nitrophenol has a higher boiling point than 2-nitrophenol.

2.

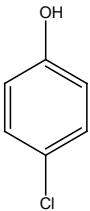
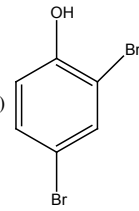
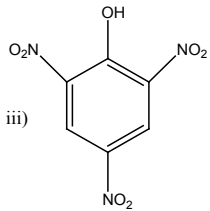
 <p>i)</p>	 <p>ii)</p>	 <p>iii)</p>
4-chlorophenol 4-chloro-1-hydroxybenzene or p-chlorophenol	2,4-dibromophenol	2,4,6-trinitrophenol

3.

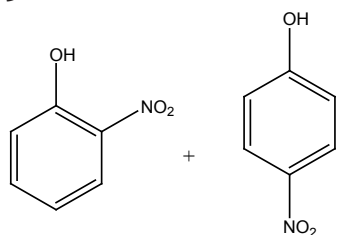

Lesson 3: Aromatic hydrocarbons

a. Prerequisites:

Learners will understand better this lesson if they have understanding on the concept of aliphatic hydrocarbons covered in senior five unit 2 and 3.

b. Teaching resources:

Internet, Chemistry textbooks and other relevant chemistry books from the library.

c. Learning activities

This lesson has one learning activity: **Activity 5.3**

As a facilitator, guide learners to learn by doing activity 5.3, as described below:

- Ask learners to carry out this activity in pairs (or groups of 3 or more depending on the size of your classroom) and provide them with resources to be used while carrying out their research;
- Move around the class and check if all learners are working;
- Ask learners to present their findings;
- Guide learners to make the summary of the lesson themselves;
- Make the final conclusion of the lesson and if possible, evaluate them with checking up 5.3 as class work or as homework.

Answers to Activity 5.3

For answers of this activity refer to the student's book on aromatic hydrocarbons.

Answers for Checking up 5.3

1

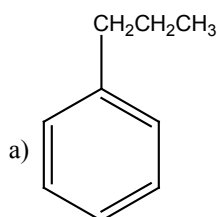

Propylbenzene

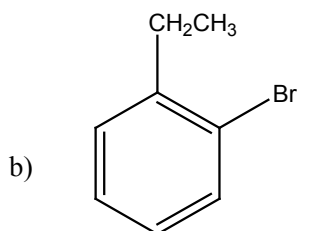

1-bromo-2-ethylbenzene
Or o-bromoethylbenzene

2.

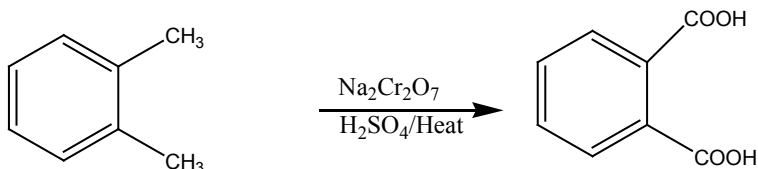

3. These two products can be prepared using benzene and chloromethane or bromomethane in the presence of Lewis acid.

Lesson 4: Aromatic carbonyl compounds

a. Prerequisites:

Learners will understand better this lesson if they have understanding on the concept of aliphatic carbonyl compounds covered in senior five unit 6.

b. Teaching resources:

Chemistry textbooks and other relevant chemistry books from the library

Internet

c. Learning activities

This lesson has one learning activity: **Activity 5.4**

As a facilitator, guide learners to learn by doing activity 5.4, as described below:

- Ask learners to carry out this activity in pairs (or groups of 3 or more depending on the size of your classroom) and provide them with resources to be used while carrying out their research;
- Move around the class and check if all learners are working;
- Ask learners to present their findings;
- Guide learners to make the summary of the lesson themselves;
- Make the final conclusion of the lesson and if possible, evaluate them with checking up 5.4.

Answers to Activity 5.4

For answers of this activity refer to the student's book on Aromatic carbonyl compounds.

Answers for Checking up 5.4

1)

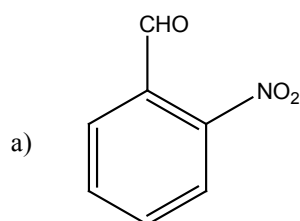

2-nitrobenzaldehyde

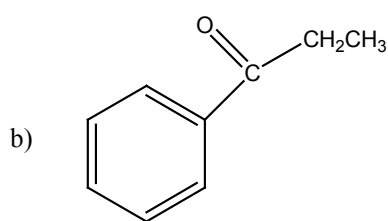

Phenylpropanone

2)

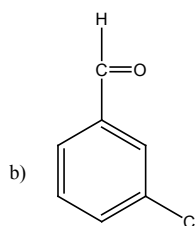
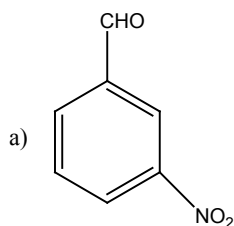

(refer to the student's book: **preparation of aldehydes**)

Lesson 5: Aromatic Carboxylic acids

a. Prerequisites:

Learners will understand better this lesson if they have understanding on the concept of aliphatic carboxylic acids covered in senior five unit 7.

b. Teaching resources:

Internet, Chemistry textbooks and other relevant chemistry books from the library.

c. Learning activities

- This lesson has one learning activity: **Activity 5.5**
- As a facilitator, guide learners to learn by doing activity 5.5, as described below:
- Ask learners to carry out this activity in pairs (or groups of 3 or more depending on the size of your classroom) and provide them with resources to be used while carrying out their research;
- Move around the class and check if all learners are working;
- Ask learners to present their findings;
- Guide learners to make the summary of the lesson themselves;
- Make the final conclusion of the lesson and if possible, evaluate them with checking up 5.5.

Answers for Activity 5.5

For answers of this activity refer to the student's book (Aromatic Carboxylic acids) .

Answers for Checking up 5.5

Refer to the student's book: Preparation of carboxylic acid

Lesson 6: Aromatic amines

a. Prerequisites:

Learners will understand better this lesson if they have understanding on the concept of aliphatic amines covered in senior five unit 9.

b. Teaching resources:

Internet, Chemistry textbooks and other relevant chemistry books from the library

c. Learning activities

- This lesson has one learning activity: **Activity 5.6**
- As a facilitator, guide learners to learn by doing activity 5.6, as described below:
- Ask learners to carry out this activity in pairs (or groups of 3 or more depending on the size of your classroom) and provide them with resources to be used while

carrying out their research;

- Move around the class and check if all learners are working;
- Ask learners to present their findings;
- Guide learners to make the summary of the lesson themselves;
- Make the final conclusion of the lesson and if possible, evaluate them with checking up 5.6.

Answers for Activity 5.6

For answers of this activity refer to the student's book (Aromatic amines).

Answers for Checking up 5.6

1.

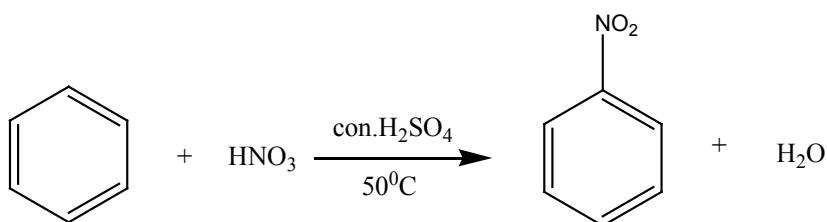

2. a

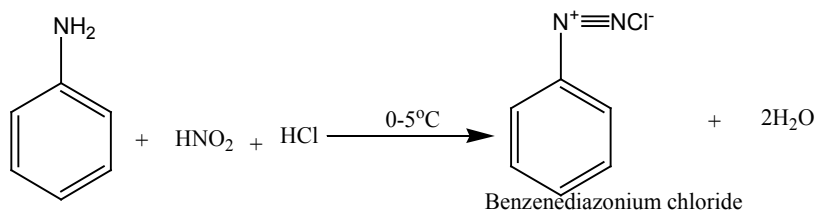
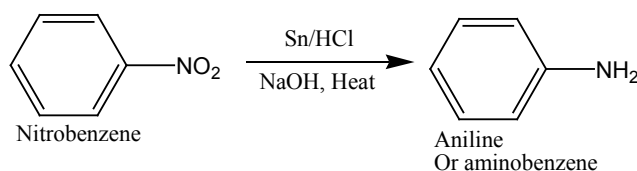

b. Nitrous acid and hydrochloric acid at the temperature less than 10°C .

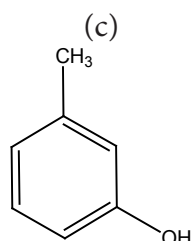

5.7. Summary of the unit

Many important chemical compounds are derived from benzene by replacing one or more of its hydrogen atoms with another functional group. Some examples of derivatives of benzene are:

Phenols: the simplest member is hydroxybenzene or simply called phenol. The presence of hydrogen bonds makes the melting temperatures of phenols higher than those of hydrocarbons of comparable molecular mass. Compared to aliphatic alcohols, phenol (hydroxybenzene) is about one million times more acidic, although it is still considered a weak acid and less acidic than carboxylic acids.

Alkylbenzene: the simplest member is methylbenzene (Toluene). An alkylbenzene is simply a benzene ring with an alkyl group attached to it.

Aromatic carbonyl compounds (aromatic aldehydes and aromatic ketones). These compounds contain carbonyl group attached to the benzene ring. Benzaldehyde is a typical aromatic aldehyde and undergoes chemical reactions involving the side chain and the benzene ring. The simplest aromatic ketone is phenylethanone. The most typical reactions of the carbonyl groups are **nucleophilic addition**.

Aromatic carboxylic acids: the simplest member is benzoic acid which is used as food preservative.

Aromatic amines: the commonly used is phenylamine (aniline or aminobenzene). This aniline is a weaker base than ammonia and aliphatic amines. Aniline and its ring-substituted derivatives react with nitrous acid to form diazonium salts. A large number of benzene derivatives (like dyes can be synthesized from diazonium salts).

It has been found experimentally that in general ortho-para directing substituents activate the benzene ring and thus enhance the rate of reaction with electrophiles. On the contrary, the meta directing substituents deactivate the ring and retard the rate of reaction as compared to unsubstituted benzene.

5.8. Additional Information for teachers

Multiple Substituent Effects

When a benzene ring bears two or more substituents, both its reactivity and the site of further substitution can usually be predicted from the cumulative effects of its substituents.

In the simplest cases all the available sites are equivalent and substitution at any one of them gives the same product.

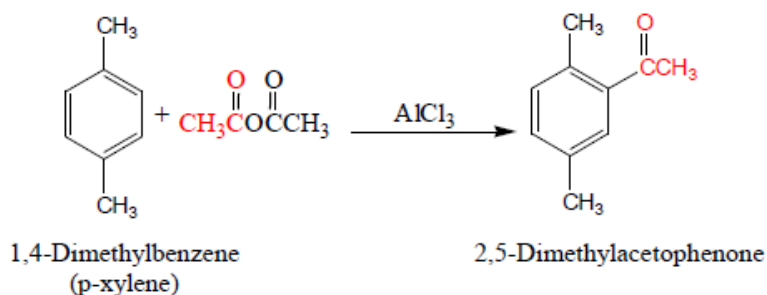

Often the directing effects of substituents reinforce each other. Bromination of p-nitrotoluene, for example, takes place at the position which is ortho to the ortho, para-directing methyl group and meta to the meta-directing nitro group.

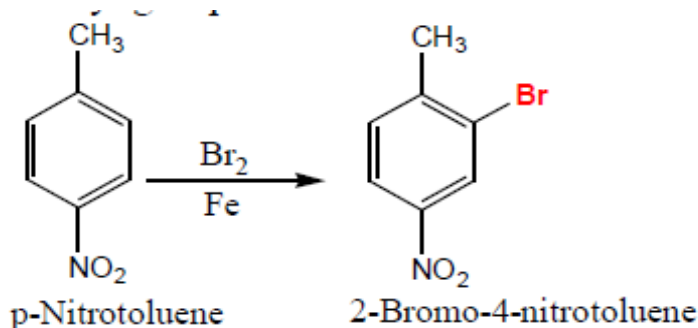

In almost all cases, including most of those in which the directing effects of individual substituents oppose each other, *it is the more activating substituent that controls the regioselectivity of electrophilic aromatic substitution...*

When two positions are comparably activated by alkyl groups, substitution usually occurs at the less hindered site.

5.9. End unit assessment Answers

Learning and assessment standards:

Explain the properties of derivatives of benzene (aromatic ketones, aldehydes, carboxylic acids and amines) related to their functional groups, independently evaluating evidence to reach valid conclusions

1. Answer: **b, c, e** and **f**
2. Phenols: **A** and **D**
Not phenols but alcohols: **B** and **C**
3. a. Formation a white precipitate
b. Because -OH group is an activator, -OH group increases the reactivity of benzene ring.
c. (See the answer in student's book: uses of phenol)

4. Answers:

a. 2-bromo-4-nitrobenzoic acid

b. 3-chlorophenylamine

c. 3-chloromethylbenzene

d. Pentachlorophenol

e. 4-aminobenzoic acid

5. a.

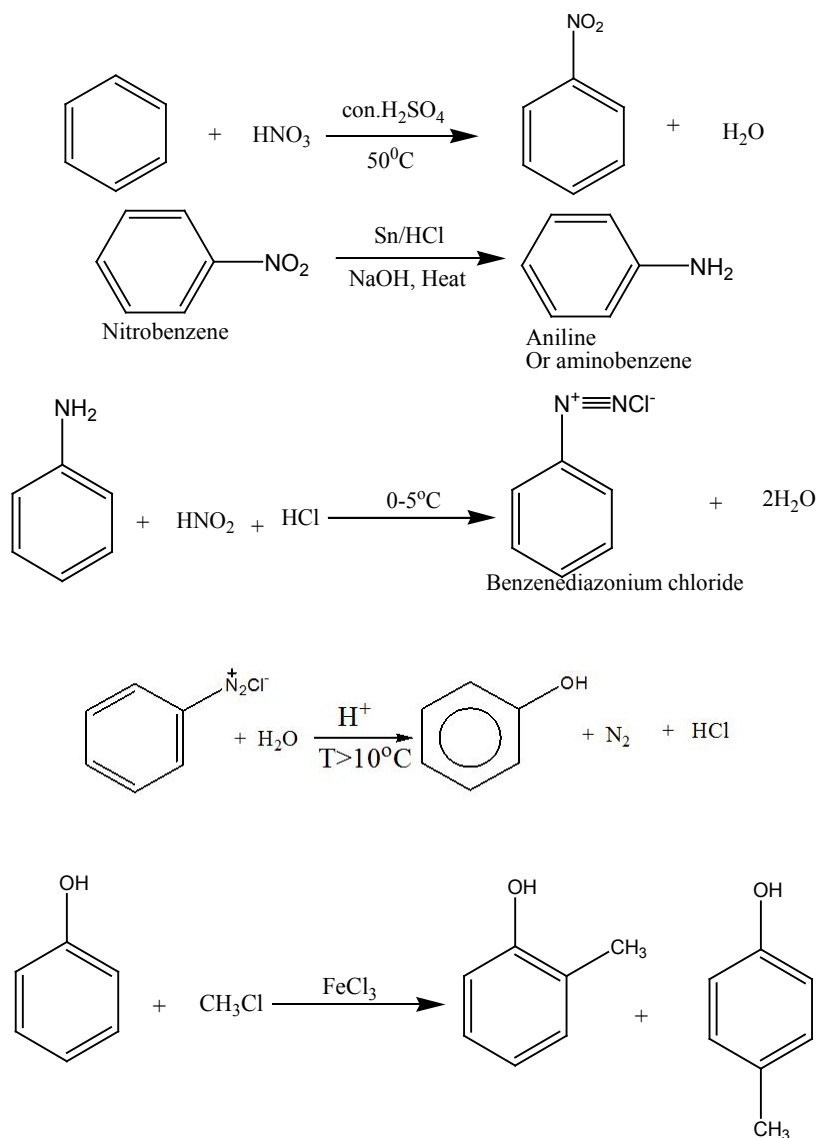

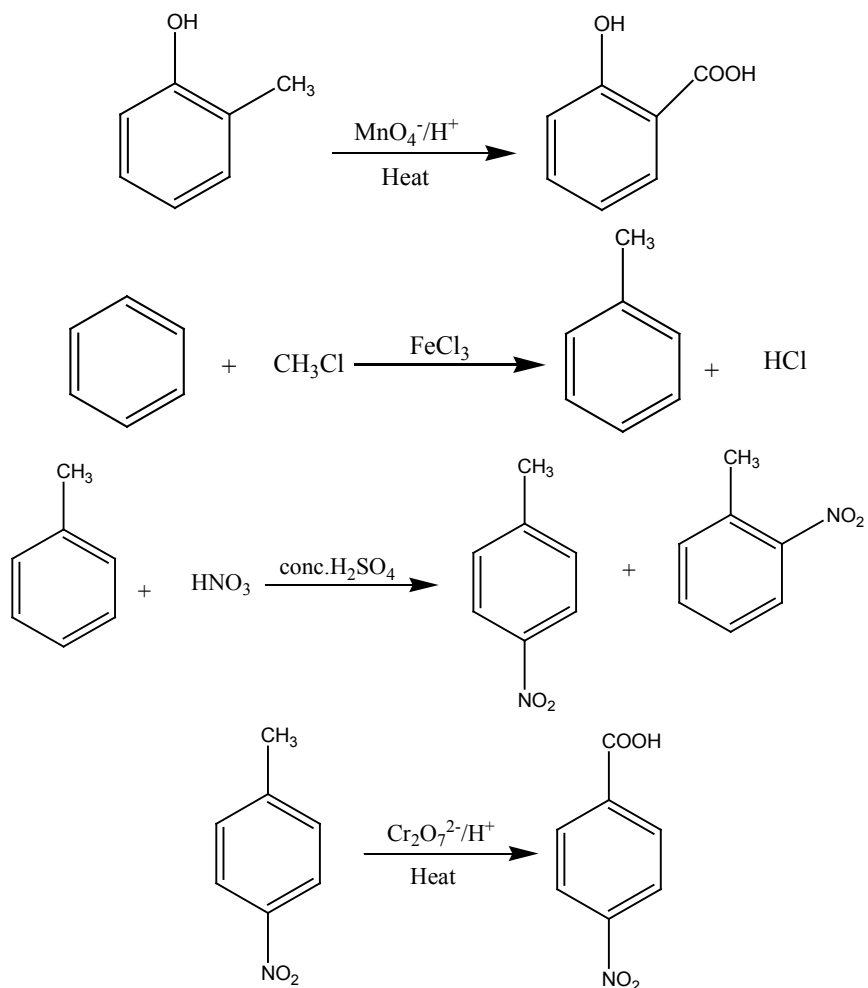

Answer:

Step	Reagents	Conditions
I	Cl_2	U.V light
II	$\text{NaOH}_{(aq)}$ or $\text{KOH}_{(aq)}$	Warm /heat
III	Conc. HNO_3	Conc. H_2SO_4 as catalyst and heat or reflux

a. Answer: Reduction

b.

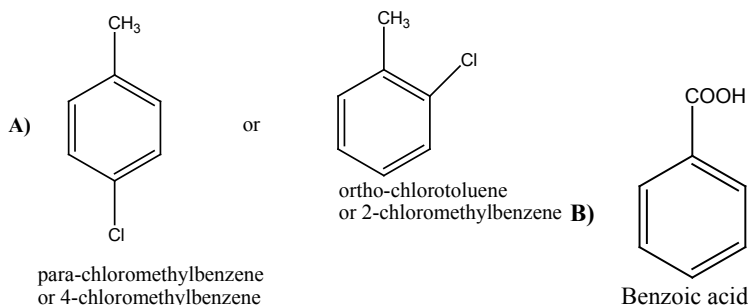

c. Answer: Step I: Free radical substitution
Step II: Nucleophilic substitution(SN)

7.

- a. **i.** Concentrated nitric acid in the presence of H_2SO_4 and Heat.
ii. Electrophilic substitution (nitration). For the mechanism, use student book on nitration of benzene
- b. Zn, Sn or Fe can be used together with a mineral acid (HCl or H_2SO_4) in the presence of an alkali.
- c. Use of ammonia in the presence of an alcohol (ethanol) under pressure.
- d. Answer:** K is a weaker base than ammonia because the lone pair of electron on K is not available (it is delocalized) but in ammonia the lone pair of electrons is available (not delocalised) hence, ammonia can fix the proton easily.

5.10. Additional activities

Remedial Activities:

1. The correct name for the molecule shown below would be:

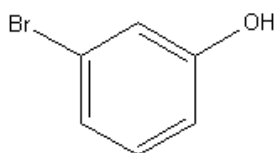

- | | |
|----------------------|------------------|
| a. o-bromophenol | c. m-bromophenol |
| b. Hydrobromobenzene | d. p-bromophenol |

Answer: c

2. What is another name for p-aminobenzoic acid that would still be considered to be correct?

a. 4-aminobenzoic acid	c. 2-aminobenzoic acid
b. 3-aminobenzoic acid	d. 1-aminobenzoic acid

Answer: a

3. Which of the following names is correct for this structure?

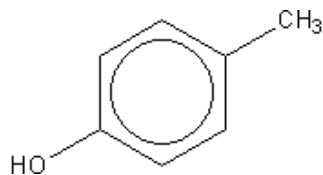

- a. 4-hydroxytoluene
- b. *p*-methylphenol
- c. 1-hydroxy-4-methylbenzene
- d. All of the above.

Answer: d

4. Halogenation of benzene requires which of the following catalysts?

- a. FeCl₃
- b. H₂O
- c. H₂SO₄
- d. Ni

Answer: a

5. Which of the following processes is useful in the formation of synthetic detergents from aromatic compounds?

- a. Halogenation
- b. Nitration
- c. Sulfonation
- d. More than one answer choice is correct

Answer: c

6. Which of the following is a weak acid?

- a. Aniline
- b. benzene
- c. phenol
- d. toluene

Answer: c

7. DDT is no longer used in agriculture because

- a. It is an insecticide
- b. it increases crop yields
- c. it decreases the spread of malaria and typhus
- d. it resists biodegradation

Answer: d

8. Water is not a byproduct in which of the following aromatic substitution reactions?

- a. Halogenation
- b. nitration
- c. sulfonation
- d. More than one answer choice is correct

Answer: a

9. Which of the following is not an appropriate name for this compound?

a. 1,2-dihydroxybenzene

c. m-hydroxyphenol

b. 1,2-benzenediol

d. Catechol

Answer: c

Consolidation activities:

1. Benzoic acid is prepared from benzene as shown below:

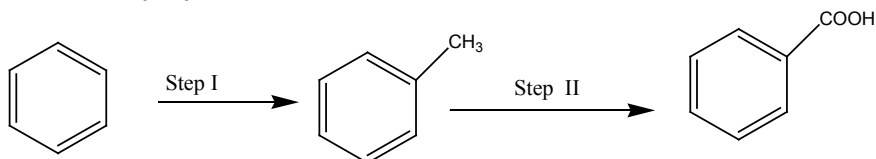

a. i. Give the reagents and conditions for step I

ii. Give the reagents and conditions for step II

b. i. Give the structure of the organic product formed when methylbenzene and chlorine react in the presence of ultra violet light.

ii. Give the structures of the two isomers formed when methylbenzene reacts with chlorine in the presence of FeCl₃.

Answers: See the answers in student's book unit 5.

2. The chart below shows a synthetic route for the preparation of compound Z starting with compound Y:

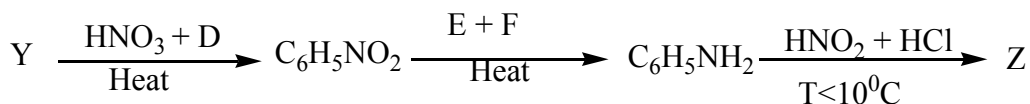

a. State the names of compounds Y, D, E, F and Z.

b. Show the reaction mechanism in the formation of compound: C₆H₅NO₂ from compound Y.

c. Explain why compound Y undergoes electrophilic substitution more readily than C₆H₅NO₂.

d. Which name is given to the reaction which takes place in the production of Z?

Answer:

a. **Y:** Benzene

D: Concentrated sulphuric acid

E: Sn, Fe or Zn

F: HCl

Z: Benzenediazonium chloride

b. See the answer in student's book unit 4

c. The compound $C_6H_5NO_2$ has the nitro group which acts as deactivators.

d. Diazotisation reaction.

Extended activities:

1. How can you prepare the insecticides so known as DDT(Dichloro Diphenyl Trichloroethane):

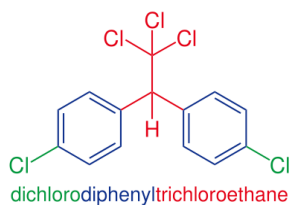

Answer:

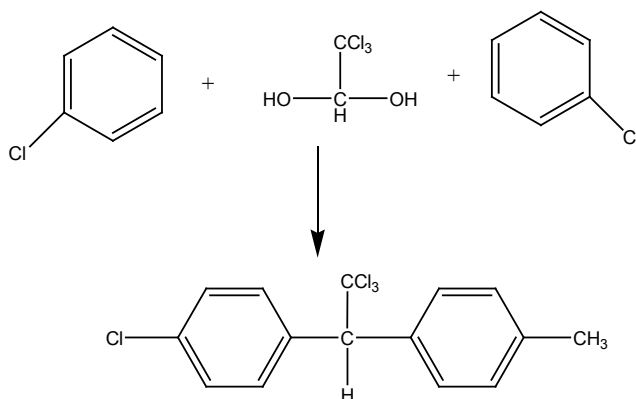

2. How can you prepare Aspirin (Acetylsalicylic acid):

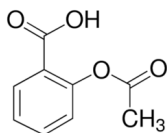

Answer:

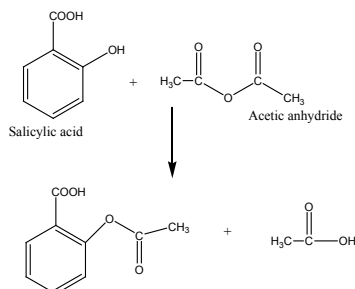

UNIT 6: POLYMERS AND POLYMERIZATION

6

6.1. Key unit competence

To be able to relate the types of polymers to their structural properties and uses

6.2. Prerequisite knowledge and skills

Students will learn better to relate the types of polymers to their structural properties and uses if they have understanding on: balancing chemical equations; draw the displayed structural formulae of organic compounds and give names using IUPAC system; chemical reactions like esterification and formation of other compounds like amides; reactions of carboxylic acids, amines; nomenclature of inorganic and organic compounds (covered from senior one to senior five).

6.3. Cross-cutting issues to be addressed

Environment and sustainability

Polymer manufacturing is a very big business. There is great, worldwide demand for synthetic polymers, as well as natural polymers that have been altered to make them more useful. Synthetic polymers can come in a variety of forms, such as common plastics, the nylon of a jacket, or the surface of a non-stick frying pan, but these human-made materials have a detrimental impact on ecosystems. That is why learners need to be aware and be responsible for the use and the ways to deal with old polymers in order to protect the environment. Here environment and sustainability cross cutting issue comes in and has to be related to the environment of learners but going hand in hand with the national policy on how to protect environment especially they have to avoid using plastic bags in daily life.

Young people should be addressed about this issue so that they can avoid to the disposition of waste materials everywhere. Waste materials should be collected together in areas reserved for them according to their categories. The majority of old materials made of polymers can be recycled to form new ones without polluting environment.

This will help them to understand the importance of sustainability as they grow up and become responsible for the world around them.

Inclusive education

This unit requires learners to carry out a lot of researches to be able to understand first, then share and discuss on things like structure of monomers, polymers, and so on. This

may be challenging to students with special educational needs especially slow learners. However, as teacher you can organise your class and use different strategies to help all learners understand well. Some of the strategies to be used are provided below:

- Be patient! If you find that the student takes longer than others to learn or to do an activity, allow more time.
- Do activities together with the student.
- Gradually give the student less help.
- Let the student do the activity with his colleagues and encourage them to help each other.
- Divide the activity into small achievable steps.
- Remember to praise and say 'well done' when the student learns something new or makes a strong effort.

Comprehensive sexuality education

When introduction polymer and polymerization, learners should be reminded for that it is similar to the way individual students join to form different peer groups where their group resembles polymer and the individual students would be considered as monomers, their reason of grouping would be considered as the bond. Peer groups among students is sometimes a challenge, because there are some of them who are bonded by drugs or any negative attitude, so individual students have to be carefully from the reason being of the group.

6.4. Guidance on the introductory activity

Introductory activity for unit 6, student's book S6.

Polymers and polymerization seem to be new for students but chemical reactions that happen are familiar with the majority of them.

Therefore, the introduction of this unit to students of senior six would be simple. The introductory activity can attract interest of students as it is built on the materials that are around everywhere.

Here is a guide of how this activity can be performed by students guided by the teacher.

- Put your students in groups of 3-4(or even 5 depending on the size of your class)
- Provide them with books or worksheets with the introductory activity, unit 6 from student's book S6.
- Give them time between 15 and 20 minutes to read, analyze, interpret and discuss about the activity. Here they have to observe and analyse the objects in the pictures and answer the questions asked about them. Let them use books or search from internet if possible, in order to discover what they don't discover directly.
- Call one or two groups to present their findings. You may note some key points at this stage.
- Ask other members (randomly) to give their input. Don't worry if some of them fail to reach the exact results. They get to understand as the unit progresses.

Address your views about their presentations. But it is not necessary to conclude. Just motivate them to create curiosity in them.

Answers to introductory activity:

1: Nylon rope, 2: fiber thread, 3: piece of silk cloth, 4: rubber balloon, 5: plastic materials (including cups), 6: rubber tyres, 7: plastic tubes.

Uses

Nylon ropes: when stretched between two points, clothes are being dried when they are hung on it.

Fiber thread: used to make different things including carpets, curtains, draperies, sheets and pillow cases and wall coverings.

Piece of silk cloth: used to make high-fashion clothes, lingerie and underwear.

Rubber balloon: Balloons are used for decorative purposes or entertaining purposes, while others are used for practical purposes such as meteorology, medical treatment, military defense or transportation.

Plastic materials: Example a cup can be used to carry out liquid substances.

Rubber tyres: It is the outer part of wheel that helps car to move smoothly. When is old, it can be reused of other different activities.

Plastic tubes: they are used for fluid flow or structural systems through buildings. It is used as insulation or sheathing for electrical or heating assemblies.

- a. They are all made by long chain molecules.
- b. They have light weight, though, not corrosive, poor conductors of heat and electricity, coloured. They all have long chains or all are made by polymers.

6.5. List of lessons/sub-heading

#	Lesson title	Learning objectives	Number of periods
1	Definition of monomer, polymer and polymerization	<ul style="list-style-type: none">• Define the terms monomer, polymer and polymerization• Develop the culture of working in groups.	2

2	Types of polymers	<ul style="list-style-type: none"> • Describe the formation of polymers • Describe addition and condensation polymerization • Write equations to show how nylon 6,6, polyester, Dacron, Kevlar, natural rubber, PVC and Bakelite are formed • Prepare phenol-methanol polymer (bakelite). • Develop orderliness in the presentation of research work 	4
3	Classes and types of polymers	<ul style="list-style-type: none"> • Discuss the advantages and disadvantages of both natural and synthetic polymers • Respect others 'opinions during debate 	2
4	Properties of polymers	<ul style="list-style-type: none"> • Explain the terms thermosetting and thermo-softening of the plastics. • Explain the biodegradability property of polymers based on their chemical structure. 	1
5	Importance of vulcanization in rubber processing	<ul style="list-style-type: none"> • Describe the importance of vulcanization of rubber 	1
6	Uses of polymers and their effect on the environment	<ul style="list-style-type: none"> • Relate the structure and properties of polymers to their uses in the plastic and textile. • Appreciate the socio-economic importance of polymers • Develop the sense responsibility to protect the environment against the hazards of plastics. 	1
7	Management of old polymer materials	<ul style="list-style-type: none"> • Explain the biodegradability property of polymers based on their chemical structure. 	1
8	Summative assessment		2

Lesson 1: Definition of monomer, polymer and polymerization

a. Prerequisites/Revision/Introduction:

Students will learn better this lesson if they have knowledge on how to write molecular and to draw the displayed structural formulae of organic compounds and give names using IUPAC (covered in senior five)

b. Teaching resources

Use periodic table of elements, worksheets or books; projectors and/or chalkboard.

c. Materials and chemicals

- 500ml 2% milk
- 60ml vinegar
- 100 ml beaker
- 2 beakers of 1L each
- 1 spoon
- 1 strainer
- Aluminium foil
- Thermometer
- Hot plate or Bunsen burner and stand
- Matches if using a Bunsen burner

d. Learning activities

Writing molecular formula of some of the molecules (monomers) and drawing their displayed structures is among simple activities that can be performed successfully by students. Make sure you help each student to do this as something that can make him/her feel proud of chemistry.

e. Answers with cross reference to students' textbook

Methodological steps:

As a facilitator, you are expected to guide students to learn by doing activity 6.1, as described below:

Answers to Activity 6.1, student's book S6

- a) Polymer is a large molecule (macromolecule or giant molecule) composed of smaller molecules (monomers) linked together by intermolecular covalent bonds.
b) Polymerization is the process in which monomer units are linked by chemical reaction to form long chains (polymers).
2. Plastic cups, plates and forks; bed covers, different types of clothes, ...

Procedure

- Hold up a button and ask the students to identify it.
- Ask the students what do they think the button is made out of. (plastic) Do they know raw material of plastic? (petroleum)

- Hold up the beaker of milk and ask if they think the button and milk are related. They will be unable to answer or say no. Then ask if they know the components of milk. The teacher will get various answers such as water, calcium, fat and protein. Doesn't sound like petroleum is a part of it, does it?
- Tell the students that we are going to try and make some plastic anyway.
- Turn on the Bunsen burner or hotplate.
- Place beaker of milk over heat. Stir constantly.
- Place thermometer into the milk. Heat milk until it reaches 37°C.
- Remove from heat and immediately add vinegar, stirring constantly. Here, the teacher should ask the students what they think will happen when the vinegar is added.
- The solution will rapidly separate into curds suspended in a clear yellow liquid.
- Strain the solution through the strainer into the empty 1L beaker. Hold up the beaker for the students to see the clear liquid.
- Scoop the curd onto a large piece of aluminium foil and press out into a thin layer. Pass the aluminium foil around the class.
- Tell the students that this can be dried overnight. The experiment should have been done previously so that the teacher can now pass around dried pieces of the pressed curd. Ask them to try and break it. Pass around the button with the dried curd and ask them to see if they can observe any similarities between the button and dried curd.
- Ask the students to remember what we said was in milk. A big component of milk is protein, which is called casein. When we added the acid, we caused the protein in the milk to coagulate and form a polymer, which is a big chain of protein or other substance of high molecular weight. The addition of heat helped to speed up the reaction. This process is called polymerization. A plastic is a polymer, as it is a long chain of molecules with high molecular weight.
- Tell the students that what we have seen is the creation of casein plastic, which is a natural plastic. We have come to associate plastic as synthetic, with petroleum-based products dominating the market. However, this experiment shows the type of natural plastics used before the discovery of synthetic plastics.
- Hold up the button to the students and tell them that this was just one of the many things that casein plastic was used for.

To give them a little something extra to think about, mention that cheese is made in a very similar way, using a different acid.

Theory

Milk is a colloid, which is defined as a suspension of large molecules—such as proteins—in a solution such as water. Essentially, milk is a suspension of protein globules in water.

Polymerization is the process of forming a polymer by combining small molecules or monomers into long chains. The resulting compound is of high molecular weight. Polymerization can be used to make some useful materials in the manufacturing field. Plastics are well-known polymers. Most plastics are synthetic and made from oil and

natural gas, but some plastics are found in nature. 80% of 2% cow's milk is made up of the polymer casein, a protein. This protein can go through polymerization to create a natural plastic, as the casein molecules are associated together in long chains. Proteins are generally unstable and are prone to unfolding, which changes the natural state of the protein. This process is called denaturing. The addition of acid, in this case vinegar, causes the casein protein to unfold and rearrange into the long chains of a polymer. The process then causes the casein to precipitate out of the milk, leaving a clear watery substance behind. The casein can then be formed into various shapes before drying. In our experiment, thermal energy in the form of heat was applied to speed the process and cause a more complete separation.

Casein was once used to manufacture buttons, as it was a hard, strong substance and did not dissolve in water. However, due to the costs of the raw materials, as demand for product increased, a cheaper, petroleum-based plastic replaced the casein. Old buttons lying around the house could be casein-based. Casein plastic is still used in manufacturing today to aid glue in book binding as well as serving as a glaze for paper.

Conclusion

This is a unique discrepant event for an introduction to polymers and polymerization in a Senior 3 chemistry class. The experiment is quite safe, with the only safety consideration being the use of a Bunsen burner or hot plate. The teacher should take the opportunity to use proper safety precautions when using the Bunsen burner or hot plate, as students take cues from passive observation. They are much more likely to be lax with safety procedures if the teacher disregards them.

The event will create disequilibrium for the students, as they have been taught to expect plastic to be a synthetic, petroleum-based product. It will be difficult for them to associate the ingredients of milk and other natural plastics in the same category as a button or a computer. They may even experience an odd sensation as they realize that they "ingest" plastic-producing products daily.

Answers to Checking up 6.1

1. a) Polyvinyl acetate:

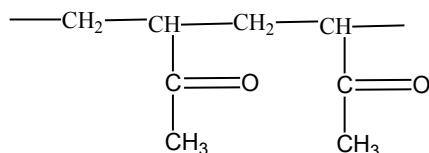

b. 2-Chlorobuta-1,3-diene

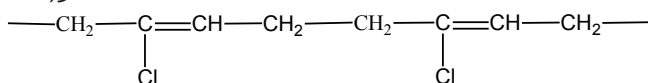

c. $\text{---CH}_2\text{CHCl---CH}_2\text{CH(CH}_3\text{)---}$

Or

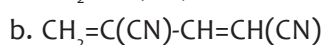
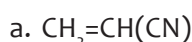
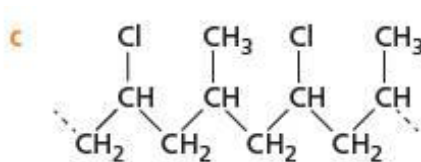
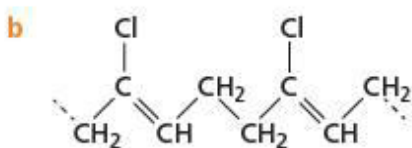
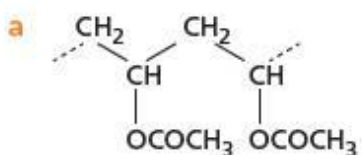

Lesson 2: Types of polymerization

a. Prerequisites/Revision/Introduction:

Students will learn better types of polymerization if they have knowledge on types of chemical reactions; completing and balancing chemical equations covered in senior two and four; additional reactions; condensation reactions covered in senior four.

b. Teaching resources

Use worksheets or books; projectors and/or chalkboard

Materials: glass rod, beakers, funnel, measuring cylinder, dropper and filter paper.

Chemicals: Glacial acetic acid, 40% formaldehyde solution and Phenol, conc. H_2SO_4 .

c. Learning activities

You can start by asking your students questions about types of chemical reactions. This lesson has two questions in activity 6.2 with a practical.

d. Answers to activities and checking up with cross reference to students' textbook

Methodological steps:

As a facilitator, you are expected to guide learners to learn by doing activities from 6.2

Answers to Activities in 6.2, student's book S6

1. A and B are polymerization reactions

A has same type of reactants and one product which means that there is chemical combination of one unit repeating

B has two different reactants and two chemical products, which means that if two substances are joined together, there is a product formed and water is released.

2. Addition polymerization is a process where monomers are linked together to form a polymer, without the loss of atoms from the molecules while condensation polymerization is a process where two or more monomers chemically combine to form a polymer with elimination of simple molecules like water, ammonia, hydrogen chloride, alcohol Example: The reactions A and B above are respectively addition polymerization and condensation polymerization.

Answers to Checking up 6.2

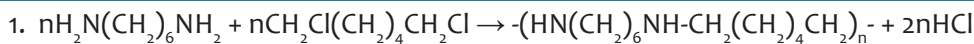

2. Addition polymerization is a process where monomers are linked together to form a polymer, without the loss of atoms from the molecules while condensation polymerization is a process where two or more monomers chemically combine to form a polymer with elimination of simple molecules like water, ammonia, hydrogen chloride, alcohol

Example of additional polymerization

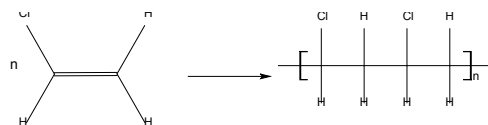

Example of condensation polymerization

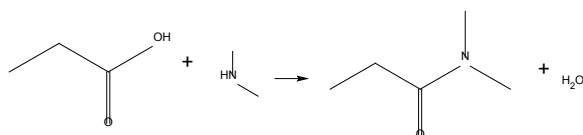

3. (a)

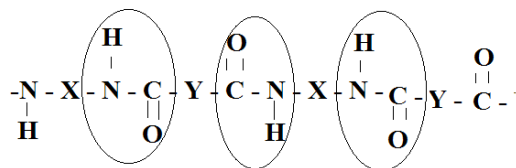

b. Amide bond

4. a. Condensation polymerization

b. $\text{HOOC}-(\text{CH}_2)_4-\text{COOH}$ and $\text{H}_2\text{N}-(\text{CH}_2)_6-\text{NH}_2$

c. Proteins such as wool and silk

Lesson 3: Classes and types of polymers

a. Prerequisites/Revision/Introduction:

Students will learn better this lesson if they have knowledge on types of chemical compounds covered in senior two and four, general knowledge on the properties of metals and plastics.

b. Teaching resources

Use worksheets or books; projectors and/or chalkboard

Materials: teacher improvises by looking for materials such as plastics, rubber and fibres and brings them in class; therefore, it will help students to discover on their own.

c Learning activities

You can start by giving your students questions of activity 6.3. This lesson has 3 questions in activity 6.3.

d. Answers with cross reference to students' textbook

Methodological steps:

As a facilitator, you are expected to guide learners to learn by doing activity 6.3, as described below:

Answers to activity 6.3, S6 students' book

- a. There are two types of polymers: synthetic and natural. Synthetic polymers are derived from petroleum oil, and made by scientists and engineers. Examples of synthetic polymers include nylon, polyethylene, polyester, Teflon, and epoxy. Natural polymers occur in nature and can be extracted. They are often water-based. Examples of naturally occurring polymers are silk, wool, DNA, cellulose and proteins.

Summary in the form of table:

Natural polymers	Synthetic polymers
Natural polymers are compounds that can be found naturally in our environment	Synthetic polymers are polymer compounds that are produced artificially by humans
They occur naturally	They are synthesized or do not occur naturally
They are produced from biological processes	They are produced from chemical processes
Most polymers are easily degraded by biological processes	Most polymers are hard to degrade naturally by biological processes

- b) i. Commonly known materials are made by natural polymers: sugar (starch), silk clothes, cotton and wool clothes, rubber materials, etc...
- ii. Commonly used materials which are synthetic polymers: all materials which are fibres, plastics (like plastic utensils, plastic tubes), glue, plastic bags, etc.

Plastics v/s metals

2. Before determining whether to use plastic or metal, it is important to first understand the potential advantages of each.

Advantages of plastics:

They have advantages including:

- Ease of forming: due to its low melting point and high malleability compared to other materials
- Reduced finishing: Unlike most metals, plastics can be colored prior to fabrication.
- Reduced finishing: most metals, plastics can be colored.
- Fast production: Plastic fabrication often involves quick cycle times and fast turnover rates.
- Light weight: Plastics weigh less than metals of comparable dimensions.
- Chemical substances: plastics are less susceptible to damage from chemicals or chemical reactions such as oxidation, rusting than metals

Disadvantages of plastic fabrication

- Limited wear resistance: plastic has low resistance to high temperatures, acidity and other corrosive elements.
- Structural weakness: they are unsuited for applications with heavy equipment components.

Advantages of metals:

- Heat resistance: metals have higher melting point and are less likely to degrade under elevated temperatures.
 - Improved strength: metals tend to be stronger, harder, and more durable than plastic materials.
 - Cost-effective: metals are cost efficient and in high volume or long term production.
 - Disadvantages of metals:
 - Secondary operations: Metals are more likely to require post-fabrication with is time-consuming such as finishing, painting, etc.
 - High start-up fees: metals tooling are more expensive than comparable plastic fabrication tooling.
 - As conclusion, choosing what to use, will depend from what kind of activity depending on characteristics of each.
3. (a) A = fiber B= plastics C = Rubber
- (b) They are different materials used in our daily life with different uses, but all are made are made by polymers.

Answers for checking up 6.3

1. (a)

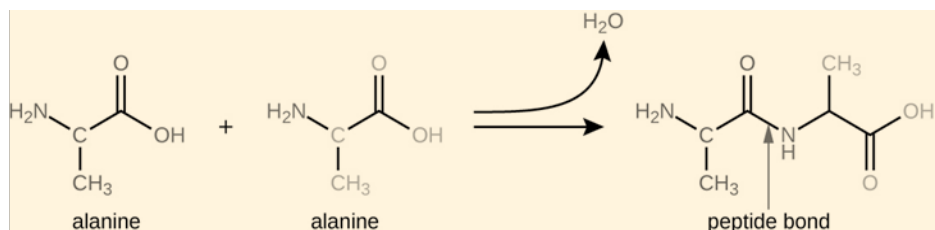

(b) Protein

2.

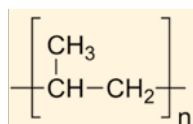

(a)

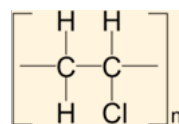

(b)

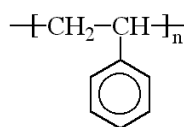

(c)

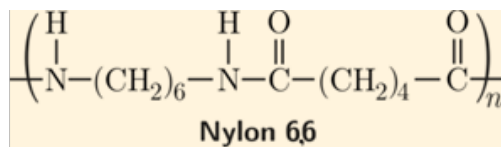
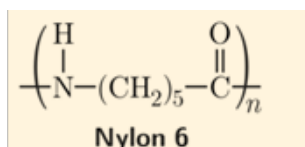

(d)

(e). $-(\text{CF}_2-\text{CF}_2)_n-$, Or,

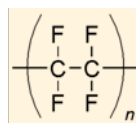

Lesson 4: Properties of polymers

a. Prerequisites/Revision/Introduction:

Students will learn better this lesson if they have knowledge on properties of organic compounds covered in senior five.

b. Teaching resources

Use clip videos, worksheets or books; projectors and/or chalkboard

c. Learning activities

While working in pairs, you can start by asking your students, questions about properties of polymers

Methodological steps:

As a facilitator, you are expected to guide learners to learn by doing activities 6.4

Answers to activity 6.4, from student's book S6

1. Biodegradable polymers are the polymers that are fully decomposed into carbon dioxide, methane, water, biomass and inorganic compounds under aerobic or anaerobic conditions and the action of living organisms while non-biodegradable polymers are polymers which are resistant to environmental degradation thus accumulate in form of waste.
2. a) Thermosets:
 - b) Thermoplastics are polymers that can be softened by heating, allowed to cool and harden, and therefore can be resoftened many times.
3. a) In both structures, there are long chains. The difference is that in structure A the chains are mixed but they are not connected (no links) but in the structure B, there are links between chains.
 - b) They are polymers. In A they form long chains without strong bonds between chains while in structure B, the long chains are bonded together by cross links (links between chains)

Answers to checking up 6.4, from student's book S6

1. a) Bio-degradable: Substance or object capable of being decomposed by bacteria or other living organisms and therefore avoiding pollution.
- b) Advantage of biodegradable plastics is that they completely break down and provide required space to dispose other waste materials.
- c) Researchers have worked on developing biodegradable plastics with the hope of protecting environment but the production methods and applications of biodegradable plastics could still be detrimental to environmental and human health. Biodegradable plastics behave differently when recycled, and have the potential to negatively influence human health. If the food packaging materials are recycled, their physical properties could change, allowing degraded chemical compounds and external contaminants to enter the food.

However, when biodegradable plastics decompose, they produce methane gas, a major contributor to global warming. Thus, the biodegradable nature of these plastics poses economic and ecological problems in the current waste management infrastructure

Finally, the last obstacle to surmount is the proper disposal of biodegradable plastics. In order for biodegradable plastics to be effectively disposed of, the current waste management infrastructure must change, or methods with less economic and environmental costs must be developed

2.

- | | |
|------|------|
| a. c | f. c |
| b. c | g. b |
| c. c | h. b |
| d. b | i. a |
| e. b | j. c |

Lesson 5: Importance of vulcanization in rubber processing

a. Prerequisites/Revision/Introduction:

Students will learn better this lesson if they have knowledge of previous lesson on rubber covered in previous lessons

b. Teaching resources

Use clip videos, worksheets or books; projectors and/or chalkboard

c. Learning activities

You can start by asking your students, questions about rubber

Methodological steps:

As a teacher to facilitate teaching and learning process, you are expected to guide learners to learn by doing activities 6.5

Answers to activity 6.5, from student's book S6

1. Vulcanization is process used to convert natural rubber or related polymers to improve its resilience, elasticity and durability by heating them with Sulphur or other equivalent curatives or accelerators.
2. a) Yes. A and B are all rubber materials
b) All have the same nature, they are polymers called rubber. The difference is that A is not vulcanized while B is vulcanized.

Answers to checking up 6.5

11. a) Importance of vulcanization:
 - Vulcanized rubber last long
 - It increases tensile strength
 - Rubber becomes insoluble in any solvent
 - It increases tear strength
 - improve its resilience, elasticity and durabilityb) i) Accelerators: guanidine, thiazoles
ii) density, colour, price
iii) phenolics, phosphites
2. a) Vulcanized rubber: is a material that undergoes a chemical process known as vulcanization. This process involves mixing natural rubber with additives such as sulphur and other curatives.
b) Vulcanization makes rubber much stronger, more flexible, and more resistant to heat and other environmental conditions.
3. Vulcanization is process used to convert natural rubber or related polymers to improve its resilience, elasticity and durability by heating them with Sulphur or other equivalent curatives or accelerators. During this process, the rubber undergoes a multiple series of chemical change.

Lesson 6: Uses of polymers and their effect on the environment

a. Prerequisites/Revision/Introduction:

Students will learn better this lesson if they have knowledge on the use of commonly known polymers.

b. Teaching resources

Use clip videos, worksheets or books; projectors and/or chalkboard

c. Learning activities

You can improvise and bring materials know in daily life and you ask them their uses and their effects on the environment especially when they are old.

Methodological steps:

As a facilitator, you are expected to guide learners to learn by doing activities 6.5

Answers to activity 6.6, from student's book S6

Answers to checking up 6.6, from student's book S6

1. Polyester fibres, yarns and ropes are used to make car tire reinforcements, fabrics for conveyor belts, safety belts, coated fabrics and plastic reinforcements with high energy absorption.

The property of polyesters is that they have high tenacity and durability. They resist for strong and repetitive movements.

2.

- They can cause erosion because they do not allow water penetration in the soil
- They can cause atmospheric air pollution when they are degrading they emit harmful chemical substances in air.
- The can cause soil pollution through degradation in the soil

Lesson 7: Management of old polymers

a. Prerequisites/Revision/Introduction:

Students will learn better this lesson if they have knowledge on how to deal with wastes in environment covered in senior one

b. Teaching resources

Use clip videos, worksheets or books; projectors and/or chalkboard

c. Learning activities

You can start by asking your students to list methods of dealing with wastes and then ask them to answer the questions about how to deal with old polymers

Methodological steps:

As a facilitator, you are expected to guide learners to learn by doing activities 6.7

Answers to activity 6.7, from student's book S6

1. The image shows waste plastic materials. It teaches that people do not have to throw anywhere waste plastic materials. They have to be taken to the landfill.
2. REUSE: This is a process of using the polymers more than once. This encompasses the entire spectrum of used goods. Spanning from collectables, antiques and memorabilia to general used goods retail and wholesale. Dealing in second hand items typically involves the salvage of used items and may dismantle into components. Beyond salvage and to enhance reuse the industry includes repair and refurbish, remanufacturing.

RECYCLE

Recycling is one of the most important activities that can be applied to reduce the impacts of the plastics used in industry. Recycling is a waste-management strategy; it is a technique that can be used to reduce the environmental impact and resource depletion. Recycling provides opportunities to reduce oil usage, carbon dioxide emissions and the quantities of waste requiring disposal.

DISPOSAL

Old polymers disposal is the action of getting rid of old polymers. The disposal of non-biodegradable polymers is a significant problem. There are three options:

(i) Burying in landfill sites

This is widespread in all developed countries but is a completely unsustainable practice, as each landfill site will eventually fill up. Landfill sites are also unsightly and unhygienic.

(ii) Burning

This is a technique to dispose some materials. However, burning polymers releases greenhouses gases such as carbon dioxide and can also release toxic gases, depending on exactly type of polymer being burned.

Answers to checking up 6.7, from student's book S6

Reuse

Advantages:

- Energy and raw materials savings
- Reduced disposal needs and costs
- Costs savings for business and consumers as a reusable product is often cheaper than the many single use products it replaces.

Disadvantages:

- Reuse often requires cleaning or transport, which have environmental costs
- Sorting and preparing items for reuse takes time which is inconvenient for consumers and costs money for businesses.

Recycling

Advantage is that it provides a liveable environment for the future.

Disadvantages:

- It is expensive
- Some wastes cannot be recycled
- Technological push needed
- Separation of useful material from waste difficult

Disposal

Advantage is that it is inexpensive. Advantage is that it produces health hazards: insects, rodents and it can cause air pollution. It also creates ground water and run-off pollution.

6.6. Summary of the unit

Polymerization is the formation of extremely long molecules (polymers) from small molecules called **monomers**. The plastics and rubber are examples of the most common polymers which are commonly used in both everyday life and in medical applications. The exact properties of polymers depend on a variety of chemical details and on their specific chemical details.

There are two main types of polymerization reactions: Addition and condensation.

In addition polymerization, the polymer has the same empirical formula as the monomer but a higher molecular mass. An example is the polymerization of chloroethene (vinyl chloride) to form poly(chloroethene), PVC.

For condensation polymerization, monomers join by production of polymer and elimination of small molecules (such as water or ammonia)

Polymers have two classes; natural and synthetic polymers and can be classified into three classes; plastics, rubber and fibres

Polymers have got properties; they are thermosetting plastics and thermo softening properties where on the other side they can be biodegradable or non-biodegradable polymers.

Among the classes, rubber is more used and its vulcanization is needed to improve its quality.

In our daily life, materials made by polymers are used and sometimes have effects on environment.

Polymers are used in a broad range of industries such as textiles, packaging, stationery, plastics, aircraft, construction, rope, toys. When polymers get old, measures should be taken in order to deal with them; that is why polymer management is needed. Three methods could be used; reuse, recycling and disposal.

6.7. Additional information for teachers

More definitions related to polymers

Oligomer: An oligomer is a molecule that consists of a few monomer units (oligos, for “a few”), in contrast to a polymer that, at least in principle, consists of an unlimited number of monomers.

Tensile strength: Density, melt viscosity and tensile strength are a few important mechanical properties of a polymer. These are highly influenced by molecular weight of polymers. Tensile strength is increases with molecular mass of the polymer up to 20000. Beyond that the increase is negligible.

Elasticity: The property by which the polymer undergoes elongation several times under the applied force and regains their original size when the force is released fully is called elasticity.

The elastic property of elastomers is mainly because of their liner and coiled polymer chains.

6.8: End unit assessment

ANSWERS TO END UNIT ASSESSMENT QUESTIONS

1. Crosslinking: is a process of where one polymer chain bonds to another while thermosetting is a process of becoming permanently hard and rigid, for some polymers when they are subjected to heat.

Thermosetting polymers are suitable for high temperature; they retain their strength and shape even when heated.

2. a) Its inertness comes from the way that they are saturated compounds with single bonds only in their structures.

b) Their structures make them less reactive which increases their uses because they are chemically stable. They have excellent electrical insulation and very good chemical resistance.

c) When they are disposed or put in landfill, they do not degrade which is a challenge to environment.

3. a) Carboxylic group and amine

b) They have the same joining group, amide linkages.

5. a) There is hydrogen bond.

6 Examples of synthetic polymers; nylons, terylene, and polystyrene

7 strengthen the polymer

a) -Natural addition polymer:

Polyisoprene (natural rubber): used in manufacturing tyres, tubes, etc

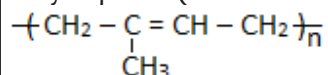

Monomer: Isoprene

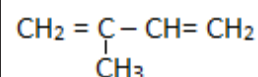

-Synthetic addition polymer:

Polyvinylchloride (PVC) - uses: pipes, plastic bottles, doors (rigid PVC), rain coats (flexible PVC)

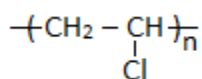

Monomer: Chloroethene (vinyl chloride)

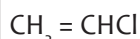

-Natural condensation polymer:

Polymer: Starch, $(\text{C}_6\text{H}_{10}\text{O}_5)_n$ - uses: textile and paper industry, source of ethanol

Monomer: Glucose; $\text{C}_6\text{H}_{12}\text{O}_6$

-Synthetic condensation polymer

Polymer: Terylene (polyester) - uses: textile industry (clothing, fishing lines, ropes, bottles...)

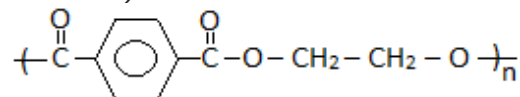

Monomers:

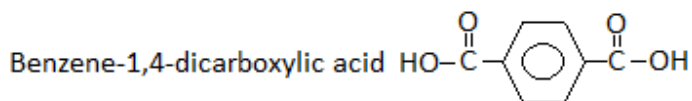

Ethane-1,2-diol $\text{HOCH}_2 - \text{CH}_2\text{OH}$

- b) (i) Fillers are solid inert materials added to synthetic polymers or rubber to change their physical properties or simply dilute it for economy (to increase the bulk of a polymer)
- ii) Plasticizers are substances added to synthetic polymers to make them flexible, e.g. benzene-1,2-dicarboxylic acid added to thermosetting plastics to make them soft and readily remolded.
- c) i) Vulcanization is a process hardening rubber by heating natural rubber with sulphur or sulphur compounds
- ii) By heating natural rubber with sulphur, atoms of sulphur react at both the double bond and at the ethylenic hydrogen such that the sulphur atoms form cross links with the rubber molecules giving the rubber greater elasticity and tensile strength. Formation of cross links also reduces sliding between the rubber molecules
- iii) Name the monomer units in natural rubber
- iv) SBR, Styrene – butadiene – rubber (the most widely used synthetic rubber). It is produced by copolymerization of butadiene and styrene in a ratio of 3:1 using free radical initiators. Use: tyres production

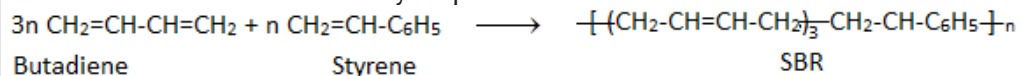

Butadiene

Styrene

SBR

6.9. Additional activities

Remedial Questions

1. Why is bakelite a thermosetting polymer?

Bakelite being a high cross-linked polymer and cannot be reshaped on heating. Hence, bakelite is thermosetting polymer.

2. How is vulcanization done?

Vulcanization is carried out by heating raw rubber with sulphur in appropriate ratio and a suitable additive at a temperature range between 373K to 415K. On vulcanization sulphur form cross links at reactive sites of double bonds and thus rubber gets stiffened. In the manufacture of rubber, 5% sulphur is used as a vulcanizing agent.

Consolidation Questions

1. The amino acid “serine” has the structure :

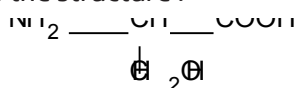

Show the structure of the zwitterion of the above amino acid.

- What name is given to the polymers formed by amino acids?
- Show the structure formed when the above amino acid is dissolved in an acidic solution.

Answer:

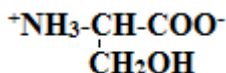

Condensation polymers

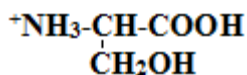

State the type of polymerization leading to the formation of the polymers given in the table below. In each case, write the name and the structural formula of the monomers.

Polymer	Type of polymerization	Structural formula of the monomers	Name of the monomers
Polyester (terylene)			
Polyamide (Nylon 6,6)			
Polystyrene			

Answer:

Polymer	Type of polymerization	Structural formula of the monomers	Name of the monomers
Polyester (terylene)	Condensation	$\begin{array}{c} \text{HO} - \text{C}(=\text{O}) - \text{C}_6\text{H}_4 - \text{C}(=\text{O}) - \text{OH} \\ \text{HOCH}_2 - \text{CH}_2\text{OH} \end{array}$	Benzene-1,4-dioic acid Ethane-1,2-diol

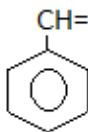
Polyamide (Nylon 6,6)	Condensation	$\text{H}_2\text{N}-(\text{CH}_2)_6-\text{NH}_2$ $\text{HO}_2\text{C}-(\text{CH}_2)_4-\text{CO}_2\text{H}$	Hexane-1,6 diamine and Hexane-1,4-dioic acid
Polystyrene	Addition		Phenylethene (styrene)

Extended Questions

1. Terylene is a polymer made from ethane-1,2-diol and benzene-1,4-dicarboxylic acid. The monomers are:

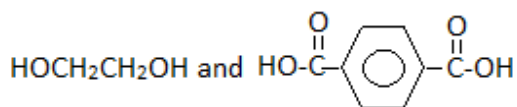

- Give the structure of Terylene showing only one repeat unit
- What type of polymer is Terylene?
- How would you convert

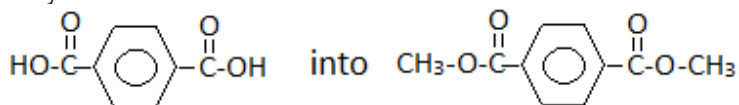

State the reagent and condition

Answer:

a)

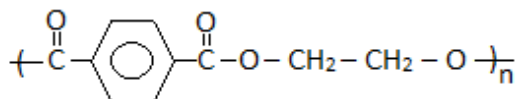

- Terylene is a condensation polymer (polyester)
- Add CH_3COOH / conc. H_2SO_4 catalyst, heat

2. a) Give one example and use of a synthetic thermosetting plastic

b) Nylon 6,10 can be formed by reacting-1,6-diamino hexane with decanedioyl dichloride,

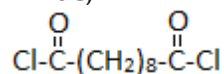

i) Write an equation for the formation of nylon 6,10

ii) State the type of polymerization involved in the formation of nylon 6,10

c) State one use of nylon 6,10

Answer:

a) An example and use of a synthetic thermo setting plastic: Bakelite used in making saucepan handle, electrical switches and sockets, etc.

b) i) An equation for the formation of nylon 6,10

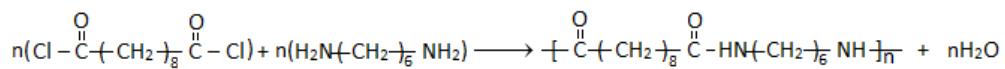

ii) Type of polymerization involved in the formation of nylon 6,10: Condensation polymerization

c)

- Manufacture of surgical gloves
- Manufacture of fishing nets, carpets
- Manufacture of curtains

UNIT 7: SOLVENT EXTRACTION AND COLLIGATIVE PROPERTIES

7

7.1 Key unit competency:

The learner should be able to apply partition and Raoult's law to separate mixtures, determine the molecular and formula masses of compounds using colligative properties.

7.2 Prerequisite

Students will learn well this unit: **The Solvent Extraction and Colligative Properties**, if they have better understood on Unit 4: Covalent bond and molecular structures especially intermolecular forces covered in senior four, nomenclature of organic compounds in Unit 1, unit 11: solutions and titration, Unit 10: Phase diagrams, Unit 11: Solutions and titration, Unit 14: Enthalpy change of reactions covered in senior five and Dalton's law of partial pressures covered in Physics O-Level.

7.3 Cross-cutting issues to be addressed

Financial Education

Solvent extraction is used in daily life; for example solvent extraction of pyrethrum in Musanze district, solvent extraction of tea factories in Rwanda, so it is useful. Solvent extraction plants give to many people especially chemists work to do, so money is brought into the economy, leading to better quality of Rwandese life. So, you have to be aware that students who are studying the solvent extraction need to know how these works lead to the income.

Financial education has a key role of not only improving knowledge of people but also transforming this knowledge into action. In this unit, students must acquire knowledge, skills, attitudes and values about essential oil extraction and selling it, for example at Sulfo Rwanda in making soaps, beauty oil, perfumes, etc., and that may bring money to people in their families and contributes to the development of our country.

Fractional distillation can be used as a simple method to increase the concentration of alcohol in fermented alcoholic beverages. Rwandans are among the consumers of alcohol and most types of spirits are imported. So, making the spirits from our wines, by fractional distillation, can bring money into our economy.

Standardization culture

This unit, **Solvent Extraction and Colligative Properties**, requires carrying out some experiments. The products used have the labels on which there is indicated expired

date; the students have always to check if they are not using expired chemicals. When doing experiment they have to use the quantity said and have to record the data and results accurately. This leads the students to buying the products which are not expired when they are at home.

7.4 Guidance on introductory activity

Solvent extraction and colligative properties are new topics for students but they are familiar with the types of mixtures/solutions (miscible and immiscible solutions) and their separation methods used, and physical properties of substances like boiling point and melting point etc...

Therefore, the introduction of this unit to senior six students would be quite simple. The introductory activity can attract the students to enter in the lesson if well done. Here, you have a guide of how this activity can be performed by students. This activity will be done in the laboratory.

- Depending on the size of your class and laboratory, put the students into 4-6 groups.
- Provide them the materials required in the activity
- Allow them 5 minutes to read the procedures
- Let them perform the activity during 15 minutes (5 minutes for the first and 10 minutes for the second); and write their observations.
- Call two or three group representatives to present their findings (for each activity). You have to note some key points at this stage.
- Randomly, ask other students to give their input. Don't worry if some of them fail to reach the exact results. They get to understand as the unit progresses.
- Give your point of views about their presentations and motivate them to create curiosity.

Proposed Answers about Introductory activity for unit 7, students book S6.

1. Refer to S5 student's book, unit 10

2. Expected answer: see student book introduction

3. Yes, there is. Water is used as solvent and banana as solute.

Juice is extractable fruit contents of cells or tissues obtained by mechanical process from sound, ripe fruits. Raw banana juice is turbid, viscous and gray in colour. Transformation of colour from green to yellow indicates ripening of bananas that contains starch containing sucrose, glucose, fructose as soluble sugars. The solubility of a given solute in a given solvent typically depends on temperature.

Juice can be extracted traditionally with spear grass by the help of hands and feet, mechanically in aluminium chamber through gear system and hot water extraction.

4. See student book introduction

5. Iodine distributes in two liquids. Pair of immiscible liquids form two layers. When a solute is added it may dissolve in both liquids (water layer and organic layer, e.g. 1,1,1-trichloroethane).

6. In this case iodine divides itself between the two layers. It may well be more soluble in one solvent than the other. After standing, iodine can be seen as a pale brown solution in water and in the organic layer, 1,1,1-trichloroethane as a pink solution. Iodine molecules pass from one layer to another until equilibrium is established.

7.5 List of Lessons

#	Lesson title	Learning objectives	Number of periods
1	Introductory Activity	Develop a culture of working in a team during experiment. Respect of procedure in experiments.	1
2	Definition of partition coefficient and solvent extraction	Appreciate the importance of partition coefficient in solvent extraction as a separation technique. Calculate the amount of the solute extracted from the solvent.	2

3	Raoult's law	<p>State the Raoult's law.</p> <p>Apply Raoult's law to determine the vapour pressure and mole fraction of ideal solutions</p> <p>Appreciate the importance of fractional distillation in separation of miscible liquids. Interpret boiling point and vapour pressure composition curves of both ideal and non-ideal mixtures.</p> <p>State examples of the applications of the distillation methods used in various industries.</p>	10
4	Colligative properties	<p>Explain colligative properties.</p> <p>Appreciate the importance of colligative properties in determination of molecular masses of the polymers.</p> <p>Describe the effect of the solute on vapour pressure, boiling and freezing points of the solvent.</p>	5
5	End unit assessment		3

Lesson 1: Definition of partition coefficient and solvent extraction

a. Prerequisites/Revision/Introduction:

Students will learn well this lesson if they have knowledge and skills about Unit 11: Solutions and titration covered in senior five.

b. Teaching resources

Books, projectors and/or chalkboard

c. Learning activities

This lesson starts by doing the introductory activity in student book and this activity can be performed by every student easily because they studied solution and titration in senior five. The activity is done in groups. Make sure that each student participates.

Methodological steps:

As a facilitator, you are expected to guide students to learn by doing introductory activity: see introductory activity answer.

Answers to activity 7.1, student's book S6

(a) The concentration of propanoic acid in the aqueous layer and in the organic layer may be calculated as follows:

$$\text{Mol of acid in } 10.0 \text{ cm}^3 \text{ of aqueous layer} = \text{mol of } NaOH = 0.02 \times \frac{12.0}{1000}$$

$$[Acid]_{aq} = \left(\frac{1000}{10.0} \times 0.020 \times \frac{12.0}{100} \right) \text{mol dm}^{-3} = 0.024 \text{mol dm}^{-3}$$

$$\text{Initial amount of propanoic acid} = \left(0.10 \times \frac{100}{1000} \right) = 0.010 \text{mol}$$

$$\text{Mol of propanoic acid in aqueous layer} = \left(0.024 \times \frac{100}{1000} \right) = 0.0024 \text{mol}$$

$$\text{Mol of propanoic acid in organic layer} = 0.010 - 0.0024 = 7.60 \times 10^{-3}$$

$$[Acid]_{org} = \left(\frac{1000}{50.0} \times 7.60 \times 10^{-3} \right) \text{mol dm}^{-3} = 0.152 \text{mol dm}^{-3}$$

(b) Hence, the partition coefficient for propanoic acid distributed between the organic solvent and water is given by

$$\text{Partition coefficient} = \frac{[acid]_{org}}{[acid]_{aq}} = \frac{0.153}{0.0240} = 6.33$$

(c) Partition coefficient (KD).

Answers to checking up 7.1 :

1. The distribution constant, K_D is given by

$$K_D = \frac{(X)_A}{(X)_B} = 8$$

The solubility of X in B is given by

$$(X)_B = \frac{(X)_A}{K_D}$$

$$(X)_B = \frac{4.2}{8}$$

$$(X)_B = 0.525 \text{ mol dm}^{-3}$$

Thus the solubility of B is $0.525 \text{ mol dm}^{-3}$

2. The ratio of the concentration of iodine in carbon disulphide and water from the above results are

$$\frac{41}{0.1} = 410.0$$

$$\frac{66}{0.161} = 409.3$$

$$\frac{129}{0.314} = 410.8$$

$$\frac{174}{0.423} = 411.1$$

These values are almost constant and hence the distribution constant is approximately equal to 410. The constancy of the ratio indicates that iodine dissolves in both the solvents without any change in its molecular state.

Lesson 2: Raoult's law

a. Prerequisites/Revision/Introduction:

Students will learn well this lesson if they have knowledge and skills about Unit 4: Covalent bond and molecular structures especially intermolecular forces covered in senior four, nomenclature of organic compounds in Unit1, Unit11: Solutions and titration, Unit 14: Enthalpy change of reactions covered in senior five and Dalton's law of partial pressures covered in Physics O-Level.

b. Teaching resources

Use worksheet papers or books

c. Learning activities

This lesson starts by doing the activity 7.2 (a) and this activity can be performed by every student easily because of prerequisites they have. The activity is done in groups. Make sure that each student participates.

Methodological steps:

As a facilitator, you are expected to guide students to learn by doing activity 7.2 (a):

Answers of activity 7.2 (a):

1. The pressure exerted by the gas in equilibrium with a solid or liquid in a closed container at a given temperature is called the vapour pressure.
2. The vapour pressure increases in the following order: the vapour pressure of nonvolatile and pure solvent followed by the vapour pressure of pure solvent finally the vapour pressure of volatile solute and pure solvent. The vapour pressure exerted by a solution of nonvolatile solute and solvent is less than that of pure solvent due to the reduction of the surface area of the solvent particles; the vapour pressure of volatile solute and pure solvent is the sum of the vapour pressure exerted by pure solvent and that exerted by volatile solute.

Answers to Checking up 7.2 (a)

Answer:

$$1. \chi_{\text{solvent}} = 1.0000 - 0.1000 = 0.9000$$

$$P_{\text{solution}} = (\chi_{\text{solvent}})(P_{\text{solvent}}^{\circ})$$

Use Raoult's Law: $P_{\text{solution}} = 0.9000 \times 25.756$

$$P_{\text{solution}} = 23.18 \text{ mm Hg (to four significant figures)}$$

2. Use Raoult's Law:

$$P_{\text{solution}} = (\chi_{\text{solvent}})(P_{\text{solvent}}^{\circ})$$

$$24.90 = (\chi_{\text{solvent}}) \times 25.756 \Rightarrow \chi_{\text{solvent}} = 0.999765$$

$$\chi_{\text{solute}} = 1 - 0.999765 = 0.000235$$

$$\chi_{\text{solute}} = 0.000235 \text{ (to four significant figures)}$$

We will assume that B does not ionize in solution

Determine mole fraction of solvent that produces a solution of vapour

$$P_{\text{solution}} = \chi_{\text{solvent}} \times P_{\text{solvent}}^{\circ}$$

pressure of 23.756 torr: $23.756 \text{ torr} = \chi_{\text{solvent}} \times 42.362 \text{ torr}$

$$\chi_{\text{solvent}} = \frac{23.756 \text{ torr}}{42.362 \text{ torr}} = 0.5608$$

Determine moles of compound B needed to produce the above solvent

$$\begin{aligned} \text{mole fraction: it is known that } \chi_A &= \frac{n_A}{n_A + n_B}, \text{ thus} & 0.5608 &= \frac{13.88}{13.88 + n_B} \\ & & 0.5608 \times (13.88 + n_B) &= 13.88 \\ & & 7.7839 + 0.5608n_B &= 13.88 \\ & & n_B &= \frac{13.88 - 7.7839}{0.5608} = 10.870 \end{aligned}$$

3. Determine mass of B

$n = \frac{m}{Mm} \Rightarrow m = n \times Mm$ where n is number of moles, m is the mass and Mm the molar mass.

$$10.87 \text{ mol times } 97.80 \text{ g/mol} = 1063 \text{ g}$$

Comment: *this is a completely exaggerated amount to dissolve in 250.0 g of water; the point is to solve the problem.*

Use Raoult's Law to determine mole fraction of the solvent:

$$P_{\text{solution}} = \chi_{\text{solvent}} \times P_{\text{solvent}}^{\circ}$$

$$28.6 \text{ torr} = \chi_{\text{solvent}} \times 31.1 \text{ torr}$$

$$\chi_{\text{solvent}} = \frac{28.6 \text{ torr}}{31.1 \text{ torr}} = 0.91961415$$

4. Use the mole fraction and the moles of water to determine the moles of Y:

$$350.0 \text{ g} / 18.015 \text{ g/mol} = 19.428254 \text{ mol}$$

$$0.91961415 = \frac{19.428254}{19.428254 + n_Y} \Rightarrow n_Y = 1.69827 \text{ mol}$$

Calculate molar mass of Y:

$$86.8 \text{ g} / 1.69827 \text{ mol} = 51.1 \text{ g/mol (to three significant figures)}$$

5. Answer:

Convert the molality to a mole fraction. First, calculate total moles:

$$2.50 \text{ m C}_6\text{H}_{12}\text{O}_6 = 2.50 \text{ mol} / 1.00 \text{ kg H}_2\text{O}$$

$$1000 \text{ g} / 18.015 \text{ g/mol} = 55.51 \text{ mol (moles of water)}$$

$$55.51 \text{ mol} + 2.50 \text{ mol} = 58.01 \text{ mol (total number of moles)}$$

We need the mole fraction of water: $\chi_{\text{water}} = \frac{n_{\text{water}}}{n_{\text{water}} + n_{\text{solute}}}$

$$55.51 / 58.01 = 0.9569$$

Use Raoult's law equation:

$$P_{\text{solution}} = (\chi_{\text{solvent}}) (P^{\circ}_{\text{solvent}})$$

$$P_{\text{solution}} = (0.9569) (23.8 \text{ mmHg}) = 22.8 \text{ mmHg}$$

Answers to the activity 7.2 (a)

Raoult's law is obeyed by ideal solution; the ideal solutions are n-hexane and n-heptane solution and benzene and toluene solution; which are the solutions that obey Raoult's law. Others due to the intermolecular interactions they deviate the Raoult's law and they are called non ideal solutions. Non-ideal solutions have the vapour pressures greater or less than those predicted by Raoult's law.

Answers to checking up 7.2 (b)

Answer:

- (a) Solution of bromoethane and chloroethane will follow Raoult's law due to nearly same interactions between A-A, B-B and A-B. The solution formed will be nearly ideal.
(b) The solution of ethanol and acetone, and of chloroform and acetone deviate Raoult's law; with chloroform-acetone.
(c) The interactions between chloroform-acetone molecules are stronger than the interactions between chloroform-chloroform or acetone-acetone in the separated liquids. Hence the liquid cannot vaporize easily. The total vapour pressure for this solution is less than predicted by Raoult's law. In this case there is negative deviation. With ethanol- acetone: The bonds between ethanol- acetone molecules are weaker than the bonds between ethanol-ethanol or between acetone-acetone in the separate liquids. Thus, the liquid can vaporize more easily. In this case there is positive deviation.

Answer:

2. Solution is a

At specific composition methanol-acetone mixture will show positive deviation from Raoult's as it has lesser interactions than methanol-methanol and acetone-acetone interactions. Hence it forms minimum boiling azeotrope.

Answers to the Activity 7.2(c) :

1. Distillation is a method of separating mixtures based on differences in their volatility in boiling liquid mixture. The components must have different boiling points.
2. The illegal alcohol called Kanyanga is made by distillation. Try to explain how it is made.
3. Simple distillation is used when the boiling points of two liquids are significantly different from each other. In simple distillation a mixture is heated to change the most volatile component from a liquid into vapour. The vapour rises and passes into a condenser. The condenser is cooled, by running cold water around it to promote condensation of the vapour, which is collected. Fractional distillation separates the components of the mixture according to their boiling temperatures. Fractional distillation is used when the boiling points of the components of a mixture are closer to each other. In fractional distillation, a mixture is heated, so vapour rises and enters the fractionating column. As the vapour cools, it condenses on the packing material of the column. The heat of rising vapour causes this liquid to vaporise again, moving it along the column and eventually yielding a higher purity sample of the more volatile component of the mixture.

Answers to the Checking up 7.2(d):

The essential oils also called alkaloids are obtained from plants by steam distillation.

1. After 2-4 hours the steam distillation will be finished.
2. Turn the hot plate off and let the apparatus cool down. Remove the Separation funnel.
3. If essential oil which is heavier than water is in the bottom of the separating funnel collect it by carefully turning the stopcock and quickly closing the stopcock.
4. Drain away water collected in the Separation funnel.
5. If essential oil which is lighter than water is in the top of the separation funnel collect it.

N.B: it is important to open and close the stopcock quickly; otherwise essential oil may be lost

Answers to the Activity 7.2 (e)

They cured by the vapour released. The vapour released contained the essential oil having the curative properties. The method is called steam hydrodistillation.

Lesson 3: Colligative properties

a. Prerequisites/Revision/Introduction:

Students will learn well this lesson if they have knowledge and skills about Unit 11: solutions and titrations, Unit 1: introduction of organic chemistry: nomenclature of inorganic and organic compounds, types of formulae for chemical compounds and chemical energy change covered in senior five.

b. Teaching resources

Use books, projectors and/or chalkboard, laboratory and laboratory materials.

c. Learning activities

This lesson starts by doing the activity given and this activity can be performed by every student easily if they understood well the prerequisites listed above. The activity is done in groups. Make sure that each student participates.

Methodological steps:

As a facilitator, you are expected to guide students to learn by doing activity 7.3

Answers to the Activity 7.3:

1. A mixture of chemicals and water, antifreeze helps ensure that the liquid in our radiators doesn't freeze in the winter or boil over in the summer (overheating the engine), and in doing so, it protects our engines from damage. Although water is able to hold some of an engine's heat, most engines require a mixture of water and chemicals, more commonly known as coolant or antifreeze. This product is a crucial component of the cooling system, as it helps the car operate in a variety of temperatures, from the frigid cold to the scorching heat. Most of the time, the fluid is made of a combination of water and ethylene glycol ($C_2H_6O_2$). Pure water, as you may know, has a boiling point of $100^\circ C$ and a freezing point of $0^\circ C$. However, when you create a 50/50 mixture using water and ethylene glycol, the boiling point rises to $106^\circ C$ and the freezing point lowers to $-37^\circ C$. When you take it one step further, creating a 30/70 mixture of water and ethylene glycol, the boiling point rises to $113^\circ C$ and the freezing point lowers to $-55^\circ C$.

Boiling point elevation explains why you use antifreeze in your automobile's radiator in the summer. You want the engine to boil at a higher temperature so that it absorbs as much engine heat as possible without boiling. You also use a pressure cap on your radiator, because the higher the pressure, the higher the boiling point. This concept also explains why a pinch of salt in the cooking water causes foods to cook a little faster. The salt raises the boiling point so that the more energy can be transferred to cooking the food during a given amount of time.

Freezing point depression effect also explains why a salt (normally calcium chloride) is spread on ice to melt it. The dissolving of calcium chloride is highly exothermic. As the calcium chloride dissolves, it melts the ice and forms a solution in the resulting water. The salt solution that is formed when the ice formed has a lowered freezing point that keeps the solution from refreezing. Freezing point depression also explains the use of antifreeze in your cooling system during the winter.

2.a. This membrane is called a semipermeable membrane; it lets some small particles to pass through but not other, larger particles.

b. After a while, you observe that the level on the more concentrated side has risen, and the level on the more dilute side has dropped. This change in levels is due to the passage of water molecules from the more dilute to the more concentrated side through the semipermeable membrane.

c. This process is called osmosis, the passage of a solvent through a semipermeable membrane into a solution of higher solute concentration. The pressure you had to exert on the more concentrated side in order to stop this process is called the osmotic pressure of the solution. The more concentrated the salt solution, the more pressure it takes to stop the osmosis (the higher the osmotic pressure).

d. This process is shown in figure below.

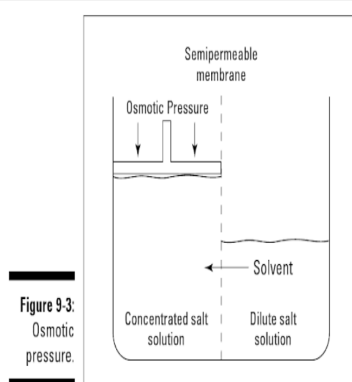

Figure: osmotic pressure

3.Expected answer see students' book.

Answer to Checking up 7.3

1. Osmotic pressure can be measured even at room temperature. ΔT_b , ΔT_f , and ΔP are very small values and cannot be measured accurately.

2.

$$P^\circ = 0.850 \text{ bar}$$

$$P = 0.845 \text{ bar}$$

$$W_B = 0.5 \text{ g}$$

$$W_A = 39.0 \text{ g}$$

$$M_B = ?$$

$$M_B = \frac{W_B M_A}{W_A \left(\frac{P^\circ - P}{P^\circ} \right)} = \frac{0.5 \times 78}{39.0 \times \left(\frac{0.850 - 0.845}{0.850} \right)} = 170 \text{ g mol}^{-1}$$

3.

$$P^\circ = 17.450 \text{ mm Hg}, W_B = 25 \text{ g}$$

$$M_B = 180 \text{ g mol}^{-1}$$

$$W_A = 450 \text{ g}$$

$$\frac{P^\circ - P}{P^\circ} = \chi_B = \frac{W_B / M_B}{\frac{W_B}{M_B} + \frac{W_A}{M_A}} = \frac{25/180}{\frac{25}{180} + \frac{450}{18}} = 5.53 \times 10^{-3}$$

$$1 - \frac{P}{P^\circ} = 5.53 \times 10^{-3} \Rightarrow P = (1 - 5.53 \times 10^{-3}) P^\circ = 17.438 \text{ mm Hg}$$

4.

Freezing point of C = 198.5°C

Freezing point of solution = 186°C

$$\Rightarrow \Delta T_f = 198.5^\circ \text{C} - 186^\circ \text{C} = 12.5^\circ \text{C}$$

$$m = 45.5^\circ \text{C} / m$$

Formula to find molar mass

$$M_A = \frac{1000 \times K_f \times W_A}{W_C \times \Delta T_f}$$

$$M_A = \frac{1000 \times 45.5 \times 0.049}{0.521 \times 12.5} = 342.3$$

5. A liquid boils when its vapour pressure is equal to the atmospheric pressure. When the atmospheric pressure is reduced, few water molecules are needed to escape into the vapour phase and make up a vapour pressure equal to this low atmospheric pressure. Less heat energy (lower boiling point) is therefore required to vaporize these water molecules.

7.6 Summary of the Unit

When a solute, at constant temperature, is added to two immiscible solvents in contact with each other, the solute gets distributed between the two solvents with different equilibrium concentrations. If C_A and C_B are the concentrations of solute in water and

organic solvent, then, $\frac{C_A}{C_B} = K_D$. The constant K_D is called the **distribution coefficient** of

the solute between the two solvents at given temperature. The Nernst Distribution Law states that at constant temperature, when different quantities of a solute are allowed to distribute between two immiscible solvents in contact with each other then at equilibrium the ratio of the concentration of the solute in two layers is constant. The Nernst Distribution Law holds of for ideal solutions. The solvent extraction is one of the applications of partition coefficient. The vapour pressure of the solvent is lowered by the presence of nonvolatile solute in the solution and this lowering pressure is governed by Raoult's law.

Raoult's law states that "for a solution of volatile liquids, the partial vapour pressure of each component of the solution is directly proportional to its mole fraction present in solution". The solutions which are perfectly ideal follow the Raoult's law perfectly and non ideal solutions deviate from Raoult's law. Depending on the interactions between solute-solute, solute-solvent and solvent-solvent, there are negative and positive deviations from Raoult's law.

There are many binary solutions of two volatile liquids which at a definite composition behave like pure liquids because their vapours have the same composition of the components as in the solution. Such solutions are called Azeotropes.

A physical property of a solution that depends on the concentration of solute particles present, regardless of the nature of the solute, is called a colligative property. Colligative properties include relative vapour pressure lowering, freezing point lowering, boiling point elevation, and osmotic pressure.

Colligative properties of non-electrolyte solutions provide a means of determination of molar masses and molecular formula of dissolved solutes which are non volatile.

7.7 Additional information for teacher

Solvent extraction is the partial removal of a molecular solute from one liquid (usually water) into another immiscible liquid (e.g. ether). This is a method of separating one component from a mixture. Solvent extraction is more efficient if the extracting solvent is used in several portions and separated after each extraction. Thus, if the availability of the solvent (say, ether) is limited, continuous extraction may be used to extract as much compound as possible.

The process of extraction when carried out with the total amount of the given solvent in a single operation is referred to as **simple extraction**. But to recover the maximum amount of the substance from aqueous solution, the extraction is made in two or

more successive operations using small portions of the solvent provided. This is called **multiple extractions**.

In the student book, we have an activity on multiple extractions, but there is no general formula for multiple extractions to find substance left unextracted during solvent extraction. Here, you have the demonstration of the general formula for multiple extractions.

General Formula for Substance Left Unextracted during solvent extraction

Suppose **V ml** of an aqueous solution contain **A** grams of an organic substance. This solution is extracted with **v ml** of the given organic solvent at a time.

- **First extraction.**

x_1 : The substance left unextracted in aqueous solution in the first operation.

$$\text{Concentration in aqueous layer} = \frac{x_1}{V}$$

$$\text{Concentration in solvent} = \frac{A - x_1}{v}$$

$$K = \frac{x_1/V}{(A - x_1)/v} = \frac{x_1}{V} \times \frac{v}{(A - x_1)}$$

$$\Rightarrow K V (A - x_1) = x_1 v$$

$$K V A - K V x_1 = x_1 v$$

$$\Rightarrow x_1 v + K V x_1 = K V A$$

$$\Rightarrow x_1 (K V + v) = K V A$$

$$\Rightarrow x_1 = A \frac{K V}{K V + v} \quad (1)$$

- **Second extraction.**

x_2 : The substance left unextracted in the aqueous layer in the second extraction made with fresh **v ml** solvent.

$$\text{Concentration in aqueous layer} = \frac{x_2}{V}$$

$$\text{Concentration in solvent} = \frac{x_1 - x_2}{v}$$

$$K = \frac{x_2 / V}{(x_1 - x_2) / v}$$

$$\Rightarrow K = \frac{x_2}{V} \times \frac{v}{x_1 - x_2}$$

$$\Rightarrow KV(x_1 - x_2) = x_2v$$

$$\Rightarrow KVx_1 - KVx_2 = x_2v$$

$$\Rightarrow KVx_1 = x_2v + KVx_2$$

$$\Rightarrow KVx_1 = x_2(KV + v)$$

$$\Rightarrow x_2 = x_1 \frac{KV}{KV + v}$$

Substituting the value of x_1 from the equation (1)

$$x_2 = A \frac{KV}{KV + v} \times \frac{KV}{KV + v}$$

$$x_2 = A \left(\frac{KV}{KV + v} \right)^2 \quad (2)$$

- **n-th extraction.**

Following the above procedures for first and second extraction, the amount of substance left unextracted (X_n) in the n-th extraction would be $x_n = A \left(\frac{KV}{KV + v} \right)^n$ (3)

This general formula enables the calculation of the amount of substance left unextracted after a specified number of extractions with v ml portion of the solvent each time.

- **Extraction with whole lot of solvent.**

If the entire quantity of the given solvent is used for a single extraction, the amount of substance unextracted (x') would be $x' = A \left(\frac{KV}{KV + v} \right)$ (4)

Since the quantity within the bracket is less than unity, x_n is smaller than x' . Also, x_n will be smaller the greater the value of n . Hence it is more economical to use the solvent in small portions in a number of extractions.

Colligative properties of electrolyte solutions

Strong electrolytes are compounds which dissociate completely into two or more ions when dissolved in water. Each ion acts as discrete particle as far as the colligative properties are concerned.

The study of colligative properties of electrolytes requires a slightly different approach than the one used for the colligative properties of non electrolytes. The reason is that

electrolytes dissociate into ions in solution and so one unit of an electrolyte compound separates into two or more particles when it dissolves. To account to this effect we define a quantity called Van't Hoff factor, given by

$$i = \frac{\text{Actual number of particles in solution after dissociation}}{\text{number of formula unit initially dissolved in solution}}$$

Thus, i should be one for all non electrolytes. For strong electrolytes such as NaCl and KNO_3 , i should be 2 and for strong electrolytes such as Na_2SO_4 and CaCl_2 , i should be three.



Consequently, the question for colligative properties must be modified as

$$\Delta T_b = i K_b m$$

$$\Delta T_f = i K_f m$$

$$\pi = i MRT$$

Example:

Example:

1. If 152 g of sodium sulfate are dissolved in 875 g of water, what will be the boiling point of the resulting solution? Assume 100% ionization.

Answer:

Mass of solute= 152 g

Mass of solvent= 875g

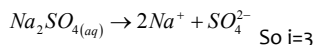

$$Mm_{\text{Na}_2\text{SO}_4} = 142 \text{ g mol}^{-1}$$

$$n_{\text{solute}} = \frac{m}{Mm} = \frac{152 \text{ g}}{142 \text{ g/mol}} = 1.07 \text{ mol}$$

$$K_b = 0.52^\circ\text{C}/m = 0.52^\circ\text{C}/\text{mol kg}^{-1} = 0.52^\circ\text{C Kg/mol}$$

$$\Delta T_b = i K_b m$$

$$\Delta T_b = i K_b \frac{m_{\text{solute}}}{Mm_{\text{solute}} \times m_{\text{solvent}}}$$

$$\Delta T_b = 3 \times 0.52^\circ\text{C Kg/mol} \times \frac{152 \text{ g}}{142 \text{ g/mol} \times 875 \times 10^{-3} \text{ Kg}}$$

$$\Delta T_b = 1.91^\circ\text{C}$$

The boiling point of resulting solution = $1.91^\circ\text{C} + 100^\circ\text{C} = 101.91^\circ\text{C}$

2. What will be the freezing point and boiling point of solution 150.0 g of NaCl and 300.0 g of diethyl ether?

Boiling point of ether = 34.6°C
Freezing point of ether = -116.3°C

$K_b(\text{ether}) = 2.02^{\circ}\text{C}/m$
 $K_f(\text{ether}) = 1.79^{\circ}\text{C}/m$

Answer:

$m_{\text{NaCl}} = 150\text{g}$
 $Mm_{\text{NaCl}} = 58.5\text{g/mol}$

Diethyl ether is solvent

$m_{\text{solvent}} = 300\text{g} = 0.3\text{Kg}$
 $K_b = 2.02^{\circ}\text{C}/m$

$\text{NaCl} \rightarrow \text{Na}^+ + \text{Cl}^-$ $i = 2$

$$\Rightarrow \Delta T_b = i K_b m \qquad m = \frac{2.56\text{mol}}{0.3\text{Kg}} = 8.533\text{mol/Kg}$$

$$\Delta T_b = 2 \times 2.02^{\circ}\text{C/mol} \times 8.533\text{mol} = 34.5^{\circ}\text{C}$$

Boiling point of solution = $\Delta T_b + b.p(\text{ether}) = 34.5^{\circ}\text{C} + 34.6^{\circ}\text{C} = 69.1^{\circ}\text{C}$

$$\Rightarrow \Delta T_f = i K_f m$$

$$\Delta T_f = 2 \times 1.79^{\circ}\text{C}/m \times 8.533m = 30.55^{\circ}\text{C}$$

$$\Delta T_f = T_{\text{ether}} - T_{\text{solution}} \Rightarrow T_{\text{solution}} = T_{\text{ether}} - \Delta T_f$$

$$T_{\text{solution}} = -116.3^{\circ}\text{C} - 30.55^{\circ}\text{C} = -146.83^{\circ}\text{C}$$

7.8 Answers to end unit Assessment

Answers to end unit assessment questions

- (a,b)** Colligative properties are observed when a non-volatile solid or liquid is dissolved in a volatile liquid.
- (b,c)** Non-ideal solution mixtures with same composition in liquid and vapour phase are azeotropes. Water-nitric acid has maximum boiling azeotrope and water-ethanol has a minimum boiling azeotrope.
- (a)** Mixture of methanol and acetone shows positive deviation because methanol-methanol and acetone-acetone interactions are more than methanol-acetone. The more number of hydrogen bonds are broken, the less number of new H-bonds are formed.
- (a,b)** Relative lowering of vapour pressure depends on concentration of non-electrolyte solute in solution and number of particles of electrolyte solute. It does not depend on nature of solute in both conditions.
- d** If A-B interactions < A-A or B-B the vapour pressure will be more and the result will be positive deviation. The solutions which show positive deviation form minimum boiling azeotropes.
- b** Colligative properties depend upon the number of solute particles in the solution and independent of its nature.

$$7. \quad 4.6 = \frac{x/40\text{mLCH}_2\text{Cl}_2}{(0.5-x)/100\text{mL H}_2\text{O}}$$

$$4.6 = \frac{\frac{x}{40}}{(0.5-x)} \Rightarrow 4.6 = \frac{x}{40} \times \frac{100}{0.5-x}$$

$$\frac{4.6 \times 40}{100} = \frac{x}{(0.5-x)} \Rightarrow 1.84 = \frac{x}{(0.5-x)}$$

$$1.84(0.5-x) = x \Rightarrow 0.92 - 1.84x = x$$

$$0.92 = x + 1.84x \Rightarrow 0.92 = 2.84x$$

$$x = \frac{0.92}{2.84} \Rightarrow x = 0.3239$$

The mass of caffeine extracted is 0.3239 g

% of caffeine extracted

$$\frac{0.3239\text{g}}{0.500\text{g}} \times 100 = 64.78\% \text{Caffeine extracted}$$

1st extraction

$$1.87 = \frac{x/20\text{ mL Octanol}}{(1-x)/100\text{ mL H}_2\text{O}} \Rightarrow 1.87 = \frac{\frac{x}{20}}{\frac{1-x}{100}} \Rightarrow 1.87 = \frac{x}{20} \times \frac{100}{1-x}$$

$$\frac{1.87 \times 20}{100} = \frac{x}{1-x} \Rightarrow 0.374 = \frac{x}{1-x} \Rightarrow 0.374(1-x) = x$$

$$0.374 - 0.374x = x \Rightarrow 0.374 = 1.374x \Rightarrow x = \frac{0.374}{1.374} \Rightarrow x = 0.2722$$

The mass of benzoic acid extracted is 0.2722 g, so 0.7278 g remains.

$$\frac{0.2722\text{g}}{1\text{g}} \times 100 = 27.22\% \text{Benzoic acid extracted}$$

2nd extraction

$$1.87 = \frac{x/20\text{ mL Octanol}}{(0.7278-x)/100\text{ mL H}_2\text{O}} \Rightarrow 1.87 = \frac{\frac{x}{20}}{\frac{0.7278-x}{100}} \Rightarrow 1.87 = \frac{x}{20} \times \frac{100}{0.7278-x}$$

$$\frac{1.87 \times 20}{100} = \frac{x}{0.7278-x} \Rightarrow 0.374 = \frac{x}{0.7278-x} \Rightarrow 0.374(0.7278-x) = x$$

$$0.2722 - 0.374x = x \Rightarrow 0.2722 = 1.374x \Rightarrow x = \frac{0.2722}{1.374} \Rightarrow x = 0.1981$$

The mass of benzoic acid extracted is 0.1981 g, so 0.5297 g remains.

Total mass extracted = 0.2722g + 0.1981g = 0.4703g

$$\frac{0.4703}{1} \times 100 = 47.03\% \text{Benzoic acid extracted}$$

3rd extraction

$$1.87 = \frac{x / 20 \text{ mL Octanol}}{(0.5297 - x) / 100 \text{ mL H}_2\text{O}} \Rightarrow 1.87 = \frac{\frac{x}{20}}{0.5297 - x} \Rightarrow 1.87 = \frac{x}{20} \times \frac{100}{0.5297 - x}$$

$$\frac{1.87 \times 20}{100} = \frac{x}{0.5297 - x} \Rightarrow 0.374 = \frac{x}{0.5297 - x} \Rightarrow 0.374(0.5297 - x) = x$$

$$0.1981 - 0.374x = x \Rightarrow 0.1981 = 1.374x \Rightarrow x = \frac{0.1981}{1.374} \Rightarrow x = 0.1442 \text{ g Benzoic acid}$$

8. The mass of benzoic acid extracted is 0.1442 g, so 0.3855 g.

The total mass extracted = 0.2722g + 0.1981g + 0.1442g = 0.6145g

$$\frac{0.6145}{1} \times 100 = 61.45\% \text{ Benzoic acid;}$$

percentage of benzoic extracted is 61.45%

9.

8

$$P = \frac{0.042 \text{ g} / 25 \text{ mL ether}}{(0.100 - 0.042) \text{ g} / 100 \text{ mL H}_2\text{O}} = 2.897$$

7 Use the equation: $\Delta T = K_f m_{\text{solute}}$

$$\Delta T = K_f m_{\text{solute}} \Rightarrow m_{\text{solute}} = \frac{\Delta T}{K_f} = \frac{23.3^\circ \text{C}}{1.86^\circ \text{C} \cdot \text{kg} / \text{mol}} = 12.5 \text{ mol} / \text{kg}$$

This means that 12.5 mol ethylene glycol must be added per kg of water. We have 10.0l, or 10.0 kg of water. Therefore, the total number of moles of ethylene glycol needed is

$$\frac{12.5 \text{ mol}}{1 \text{ kg}} \times 10.0 \text{ kg} = 1.25 \times 10^2 \text{ mol}$$

$$\text{The mass of ethylene glycol needed is } \frac{12.5 \text{ mol}}{\text{kg}} \times \frac{62.1 \text{ g}}{\text{mol}} = 7.76 \times 10^3 \text{ g}$$

8 The molality of the hormone is

$$m_{\text{hormone}} = \frac{\Delta T}{K_f} = \frac{0.240^\circ \text{C}}{5.12^\circ \text{C} \cdot \text{Kg} / \text{mol}} = 4.69 \times 10^{-2} \text{ mol} / \text{kg}$$

The moles of hormone can be obtained from the definition of molality:

$$4.69 \times 10^{-2} \text{ mol} / \text{Kg} = m_{\text{solute}} = \frac{\text{mol hormone}}{0.0150 \text{ Kg benzene}}$$

$$\text{mol hormone} = (4.69 \times 10^{-2} \text{ mol} / \text{K})(0.0150 \text{ Kg benzene}) = 7.04 \times 10^{-4} \text{ mol}$$

Since 0.546 g hormone was dissolved, 7.04×10^{-4} mol hormone has a mass of 0.546 g and

$$\frac{0.546\text{g}}{7.04 \times 10^{-4}\text{mol}} = \frac{x\text{g}}{1.00\text{mol}} \Rightarrow x = 776\text{g/mol}$$

Thus the molar mass of the hormone is 776g/mol.

9 We use the equation: $\pi = MRT$. In this case we have:

$$\pi = 1.12\text{torr} \times \frac{1\text{atm}}{760\text{torr}} = 1.47 \times 10^{-3}\text{atm} \quad \text{where} \quad R = 0.08206\text{L.atm/K.mol}$$

$$T = 25.0 + 273 = 298\text{K}$$

Note that the osmotic pressure must be converted to atmospheres because of the units of R.

Solving for M gives

$$M = \frac{1.47 \times 10^{-3}\text{atm}}{(0.08206\text{L.atm/K.mol}) \times (298\text{K})} = 6.01 \times 10^{-5}\text{mol/L}$$

The molar mass of the protein is 1.66×10^4 . This mass may seem very large, but it is relatively small for a protein.

10. Molecular masses of polymers are best determined by osmotic pressure method. Firstly because other colligative properties give so low values that they cannot be measured accurately and secondly, osmotic pressure measurements can be made at room temperature and do not require heating which may change the nature of the polymer.

11. A solution which obeys Raoult's law at all concentrations and at all temperatures is called an ideal solution. For non-ideal solutions, vapour pressure is either higher or lower than that predicted by Raoult's law. If it is higher, the solution exhibits positive deviation and if it is lower, it exhibits negative deviation from Raoult's law $\Delta V_{\text{mix}} = 0; \Delta H_{\text{mix}} = 0$.

Positive deviation is shown when the forces of attraction between A-B molecules are less than forces of attraction between A-A and B-B molecules in the two liquids forming the solution.

Example, ethanol+ acetone and carbon disulphide+acetone show positive deviation.

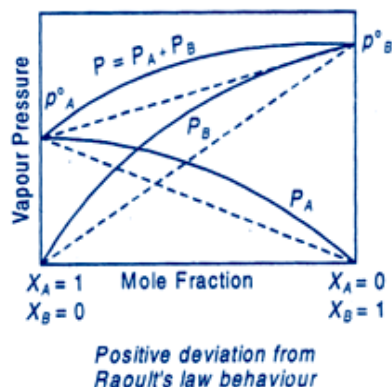

Negative deviation is shown when A-B interactions are stronger than the A-A and B-B

molecular interactions present in the two liquids forming the solution.

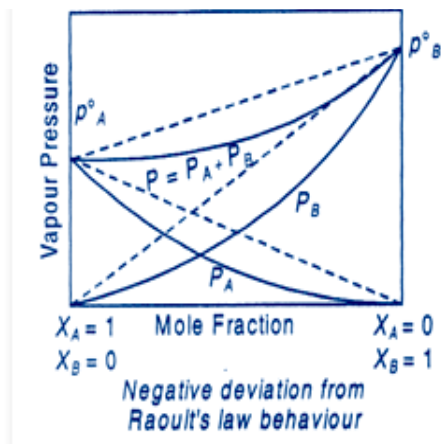

Example, phenol + aniline and chloroform+ acetone show negative deviation.

7.9. Additional Activities

Remedial Questions

1. What is meant by reverse osmosis?
2. Explain boiling point elevation constant for a solvent or ebullioscopic constant.
3. Some liquids on mixing form 'azeotropes'. What are 'azeotropes'?
4. What type of intermolecular attractive interaction exists in the pair of methanol and acetone?
5. Two liquids A and B are mixed. The resulting solution is found to be cooler. What do you conclude?

Answer:

1. If a pressure higher than osmotic pressure is applied on the solution, the solvent will flow from the solution into the pure solvent through the semipermeable membrane. Since here the flow of solvent is in the reverse direction to that observed in the usual osmosis, the process is called reverse osmosis.
2. We know that, $\frac{\Delta T_b}{m} = K_b$, thus, boiling point elevation constant is equal to the elevation in boiling point when 1 mole of solute is dissolved in 1 kg of solvent. It is also called ebullioscopic constant.
when, $m=1, \Delta T_b = K_b$.
3. A liquid mixture having a definite composition and boiling like a pure liquid is called an azeotrope.
4. Both methanol and acetone are polar molecules. Hence intermolecular interactions in them are dipole-dipole interactions.
5. The solution shows a positive deviation.

Consolidation Questions

1. Why constant boiling mixtures behave like a single component when subjected to distillation?
2. What are the colligative properties?
3. Mole of acetic acid was dissolved 1 kg of benzene. Depression in freezing point of benzene was determined to be 0.256 K. what conclusion can you draw about the state of the solute in solution [Given, K_f for benzene = 5.12 K m^{-1}]
4. 2g each of the solutes A and B (Mol. Mass of A > B) are dissolved separately in 20g each of the same solvent C. Which will show greater lowering of vapour pressure and why?
5. Find the boiling point of a solution containing 0.520 g of glucose ($C_6H_{12}O_6$) dissolved in 80.2 g of water. ($K_b = 0.52 \text{ K/m}$)
6. A solution prepared by dissolving 1.25 g of oil of winter green (methyl salicylate) in 99.0 g of benzene has a boiling point of 80.31°C . Determine the molar mass of this compound. (Given: B.P of benzene = 80.10°C ; K_b for benzene = $2.35^\circ\text{C Kg mol}^{-1}$)
7. Explain why a solution of chloroform and acetone shows negative deviation from Raoult's law?
8. What would be the molar mass of a compound if 6.21 g of it dissolved in 24.0 g of chloroform form a solution that has a boiling point of 68.04°C ? The boiling point of pure chloroform is 61.7°C and the boiling point elevation constant, K_b for chloroform is 3.63°C/m .
9. 18 g of glucose, $C_6H_{12}O_6$ (molar mass = 180 g mol^{-1}), is dissolved in 1 kg of water in a sauce pan. At what temperature will this solution boil? (K_b for water = $0.52 \text{ K Kg mol}^{-1}$, boiling point of pure water = 373.15 K)

Answer

1. Composition of Azeotropic mixture (liquid pairs) vaporizes without change in composition; the liquid obtained by the condensation of the vapour also has same composition i.e. the mixture distils over as if it were a pure liquid. Azeotropic mixtures cannot be separated into their constituents by fractional distillation.
2. The important colligative properties are:
 - i. Relative lowering of vapour pressure
 - ii. Elevation in boiling point
 - iii. Depression in freezing point
 - iv. Osmotic pressure

3. No. of moles of $\text{CH}_3\text{COOH} = \frac{\text{mass of } \text{CH}_3\text{COOH}}{\text{molar mass of } \text{CH}_3\text{COOH}}$

$$\text{mass of } \text{CH}_3\text{COOH} = 0.1 \times 60 = 6 \text{ g}$$

$$\text{given, } W_1 = 1 \text{ Kg} = 1000 \text{ g (benzene)}$$

$$\Delta T_f = 0.256 \text{ K, } K_f = 5.12 \text{ K m}^{-1}$$

4. B will show greater lowering of vapour pressure because $\frac{P^\circ - P_s}{P^\circ} = \frac{W_2 \times M_1}{W_1 \times M_2}$. Here,

lowering of vapour pressure ($P^\circ - P_s$) is directly related with amount in gram and inversely related with molar mass of non-volatile solute.

5. Mass of glucose (W_B) = 0.520 g and Molar mass of glucose (M_B) = 180 g/mol

Mass of water (W_A) = 80.2 g and Molar mass of water (M_A) = 18 g/mol

K_b = 0.52 K/m

Formula:

$$\Delta T_b = K_b \frac{W_B \times 1000}{M_B \times W_A}$$

$$\Delta T_b = 0.52 \frac{0.520 \times 1000}{180 \times 80.2} = 0.02$$

The boiling of water is 100°C; $\Delta T_b = T_{\text{water}} - T_{\text{solution}}$

$$T_{\text{solution}} = T_{\text{water}} - \Delta T_b$$

$$T_{\text{solution}} = 100^\circ\text{C} - 0.02^\circ\text{C} = 99.98^\circ\text{C}$$

The boiling point of solution is 99.98°C

6. **Given:**

$$W_2 = 1.25 \text{ g}, W_1 = 99.0 \text{ g}, T_b = 80.31^\circ\text{C},$$

$$T_b^\circ = 80.10^\circ\text{C}, K_b = 2.35^\circ\text{C Kg mol}^{-1}$$

Using formula,

$$\Delta T_b = K_b m = K_b \times \frac{W_2}{M_2} \times \frac{1000}{W_1}$$

$$T_b - T_b^\circ = K_b \times \frac{W_2}{M_2} \times \frac{1000}{W_1}$$

$$\Rightarrow M_2 = \frac{K_b \times W_2 \times 1000}{(T_b - T_b^\circ) W_1} = \frac{2.35 \times 1.25 \times 1000}{(80.31 - 80.10) \times 99}$$

$$M_2 = \frac{3162.5}{20.79} = 152.11 \approx 152 \text{ g mol}^{-1}$$

7. As a result of intermolecular H-bonding between O-atom of $(\text{CH}_3)_2\text{CO}$ and H-atom of CHCl_3 , A-B interaction becomes stronger than A-A and B-B interactions. This leads to the decrease in vapour pressure and results in negative deviation.

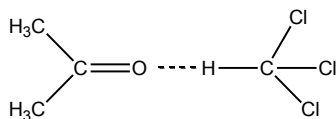

8. Given,

$$W_2 \text{ (unknown compound)} = 6.21\text{g}$$

$$W_1(\text{CHCl}_3) = 24.0\text{g}$$

$$T_b \text{ (b.p of solution)} = 68.04^\circ\text{C}$$

$$T_b \text{ (b.p of pure CHCl}_3) = 61.7^\circ\text{C and } K_b = 3.63^\circ\text{C/m}$$

Elevation in boiling point

$$\Delta T_b = \frac{K_b \times W_2 \times 1000}{M_2 \times W_1} \text{ or } M_2 = \frac{K_b \times W_2 \times 1000}{\Delta T_b \times W_1}$$

$$(\Delta T_b = T_b - T_b^\circ = 68.04^\circ\text{C} - 61.7^\circ\text{C} = 6.34^\circ\text{C})$$

$$M_2 = \frac{3.63^\circ\text{Cm}^{-1} \times 6.21\text{g} \times 1000}{6.34^\circ\text{C} \times 24.0\text{g}} = 148.15 \text{ g mol}^{-1}$$

9. Given,

$$W_2 = 18 \text{ g}; M_2 = 180 \text{ g mol}^{-1}; W_1 = 1 \text{ kg} = 1000\text{g}$$

$$K_b = 0.52 \text{ K Kg mol}^{-1}$$

$$\Delta T_b = K_b \times \frac{W_2}{M_2} \times \frac{1000}{W_1} = 0.52 \times \frac{18}{180} \times \frac{1000}{1000} = 0.052 \text{ K}$$

$$\text{Now, } \Delta T_b = T_s - T^0 \Rightarrow 0.052 = T_s - 373.15 \\ \Rightarrow T_s = 373.15 + 0.052 = 373.20 \text{ K}$$

Boiling point of solution = 373.20 K.

Extended Questions

1. Benzene, C_6H_6 (*b.p.* 353.1 K) and toluene, C_7H_8 (*b.p.* 383.6 K) are two hydrocarbons that form a very nearly ideal solution. At 313 K, the vapour pressure pure liquids are, benzene, 160 mm Hg; toluene, 60 mm Hg. Assuming an ideal solution behavior, calculate the partial pressures of benzene and toluene, and the total pressure over the following solutions:

- (i) One made by combining equal numbers of toluene and benzene molecules.
(ii) One made by combining 4 moles of toluene with 1 mole of benzene.
(iii) One made by combining equal masses of toluene and benzene.

Answer:

Given,

Vapour pressure of benzene at 313 K, $P_b^{\circ} = 160$ mm Hg

Vapour pressure of toluene at 313 K, $P_t^{\circ} = 60$ mm Hg

- (i) For a mixture containing equal number of toluene and benzene molecules, i.e., if N_t and N_b are the numbers of molecules of toluene and benzene respectively. Then,

mole fraction of benzene, $\chi_b = \frac{N_b}{N_b + N_t}$ and mole fraction of toluene, $\chi_t = \frac{N_t}{N_b + N_t}$

Since, $N_t = N_b$

Hence, $\chi_b = \frac{N_b}{N_b + N_b} = 0.5$ and $\chi_t = \frac{N_t}{N_t + N_t} = 0.5$

According to Raoult's law:

Partial pressure of benzene, $P_b = P_b^{\circ} \chi_b = 160 \text{ mm Hg} \times 0.5 = 80 \text{ mm Hg}$

Partial pressure of toluene, $P_t = P_t^{\circ} \chi_t = 60 \text{ mm Hg} \times 0.5 = 30 \text{ mm Hg}$

Therefore, total vapour pressure, $P = P_b + P_t = (80 + 30) \text{ mm Hg} = 110 \text{ mm Hg}$

- (ii) No. of moles of toluene = 4
No. of moles of benzene = 1

Therefore,

mole fraction of benzene, $\chi_b = \frac{1}{1+4} = 0.2$ and mole fraction of toluene, $\chi_t = \frac{4}{1+4} = 0.8$

Then,

Partial pressure of toluene, $P_t = 60 \times 0.8 = 48 \text{ mm Hg}$

Partial pressure of benzene, $P_b = 160 \times 0.2 = 32 \text{ mm Hg}$

Total vapour pressure, $P_t = 48 \text{ mm Hg} + 32 \text{ mm Hg} = 80 \text{ mm Hg}$

- (iii) Let, W gram of each are mixed to prepare a solution. Then,

No. of moles of benzene, $n_b = \frac{\text{Mass of benzene}}{\text{Molar mass of benzene}} = \frac{W \text{ g}}{78 \text{ g mol}^{-1}}$

No. of moles of toluene, $n_t = \frac{\text{Mass of toluene}}{\text{Molar mass of toluene}} = \frac{W \text{ g}}{92 \text{ g mol}^{-1}}$

Therefore,

$$\text{Total no. of moles } Total \text{ no. of moles} = n_b + n_t = \frac{W}{78} + \frac{w}{92} = \frac{(92+78)W}{78 \times 92} = \frac{170 \times W}{78 \times 92}$$

$$\text{Then, Mole fraction of benzene, } \chi_b = \frac{n_b}{n_b + n_t} = \frac{\frac{W}{78}}{\frac{W \times 170}{(78 \times 92)}} = \frac{W}{78} \times \frac{(78 \times 92)}{W \times 170} = 0.54$$

$$\text{Similarly, Mole fraction of toluene, } \chi_t = \frac{n_t}{n_b + n_t} = \frac{\frac{W}{92}}{\frac{W \times 170}{(78 \times 92)}} = \frac{W}{92} \times \frac{(78 \times 92)}{W \times 170} = 0.46$$

Therefore,

$$\text{Partial pressure of benzene, } P_b = P_b^\circ \chi_b = 160 \times 0.54 \text{ mm Hg} = 86.4 \text{ mm Hg}$$

$$\text{Partial pressure of toluene, } P_t = P_t^\circ \chi_t = 60 \times 0.46 \text{ mm Hg} = 27.6 \text{ mm Hg}$$

Then, Total vapour pressure, $(86.4 + 27.6) \text{ mm Hg} = 114.0 \text{ mm Hg}$

2. (a) What type of deviation (positive or negative) from ideal behaviour will be shown by the solution of cyclohexane and ethanol? Give suitable reason.
(b) Two liquids X and Y on mixing form an ideal solution. At 30°C, the vapour pressure of the solution containing 3 mol of X and 1 mol of Y is 550 mm Hg. But, when 4 mol of X and 1 mol of Y are mixed, the vapour pressure of the solution thus formed is 560 mm Hg. What would be vapour pressure of pure X and pure Y at this temperature?

Answer:

- (a) Solutions of cyclohexane and ethanol show positive deviations.

Explanation:

In pure ethanol, the molecules of ethanol are hydrogen bonded. When cyclohexane is added to it, the cyclohexane molecules get in between the molecules of ethanol, and break the hydrogen bonds. This decreases the ethanol-ethanol intermolecular attraction. Therefore, molecules of ethanol are able to escape into the vapour phase more easily. As a result, the system shows positive deviation.

- (b) Let P_X° and P_Y° be the vapour pressure of pure X and Y at 30°C. then, for an ideal solution,

$$P = P_X^\circ \chi_X + P_Y^\circ \chi_Y = P_X^\circ \times \frac{n_X}{n_X + n_Y} + P_Y^\circ \times \frac{n_Y}{n_X + n_Y}$$

Then, for

$$\text{Solution 1: } 550 = P_X^\circ \times \frac{3}{3+1} + P_Y^\circ \times \frac{1}{3+1} = P_X^\circ \times \frac{3}{4} + P_Y^\circ \times \frac{1}{4} \quad \text{K (i)}$$

$$\text{Solution 2: } 560 = P_X^\circ \times \frac{4}{4+1} + P_Y^\circ \times \frac{1}{4+1} = P_X^\circ \times \frac{4}{5} + P_Y^\circ \times \frac{1}{5} \quad \text{K (ii)}$$

Multiply (i) by 4 and (ii) by 5 $550 \times 4 = 3 P_X^\circ + P_Y^\circ$ K (iii)
 $560 \times 5 = 4 P_X^\circ + P_Y^\circ$ K (iv)

Subtracting (iii) from (iv) $P_X^\circ = (560 \times 5 - 550 \times 4) \text{ mm Hg} = 600 \text{ mm Hg}$

Substituting the value of P_X° in (iii),

one gets $P_Y^\circ = (550 \times 4 - 3 \times 600) \text{ mm Hg} = (2200 - 3 \times 600) \text{ mm Hg} = 400 \text{ mm Hg}$

So,

Vapour pressure of pure X at 30°C is 600 mm Hg

Vapour pressure of pure Y at 30°C is 400 mm Hg.

3. A solution containing 30 g of non-volatile solute exactly in 90 g of water has a vapour pressure of 2.8 kPa at 298 K. further 18 g of water is then added to solution, the new vapour pressure becomes 2.9 kPa at 298 K. calculate:
- Molecular mass of solute
 - Vapour pressure of water at 298 K.

Answer:

(i) Let the molecular mass of non-volatile solute = M_2

$$\frac{P^\circ - P_1}{P^\circ} = \frac{W_2 \times M_1}{W_1 \times M_2}$$

$$\frac{P^\circ - 2.8}{P^\circ} = \frac{30 \times 18}{90 \times M_2} = \frac{6}{M_2}$$

$$P^\circ - 2.8 = \frac{6P^\circ}{M_2}$$

$$P^\circ - \frac{6P^\circ}{M_2} = 2.8$$

$$P^\circ \left(1 - \frac{6}{M_2} \right) = 2.8$$

$$P^\circ \left(\frac{M_2 - 6}{M_2} \right) = 2.8 \quad \text{(i)}$$

After adding 18 g of water to solution

$$\frac{P^\circ - 2.9}{P^\circ} = \frac{30 \times 18}{108 \times M_2} = \frac{5}{M_2}$$

$$P^\circ - 2.9 = \frac{5P^\circ}{M_2}$$

$$P^\circ - \frac{5P^\circ}{M_2} = 2.9$$

$$P^\circ \left(1 - \frac{5}{M_2} \right) = 2.9$$

$$P^\circ \left(\frac{M_2 - 5}{M_2} \right) = 2.9 \quad \text{(ii)}$$

UNIT 8: QUANTITATIVE CHEMICAL EQUILIBRIUM

8

8.1. Key unit competency

To be able to write expressions and calculate the values of equilibrium constant, interpret the values of K_c in relation to the yield of the products in reversible reactions.

8.2. Prerequisite knowledge and skills

Students will learn better quantitative chemical equilibrium if they have understanding on: The factors that affect chemical equilibrium; reversible reactions; Chatelier's principle; effects of changing temperature, pressure, concentration and pressure on a system in equilibrium; endothermic and exothermic reactions (covered in senior four)

8.3. Cross-cutting issues to be addressed

Environment and Sustainability

Chemical equilibrium deals with reversible reactions which are mainly processes of production in industries. An example is like ammonia gas production which sometimes pollute environment. Ammonia is a common naturally occurring substance. It is also manufactured by man. At normal environmental conditions, pure ammonia is a colourless, pungent-smelling, caustic (corrosive) gas. The main local problem of ammonia released into air is the unpleasant odour, which is detectable even at low concentrations. At particularly high concentrations it can also harm vegetation. The harm caused by ammonia in water bodies is more serious, because it is very toxic to aquatic organisms. Low concentrations of ammonia in soil are natural and actually essential for plant nutrition. Over-fertilization can however lead to excessive concentrations which result in leaching to water bodies. On a wider scale, ammonia plays a role in the transportation and enhanced deposition of acidic pollutants - resulting in acidification of ground and water bodies, which can harm plant and animal life. Not only ammonia but there others like production of sulphuric acid. The teacher must emphasize on the problems that can be caused by those substances and how to prevent and handle them. Therefore measures should always be taken and even during production.

8.4. Guidance on the introductory activity:

Introductory activity

Quantitative chemical equilibrium is not new for learners of senior. In senior four, they have studied the factors that affect chemical equilibrium. That is why the facilitator helps them with questions to recall and introduce the new lesson.

Therefore, the introduction of this unit to students of senior six would be simple. The introductory activity can attract interest of students as it is built on the materials that are around everywhere.

Here is a guide of how this activity can be performed by students guided by the teacher.

- Put your students in groups of 3-4(or even 5 depending on the size of your class)
- Provide them with books or worksheets with the introductory activity, unit 8 from student's book S6.
- Give them time between 15 and 20 minutes to read, analyze, interpret and discuss about the activity. Here they have to observe and analyse the objects in the pictures and answer the questions asked about them. Let them use books or search from internet if possible, in order to discover what they don't discover directly.
- Call one or two groups to present their findings. You may note some key points at this stage.
- Ask other members (randomly) to give their input. Don't worry if some of them fail to reach the exact results. They get to understand as the unit progresses.

Address your views about their presentations. But it is not necessary to conclude. Just motivate them to create curiosity in them

Answers to introductory activity:

1. a) The two chemical reactions are different A cannot complete, it reaches equilibrium, the second can occur and complete. For the first it is shown by \rightleftharpoons while in the second it is shown by \rightarrow

b) A is reversible reaction and B is irreversible reaction

2. a) The equilibrium will shift from left to right, we know that increasing temperature, go hand in hand with endothermic reaction and the reverse reaction is the one which is favored.

b) It does not affect the equilibrium; it can only reduce the time to reach equilibrium.

c) It will shift equilibrium from left to right to reduce the change in oxygen

d) It will shift equilibrium from right to left to reduce the increase in concentration of SO_3

If a system at equilibrium is disturbed by a change in temperature, pressure, or the concentration of one of the components, the system will shift its equilibrium position so as to counteract the effect of the disturbance".

3. The forward reaction will be favored which means that equilibrium shift from left to right.

4. a) The equilibrium will shift from right to left to favor the endothermic reaction as we know that increase in temperature favors the endothermic reaction.

b) The production of ammonia will reduce because the reaction which is favored is from right to left.

5. The equilibrium shift from left to right to favor the production of ammonia with fewer number of moles.

8.5. List of lessons

	Lesson title	Learning objectives	Number of periods
1	Definition and characteristics of equilibrium constant, K_c .	- Explain how the temperature affects the magnitude of equilibrium constant K_c	2
2	Deriving equilibrium constant	- Derive equilibrium constant K_c	2
3	Mass action law and equilibrium constant expression	- Appreciate the values of K_c in relation to the completion of different reactions	1
4	Definition of equilibrium constant in terms of partial pressures ' K_p '	Derive the equilibrium constant K_p	2
5	Derivation of the relationship between K_c and K_p	- Derive the relationship between K_c and K_p - Write expression for K_c and K_p	1
6	Calculation on K_c and K_p	- Performing calculations involving equilibrium constants in terms of concentration K_c and partial pressure K_p	2
7	Comparison between reaction quotient q_c and equilibrium constant K_c .	Compare the K_c value with Q_c value and predict if a reaction is at equilibrium or not	2
8	Summative assessment		2

Lesson 1: Definition and characteristics of equilibrium constant, K_c

a. Prerequisites/Revision/Introduction:

Students will learn better characteristics of equilibrium constant if they have knowledge on reversible reactions and on factors that affect chemical equilibrium (covered in senior four)

b. Teaching resources

You can use worksheets/books, projectors /chalkboard, etc.

C. Learning activities

- Before teaching this topic, be aware that students know something about factors that affect the chemical equilibrium.
- As a facilitator, you are expected to guide learners to learn by doing **activity 8.1**, as described below.
- Give the activity to students. This activity has to be done in pairs and it takes at most 15 min.
- Choose randomly three representatives of all groups to present their findings.
- Allow some other students to comment about the findings presented by their colleagues.
- Give your feedback highlighting characteristics of equilibrium constant.
- Through different small verbal questions, help the students to make the conclusion themselves.
- To check their understanding, give them the **Checking Up 8.1** in the Student's Book as an individual homework. The feedback will be given in the next session after the correction.
- You may refer to the proposed answers of the **Activity 8.1** and the **Checking up 8.1**

Answers to activity 8.1 in students' book

- a) Decrease in pressure shifts equilibrium from left to right (the forward reaction), which favors the reaction that produces the products with increase in volume.
 - b) There will be no change on equilibrium because there is same number of moles on both sides.
 - c) The equilibrium will shift from left to right to favor the production of CO and H₂.
2. The equilibrium will shift from left to right to favor the forward reaction which is endothermic reaction.

Answers to checking up 8.1 in Student's Book

- 1 a) Decrease in pressure favors the reverse reaction that produces SO₂ and O₂
 - b) The time to reach equilibrium will multiply by two, because the equilibrium does not change equilibrium but it affects the time to reach at it.
2. High pressure favors the production of ammonia because ammonia is on the side with few moles. And it is known that the increase in pressure favors reaction that reduces the volume.

Lesson 2: Deriving equilibrium constant K_c

a. Prerequisites/Revision/Introduction:

Students will learn better the methods of deriving the equilibrium constant if he has got the knowledge of factors that affect chemical equilibrium that has been covered in senior four.

b. Teaching resources

You can use worksheets/books, projectors /chalkboard, etc.

c. Learning activities

- As a facilitator, you are expected to guide learners to learn by doing **activity 8.2**, as described below.
- Give the activity to students. This activity has to be done in group of 5 and it takes at most 20 min.
- Choose randomly some students in different groups to present their findings.
- Allow some other students to comment about the findings presented by their colleagues.
- Give your feedback in making clear where is the missing relevant information especially in the description of the process of deriving equilibrium constant.
- Through different small verbal questions, help the students to make the conclusion themselves.
- To check their understanding, give them the **Checking Up 8.2** in the Student's Book as an individual work. The feedback will be given in the next session after the correction.
- You may refer to the proposed answers of the **Activity 8.2** and the **Checking up 8.2**

Answers to activity 8.2 in students' book

$$1. \text{ a) } K_c = \frac{[Fe^{2+}]^2 [Sn^{4+}]}{[Fe^{3+}]^2 [Sn^{2+}]}$$

$$\text{ b) } K_c = \frac{[Fe^{3+}]}{[Fe^{2+}][Ag^+]}$$

$$\text{ c) } K_c = \frac{[Cr^{2+}]^2 [Fe^{2+}]}{[Cr^{3+}]^2}$$

$$2. K_c = \frac{[C]^2}{[A][B]} = \frac{(0.50)^2}{(0.25) \times (0.4)} = \frac{0.25}{0.1} = 0.025$$

3.	2D	+	E	\rightleftharpoons	F
Before	1mol		0.75		0
Equilibrium	0.70		0.60		0.15

$$K_c = \frac{[F]}{[D]^2[E]} = \frac{(0.15)}{(0.70)^2(0.60)} = \frac{0.15}{0.49 \times 0.60} = \frac{0.15}{0.294} = 0.51 \text{ mol}^{-2}\text{dm}^6$$

Answers to checking up 8.2 in Student's Book

Answer:

1. a) $K_c = \frac{[I_2^-]}{[H_2][I^-]}$, unit is $\text{mol}^{-1}\text{dm}^3$

b) $K_c = \frac{[NH_3]^2}{[N_2][H_2]^3}$, unit = $\frac{1}{\text{mol}^2 \text{dm}^{-6}} = \text{mol}^{-2} \text{dm}^6$

1. 2.a) $K_c = \frac{[SO_3]^2}{[O_2][SO_2]^2}$, unit = $\text{mol}^{-1} \text{dm}^3$

b) The concentration of $SO_3 = \frac{1.00}{2} = 0.5 \text{ mol dm}^{-3}$

The concentration of $SO_2 = \frac{0.4}{2} = 0.2 \text{ mol dm}^{-3}$

The concentration of $O_2 = \frac{0.03}{2} = 0.015 \text{ mol dm}^{-3}$

$$K_c = \frac{(0.5)^2}{[0.2][0.015]^2} = 416.7 \text{ mol}^{-1} \text{dm}^3$$

Lesson 3: Mass action law and equilibrium constant expression

a) Prerequisites/Revision/Introduction:

Refer to lesson 1

b) Teaching resources

You can use worksheets/books, projectors /chalkboard, etc.

c) Learning activities

- As a facilitator, you are expected to guide learners to learn by doing activity 8.3, as described below.
- Give the activity to students. This activity has to be done in group of 4 and it takes at most 20 min.
- Choose randomly some students in different groups to present their findings.
- Allow some other students to comment about the findings presented by their colleagues.
- Give your feedback making clear it is needed.
- Through different small verbal questions, help the students to make the conclusion themselves.
- To check their understanding, give them the Checking Up 8.3 in the Student's Book as a homework that must be submitted individually. The feedback will be given in the next session after the correction.
- You may refer to the proposed answers of the Activity 8.3 and the Checking up 8.3

Answers to activity 8.3 in students' book

1. Law of Mass Action or Equilibrium law states that "The ratio of a equilibrium concentrations of products and reactants each raised to the power of their coefficients in the balanced stoichiometric equations is a constant, K_c , at a constant temperature.

2. According to law of mass action: the total mass of A and B involved in the collision must be equal to the total mass of new formed compounds

$$\text{Rate of forward reaction} \propto [A]^a[B]^b = K_f [A]^a[B]^b$$

$$\text{Rate of backward reaction} \propto [C]^c[D]^d = K_b [C]^c[D]^d$$

The concentration is expressed in unit moles per unit volume.

Answers to checking up 8.3 in Student's Book

$$\text{a) } K_c = \frac{[R]^2}{[Q][P]^2}$$

$$\text{b) } K_c = \frac{[Fe^{3+}]}{[Fe^{2+}][Ag^+]}$$

$$\text{c) } K_c = \frac{[H_2][CO_2]}{[CO][H_2O]}$$

$$\text{d) } K_c = \frac{[SO_3]^2}{[O_2][SO_2]^2}$$

$$\text{e) } K_c = \frac{[Cr^{2+}]^2[Fe^{2+}]}{[Cr^{3+}]^2}$$

Lesson 4: Definition of equilibrium constant in terms of partial pressures “K_p”

a. Prerequisites/Revision/Introduction:

Learners will learn better the equilibrium constant in terms of partial pressures “K_p” if they have knowledge on ideal gas law and partial pressures (covered in senior five)

b. Teaching resources

You can use worksheets/books, projectors /chalkboard, etc.

c. Learning activities

-
- As a facilitator, you are expected to guide learners to learn by doing **activity 8.4**, as described below.
- Give the activity to students. This activity has to be done in group of 4 and it takes at most 15 min.
- Choose randomly some students in different groups to present their findings.
- Allow some other students to comment about the findings presented by their colleagues.
- To check their understanding, give them the **Checking Up 8.4** in the Student’s Book as an individual homework. The feedback will be given in the next session after the correction.
- You may refer to the proposed answers of the **Activity 8.4** and the **Checking up 8.4**

Answers to activity 8.4 in students’ book

1. $PV = nRT$

2. $P =$ pressure, $V =$ volume, $n =$ number of moles, $R =$ gas constant, $T =$ temperature.

Partial pressure is the hypothetical pressure of the gas if it, alone, occupied the entire volume of the original mixture at the same temperature. The total pressure of an ideal gas mixture is the sum of the partial pressures of the gases in the mixture.

Answers to checking up 8.4 in Student’s Book

1)

$$\text{a) } K_p = \frac{P_{SO_3}}{[P_{SO_2}][P_{O_2}]^{\frac{1}{2}}} = \frac{1 \text{ atm}}{[0.05][0.025]^{\frac{1}{2}}} = \frac{1}{0.05 \times 0.158} = \frac{1}{0.0079} = 126.58 \text{ atm}^{-1/2}$$

$$\text{b) } K_p = \frac{(P_{SO_3})^2}{(P_{O_2})(P_{SO_2})^2} = \frac{(1 \text{ atm})^2}{[0.025][0.05]^2} = \frac{1}{0.0000625} = 16,000 \text{ atm}^{-1}$$

$$2. K_p = \frac{P_{H_2} \cdot P_{CO_2}}{P_{H_2O} \cdot P_{CO}}$$

b) No effect on hydrogen gas. The pressure does not affect the equilibrium for that reaction because on both sides of chemical equation there is same number of moles. Right hand side, there are two moles which is the same for the left hand side.

$$3. K_p = \frac{(P_{SO_3})^2}{(P_{O_2})(P_{SO_2})^2}$$

$$P_{SO_3} = 1.04 - p_{SO_2} - p_{O_2} = 1.04 - 0.025 - 0.64 = 0.15 \text{ atm}$$

$$K_p = \frac{(P_{SO_3})^2}{(P_{O_2})(P_{SO_2})^2} = \frac{(0.15)^2}{(0.64)(0.25)^2} = 0.5625 \text{ atm}^{-1}$$

Lesson 5: Derivation of the relationship between Kc and Kp

a. Prerequisites/Revision/Introduction:

Students will learn better the method of relating Kc to Kp when they have the knowledge on Kc and Kp that have been learnt in previous lessons.

b. Teaching resources

You can use worksheets/books, projectors /chalkboard, etc.

c. Learning activities

- As a facilitator, you are expected to guide learners to learn by doing **activity 8.5**, as described below.
- Give the activity to students. This activity has to be done in pairs and it takes 10 to 15 min.
- Choose randomly some students in different groups to present their findings.
- Allow some other students to comment about the findings presented by their colleagues.
- Give your feedback making clear where it is necessary.
- Through different small verbal questions, help the students to make the conclusion themselves.
- To check their understanding, give them the **Checking Up 8.5** in the Student's Book as a work in pairs. The feedback will be given in the next session after the correction.
- You may refer to the proposed answers of the **Activity 8.5** and the **Checking up 8.5**

Answers to activity 8.5 in students' book

1. The equilibrium constant, K_c , is the ratio of the equilibrium concentrations of products over the equilibrium concentrations of reactants each raised to the power of their stoichiometric coefficients while when the pressure is proportional to the concentration for gases in a closed system, the equilibrium constant can be written in terms of the pressures of the different components rather than their molecular concentrations and K_p expression is used.

Answers to checking up 8.5 in Student's Book

1. a) $K_p = K_c(RT)^{\Delta n}$, $\Delta n = 2 - (2+1) = -1$

$$K_p = K_c (RT)^{-1}$$

$$K_p = \frac{K_c}{RT}$$

b) $K_p = \frac{K_c}{RT}$, $R = 0.082 \text{ atm mol}^{-1} \text{ K}^{-1}$, $T = 4500^\circ\text{C} + 273 = 4773 \text{ K}$, $K_c = 0.2 \text{ atm}^{-1}$

$$K_p = \frac{0.2}{0.082 \times 4773} = \frac{0.2}{391.386} = 5.11 \times 10^{-4} \text{ atm}^{-2} \text{ mol}$$

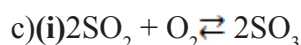

(ii) Vanadium pentoxide (V_2O_5)

(iii) $K_p = \frac{P_{\text{SO}_2}^2}{P_{\text{SO}_2}^2 \times P_{\text{O}_2}}$



Initial amount 2000 1000 2x

At equilibrium 2000-2x 1000-x

Amount of SO_2 remains = $2000 - 2x = 1333$

$$- 2x = 1333 - 2000$$

$$- 2x = -667$$

$$x = 333.5$$

Amount of SO_2 at equilibrium = 1333 cm^3

Amount of O_2 at equilibrium = $1000 \text{ cm}^3 - 333.5 \text{ cm}^3 = 666.5 \text{ cm}^3$

Amount of SO_3 at equilibrium = $2 \times 333.5 = 667 \text{ cm}^3$

Total volume = $1333 + 666.5 + 667 = 2666.5 \text{ cm}^3$

Partial pressure = molar fraction x total pressure

$$P_{SO_2} = \frac{1333 \times 10}{2666.5} = 5 \text{ atm}$$

$$P_{O_2} = \frac{667 \times 10}{2666.5} = 2.5 \text{ atm}$$

$$P_{SO_3} = \frac{667 \times 10}{2666.5} = 2.5 \text{ atm}$$

$$(v) K_p K_p = \frac{2.5^2}{5^2 \times 2.5} = 0.1 \text{ atm}^{-1}$$

Lesson 6: Calculations on K_c and K_p

a. Prerequisites/Revision/Introduction:

Learners will learn better how to calculate the K_c and K_p if he mastered well the formula of K_c and K_p and their unit and that have been covered in the previous lessons.

b. Teaching resources

You can use worksheets/books, projectors /chalkboard, etc.

c. Learning activities

- As a facilitator, you are expected to guide learners to learn by doing **activity 8.6**, as described below.
- Give the activity to students. This activity has to be done individually and it takes at most 15 min.
- Choose randomly some students in different groups to present their findings.
- Allow some other students to comment about the findings presented by their colleagues.
- Give your feedback making clear where it is needed
- Through different small verbal questions, help the students to make the conclusion themselves.
- To check their understanding, give them the **Checking Up 8.6** in the Student's Book as an individual work. The feedback will be given in the next session after the correction.
- You may refer to the proposed answers of the **Activity 8.6** and the **Checking up 8.6**

Answers to activity 8.6 in students' book

$$1. K_c = \frac{[C]^3}{[A]^2[B]}$$

$$K_p = \frac{P_C^3}{P_A^2 \cdot P_B}$$



a) 1 mole of NH_3 was produced by 46 kJ/mol

2 moles of NH_3 were produced by 46×2 kJ

34 g of NH_3 were produced by 92 kJ

1.02×10^9 g NH_3 produces $= \frac{92 \times 1.02 \times 10^9}{34} = 2.76 \times 10^9 \text{ kJ mol}^{-1}$ each day.



At equilibrium 0.6 2.0 ??

Total moles on the left hand side = $0.6 + 2.0 = 2.6$

4 moles of N_2 and H_2 produced 2 moles of NH_3

2.6 moles of N_2 and H_2 produced $\frac{2 \times 2.6}{4} = 1.3$ moles

$$[\text{N}_2] = \frac{0.6 \text{ mol}}{2 \text{ dm}^3} = 0.3 \text{ M}$$

$$[\text{H}_2] = \frac{2.0 \text{ mol}}{2 \text{ dm}^3} = 1 \text{ M}$$

$$[\text{NH}_3] = \frac{1.3 \text{ mol}}{2 \text{ dm}^3} = 0.65 \text{ M}$$

$$(ii) \quad K_c = \frac{[\text{NH}_3]^2}{[\text{N}_2][\text{H}_2]^3} = \frac{0.65^2}{0.3 \times 1^3} = 1.4 \text{ mol}^{-2} \text{ dm}^{-6}$$

Answers to checking up 8.6 in Student's Book

Answer:

$$1. \quad 1.K_c = \frac{0.56}{(0.44)^2} = 2.89$$

$$2. \quad 2.K_c = \frac{0.11 \times (0.27)^2}{(0.03)^2} = 8.91$$



1

1

0

0

0.333

0.333

0.667

0.667

$$K_c = \frac{(0.667) \times (0.667)}{(0.333 \times 0.333)} = 4.012$$

Lesson 7: Comparison between reaction quotient q_c and equilibrium constant k_c

a. Prerequisites/Revision/Introduction:

Students will learn better the comparison between q_c and K_c , if they have knowledge of constant equilibrium and reaction quotient (covered in previous lesson and in senior five)

b. Teaching resources

You can use worksheets/books, projectors /chalkboard, etc.

c. Learning activities

- As a facilitator, you are expected to guide learners to learn by doing **activity 8.7**, as described below.
- Give the activity to students. This activity has to be done in group of 4 and it takes at most 15 min.
- Choose randomly some students in different groups to present their findings.
- Allow some other students to comment about the findings presented by their colleagues.
- Give your feedback making clear where it is necessary
- Through different small verbal questions, help the students to make the conclusion themselves.
- To check their understanding, give them the **Checking Up 8.7** in the Student's Book as an individual work. The feedback will be given in the next session after the correction.
- You may refer to the proposed answers of the **Activity 8.7** and the **Checking up 8.7**

Answers to activity 8.7 in students' book

Refer to students' textbook

Answers to checking up 8.7 in Student's Book

1. Refer to students' textbook

2.

$$\text{a) } K_c = \frac{[H_2O]^2 [O_2]}{[H_2O_2]^2}$$

$$\text{b) } K_c = \frac{\uparrow^x}{\downarrow^{0+x_1}}$$

$$\text{c) } K_c = \frac{[H_2O_2]^2}{[H_2O]^2 [O_2]}$$

$$\text{d) } K_c = \frac{[SO_2]^2}{[O_2]^3}$$

$$\text{e) } K_c = [Mg^{2+}][Cl^-]^2$$

2. 3. $Q_p = 16 \text{ atm}$ and $Q_p > K_p$, so the reaction will proceed from right to left, to produce more SO_3

8.6. Summary of the unit

In most of the chemical reactions, the reactants are not completely converted into products. The reaction proceeds to a certain extent and reaches a state at which the concentrations of both reactants and products remain constant with time.

- The equilibrium constant, K_c , is the ratio of the equilibrium concentrations of products over the equilibrium concentrations of reactants each raised to the power of their stoichiometric coefficients.
- For a given chemical equation of a reaction: $a A + b B \rightleftharpoons c C + d D$

$$\text{The equilibrium constant is } K = \frac{[C]^c [D]^d}{[A]^a [B]^b}$$

$$\text{The reaction quotient is } Q = \frac{[C]^c [D]^d}{[A]^a [B]^b}$$

The data derived from experiments, show that, over time, the **quotient** Q tends to approach a constant K for a given reaction in a closed system. Such a state is called **equilibrium**.

The constant K depends on temperature and the nature of the reactants and products. Thus, K is called the equilibrium constant.

- **Law of Mass Action** states that “The rate of a chemical reaction is directly

proportional to the product of the molar concentrations of the reactants at a constant temperature at any given time”.

- Consider the reaction, $\text{H}_2(\text{g}) + \text{I}_2(\text{g}) \rightleftharpoons 2\text{HI}(\text{g})$, where gaseous compounds are involved in the reaction, the equilibrium constant can be written as; $K_p = \frac{(p_{\text{HI}})^2}{p_{\text{H}_2} \times p_{\text{I}_2}}$

Where p_{HI} , p_{H_2} and p_{I_2} are the partial pressures of the different compounds. If no other gases are present.

❖ Relationship between K_c and K_p

$$K_p = \frac{[\text{C}]^c [\text{D}]^d (\text{RT})^{c+d}}{[\text{A}]^a [\text{B}]^b (\text{RT})^{a+b}} = K_c (\text{RT})^{(c+d)-(a+b)}$$

$$= \frac{[\text{C}]^c [\text{D}]^d (\text{RT})^{c+d}}{[\text{A}]^a [\text{B}]^b (\text{RT})^{a+b}} = K_c (\text{RT})^{(c+d)-(a+b)}$$

$$K_p = K_c (\text{RT})^{\Delta n}$$

Where R (ideal gas constant) = 0.0821 L.atm/K. mol⁻¹; T = temperature in Kelvin

Δn = moles of gaseous products - moles of gaseous reactants

- For a reaction of known K_c value, the direction of the net reaction can be predicted by calculating the reaction quotient, Q_c . Consider the reaction: $p\text{A} + q\text{B} \rightleftharpoons r\text{C} + s\text{D}$;

$$Q_c = \frac{[\text{C}]^r [\text{D}]^s}{[\text{A}]^p [\text{B}]^q}$$

- If $Q_c = K_c$:

The reaction is at equilibrium and the concentrations will not change since the rates of forward and backward reactions are equal.

- If $Q_c < K_c$;

The ratio of products over the reactants is too small and the reaction is not at equilibrium; the reaction will move toward the equilibrium by forming more products.

- If $Q_c > K_c$: The ratio of products over the reactants is too large and the reaction is not at equilibrium; the reaction will move toward the equilibrium by forming more reactants.

8.7. Additional information

Some definitions

Heterogeneous system is the one in which the reactants and the products are of the same phase.

Effect of catalyst on the position of equilibrium

A catalyst lowers the energy of the transition state i.e: the activation energy of forward is lowered. This is the same for the reverse reaction.

As a result, a catalyst increases the rate at which equilibrium is achieved, but it does not change the composition of the equilibrium mixture. The value of the equilibrium constant for a reaction is not affected by the presence of catalyst. Hence a catalyst does not affect the position of equilibrium. The rate at which a reaction approaches equilibrium is an important practical consideration.

8.8. End of unit assessment

Answer to end unit questions

$$1.a) K_c = \frac{[N_2] \times [H_2O]^2}{[NO]^2 \times [H_2]^2}$$

b)

	[NO](M)	[H ₂](M)	[N ₂](M)	[H ₂ O](M)
Initial	0.10	0.050	0.00	0.10
Change	-0.038	-0.038	+0.019	+0.038
Equilibrium	0.062	0.012	0.019	0.138

$$[H_2] = 0.012, [N_2] = 0.019M, [H_2O] = 0.138 M$$

$$K_c = \frac{(0.019) \times (0.138)^2}{(0.062)^2 \times (0.012)^2} = 653.681 \text{ mol}^{-1}\text{L}$$

c) Relationship between K_c and K_p

$$K_p = K_c (RT)^{\Delta n_g}$$

$$d) K_p = (653.681 \text{ mol}^{-1}\text{L}) (0.0821 \text{ atm K}^{-1} \text{ mol}^{-1} \times 298\text{K})^{(3-4)} = 26.728 \text{L atm}^{-1}$$

2 a) A dynamic equilibrium is a chemical equilibrium between a forward reaction and the reverse reaction where the rates of reactions are equal in closed system.

$$\text{b. (i) } K_p = \frac{(P_{\text{NH}_3})^2}{P_{\text{N}_2}(P_{\text{H}_2})^3}$$

$$\text{ii) the units of } K_p \rightarrow \frac{\text{atm}^2}{\text{atm} \times \text{atm}^3} = \text{atm}^{-2}$$

c.i) Increasing the pressure favours the forward reaction which produces fewer molecules of gas.

ii) Increasing the temperature favours reverse reaction which is endothermic reaction.

d) The catalyst used in the Haber process is iron.

e. The catalysts increase equally the rates of both forward and backward reactions in equilibrium. So they enable equilibrium to be achieved much more rapidly but they do not alter the concentrations of reacting substances at equilibrium.

$$3.\text{a) } K_c = \frac{[\text{NO}_2]^2}{[\text{N}_2\text{O}_4]}$$

b. Increase in pressure favours side with less number of moles therefore if the pressure is doubled, the backwards reaction will be favoured. NO_2 will decompose into N_2O_4 .

$$\text{.a)i) } K_p = \frac{P_{\text{H}_2}^4}{P_{\text{H}_2\text{O}}^4}$$

$$\text{ii) } K_p = \frac{P_{\text{COCl}_2}}{P_{\text{CO}} \times P_{\text{Cl}_2}}$$

b) Reaction I: Increase in pressure will shift to the right where there is a few number of moles.

Reaction II: Increase in pressure has no effect on the equilibrium position since the number of moles of gases on the left hand side is equal to the number of moles on the right hand side.

$$5.\text{a) } K_c = \frac{[\text{NH}_3]^2}{[\text{N}_2][\text{H}_2]^3}$$

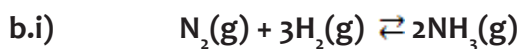

Initial conc.	0.20	0.20	0
At eqm	0.20-x	0.20-3x	2x

$$2x = 0.060$$

$$x = 0.030 \text{ mol}$$

At equilibrium $[N_2]$: $0.20 - 0.03 = 0.17 \text{ mol}$

At equilibrium $[H_2]$: $0.20 - 3 \times 0.03 = 0.11 \text{ mol}$

$$\text{ii) } K_c = \frac{(0.06)^2}{(0.17)(0.11)^3} = 15.9$$

$$K_c = \frac{(\text{mol dm}^{-3})^2}{(\text{mol dm}^{-3})(\text{mol dm}^{-3})^3} = \text{mol}^2 \text{dm}^{-6}$$

c) An increase in pressure favours the forward reaction, thus the yield of ammonia (NH_3) increases. Because high pressure favours the direction where the number of moles decreases (Le Chatelier's principle)

d) A low temperature would give a higher yield but the rate would be too slow, hence not economical. A higher temperature of 5000°C increases the rate. A high pressure increases the yield but if it is higher than 200 atm, it becomes very expensive because of the higher cost of repairing broken parts.

e) Manufacture of fertilizers

Manufacture of nitric acid.

6.a) There is increase in moles of gas (volume) in the forward reaction. Increase in pressure favours the backward reaction or shifts equilibrium position to the left where there are a few moles of gas.

$$\text{b) } K_c = \frac{[H_2]^3 [CO_2]}{[CH_4][H_2O]} ; \text{units of } K_c \text{ are } \text{mol}^2 \text{dm}^{-6}$$

8.9 Additional activities

Remedial activities

1.0 mole of sulphur dioxide was introduced into a 1 dm^3 vessel. The vessel was heated to 1000 K until equilibrium was attained. At equilibrium, 0.35 mole of sulphur trioxide was present:

Write;

i) Equation for decomposition of sulphur trioxide

ii) an expression for the equilibrium constant K_c

Calculate the K_c value

0.2 mole of sulphur dioxide, 0.1 mole of oxygen and 0.7 mole of sulphur trioxide were introduced into the vessel in a) at 1000 K.

i) Calculate the new K_c value for the reaction

ii) Using your answers in b) and c)i), state how the position of equilibrium has been affected.

Consider the reaction between sulphur dioxide and oxygen to produce sulphur trioxide at 700°C:



Write the expression for the equilibrium constant, K_c , for the above reaction and give its units

iii) Nitrogen is added?

iv) The volume of reaction vessel is increased?

The equilibrium mixture of the above reaction at 700°C contains 0.4 mole of sulphur dioxide, 0.03 mole of oxygen and 1.00 mole of sulphur trioxide in a 2.0 dm³ container. Calculate the value of K_c .

Answers

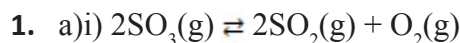

$$\text{ii) } K_c = \frac{[\text{SO}_2]^2[\text{O}_2]}{[\text{SO}_3]^2}$$

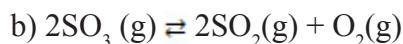

$$0.35 \qquad 0.65 \qquad 0.325$$

$$K_c = \frac{(0.65)^2(0.325)}{(0.35)^2} = 1.05 \text{ mol dm}^{-3}$$



$$[\text{O}_2] = 0.325 + 0.10 = 0.425$$

$$[\text{SO}_3] = 0.35 + 0.70 = 1.05$$

$$K_c = \frac{(0.85)^2(0.425)}{(1.05)^2} = 0.279 \text{ mol dm}^{-3}$$

ii) The value of K_c in (b) is greater than in (c) i). This means that the position of the equilibrium has shifted to the left.

2. a) $K_c = \frac{[SO_3]^2}{[SO_2]^2[O_2]}$; mol⁻¹ dm³

b) i) The concentration of sulphur trioxide in the equilibrium mixture would decrease because the reaction is exothermic in the forward direction.

ii) The concentration of sulphur trioxide in the equilibrium mixture would increase as the equilibrium shifts to the right.

iii) Nitrogen is an inert gas and it reduces the partial pressure of the gases in the equilibrium mixture. Reduction in pressure is opposed by the equilibrium shifting in a direction, which leads to an increase in volume, which in this case, is the backward direction. Consequently, the concentration of sulphur trioxide would decrease as the equilibrium shift to the left.

iv) The concentration of sulphur trioxide would decrease as the equilibrium shifts to the left.

c) [] signifies concentration in mol dm⁻³

Therefore, concentration of SO₃ = $\frac{1.00}{2} = 0.5 \text{ mol dm}^{-3}$

Concentration of SO₂ = $\frac{0.4}{2} = 0.2 \text{ mol dm}^{-3}$

Concentration of oxygen = $\frac{0.03}{2} = 0.015 \text{ mol dm}^{-3}$

$K_c = \frac{(0.5)^2}{(0.2)^2(0.0150)} = 416.7 \text{ mol}^{-1} \text{ dm}^3$

Consolidation activities

1. The exothermic reaction between nitrogen and hydrogen takes place according to the equation:



a) Write the expression for the equilibrium constant, K_c for the forward reaction.

a) At 500°C, the equilibrium concentration of hydrogen is 0.25 mol dm⁻³ and that of nitrogen is 0.27 mol dm⁻³. Calculate the equilibrium concentration of ammonia at the same temperature, given that the equilibrium constant $K_c = 6.0 \times 10^{-2} \text{ mol}^{-2} \text{ dm}^6$ at 500°C.

- b) What would happen to the ammonia in the equilibrium mixture if:
- helium was added at 500°C?
 - the temperature was increased
2. a) The degree of dissociation of 3.4 moles of hydrogen iodide at 468°C was found to be 20 percent. Calculate:
- The number of moles of hydrogen iodide, hydrogen and iodine formed at equilibrium
 - The equilibrium constant for the dissociation reaction
- b) A mixture containing 28 moles of hydrogen and 22 moles of iodine was heated in a sealed tube at 463°C until equilibrium was reached, when 36 moles of hydrogen iodide was obtained. Calculate the degree of dissociation of hydrogen iodide at 463°C.

Answers

$$\text{a) } K_c = \frac{[\text{NH}_3]^2}{[\text{N}_2][\text{H}_2]^3}$$

$$\text{b) } [\text{N}_2] = 0.27; [\text{H}_2] = 0.25; [\text{NH}_3]^2 = K_c [\text{N}_2][\text{H}_2]^3$$

$$[\text{NH}_3] = \sqrt{K_c [\text{N}_2][\text{H}_2]^3} = \sqrt{6.0 \times 10^{-2} \times 0.27 \times (0.25)^3} = 1.59 \times 10^{-2} \text{ mol dm}^{-3}$$

c) i) The concentration of ammonia would decrease.

ii) the concentration of ammonia would decrease since the forward reaction is exothermic.

a) Hydrogen iodide dissociates according to the following equation:



Initially, there were 3.4 moles of HI. The degree of dissociation, α is 20% (0.20)

At equilibrium;

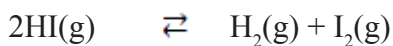

$$3.4(1-\alpha) \qquad \frac{3.4}{2} \alpha \qquad \frac{3.4}{2} \alpha$$

i) The number of moles of HI at equilibrium = $3.4(1-\alpha) = 3.4(1-0.20) = 2.72$

$$\text{Number of moles of H}_2 \text{ at equilibrium} = \frac{3.4}{2} \alpha = \frac{3.4}{2} (0.20) = 0.34$$

The equilibrium constant for the dissociation for the dissociation reaction can be obtained by making an assumption that the volume of the reaction vessel is V litres. For n moles of HI dissociating, initial molar concentrations is $\frac{n}{v}$

Therefore, equilibrium molar concentrations are

$$[\text{HI}] = \frac{2n(1-\alpha)}{V} \quad ; \quad [\text{H}_2] = \frac{n\alpha}{V} \quad [\text{I}_2] = \frac{n\alpha}{V}$$

ii) The equilibrium constant, $K_c = \frac{[\text{H}_2][\text{I}_2]}{[\text{HI}]^2}$

$$\text{Therefore, } K_c = \frac{\frac{n\alpha}{V} \frac{n\alpha}{V}}{\left(\frac{2n(1-\alpha)}{V}\right)^2} = \frac{\alpha^2}{4(1-\alpha)^2} = \frac{(0.20)^2}{4(1-0.20)^2} = 0.01562 \text{ or}$$

$$1.562 \times 10^{-2}$$

b) The equation for the formation of hydrogen iodide is: $\text{H}_2(\text{g}) + \text{I}_2(\text{g}) \rightleftharpoons 2\text{HI}(\text{g})$

Let the initial number of moles be as follows:

Moles of $\text{H}_2 = a$; Moles of $\text{I}_2 = b$; Moles of HI = 0

Let the number of moles of at equilibrium be:

Moles of $\text{H}_2 = (a-x)$; moles of HI = $2x$; moles of $\text{I}_2 = (b-x)$

In this case, $2x = 36$ and $x = 18$

$a = 28$ and $b = 22$

$a-x = 10$ and $b-x = 4$

Therefore, equilibrium constant,

$$K_c = \frac{(2x)^2}{(a-x)(b-x)} = \frac{(36)^2}{10 \times 4} = 32.4$$

Equation for the dissociation of hydrogen iodide is:

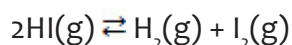

For n moles of HI dissociating, the initial molar concentrations is $\frac{n}{V}$
 (Assuming the volume of the reaction vessel is V litres)

Therefore, the equilibrium molar concentrations are

$$[\text{HI}] = \frac{2n(1-\alpha)}{V} \quad ; \quad [\text{H}_2] = \frac{n\alpha}{V} \quad [\text{I}_2] = \frac{n\alpha}{V}$$

Where α is the degree of dissociation. The equilibrium constant for the dissociation is

$$\frac{\frac{n\alpha}{V} \frac{n\alpha}{V}}{\left(\frac{2n(1-\alpha)}{V}\right)^2} = \frac{\alpha^2}{4(1-\alpha)^2}$$

But this equilibrium constant for dissociation of HI is equal to $\frac{1}{K_c}$ for the formation of HI above: the K_c in(i) is 32.4

Therefore, $\frac{\alpha^2}{4(1-\alpha)^2} = \frac{1}{K_c} = \frac{1}{32.4} \dots(ii)$

By taking square root of each side in(ii)

$$\frac{\alpha}{4(1-\alpha)} = \frac{1}{5.69} \Rightarrow 5.69\alpha = 2 - 2\alpha$$

Therefore, the degree of dissociation at 4.63° c = 0.26 (or 26%)

1. a) At 122°C, silver carbonate decomposes to silver oxide and carbon dioxide according to the equation:



- i) The equilibrium constant, K_p , for the reaction at 122°C is 9.5×10^{-3} atmospheres. Calculate the partial pressure of carbon dioxide. State any assumptions made.
- ii) At 122°C and 1 atmosphere pressure, air contains 1% of carbon dioxide. Calculate the partial pressure of carbon dioxide in the air.

- b) State whether there would be any change in the mass of silver carbonate at equilibrium when the percentage of carbon dioxide was increased to 4%. Give reasons for your answer.

2. Hydrogen Iodide decomposes when heated, according to the equation:

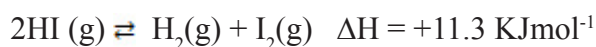

- a) Write an expression for the equilibrium constant, K_c , for the reaction
- b) 1.54g of hydrogen iodide was heated in a 600 cm³ bulb at 530°C. When equilibrium was attained, the bulb was rapidly cooled to room temperature and broken under potassium iodide solution. The iodine formed from the decomposition required 67.0cm³ of 0.1M sodium thiosulphate solution for complete reaction. Calculate:
- The number of moles of hydrogen iodide in 1.54g (H=1, I = 127)
 - The number of moles of iodine formed when hydrogen iodide was decomposed.
 - The value of K_c at 530°
- c) State the effect on the value of K_c if
- the temperature was raised from 530° to 800°C
 - The volume of the bulb was increased to 1200cm³

Answers

1. a) i) Assuming that the decomposition occurs in a closed system, the equilibrium constant, K_p , for decomposition is equal to the partial pressure of carbon dioxide. The concentration of solid silver carbonate and silver oxide remain constant during the reaction, and therefore do not take part in the equilibrium as they are in solid state. The carbon dioxide is assumed to behave ideally. The pressure of the carbon dioxide is therefore constant at any temperature.

$$p\text{CO}_2 = K_p = 9.5 \times 10^{-3} \text{ atmospheres}$$

$$\text{ii) Partial pressure of CO}_2 = \frac{1}{100} \times 1 = 0.01 \text{ atmospheres}$$

b) Since the equilibrium position for this reaction is attained because the system is closed, there will be no change in the mass of silver carbonate. The system does not gain or lose matter to the surroundings, and the amount of carbon dioxide at that temperature will be constant, and so the quantity of silver carbonate and silver oxide will not change.

$$2. \text{ a) } K_c = \frac{[\text{H}_2][\text{I}_2]}{[\text{HI}]^2} =$$

b) i) The number of moles of hydrogen iodide in 1.54g

$$= \frac{1.54}{128} = 0.012$$

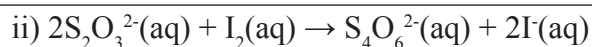

$$\text{Number of moles of } \text{S}_2\text{O}_3^{2-}, \text{ which reacted} = \frac{67.0 \times 0.1}{1000} = \mathbf{0.0067}$$

Therefore, number of moles of I_2 which reacted = $0.0067 \times 1/2 = 0.00335$

Number of moles of I_2 formed when HI was decomposed = 0.00335 moles

iii) Total number of moles of HI before reaction = 0.012. Since 2 moles of HI forms 1 mole of hydrogen or 1 mole of iodine, then moles of HI reacted = $0.00335 \times 2 = 0.0067$. The moles of HI which remained unreacted at equilibrium = $(0.012 - 0.0067) = 0.0053$. At equilibrium, moles of hydrogen formed is equal to moles of iodine formed = 0.00335.

$$K_c = \frac{(0.00335)^2}{(0.0053)^2} = \mathbf{0.40}$$

a) i) The value of K_c would increase, since the forward reaction is endothermic.

ii) The value of K_c would not change.

UNIT 9: pH OF ACIDIC AND ALKALINE SOLUTIONS

9

9.1. Key unit competence

To be able to prepare solutions, measure their pH, and calculate the pH of acidic and alkaline solutions. Explain the concept of buffer solution, hydrolysis of salts and discuss its applications in manufacturing industry and biological processes.

1. 9.2. Prerequisite knowledge and skills

Learners can understand pH of acidic and alkaline solutions better when they have knowledge from laboratory and safety apparatus, solutes, solvents and solution, acids, bases and pH, salts and their properties, the mole concept and concentration of solutions. These are some of the units covered progressively from senior two to senior five.

9.3. Cross-cutting issues to be addressed

Environment and sustainability

Acids, bases and salts are the most common chemicals in the laboratory. They are almost used every day for all classes from senior one to senior six in various experiments. Others occur naturally in the environment mostly in soil and water. Acids and bases may either be strong or weak and they may be found either dilute or concentrated in the laboratory. Salts may be acid, alkaline or neutral. They are prepared by several methods but mostly from acids and bases discussed above.

Acidic solutions can burn the skin with just one drop due to a high affinity for water, can damage lungs when inhaled, and corrode metals in different metallic products reducing their quality. Acidic rains destroy off massive numbers of vegetation, kill soil living organisms and dissolve rocks and minerals.

Most salts are used as fertilizers which increase crop production but when applied excessively, they cause ground water contamination, burn crops, increase air pollution (release greenhouse gases), deplete minerals from the soil, acidify the soil and may be washed to water bodies. This leads to rapid growth of algae which utilize oxygen that would be used by fish causing them to suffocate.

Inclusive education

This unit involves a lot of research and calculations. To be able to understand it, there must be discussions, experiments and sharing of information among learners. You can

organize your class and use different strategies to help all learners understand concepts very well. Some of the strategies to be used are provided in the introductory part of this book.

- Gender:

During group activities try to form heterogeneous groups i.e. boys and girls or when learners start to present their findings, encourage both boys and girls to present one after the other.

- Financial education:

As this unit deals with many acids, bases and salts in modern life, you will draw learners' attention on the economic impact of the making common products using that knowledge.

- Peace and values:

During group activities, you will encourage learners to work together, help each other where seems to be difficulty, and to respect other's opinions, critiquing but not criticizing their ideas.

9.4. Guidance on the introductory activity:

pH is not a new word or abbreviation to learners. They are even familiar with some of the key words used in this unit such as an acid, a base, a salt, ionization etc. Therefore, the introduction of this unit to learners is simple and will attract learners' interests as it builds on the products they use or see every single day

Here is a guide of how this activity can be conducted by the learners with guidance from the teacher:

- Put your learners in groups of 4 or 6 depending on the size of your class.
- Provide them with senior six chemistry students' books and guide them on the page where the unit and the introductory activity is.
- Ask them to look at the pictures of some useful products made of acids, bases and salts.
- Give them five minutes time to read, analyze and discuss about the activity. Here they have to observe and analyse the pictures and answer the questions thereafter.
- Invite one representative from each group to present their findings. You may note some key points on the board
- Ask learners at random to give their input considering the bright and weak learners in your class. Don't worry if some of them fail to reach the exact results. Give them time to observe, make research on the internet to come to exact answers.
- Give them your views about their presentations citing some exact answers suggested below. It is not necessary to conclude here, just motivate them to continue researching on the products in the pictures using the given questions of the introductory activity.

9.5. List of lessons

#	Lesson title	Learning objective(s)	Periods
1	Degree of ionization in relation to strength of acids and bases	<ul style="list-style-type: none"> Differentiate between strong acid and strong base, weak acid and weak base Define and perform calculations involving degree of ionization (α) 	2
2	Explanation of acid and base dissociation constants (K_a and K_b)	<ul style="list-style-type: none"> Define the term K_a and K_b Write expressions for K_a and K_b of weak acids and weak bases respectively. 	1
3	Relationship between K_a and K_b	<ul style="list-style-type: none"> Write an expression to show the relationship between K_a and K_b 	1
4	Use K_a or pK_a and K_b or pK_b to explain the strength of the acids and bases.	<ul style="list-style-type: none"> Interpret the values of K_a and K_b, pK_a and pK_b in relation to the strength of acids and bases. Compare the strength of acids and bases of same concentration, using the values of K_a and K_b 	1
5	Explanation of ionic product of water (K_w)	<ul style="list-style-type: none"> Define the term pH, K_w and pK_w 	1

6	Definition and calculations of pH and pOH of acidic and alkaline solutions.	<ul style="list-style-type: none"> • Perform calculations involving pH, pOH, K_a, pK_a, K_b, pK_b, K_w and pK_w • Relate the values of pH and pOH • Interpret results, draw valid conclusions and report about preparation of solutions with different pH 	4
7	Salt hydrolysis	<ul style="list-style-type: none"> • Write equations for salt hydrolysis reactions and expressions for salt hydrolysis constant, K_h • Calculate the pH and the hydrolysis constant, K_h of aqueous solutions of salts. • Perform experiments to show that hydrolysis of some salts results in neutral, acidic and alkaline solutions. 	4
8	Buffer solutions	<ul style="list-style-type: none"> • Define the term buffer solution. • Derive Henderson-Hasselbalch relation and use it to calculate the pH of buffer solutions. 	5

9	Preparation of buffer solutions of different pH	<ul style="list-style-type: none"> • Prepare different solutions and appropriately use a pH meter to measure their pH 	2
10	Explanation of the working of buffer solutions.	<ul style="list-style-type: none"> • Explain how buffers solution control pH. • Explain buffer capacity in relation to buffer range. • Describe the applications of buffer solutions in domains such as biological processes, agriculture, natural systems and industries 	5
11	End unit assessment		2

Lesson 1: Degree of ionization in relation to strength of acids and bases

(a) Prerequisites.

Learners will understand better this lesson if they have knowledge about definition of an acid and a base from different theories.

Differences between a strong acid and a weak acid, differences between a strong base and weak base, partial and complete ionization of weak and strong electrolytes.

(b) Teaching resources

Use worksheets or books, computer, projectors and/or chalkboard, appropriate chemicals such as sodium hydroxide, aqueous ammonia, sulphuric acid and ethanoic acid from the school laboratory.

(c) Learning activities

Guide learners on clearly defining a weak acid and a weak base as these definitions are not new to them. Let them discuss about examples of weak acids and bases and write equations to show their ionization in water. With the help of some examples, do exercises on calculations of the degree of ionization. Use α -values to predict the strength of the acids and bases. You will discuss with them as they note down the summary. End

the lesson with a simple discussion about the dangers of acids and bases to human and the environment. Finally, give them the checking up activity as homework.

Suggested answers to introductory activity

- 1.(a) Sulphuric acid, H_2SO_4 (b) Sodium hydroxide, NaOH
(c) Ascorbic acid, $\text{C}_6\text{H}_8\text{O}_6$ (d) Sodium chloride, NaCl
(e) Sodium hydrogen carbonate, NaHCO_3 (f) Calcium carbonate, CaCO_3
- 2.(a) An acid (b) A base (c) An acid (d) A salt (e) A salt (f) A salt
- 3.(a) pH is less than 7 (b) pH is greater than 7
(c) pH is less than 7 (d) pH is at 7
(e) pH is greater than 7 (f) pH is greater than 7

Answers to activity 9.1

(a)(i) **An acid** is a proton donor Or **An acid** is an electron pair acceptor

Or **An acid** is a substance which ionizes/dissociates in aqueous solution to produce hydrogen ions as the only positively charged ions in solution.

(ii) **A base** is a proton acceptor Or **A base** is an electron pair donor

Or **A base** is a substance which ionizes/dissociates in aqueous solution to produce hydroxyl/hydroxide ions as the only negatively charged ions in solution.

(b) Examples of acids

- Sulphuric acid
- Hydrochloric acid
- Carbonic acid
- Ethanoic acid
- Methanoic acid
- Citric acid
- Ascorbic acid
- Sulphurous acid etc.

Examples of bases

- Sodium hydroxide
- Potassium hydroxide
- Magnesium hydroxide
- Calcium hydroxide
- Lead (II) hydroxide
- Copper (II) hydroxide
- Calcium oxide
- Sodium oxide
- Potassium oxide

Note: Bases can either be oxides or alkalis

(c) **Strong acid** is the one that ionizes/dissociates completely/fully in aqueous solutions to produce hydrogen/hydroxonium ions in solution.

Strong base is the one that ionizes/dissociates partially in aqueous solutions to produce hydroxyl/hydroxide ions in solution.

(d) **Weak acid** ionizes/dissociates partially in aqueous solutions to produce few hydrogen/hydroxonium ions while **weak bases** also ionize/dissociate partially in

Aqueous solutions to produce few hydroxyl/hydroxide ions in solution.

(e) **Weak acid**

- Carbonic acid
- Ethanoic acid
- Phosphoric acid
- Citric acid
- Ascorbic acid etc.

Weak bases

- Aqueous ammonia
- Phenylamine
- Hydroxylamine
- Methylamine
- Ethylamine
- Propylamine etc.

(f) Weak acid e.g. ethanoic acid, CH_3COOH ionizes/dissociates in water as follows:

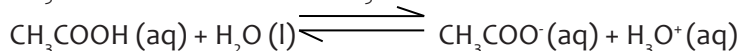
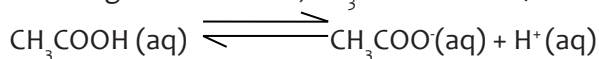

Weak bases e.g. aqueous ammonia, NH_3 ionizes/dissociates in water as follows:

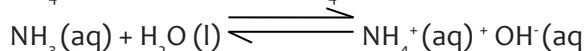
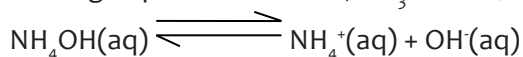

Answers to checking up 9.1

$$1. \quad \alpha_a = \frac{[\text{H}^+]}{[\text{Acid}]} = \frac{0.0042}{0.1} = 0.042 \times 100 = \underline{4.2\%}$$

$$2. \quad \alpha_a = \frac{[\text{H}^+]}{[\text{Acid}]} = \frac{0.0037}{0.35} = 0.01 \times 100 = \underline{1\%}$$

Lesson 2: Explanation of acid and base dissociation constants (K_a and K_b)

(a) Prerequisites

Learners will understand better this lesson when they have knowledge and skills on ionization of weak electrolytes, writing equations of reactions which are reversible, applying the law of mass action (equilibrium law)

(b) Teaching resources

The teacher can use a computer and a projector, chalkboard and a scientific calculator since this lesson involves some calculations.

(c) Learning activities

You will group learners into pairs (a boy and a girl where applicable), provide them with student's books and guide them on the page where the activity is located. Ask them to discuss, present their findings. You will iron out some issues and they take a summary of the facts.

Answers to activity 9.2

1. (a) Acid dissociation constant is the equilibrium constant for the ionization/dissociation of a weak acid, denoted by K_a .

(b) Base dissociation constant is the equilibrium constant for the ionization/dissociation of a weak base, denoted by K_b .

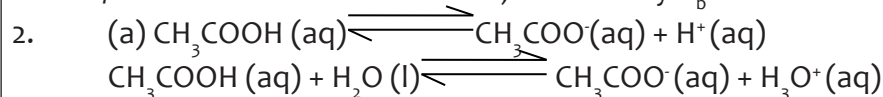

(b) $K_a = \frac{[\text{CH}_3\text{COO}^-][\text{H}^+]}{[\text{CH}_3\text{COOH}]}$ or $K_a = \frac{[\text{CH}_3\text{COO}^-][\text{H}_3\text{O}^+]}{[\text{CH}_3\text{COOH}]}$

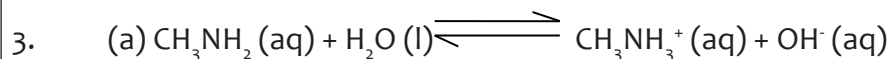

(b) $K_b = \frac{[\text{CH}_3\text{NH}_3^+][\text{OH}^-]}{[\text{CH}_3\text{NH}_2]}$

Answers to checking up 9.2

$$1. \alpha = \sqrt{\frac{K_a}{C_a}} = \sqrt{\frac{1.3 \times 10^{-5}}{0.04}} = 0.09$$

$$\alpha = 0.09 \times 100 = 9\%$$

$$2. \alpha = \sqrt{\frac{K_a}{C_a}} = \sqrt{\frac{4.39 \times 10^{-5}}{0.01}} = 0.002$$

$$\alpha = 0.002 \times 100 = 0.2\%$$



(b) $K_b = \frac{[\text{CH}_3\text{NH}_3^+][\text{OH}^-]}{[\text{CH}_3\text{NH}_2]}$

(c) Since the base is partially dissociated, $[CH_3NH_3^+] = [OH^-] = 0.04M$

$$K_b = \frac{[OH^-]^2}{[CH_3NH_2]} = \left(\frac{0.04^2}{1}\right)$$

$$K_b = 1.6 \times 10^{-3} \text{ mol dm}^{-3}$$

Lesson 3: Relationship between K_a and K_b

(a) Prerequisites

Learners will understand better this relationship using knowledge and skills partial ionization of weak electrolytes, law of mass action (equilibrium law) and expressions for equilibrium constant, K_a and K_b

(b) Teaching resources

Use textbooks, worksheets, flip charts and chalkboard.

(c) Learning activities

Refer to lesson to lesson for the methodological steps to be used.

Answers to activity 9.3

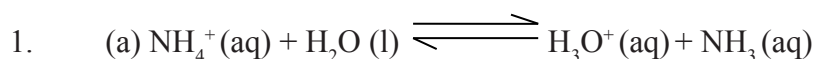

(b) $K_a = \frac{[NH_3][H_3O^+]}{[NH_4^+]}$

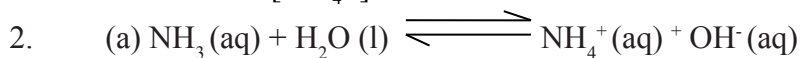

(b) $K_b = \frac{[NH_4^+][OH^-]}{[NH_3]}$

Answers to checking up 9.3

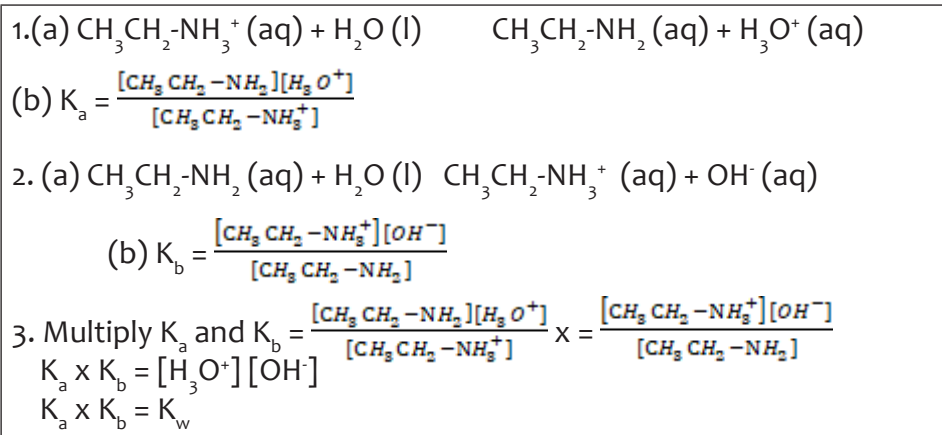

Lesson 4: Use K_a or pK_a and K_b or pK_b to explain the strength of the acids and bases.

(a) Prerequisites

Students will learn these concepts better if they have knowledge on degree of ionization, factors that influence the strength of acids and bases, ionization constants of acids and bases, calculations of K_a and K_b .

(b) Teaching resources

Use textbooks, worksheets, flip charts, chalkboard and a calculator.

(c) Learning activities

- The activity reminds learners on expressions of base and acid dissociation constants and introduces them to a related scale measuring acidity or alkalinity of a solution.
- Brainstorm with your learner on the prior knowledge of ionization of weak electrolytes and expressions of base or acid ionization constants.
- Your discussions should include term pH is derived from “p” which is a mathematical symbol of negative logarithm, and “H,” the chemical symbol for Hydrogen, then pK_a and pK_b , and how to calculate pH, pK_a and pK_b .
- Let learners perform the activity in **pairs** using their prior knowledge and write their ideas on worksheet.
- Have sample group present their work to the class.
- Check learners’ responses to views being given and continue involving other learners in the discussion with concepts from students’ work and

student's book.

- Comment on students' responses and give them the summary of expected feedback based on their findings.

Answers to activity 9.4

1. (a) $\text{pK}_a = -\log_{10} K_a$
(b)(i) Strongest acid is HCOOH and the weakest acid is $\text{C}_6\text{H}_5\text{OH}$.
(ii) The higher the K_a value, the stronger the acid. This is because of increase in the degree of ionization.



At equilibrium. $C(1 - \alpha) \quad C\alpha \quad C\alpha$

$$K_a = \left(\frac{C\alpha \cdot C\alpha}{C(1 - \alpha)} \right) = \left(\frac{C\alpha^2}{(1 - \alpha)} \right)$$

$$K_a = C\alpha^2$$

$$\alpha = \sqrt{\frac{K_a}{C}}$$

Where α = Degree of ionization, K_a = Acid dissociation constant and C = Concentration of the acidic solution

Answers to checking up 9.4

1. (a) For 1M HF, $K_a = 6.3 \times 10^{-4} \text{ mol dm}^{-3}$

$$\text{pK}_a = -\log(6.3 \times 10^{-4})$$

$$\text{pK}_a = 4 - \log(6.3)$$

$$\underline{\text{pK}_a = 3.2}$$

1M HCN, $K_a = 6.2 \times 10^{-10} \text{ mol dm}^{-3}$

$$\text{pK}_a = -\log(6.2 \times 10^{-10})$$

$$\text{pK}_a = 10 - \log(6.2)$$

$$\underline{\text{pK}_a = 9.2}$$

1M $\text{H}_2\text{C}_2\text{O}_4$, $K_a = 5.0 \times 10^{-2} \text{ mol dm}^{-3}$

$$\text{pK}_a = -\log(5.0 \times 10^{-2})$$

$$\text{pK}_a = 2 - \log(5.0)$$

$$\underline{\text{pK}_a = 1.3}$$

1M CH_3COOH , $K_a = 1.25 \times 10^{-3} \text{ mol dm}^{-3}$

$$\text{pK}_a = -\log(1.25 \times 10^{-3})$$

$$\text{pK}_a = 3 - \log(1.25)$$

$$\underline{\text{pK}_a = 2.9}$$

(b) 1M $\text{H}_2\text{C}_2\text{O}_4$ is the strongest acid. It has a large K_a value but a smaller pK_a value.

This means that the acid is highly ionized/dissociated in solution.
 1M HCN is the weakest acid. It has a smaller K_a value but a larger pK_a value.
 This means that HCN is weakly/less ionized/dissociated in solution.
 (c) $1M H_2C_2O_4 > 1M CH_3COOH > 1M HF > 1M HCN$ or $H_2C_2O_4 > CH_3COOH > HF > HCN$

$$2. \quad pK_a + pK_b = 14$$

$$pK_b = 14 - pK_a = 14 - 7.29$$

$$\underline{pK_b = 6.71}$$

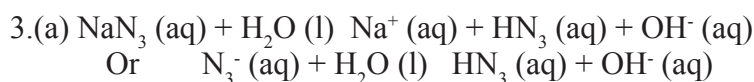

$$(b) K_a \times K_b = K_w$$

$$K_b = \left(\frac{K_w}{K_a} \right) = \left(\frac{10^{-14}}{1.9 \times 10^{-5}} \right)$$

$$\underline{K_b = 5.26 \times 10^{-10} \text{ mol dm}^{-3}}$$

Lesson 5: Explanation of ionic product of water (K_w)

(a) Prerequisites

Learners will understand ionic product of water if they have prior information on ionization of water, equilibrium law, and mathematical expression of pH, nature of water

(b) Teaching resources

Use worksheets, flip charts, chalkboard, beaker, water, litmus paper, pH scale and a calculator.

(c) Learning activities

Before introducing the lesson with content, let learners attempt activity 9.5 from the student's book.

As a facilitator, you are expected to guide learners through the following steps:

- Organize your class by putting students into group of 3 or 4 depending on the size of the class.
- Give each group a beaker of water, litmus papers of different colours and a pH meter.

- Instruct a learner in each group to add a litmus papers separately and tell the colour change.
- Then instruct another learner from each group to insert a pH meter and read the pH of water and tell other learners.
- Provide learners with student's books and guide them on the page where they can find the activity and discuss the questions.
- Give them enough time to think and discuss about the possible answers.
- Check learners responses and ideas, continue the discussions with a brief brainstorming of the content using students' book.
- Comment on learners' responses and give them the summary of expected feedback based on their findings.

Answers to activity 9.5

1.(a)(i) Water has a pH of 7 because it is a neutral molecule. The concentration of hydrogen ions in water is $1.0 \times 10^{-7} \text{ mol dm}^{-3}$.

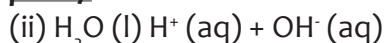
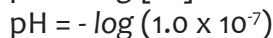
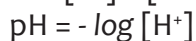
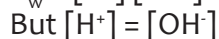

(iii) Ionic product of water is an equilibrium constant, K_w that shows the product of the molar concentrations of hydrogen ions and hydroxide ions produced by water on ionization.

Or an equilibrium constant K_w which shows the product of the molar concentrations of hydroxonium ions and hydroxyl ions in water.



Answers to checking up 9.5

- (a) $K_w = [\text{H}^+][\text{OH}^-]$ or $K_w = [\text{H}_3\text{O}^+][\text{OH}^-]$
(b) Units are $\text{Mol}^2 \text{dm}^{-6}$
- (a) From $K_w = [\text{H}^+][\text{OH}^-]$
 $[\text{H}^+]^2 = 1.471 \times 10^{-14} \text{ mol}^2 \text{dm}^{-6}$
 $[\text{H}^+] = 1.213 \times 10^{-7} \text{ mol dm}^{-3}$
 $\text{pH} = -\log [\text{H}^+]$
 $\text{pH} = -\log (1.213 \times 10^{-7})$
pH = 6.92
(b) Water is still neutral because the pH is still in the range of neutral conditions 6.5-7.5. This means that there is still equal number of hydrogen ions and hydroxide ions.
- $\text{p}K_w = -\log K_w$
 $\text{p}K_w = -\log (1.471 \times 10^{-14})$
pK_w = 13.83

Lesson 6: Definition and calculations of pH and pOH of acidic and alkaline solutions

(a) Prerequisites

Learners will understand calculations involving pH and pOH of acidic and alkaline solutions if they have prior information on ionization of acids and alkalis, degree of ionization, acid and base dissociation constant and mathematical expression of pH and pOH, knowledge about logarithm rules.

(b) Teaching resources

Use worksheets, chalkboard and calculators.

(c) Learning activities

Refer to lesson 5 for methodological steps on how to conduct the lesson and the activities.

Answers to activity 9.6

- (a) $\text{pH} = -\log_{10}[\text{H}^+]$ or $\text{pH} = -\log_{10}[\text{H}_3\text{O}^+]$
(b) $3.5 = -\log_{10}[\text{H}^+]$
 $[\text{H}^+] = 3.16 \times 10^{-4} \text{ mol dm}^{-3}$
- $\text{HNO}_3(\text{aq}) \rightleftharpoons \text{H}^+(\text{aq}) + \text{NO}_3^-(\text{aq})$

$[\text{HNO}_3] = [\text{H}^+]$ since the mole ratio is 1:1

$[\text{H}^+] = 0.025 \text{ mol dm}^{-3}$

$\text{pH} = -\log_{10}[\text{H}^+] = -\log_{10}(2.5 \times 10^{-2})$

$\text{pH} = 1.6$



Since mole ratio is 1:2, $[\text{H}^+] = 2 \times 0.02 = 4.0 \times 10^{-2} \text{ mol dm}^{-3}$

$\text{pH} = -\log_{10}[\text{H}^+] = -\log_{10}(4.0 \times 10^{-2})$

$\text{pH} = 1.4$



Equation	$\text{NH}_3(\text{aq})$	\rightleftharpoons	$\text{NH}_4^+(\text{aq})$	$\text{OH}^-(\text{aq})$
Initial concentration	C		0	0
Concentration on ionization	C α		C α	C α
Concentration at equilibrium	C - C α		C α	C α

From the equation, $[\text{NH}_3(\text{aq})] = [\text{OH}^-]$, since mole ratio is 1:1

$[\text{OH}^-] = C\alpha = 0.01 \times 0.04 \text{ mol dm}^{-3}$

$[\text{OH}^-] = 4.0 \times 10^{-4} \text{ mol dm}^{-3}$

$\text{pOH} = -\log_{10}[\text{OH}^-] = -\log_{10}(4.0 \times 10^{-4})$

$\text{pOH} = 3.4$

$\text{pH} = \text{p}K_w - \text{pOH} = 14 - 3.4$

$\text{pH} = 10.6$

5. C

6. B

7. A

Answers to checking up 9.6

1. $\text{pH} = -\log_{10}[\text{H}^+]$

$4 = -\log_{10}[\text{H}^+]$

$[\text{H}^+] = \log^{-1}(-4) = 1.0 \times 10^{-4} \text{ mol dm}^{-3}$

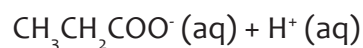
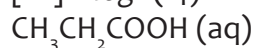

$K_a = \left(\frac{[\text{CH}_3\text{CH}_2\text{COO}^-][\text{H}^+]}{[\text{CH}_3\text{CH}_2\text{COOH}]} \right)$

$$K_a = \left(\frac{[H^+]^2}{c_a} \right) = \frac{(1.0 \times 10^{-4})^2}{0.05}$$

$$K_a = 2.0 \times 10^{-7} \text{ mol dm}^{-3}$$



$$[\text{HCOOH}] = [\text{H}^+] = 0.001 \text{ or } 1.0 \times 10^{-3} \text{ mol dm}^{-3}$$

$$[\text{H}^+] = C\alpha = (1.0 \times 10^{-3}) \times 0.01$$

$$[\text{H}^+] = 1.0 \times 10^{-5} \text{ mol dm}^{-3}$$

$$\text{Or } K_a = \left(\frac{[\text{H}^+]^2}{c_a} \right)$$

$$[\text{H}^+] = \sqrt{(1.0 \times 10^{-7}) \times 0.001}$$

$$[\text{H}^+] = 1.0 \times 10^{-5} \text{ mol dm}^{-3}$$

$$\text{pH} = -\log_{10}[\text{H}^+] = -\log_{10}(1.0 \times 10^{-5})$$

$$\underline{\underline{\text{pH} = 5}}$$

3. From $\text{pOH} = 14 - \text{pH} = 14 - 6.9$

$$\text{pOH} = 7.1$$

$$\text{Also } \text{pOH} = -\log_{10}[\text{OH}^-]$$

$$7.1 = -\log_{10}[\text{OH}^-]$$

$$[\text{OH}^-] = \log^{-1}(-7.1)$$

$$[\text{OH}^-] = 7.9 \times 10^{-8} \text{ mol dm}^{-3}$$



Mole ratio $\text{NaOH} : \text{OH}^-$ is 1:1, the molarity of $\text{NaOH} = \underline{\underline{7.9 \times 10^{-8} \text{ mol dm}^{-3}}}$



1 mole of KOH produces 1 mole of OH^-

$$[\text{KOH}] = [\text{OH}^-] = 2.2 \times 10^{-5} \text{ mol dm}^{-3}$$

$$\text{pOH} = -\log_{10}[\text{OH}^-] = -\log_{10}(2.2 \times 10^{-5})$$

$$\underline{\underline{\text{pOH} = 4.7}}$$



1 mole of NaOH produced 1 mole of OH^-

$$[\text{NaOH}] = [\text{OH}^-] = 0.4 \text{ or } 4.0 \times 10^{-1} \text{ mol dm}^{-3}$$

$$\text{pOH} = -\log_{10}[\text{OH}^-] = -\log_{10}(4.0 \times 10^{-1})$$

$$\text{pOH} = 0.39$$

$$\text{pH} = \text{pK}_w - \text{pOH} = 14 - 0.39$$

$$\underline{\underline{\text{pH} = 13.61}}$$

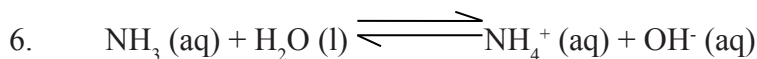

$$K_b = \frac{[\text{NH}_4^+][\text{OH}^-]}{[\text{NH}_3]}$$

$$K_b = \frac{[\text{OH}^-]^2}{c_b}$$

$$[\text{OH}^-] = \sqrt{(1.85 \times 10^{-5}) \times 0.005}$$

$$[\text{OH}^-] = 3.04 \times 10^{-4} \text{ mol dm}^{-3}$$

$$\text{pOH} = -\log_{10} [\text{OH}^-] = -\log_{10} (3.04 \times 10^{-4})$$

$$\text{pOH} = 4 - \log (3.04)$$

$$\text{pOH} = 3.5$$

$$\text{pH} = \text{p}K_w - \text{pOH} = 14 - 3.5$$

$$\text{pH} = 10.5$$

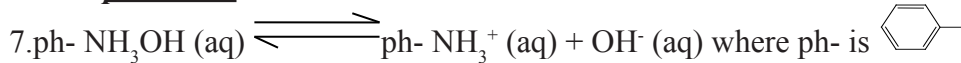

$$[\text{OH}^-] = C\alpha = 0.01 \times 0.08$$

$$[\text{OH}^-] = 0.0008 \text{ mol dm}^{-3}$$

$$K_b = \left(\frac{[\text{ph-NH}_3^+][\text{OH}^-]}{[\text{ph-NH}_2\text{OH}]} \right)$$

$$K_b = \frac{[\text{OH}^-]^2}{c_b} = \frac{(0.0008)^2}{0.01}$$

$$K_b = 6.4 \times 10^{-5} \text{ mol dm}^{-3}$$

Alternatively, you can find K_b from the expression: $K_b = C\alpha^2$

$$K_b = 0.01 \times (0.08)^2 = 6.4 \times 10^{-5} \text{ mol dm}^{-3}$$

$$\text{Then, pOH} = -\log_{10} [\text{OH}^-] = -\log_{10} (8.0 \times 10^{-4})$$

$$\text{pOH} = 4 - \log 8$$

$$\text{pOH} = 3.1$$

$$\text{pH} = \text{p}K_w - \text{pOH} = 14 - 3.1$$

$$\text{pH} = 10.9$$

8. From $\text{pOH} = \text{p}K_w - \text{pH} = 14 - 10.6$

$$\text{pOH} = 3.4$$

$$\text{pOH} = -\log_{10} [\text{OH}^-]$$

$$[\text{OH}^-] = \frac{1}{10^{3.4}} = 3.98 \times 10^{-4} \text{ mol dm}^{-3}$$

$$K_b = \frac{[\text{OH}^-]^2}{c_b} = \frac{(3.98 \times 10^{-4})^2}{0.01}$$

$$K_b = 1.58 \times 10^{-5} \text{ mol dm}^{-3}$$

$$\text{From, } \alpha = \sqrt{\frac{K_b}{C_b}} = \sqrt{\frac{1.58 \times 10^{-5}}{0.01}} = 0.04$$

$$\alpha = 0.04 \times 100 = 4\%$$

9. $\text{pH} = -\log_{10}[\text{H}^+]$
 $4.35 = -\log_{10}[\text{H}^+]$
 $[\text{H}^+] = 4.47 \times 10^{-5} \text{ mol dm}^{-3}$

From the equation, $\text{H}_2\text{SO}_4(\text{aq}) \longrightarrow 2 \text{H}^+(\text{aq}) + \text{SO}_4^{2-}(\text{aq})$
Mole ratio H_2SO_4 : is 1:2

$$\text{Molarity of } \text{H}_2\text{SO}_4 \text{ is } = \frac{1 \times 4.47 \times 10^{-5}}{2}$$

$$\text{Molarity} = 2.235 \times 10^{-5} \text{ mol dm}^{-3}$$

10. $\text{HCl}(\text{aq}) \longrightarrow \text{H}^+(\text{aq}) + \text{Cl}^-(\text{aq})$
 $[\text{HCl}] = [\text{H}^+]$ since mole ratio = 1:1, therefore, $[\text{H}^+] = 0.05$ or $5.0 \times 10^{-2} \text{ mol dm}^{-3}$

$$\text{pH} = -\log_{10}[\text{H}^+] = -\log_{10}(5.0 \times 10^{-2})$$

$$\text{pH} = 1.3$$

Lesson 7: Salt hydrolysis

(a) Prerequisites

Learners will understand better this part of salt hydrolysis if they have prior knowledge on acids and bases, different methods of salt preparation, solubility of salts, pH and pOH of acidic and alkaline solutions, equilibrium constants for reactions which are reversible and expressions of pH and pOH.

(b) Teaching resources

Use a computer and a projector, worksheets and textbooks, flip charts and chalkboard, sodium chloride, ammonium chloride, sodium ethanoate, water, beakers, stirring rod, litmus papers and a pH meter.

(c) Learning activities

Before learners attempt activity 9.7, first give them this simple practical that will drive them to the activity and finally a better understanding of the content.

As a teacher, you are expected to guide learners through the following steps:

- Organize your class by putting students into group of 5 or 6 depending on the size of the class.

- Give each group three beakers, water, three different salts i.e. sodium chloride, sodium ethanoate and ammonium chloride, litmus papers of different colours and a pH meter.
- Instruct a learner in each group to add a little water into a beaker, followed by a small sample of sodium chloride, stir the mixture to form a solution, test the solution with litmus papers and note the colour change.
- Using a different learner, repeat the above procedure with sodium ethanoate and then ammonium chloride. Let them also note their observations.
- Then instruct other different learners from each group to insert a pH meter and read the pH of the resultant solutions and tell other learners to note it down.
- Provide learners with student's books and guide them on the page where they can find the activity and discuss the following questions.
- Give them enough time to think and discuss about the possible answers.
- Check learners responses and ideas, continue the discussions with a brief brainstorming of the content using students' book.
- Comment on learners' responses and give them the summary of expected feedback based on their findings.
- Discuss about the adverse effects of salts in soil and water bodies. End the lesson with checking up activity as homework.

Answers to activity 9.7

1. Refer to students' book

2. **Normal salts.** These are salts formed when all the replaceable hydrogen atoms of an acid are completely replaced by a metal or ammonium group during neutralization with a base.

Examples of normal salts include; sodium chloride (NaCl), potassium carbonate (K_2CO_3), ammonium phosphate $(NH_4)_3PO_4$, etc.

Acid salts. These are salts formed when part of the hydrogen atoms of an acid are replaced by a metal during neutralization with a base. This means that some hydrogen atoms are still in the salt formed.

Examples of acid salts include; sodium hydrogen sulphate ($NaHSO_4$), sodium hydrogen carbonate ($NaHCO_3$), etc.

3.

- **Direct combination of elements** e.g. NaCl from sodium and chlorine, FeCl_3 from iron and chlorine, AlCl_3 from aluminium and chlorine etc.
- **Action of an acid on a metal** e.g. ZnSO_4 from zinc and sulphuric acid, $\text{Cu}(\text{NO}_3)_2$ from copper and nitric acid, MgSO_4 from magnesium and sulphuric acid etc.
- **Action of an acid on an insoluble carbonate** e.g. ZnSO_4 from zinc carbonate and sulphuric acid, CaCl_2 from calcium carbonate and hydrochloric acid, $\text{Pb}(\text{NO}_3)_2$ from lead (II) carbonate and nitric acid.
- **Neutralization of acid and alkali** e.g. NaCl from sodium hydroxide and hydrochloric acid, Na_2SO_4 from sodium hydroxide and sulphuric acid etc.

Or neutralization of an acid by a basic oxide e.g. CuSO_4 from copper (II) oxide and sulphuric acid, ZnSO_4 from zinc oxide and sulphuric acid, $\text{Pb}(\text{NO}_3)_2$ from lead (II) oxide and nitric acid etc.

- **Double decomposition/precipitation** e.g. BaCl_2 from Barium chloride and sulphuric acid, PbCl_2 from lead (II) nitrate and sodium chloride, CaCO_3 from calcium chloride and sodium carbonate etc.

4. Refer to students' book

5. Na_2CO_3 , CH_3COONa , NH_4Cl , NH_4NO_3 , $\text{CH}_3\text{COO}\cdot\text{NH}_4^+$, $(\text{NH}_4)_2\text{CO}_3$ etc. Refer to students' book, for more examples. Note that salts of strong acid and strong base do not undergo hydrolysis.

6. (a)(i) $\text{C}_6\text{H}_5\text{COO}^- (\text{aq}) + \text{H}_2\text{O} (\text{l}) \rightleftharpoons \text{C}_6\text{H}_5\text{COOH} (\text{aq}) + \text{OH}^- (\text{aq})$

$$(ii) K_h = \frac{[\text{C}_6\text{H}_5\text{COOH}][\text{OH}^-]}{[\text{C}_6\text{H}_5\text{COO}^-]}$$

$$(b) \text{From } K_h = \frac{[\text{C}_6\text{H}_5\text{COOH}][\text{OH}^-]}{[\text{C}_6\text{H}_5\text{COO}^-]}$$

$$K_h = \frac{[\text{OH}^-]^2}{[\text{C}_6\text{H}_5\text{COO}^-]}$$

$$[\text{OH}^-] = \sqrt{(1.6 \times 10^{-10}) \times 0.2}$$

$$[\text{OH}^-] = 5.66 \times 10^{-6} \text{ mol dm}^{-3}$$

$$\text{pOH} = -\log_{10} [\text{OH}^-] = -\log_{10} (5.66 \times 10^{-6})$$

$$\text{pOH} = 5.25$$

$$\text{From } \text{pH} = \text{p}K_w - \text{pOH} = 14 - 5.25$$

$$\text{pH} = 8.75$$

Answers to checking up 9.7

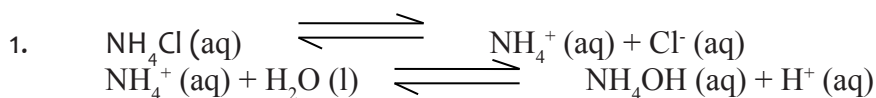

$$K_h = \frac{[\text{NH}_4\text{OH}][\text{H}^+]}{[\text{NH}_4^+]} = \frac{[\text{H}^+]^2}{c_s}$$

$$[\text{H}^+] = \sqrt{K_h \cdot c_s} = \sqrt{(6.34 \times 10^{-8}) \times 0.1}$$

$$[\text{H}^+] = 7.96 \times 10^{-8} \text{ mol dm}^{-3}$$

$$\text{pH} = -\log_{10} [\text{H}^+] = -\log_{10} (7.96 \times 10^{-8})$$

$$\text{pH} = 4.1$$

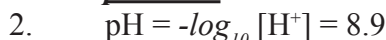

$$K_w = 1.0 \times 10^{-14} \quad \text{p}K_w = 14$$

$$\text{pOH} = 14 - 8.9 = 5.1$$

$$\text{From } \text{pOH} = -\log_{10} [\text{OH}^-]$$

$$[\text{OH}^-] = 10^{-5.1} = 7.94 \times 10^{-6} \text{ mol dm}^{-3}$$



$$K_h = \frac{[\text{CH}_3\text{CH}_2\text{COOH}][\text{OH}^-]}{[\text{CH}_3\text{CH}_2\text{COO}^-]} = \frac{[\text{OH}^-]^2}{c_s}$$

$$K_h = \left(\frac{(7.94 \times 10^{-6})^2}{0.1} \right)$$

$$K_h = 5.3 \times 10^{-10} \text{ mol dm}^{-3}$$

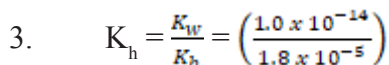

$$K_h = 5.56 \times 10^{-10} \text{ mol dm}^{-3}$$



$$K_h = \frac{[\text{NH}_4\text{OH}][\text{H}^+]}{[\text{NH}_4^+]} = \frac{[\text{H}^+]^2}{c_s}$$

$$[\text{H}^+] = \sqrt{K_h \cdot c_s} = \sqrt{(5.56 \times 10^{-10}) \times 0.01}$$

$$[\text{H}^+] = 2.36 \times 10^{-6} \text{ mol dm}^{-3}$$

$$\text{pH} = -\log_{10} [\text{H}^+] = -\log_{10} (2.36 \times 10^{-6})$$

$$\text{pH} = 6 - \log 2.36$$

$$\text{pH} = 5.6$$

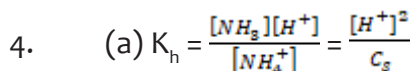

$$[\text{H}^+] = \sqrt{(5.6 \times 10^{-10}) \times 0.1} = 7.483 \times 10^{-6} \text{ mol dm}^{-3}$$

$$\text{pH} = -\log_{10} [\text{H}^+] = -\log_{10} (7.483 \times 10^{-6})$$

$$\text{pH} = 6 - \log (7.483)$$

$$\text{pH} = 5.13$$

$$(b) [\text{H}^+] = C\alpha$$

$$\alpha = \left(\frac{7.483 \times 10^{-6}}{0.1} \right)$$

$$\alpha = 7.483 \times 10^{-5} \times 100$$

$$\alpha = 7.483 \times 10^{-3}\%$$

Lesson 8: Buffer solutions

(a) Prerequisites

Learners will understand better buffer solutions if they have prior knowledge acids and alkalis, chemical equilibrium, pH and pOH of acidic and alkaline solutions,

(b) Teaching resources

Use a computer and a projector, worksheets and textbooks, flip charts and chalkboard, sodium chloride, ammonium chloride, sodium ethanoate, sodium hydroxide and hydrochloric acid, water, beakers, weighing scale, measuring cylinder, stirring rod, and a pH meter.

(c) Learning activities

- First discuss with learners about checking up activity 9.7. Give them facts and let them make corrections if any.
 - Organize your class by putting learners into group of 3 to 5 depending on the size of the class.
 - Let learners discuss the activity using their prior knowledge and write their ideas on worksheets.
 - Have sample groups to present their ideas/findings to the class.
 - Check learners' responses and give them a summary of expected feedback based on their findings. This will lead you to discussion of general content.
 - Involving all learners in the discussion of concepts. Comment on the

students' responses.

- Direct the learners to the checking up 9.8 at the end of the lessons or give it to them as homework.

Answers to activity 9.8

Refer to students' book

Answers to checking up 9.8

1. $\text{pH} = \text{pK}_a + \log\left(\frac{[\text{Salt}]}{[\text{Acid}]}\right)$

$$4 = -\log(6.31 \times 10^{-5}) + \log\left(\frac{[\text{Salt}]}{[0.012]}\right)$$

$$\text{Log}[\text{salt}] = 2.121$$

$$[\text{Salt}] = 7.56 \times 10^{-3} \text{ mol/litre}$$

Thus, mass of sodium benzene carboxylate = concentration x molar mass

$$= 7.56 \times 10^{-3} \times 114$$

$$= \mathbf{1.088 \text{ g/litre}}$$

2. (a) Molar mass of $\text{C}_6\text{H}_5\text{COONa} = 144\text{g/mole}$

$$[\text{Salt}] = \left(\frac{7.2}{144}\right) = 0.05 \text{ mol dm}^{-3}$$

$$\text{pH} = \text{pK}_a + \log\left(\frac{[\text{Salt}]}{[\text{Acid}]}\right)$$

$$= -\log(6.25 \times 10^{-5}) + \log\left(\frac{0.05}{0.02}\right)$$

$$\mathbf{\text{pH} = 4.6}$$

(b) On addition of 0.01M NaOH, the added hydroxide ions react with benzoic acid. This decreases [Acid] but increases the [Salt]

$$\text{New}[\text{Acid}] = 0.02 - 0.01 \text{ mol dm}^{-3}$$

$$\text{New}[\text{Salt}] = 0.05 + 0.01 = 0.06 \text{ mol dm}^{-3}$$

$$\text{New pH} = -\log(6.25 \times 10^{-5}) + \log\left(\frac{0.06}{0.01}\right)$$

$$\text{pH} = 5 - \log 6.25 + \log 6$$

$$\mathbf{\text{pH} = 4.98}$$

$$\text{pH change} = 4.98 - 4.6 = \mathbf{0.38 \text{ units}}$$

3. Concentration of HCl = $\left(\frac{0.1 \times 10}{1000}\right) = 0.001 \text{ mol dm}^{-3}$

$$\text{Concentration of } \text{NH}_4\text{OH} = \left(\frac{0.05 \times 100}{1000}\right) = 0.005 \text{ mol dm}^{-3}$$

0.001 moles of HCl reacted with 0.001 moles of NH_4OH to form 0.001 moles of NH_4Cl

$$\text{Moles of unreacted } \text{NH}_4\text{OH} = (0.005 - 0.001) = 0.004 \text{ mol dm}^{-3}$$

$$pOH = -\log(1.8 \times 10^{-5}) + \log\left(\frac{0.001}{0.004}\right)$$

$$pOH = 4.14$$

$$\text{From } pH = pK_w - pOH = 14 - 4.14$$

$$**pH = 9.86**$$

4. (a) Concentration of $NH_4OH = \left(\frac{80 \times 0.4}{1000}\right) = 0.032 \text{ mol dm}^{-3}$

$$\text{Concentration of HCl} = \left(\frac{100 \times 0.1}{1000}\right) = 0.01 \text{ mol dm}^{-3}$$

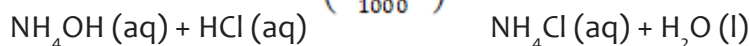

Mole reaction ratio = 1:1, thus moles of NH_4Cl formed = 0.01 moles and moles of ammonia reacted = 0.01 moles.

$$\text{Moles of ammonia unreacted} = 0.032 - 0.01 = 0.022 \text{ moles}$$

$$pOH = -\log(1.8 \times 10^{-5}) + \log\left(\frac{0.01}{0.022}\right) = 5 - \log 1.8 + \log 0.45$$

$$pOH = 4.40$$

$$pH = 14 - 4.40$$

$$**pH = 9.6**$$

(b) Concentration of HCl added = $\left(\frac{0.7 \times 1}{1000}\right) = 0.0007 \text{ mol dm}^{-3}$

The added hydrogen ions from HCl react with ammonia solution, reducing the concentration of ammonia but increasing the concentration of ammonium chloride.

$$\text{New } [NH_4OH] = 0.022 - 0.0007 = 0.0213 \text{ mol dm}^{-3}$$

$$\text{New } [NH_4Cl] = 0.01 + 0.0007 = 0.0107 \text{ mol dm}^{-3}$$

$$pOH = -\log(1.8 \times 10^{-5}) + \log\left(\frac{0.0107}{0.0213}\right) = 5 - \log 1.8 + \log 0.02347$$

$$pOH = 4.44$$

$$pH = 14 - 4.44$$

$$**pH = 9.56**$$

$$pH \text{ change} = 9.6 - 9.56 = \underline{\underline{0.04 \text{ units}}}$$

Lesson 9: Preparation of buffer solutions of different pH

(a) Prerequisites

Learners will understand better buffer solutions preparation if they have prior knowledge about mole concept and concentration of solutions, pH and pOH of acidic and alkaline buffer solutions,

(b) Teaching resources

Use worksheets, textbooks, chalkboard, sodium ethanoate, ethanoic acid, distilled water, beakers, weighing scale, measuring cylinder, Cali-

brated pH meter, Glass rod, and volumetric flask.

(c) Learning activities

As a teacher, you are expected to guide learners through the following steps:

- Arrange your class by putting students into group of 3 or 4 depending on the size of the class and the materials/chemicals available in the laboratory.
- First ask them to discuss and record their answers on worksheets.
- Select a member of each group to present their findings
- Make a summary of the expected answers as you sort out some errors that could have been made by the learners.
- You can continue the discussion to preparation of buffer solutions of different pH
- Then direct two members of each group to collect the chemicals and apparatus from a safe place previously arranged by the lab attendant or technician.
- Supply students books to the groups and make sure they are enough to the group, if possible give each student his/her own copy in the group
- Instruct learners in each group to follow the experimental procedures in the students' book, perform the experiment and record the results on a worksheet.
- Give them enough time to think and discuss about the possible answers.
- Check learners responses and ideas as the lesson progresses.
- Comment on learners' responses and give them a summary of expected feedback based on their findings.

Answers to activity 9.9

Refer to students' book

Answers to checking up 9.9

(a) pH, read it on pH meter during the experiment. It is in range (4.8 – 5.2). Learners must state exactly one that is read.

(b) [Acid] = 0.3 mol dm⁻³

$$[\text{Salt}] = \frac{0.3}{82} = 0.00366 \text{ moles; } 82 \text{ is molar mass of sodium ethanoate}$$

$$[\text{Salt}] = \frac{0.00366 \times 1000}{100} = 0.0366 \text{ mol dm}^{-3}$$

$$\text{pH} = \text{pK}_a + \log \left(\frac{[\text{Salt}]}{[\text{Acid}]} \right)$$

$$\text{pH} = -\log(1.8 \times 10^{-5}) + \log \left(\frac{0.0366}{0.3} \right)$$

$$\text{pH} = 3.8$$

(c) The calculated pH is lower than the experimental pH because there is a big difference in the concentrations of the salt and the base.

Lesson 10: Explanation of the working of buffer solutions

(a) Prerequisites

Students will learn this lesson better if they have knowledge about acidic and basic buffers, reactions of acids and alkalis/base,

(b) Teaching resources

Use a computer, projector, internet, worksheets and buffer solution prepared in the previous lesson.

(c) Learning activities

As a facilitator, you are expected to guide learners to learn by doing activity 9.10 in the students book and discuss the content through the following steps:

- Organize your class by putting students into group of 5 or 6 depending on the size of the class.
- Supply student's books to each group and guide them on the page where to find the activity.
- Let them discuss and use reference books or internet to find answers where they find challenges.
- The activity will guide you and your learners to enter smoothly the working of buffer solutions and their applications in different fields.

- You can provide learners with 1M NaOH and 1M HCl for them to add drops in the buffer solution and note pH changes.
- Choose randomly three representatives from all groups to present their findings.
- Allow some other students to comment about the findings presented by their colleagues.
- Give your feedback highlighting how a given buffer solution works, use equations to clarify your statements.
- Through different small oral questions, help the students to make the conclusions and summaries themselves.
- To check their understanding, give them the checking up activity 9.10 in the student's book as an individual homework.
- The feedback will be given in the next session after marking.

Answers to activity 9.10

Refer to students' book

Answers to checking up 9.10

1. (a)(i) A Bronsted – Lowry acid is a proton donor.
 (ii) $\text{CH}_3\text{COOH (aq)} \rightleftharpoons \text{CH}_3\text{COO}^- \text{(aq)} + \text{H}^+ \text{(aq)}$
 (b) The buffer solution contains a large amount of CH_3COO^- from both the salt and the acid.

When a small amount of the acid is added, the added hydrogen ions are reacted by ethanoate ions to form ethanoic acid. This prevents an increase in concentration of hydrogen ions hence pH remains constant.

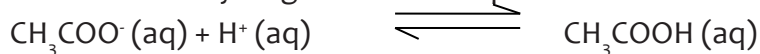

When a small amount of the base is added, the added hydroxide ions react with ethanoic acid to form ethanoate ions and water. This prevents an increase in the concentration of hydroxide ions hence pH remains constant.

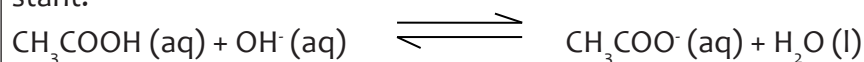

(c) $\text{pH} = \text{pK}_a + \log\left(\frac{[\text{Salt}]}{[\text{Acid}]}\right)$

$$\text{pH} = -\log(1.75 \times 10^{-3}) + \log\left(\frac{0.25}{0.20}\right)$$

$$\text{pH} = 3 - \log 1.75 + \log 1.25$$

$$\text{pH} = 2.85$$

2. So that the buffer solution will have equal capacity to react with either the acid or base added.

3. This is because the ratio, $[\text{A}^-]/[\text{HA}]$ does not change very much. This is true as long as

the amount of strong base or acid added is small compared to the amount of conjugate

acid or conjugate base in the buffer. If you add too of much strong acid or base, you will

exceed the buffer capacity.

4. Buffer capacity is the amount of added acid or base that can be neutralized by the buffer. It is determined by the concentrations of the conjugate base or conjugate acid. Buffer capacity increases as these concentrations increase.

9.6. Summary of the unit

- An acid is a proton donor or any substance which ionizes in aqueous solution to produce hydrogen ions as the only positively charged ions in solution.
- An alkali is substance which ionize in aqueous solution to produce hydroxide ions as the only negatively charged ions in solution.
- An alkali is part of bases. Bases can be oxides or alkalis (hydroxides). Generally, a base is a proton acceptor or an electron pair donor.
- Acids and alkalis are electrolytes which can ionize partially or completely in water.

Those that ionize partially can reach equilibrium and therefore equilibrium law can be applied to get acid or base dissociation constants, K_a or K_b .

- The degree of ionization is the ratio of the number of ionized molecules to the total number of molecules dissolved in water. It is related to equilibrium constant and concentration of the solution by the expression $\alpha = \sqrt{\frac{K}{C}}$
- Acids are given pK_a values: $pK_a = -\log K_a$. The smaller the pK_a value, the stronger the acid. Bases are given pK_b values: $pK_b = -\log K_b$. A stronger base has a smaller pK_b .
- pH is a scale commonly used to measure the degree of acidity or alkalinity of a solution. It is defined as negative logarithm to base 10 of molar hydrogen ion concentration or $pH = -\log_{10} [H^+]$. pOH is the negative logarithm to base 10 of the molar concentration of hydroxide ions in a solution. $pOH = -\log_{10} [OH^-]$. $pH = pK_w - pOH$
- A salt is a substance formed when either part or all the ionisable hydrogen of an acid have been replaced by a metallic ion or ammonium radical. Salt hydrolysis is a reaction in which the cation or anion or both of a salt react with water to form an acidic or alkaline solution.
- Reactions of salts which undergo hydrolysis reach equilibrium and the hydrolysis constant, K_h is given $K_h = \frac{K_w}{K_a}$ or $K_h = \frac{K_w}{K_b}$. K_h is related to K_w , K_a and K_b form the expressions $K_h = \frac{K_w}{K_a}$ or $K_h = \frac{K_w}{K_b}$
- A buffer solution is a solution which resists changes in pH on addition of a small amount of a base or acid.
- The pH of a buffer solution is calculated using the Henderson-Hasselbalch equation given by $pH = pK_a + \log \frac{[Salt]}{[Acid]}$ or $pOH = pK_b + \log \frac{[Base]}{[Salt]}$
- Buffer solutions can be prepared by two methods namely; mixing weak acid and its corresponding salt or weak base and its corresponding salt and the partial neutralization of a base by an acid and vice-versa.
- Buffer solutions have many practical applications such as controlling the pH of human blood constant, maintaining pH of soil for survival of microorganisms and proper growth of plants, a stable pH in water bodies ensures survival of aquatic organisms, used in manufacture of cosmetics and alcohols.

9.7. Additional information for teachers

pH of a solution is the negative logarithm to base ten of the molar hydrogen ion concentration. Hydrogen ions do not exist freely in solutions made using water, they are very small and thus have a high charge. This means that in water, they are solvated. They only exist as hydrated protons or hydrated hydrogen ions i.e. H_3O^+ and is called the oxonium or Hydronium ion or hydroxonium ion or hydronium ion. In this unit, H_3O^+ is used as a hydrogen ion.

Consider the reaction below:



A **conjugate acid** is a species with a hydrogen ion added to it e.g. H_3O^+ while a **conjugate base** is a species formed by the removal of a proton from it e.g. Cl^- . Therefore H_3O^+ and Cl^- form acid-base conjugate pair.

pH provides a quantitative measure of acidity and alkalinity of a solution. For acidic solutions, $[H^+]$ is greater than $[OH^-]$ and pH is less than 7. For alkaline solutions, $[H^+]$ is less than $[OH^-]$ and pH is greater than 7. For neutral solutions, $[H^+] = [OH^-] = 1.0 \times 10^{-7} \text{ mol dm}^{-3}$ and $\text{pH} = 7$.

Pure water is neutral. Mineral water such as Inyange, Nil, Akandi, Aqua sipi, jibu is alkaline. It contains dissolved ions added as water passes through natural rocks such as limestone. Limestone is chemically known as calcium carbonate which reacts with a few hydrogen ions in water forming calcium hydrogen carbonate. This decreases the concentration of hydrogen ions in water thus the overall pH increases. The pH of mineral water is about 7.0 – 8.0.

pH is not a whole number. It is obtained using a calculator as follow. Press – (negative sign), log and then $[H^+]$ value. To get $[H^+]$ value, press SHIFT, log, – (negative sign) and finally pH value or PRESS $10^{-\text{pH}}$ e.g. if the pH is 2, $[H^+] = 10^{-2}$

Considering a property $\log_{10}\left(\frac{a}{b}\right)$ and applying logarithm rules, division becomes subtraction thus becomes $\log_{10}^a - \log_{10}^b$. Also $\log_{10}(x \times y)$, multiplication becomes addition thus becomes $\log_{10}^x + \log_{10}^y$. For a property $\log_{10}^x = A$, to find the value of x given A, $x = 10^A$. For example, $-\log_{10}^{[H^+]} [H^+] = 5.2$, the value of $[H^+] = 10^{-5.2}$. $[H^+]$ is also equal to $\left(\frac{1}{10^{-5.2}}\right)$.

9.8. End unit assessment

Answers to end unit assessment questions

SECTION A:

- | | |
|------|-------|
| 1. A | 6. B |
| 2. A | 7. B |
| 3. C | 8. C |
| 4. D | 9. B |
| 5. D | 10. C |

SECTION B:

11. (a) A weak acid is an electrolyte which is partially ionized in aqueous solutions.

$$(b) K_a = \frac{[C_6H_5COO^-][H^+]}{[C_6H_5COOH]}$$

$$6.4 \times 10^{-5} = \frac{[H^+]}{0.1}$$

$$[H^+] = \sqrt{(6.4 \times 10^{-5}) \times 0.1}$$

$$[H^+] = 2.53 \times 10^{-3} \text{ mol dm}^{-3}$$

$$\text{pH} = -\log_{10} [H^+]$$

$$= -\log_{10}(2.53 \times 10^{-3})$$

$$\text{pH} = 2.6$$



$$K_a = \frac{[\text{CH}_3\text{COO}^-][\text{H}^+]}{[\text{CH}_3\text{COOH}]} = \frac{[\text{H}^+]^2}{c_a}$$

$$[\text{H}^+] = \sqrt{(1.8 \times 10^{-5}) \times 0.1}$$

$$[\text{H}^+] = 1.34 \times 10^{-3} \text{ mol dm}^{-3}$$

$$\text{pH} = -\log_{10}[\text{H}^+]$$

$$\text{pH} = -\log_{10}(1.34 \times 10^{-3})$$

$$\text{pH} = 3 - \log 1.34$$

$$\text{pH} = 2.87$$

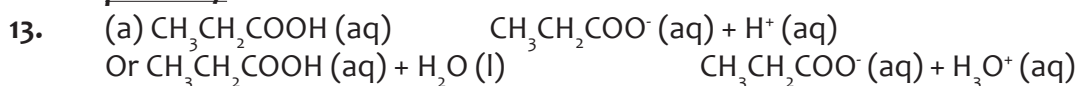

(b) $K_a = \frac{[\text{CH}_3\text{CH}_2\text{COO}^-][\text{H}^+]}{[\text{CH}_3\text{CH}_2\text{COOH}]}$ or $K_a = \frac{[\text{CH}_3\text{CH}_2\text{COO}^-][\text{H}_3\text{O}^+]}{[\text{CH}_3\text{CH}_2\text{COOH}]}$

14. (a) $\text{pH} = -\log_{10}[\text{H}^+]$

$$K_a = \frac{[\text{H}^+]^2}{c_a}$$

$$[\text{H}^+] = \sqrt{(7.4 \times 10^{-4}) \times 0.23}$$

$$[\text{H}^+] = 1.305 \times 10^{-2} \text{ mol dm}^{-3}$$

$$\text{pH} = -\log_{10}[\text{H}^+]$$

$$= -\log_{10}(1.305 \times 10^{-2})$$

$$\text{pH} = 1.88$$

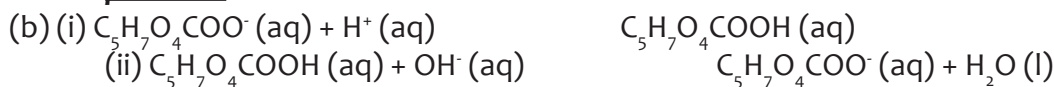

(c) $\text{pH} = \text{p}K_a + \log\left(\frac{[\text{Salt}]}{[\text{Acid}]}\right)$

$$\text{pH} = -\log(7.4 \times 10^{-4}) + \log\left(\frac{0.3}{0.2}\right)$$

$$\text{pH} = 3.3$$

(c) K_w is the ionic product of water or the dissociation constant for water

$$K_w = [\text{H}^+][\text{OH}^-] \text{ or } K_w = [\text{H}_3\text{O}^+][\text{OH}^-]$$

Water has a pH of 7 because it is neutral since the concentration of H^+ ions in water is $1.0 \times 10^{-7} \text{ mol dm}^{-3}$



$$[\text{OH}^-] = c_a$$

$$[\text{OH}^-] = 0.01 \times 0.04 = 4.0 \times 10^{-4} \text{ mol dm}^{-3}$$

$$\text{pOH} = -\log_{10}[\text{OH}^-]$$

$$\text{pOH} = -\log_{10}(4.0 \times 10^{-4})$$

$$\text{pOH} = 3.39$$

$$\text{pH} = 14 - \text{pOH}$$

$$\text{pH} = 14 - 3.39$$

$$\text{pH} = 10.61$$

16. (a) $\text{CH}_3\text{COOH}(\text{aq}) + \text{NaOH}(\text{aq}) \rightleftharpoons \text{CH}_3\text{COONa}(\text{aq}) + \text{H}_2\text{O}(\text{l})$
At half-way neutralization, $[\text{CH}_3\text{COOH}] = [\text{CH}_3\text{COONa}] = 0.05\text{M}$

$$\text{pH} = \text{pK}_a + \log \left(\frac{[\text{Salt}]}{[\text{Acid}]} \right)$$

$$\text{pH} = -\log(1.8 \times 10^{-5}) + \log \left(\frac{0.05}{0.05} \right)$$

$$\text{pH} = 4.7$$

- (b) The pH of the resultant solution does not change i.e. remains at 4.7

Explanation

Ethanoic acid is a weak acid which is only partially ionized while sodium ethanoate is a strong electrolyte and is completely ionized in aqueous solution.

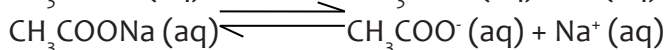
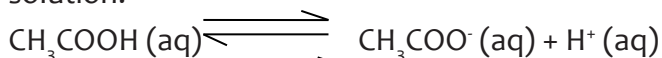

The OH^- ions from the base added combine with hydrogen ions in the solution to form water. However, this increases the ionization of ethanoic acid to re-establish the concentration of hydrogen ions back to normal. Therefore, the pH of the solution remains constant.

17. (a)(i) $\text{CH}_3\text{COO}^-(\text{aq}) + \text{HCl}(\text{aq}) \rightleftharpoons \text{CH}_3\text{COOH}(\text{aq}) + \text{Cl}^-(\text{aq})$
Or $\text{CH}_3\text{COO}^-(\text{aq}) + \text{H}^+(\text{aq}) \rightleftharpoons \text{CH}_3\text{COOH}(\text{aq})$
(ii) $\text{CH}_3\text{COOH}(\text{aq}) + \text{NaOH}(\text{aq}) \rightleftharpoons \text{CH}_3\text{COONa}(\text{aq}) + \text{H}_2\text{O}(\text{l})$
Or $\text{CH}_3\text{COOH}(\text{aq}) + \text{OH}^-(\text{aq}) \rightleftharpoons \text{CH}_3\text{COO}^-(\text{aq}) + \text{H}_2\text{O}(\text{l})$

$$(b) \text{pH} = \text{pK}_a + \log \left(\frac{[\text{Salt}]}{[\text{Acid}]} \right)$$

$$4.5 = -\log(1.8 \times 10^{-5}) + \log \left(\frac{0.2}{[\text{Acid}]} \right)$$

$$4.5 = 5 - \log 1.8 + \log 0.2 - \log [\text{Acid}]$$

$$\log [\text{Acid}] = -0.4543$$

$$[\text{Acid}] = 0.35 \text{ mol dm}^{-3}$$

$$(b) K_b = \frac{[\text{OH}^-]^2}{c_b}$$

$$K_b = \frac{(4.0 \times 10^{-4})^2}{0.01}$$

$$K_b = 1.6 \times 10^{-5} \text{ mol dm}^{-3}$$

18. (a) $K_b = \frac{[\text{NH}_4^+][\text{OH}^-]}{[\text{NH}_4\text{OH}]}$

$$(b) K_b = \frac{[\text{OH}^-]^2}{c_b}$$

$$[\text{OH}^-] = \sqrt{(1.8 \times 10^{-5}) \times 0.1}$$

$$[\text{OH}^-] = 1.34 \times 10^{-3} \text{ mol dm}^{-3}$$

Assumptions

$[\text{NH}_4^+] = [\text{OH}^-]$; since there is negligible OH^- ions from water and the mole reaction ratio $\text{NH}_4^+ : \text{OH}^-$ is 1:1

$[\text{NH}_4^+] = 0.1\text{M}$ since little of NH_4OH has ionized in solution

$$(c) K_b = \frac{[\text{NH}_4^+][\text{OH}^-]}{[\text{NH}_4\text{OH}]}$$

$[\text{NH}_4^+] = 0.01 \text{ mol dm}^{-3}$, Since NH_4Cl fully ionizes to NH_4^+ ions in solution

$[\text{NH}_4\text{OH}] = 0.1 \text{ mol dm}^{-3}$, poorly ionizes in solution

$$K_b = \frac{0.01 \times [\text{OH}^-]}{0.1}$$

$$[\text{OH}^-] = \frac{(1.8 \times 10^{-5}) \times 0.1}{0.01}$$

$$[\text{OH}^-] = 1.8 \times 10^{-4} \text{ mol dm}^{-3}$$

$$\text{Change in } [\text{OH}^-] = (1.34 \times 10^{-3}) - (1.8 \times 10^{-4})$$

$$= 1.16 \times 10^{-3} \text{ mol dm}^{-3}$$

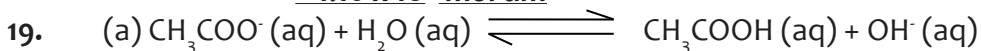

$$(b) K_h = \frac{[\text{CH}_3\text{COOH}][\text{OH}^-]}{[\text{CH}_3\text{COO}^-]}$$

$$(c)(i) K_h = \frac{K_w}{K_a}$$

$$= \frac{1.0 \times 10^{-14}}{1.8 \times 10^{-5}}$$

$$= 5.56 \times 10^{-10} \text{ mol dm}^{-3}$$

$$(ii) K_h = \frac{[\text{OH}^-]^2}{c_s}$$

$$[\text{OH}^-] = \sqrt{(5.56 \times 10^{-10}) \times 0.1}$$

$$[\text{OH}^-] = 7.46 \times 10^{-6} \text{ mol dm}^{-3}$$

$$\text{pOH} = -\log_{10} [\text{OH}^-]$$

$$\text{pOH} = -\log_{10} (7.46 \times 10^{-6})$$

$$\text{pOH} = 5.13$$

$$\text{pH} = 14 - \text{pOH}$$

$$\text{pH} = 14 - 5.13$$

$$\text{pH} = 8.87$$

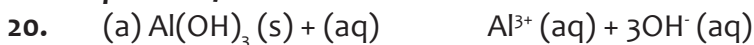

(b) From the equation, $[\text{Al}(\text{OH})_3] = [\text{Al}^{3+}] = 3[\text{OH}^-]$

$$[\text{OH}^-] = 3 \times (2.3 \times 10^{-3})$$

$$[\text{OH}^-] = 6.9 \times 10^{-6} \text{ mol dm}^{-3}$$

$$K_w = [\text{H}^+][\text{OH}^-]$$

$$[\text{H}^+] = \frac{K_w}{[\text{OH}^-]} = \frac{1.0 \times 10^{-14}}{6.9 \times 10^{-6}}$$

$$[\text{H}^+] = 1.45 \times 10^{-9} \text{ mol dm}^{-3}$$

$$\text{pH} = -\log_{10} [\text{H}^+]$$

$$\text{pH} = -\log_{10}(1.45 \times 10^{-9})$$

$$\text{pH} = 8.84$$

For answers to (c) and (d), refer to students' book

9.9. Additional activities

Remedial activities	
<p>Question 1 What is the pH of a solution containing 0.004M HClO₄?</p>	<p>Answer 1 $\text{pH} = -\log[\text{H}^+]$ $= -\log(0.004)$ pH = 1.4</p>
<p>Question 2 Calculate the concentration of Mg²⁺ ions in a solution of Mg(OH)₂ whose pH is 10.62</p>	<p>Answer 2 $\text{pOH} = 14 - \text{pH} = 14 - 10.62$ $\text{pOH} = 3.38$ $\text{pOH} = -\log[\text{OH}^-]$ $[\text{OH}^-] = \log^{-1}(3.38)$ $[\text{OH}^-] = 4.17 \times 10^{-4} \text{ mol dm}^{-3}$ $\text{Mg(OH)}_{2(\text{aq})} \rightleftharpoons \text{Mg}^{2+}_{(\text{aq})} + 2 \text{OH}^{-}_{(\text{aq})}$ Mole ratio Mg(OH)₂: OH⁻=1:2 thus $[\text{Mg(OH)}_2] = [\text{Mg}^{2+}] = \frac{1}{2} \times 4.17 \times 10^{-4}$ $[\text{Mg}^{2+}] = 2.08 \times 10^{-4} \text{ mol dm}^{-3}$</p>
<p>Question 3 The K_a of ethanoic acid is 1.8 x 10⁻⁵ mol dm⁻³ at room temperature. Calculate the pK_a of the acid.</p>	<p>Answer 3 $\text{pK}_a = -\log K_a$ $\text{pK}_a = -\log(1.8 \times 10^{-5})$ $\text{pK}_a = 4.75$</p>
<p>Question 4 The pH of aqueous ammonium chloride is less than 7 while that of sodium chloride is 7. Explain this observation.</p>	<p>Answer 4 Ammonium chloride is a salt of weak base and strong acid thus undergoes hydrolysis to produce a high concentration of hydrogen ions in solution hence pH is less than 7. $\text{NH}_4\text{Cl}_{(\text{aq})} + \text{H}_2\text{O}_{(\text{l})} \rightleftharpoons \text{NH}_4\text{OH}_{(\text{aq})} + \text{HCl}_{(\text{aq})}$ Or $\text{NH}_4^+_{(\text{aq})} + \text{H}_2\text{O}_{(\text{l})} \rightleftharpoons \text{NH}_4\text{OH}_{(\text{aq})} + \text{H}^+_{(\text{aq})}$ In contrast, sodium chloride being a salt of strong base and strong acid, it ionizes in water to form equal concentrations of hydrogen ions and hydroxide ions. Therefore pH will be 7 (resultant solution is neutral)</p>

Consolidation activities

Question 1

What volume of NaOH of pH 11.30 is required to neutralize 20 cm³ of CH₃COOH of pH 2.1 (K_a of CH₃COOH is 1.8 x 10⁻⁵ and K_w = 1 x 10⁻¹⁴ mol dm⁻³)

Answer 1

From pH of NaOH, pOH = 14 - 11.30 = 2.70

$$[\text{OH}^-] = 10^{-2.70}$$

$$[\text{OH}^-] = [\text{NaOH}] = 2.0 \times 10^{-3} \text{ mol dm}^{-3}$$

For ethanoic acid, $[\text{H}^+] = 10^{-2.10} = 7.94 \times 10^{-3} \text{ mol dm}^{-3}$,

$$[\text{CH}_3\text{COOH}] = C_a = \frac{[\text{H}^+]^2}{K_a} = 3.5 \text{ M}$$

$$\text{Moles of acid} = \left(\frac{3.5 \times 20}{1000} \right) = 0.07 \text{ moles}$$

Moles of NaOH = 0.07 moles, mole ratio 1:1

$$\text{Volume of NaOH} = \left(\frac{0.07 \times 1000}{2.0 \times 10^{-3}} \right) = 3.5 \times 10^4 \text{ cm}^3$$

Question 2

Explain why the pH of water decreases when it is left standing in air for a long time.

Answer 2

Water absorbs carbon dioxide from the atmosphere which dissolves to form a weak acid called carbonic acid. The acid ionizes partially to produce hydrogen ions responsible for the acidity/reduction in pH

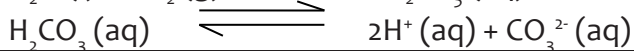
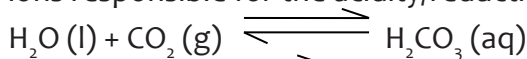

Question 3

Given that the pK_a of ammonia at 25 °C is 9.25. Calculate the pH of 0.1M ammonia solution.

Answer 3

$$\text{pK}_a + \text{pK}_b = \text{pK}_w$$

$$\text{pK}_b = 14 - 9.25 = 4.75$$

$$\text{pK}_b = -\log K_b$$

$$K_b = \log^{-1}(4.75) = 1.75 \times 10^{-5} \text{ mol dm}^{-3}$$

$$[\text{OH}^-] = \sqrt{(1.75 \times 10^{-5}) \times 0.1}$$

$$[\text{OH}^-] = 1.33 \times 10^{-3} \text{ mol dm}^{-3}$$

$$\text{pOH} = -\log [\text{OH}^-] = -\log (1.33 \times 10^{-3})$$

$$\text{pOH} = 2.9$$

$$\text{pH} = 14 - 2.9$$

$$\text{pH} = 11.10$$

Extended activities

Question 1

(a) Ethanoic acid is a weak acid.

(i) Explain what is meant by a weak acid?

(ii) Calculate the pH of a 0.05M ethanoic acid solution of K_a 1.8×10^{-5} mol dm⁻³.

(b)(i) Explain what is meant by a buffer solution?

(ii) Discuss how a buffer solution works.

(c) A solution was made by dissolving 7.2g of ethanoic acid and 12.0g of sodium ethanoate to make one litre. To the solution was added 0.8 cm³ of 1M hydrochloric acid. Calculate the pH of the solution. State any assumptions you will make

Answer 1

(a)(i) Refer to student's book

$$(ii) K_a = \frac{[H^+]^2}{C_a}$$

$$[H^+] = \sqrt{(1.8 \times 10^{-5}) \times 0.05}$$

$$[H^+] = 9.487 \times 10^{-3} \text{ mol dm}^{-3}$$

(b) (i) and (ii), Refer to student's book

(c) Moles of HCl added = $\left(\frac{0.8 \times 1}{1000}\right) = 8 \times 10^{-4}$ moles

Molar mass of CH₃COOH = 60g/mol

$$[CH_3COOH] = 7.2/60 = 0.12 \text{ mol dm}^{-3}$$

Molar mass of CH₃COONa = 82g/mol

$$[CH_3COONa] = 12/82 = 0.146 \text{ mol dm}^{-3}$$

Addition of HCl increases [CH₃COOH] and reduces [CH₃COONa]

$$\text{New [Acid]} = 0.12 + 8 \times 10^{-4} = 0.1208 \text{ mol dm}^{-3}$$

$$\text{New [Salt]} = 0.146 - 8 \times 10^{-4} = 0.1452 \text{ mol dm}^{-3}$$

$$pH = pK_a + \log\left(\frac{[Salt]}{[Acid]}\right)$$

$$pH = -\log(1.8 \times 10^{-5}) + \log\left(\frac{0.1452}{0.1208}\right)$$

$$pH = 4.82$$

<p>Question 2</p> <p>The molar conductivity of a 0.05M solution of benzoic acid at 25 °C is $9.46 \times 10^{-4} \text{ ohm}^{-1}\text{cm}^2 \text{ mol}^{-1}$. If the molar conductivities at zero concentrations of H^+ and $\text{C}_6\text{H}_5\text{COO}^-$ ions are 2.8×10^{-2} and $6.0 \times 10^{-3} \text{ ohm}^{-1} \text{ cm}^2 \text{ mol}^{-1}$. Calculate:</p> <p>(a) the degree of dissociation of acid (b) the acid dissociation constant (c) the pH of the solution</p>	<p>Answer 2</p> <p>(a) Λ_{∞} = sum of molar conductivities of ions $\Lambda_{\infty} = \Lambda_0(\text{H}^+) + \Lambda_0(\text{C}_6\text{H}_5\text{COO}^-)$ $\Lambda_{\infty} = (2.8 \times 10^{-2}) + (6.0 \times 10^{-3})$ $\Lambda_{\infty} = 3.4 \times 10^{-2} \text{ ohm}^{-1} \text{ cm}^2 \text{ mol}^{-1}$ Degree of dissociation</p> $\alpha = \left(\frac{\text{Molar conductivity at conc. } C}{\text{Molar conductivity at infinite dilution}} \right)$ $\alpha = \left(\frac{9.46 \times 10^{-4}}{3.4 \times 10^{-2}} \right) = 2.78 \times 10^{-2}$ <p>(b) $K_a = C\alpha^2 = 0.05 \times (2.78 \times 10^{-2})^2$ $K_a = 3.86 \times 10^{-5} \text{ mol dm}^{-3}$</p> <p>(c) $[\text{H}^+] = C\alpha = 0.05 \times (2.78 \times 10^{-2})$ $[\text{H}^+] = 1.39 \times 10^{-3} \text{ mol dm}^{-3}$</p> <p>Or $[\text{H}^+] = \sqrt{K_a \cdot C_a}$ $[\text{H}^+] = \sqrt{3.86 \times 10^{-5} \times 0.05}$ $[\text{H}^+] = 1.39 \times 10^{-3} \text{ mol dm}^{-3}$ $\text{pH} = -\log [\text{H}^+]$ $\text{pH} = -\log (1.39 \times 10^{-3})$ $\text{pH} = 2.86$</p>
<p>Question 3</p> <p>Explain why the acid dissociation constant, K_a of bromoethanoic acid is greater than that of ethanoic acid at the same temperature.</p>	<p>Answer 3</p> <p>Acid dissociation constant is a measure of the strength of acids and depends on the ease with which a proton/hydrogen ion is lost in solution bromoethanoic acid is a strong acid because of highly electronegative bromine attached to α-carbon which strongly pulls electrons away from α-carbon. The effect is transmitted in the O – H bond weakening it. This facilitates easy release of hydrogen ions in solution.</p> <p>In ethanoic acid, the methyl group has a positive inductive effect which pushes electrons towards the carbonyl carbon. This effect is transmitted to the O – H bond which makes it strong and difficult to release hydrogen ions in solution.</p>

UNIT 10: INDICATORS AND TITRATION CURVES

10

10.1. Key unit competence

Learners should be able to relate titration curves to the type of acid and base titrated, properly choose and use indicators in acid-base titration

10.2. Prerequisites

Students will learn better indicators and titration curves if they have knowledge on, Acids and bases, mole concept and concentration of solutions, titration, dissociation of strong and weak acids and bases and the pH scale. A knowledge of how to use laboratory apparatus is also important.

The teacher will discuss with learners by asking them questions to check whether they still recall what they studied in the previous chapters

10.3. Cross-cutting issues to be addressed

a. Inclusive education

This unit involves a number of experiments on acid and bases to be performed in the laboratory. To be able to understand it, there must be discussions and sharing of information among learners. You can organize your learners and use different strategies to help all learners understand concepts very well. Some of the strategies to be used are provided in the introductory part of this book.

b. Gender

Encourage both boys and girls to form mixed groups and equally participate in their discussions, experiments, and presenting their findings to the whole class.

c. Financial education

As this unit deals with chemicals which are consumables and very expensive, the teacher should advise learners to use chemicals effectively without wastage. Improvisation where possible can be done to reduce the cost. For examples, use of flower extracts for indicators, use of lemon juice for acid, use of dried banana and Irish potato peels which are grounded to get a basic solution instead of sodium hydroxide.

d. Peace and values

During group activities, the teacher will encourage learners to help each other by sharing ideas, apparatus and chemicals, students' books and other reference books. Learners should be encouraged to work together and respect each other's opinions.

Setting up and manipulation of apparatus involves participation of all students; the teacher is supposed to assist them where possible.

10.4. Guidance on the introductory activity

- You will guide students to form groups of 3 to 4 (mixing both girls and boys) depending on the materials and apparatus in the school and the laboratory.
- Guide students to find the introductory activity in students' book and discuss the differences between acids and bases giving specific examples.
- Learners should mention food substances that contain acids such as fruits.
- Students to differentiate between weak and strong acids basing on their ionization properties.
- Learners to explain the difference between pH and equivalence point.
- The teacher should ask Learners questions related to the previous units of titrations of acids and bases, changes of indicators at end point, and final products of neutralization.
- The teacher should remind learners about the methods of handling apparatuses in the laboratory and how to set up apparatus for titration.
- You will finally guide learners to make a summary of the expected answers.

Expected answers for the introductory activity

1. An acid is a proton donor or an electron pair acceptor or a substance which ionizes/dissociates in aqueous solution to produce hydrogen ions as the only positively charged ions in solution.

A base is a proton acceptor or an electron pair donor or a substance which ionizes/dissociates in aqueous solution to produce hydroxyl/hydroxide ions as the only negatively charged ions in solution.

2. The equivalence point tells us when enough acid or base has been added to neutralize the solution, while the end point is a point when the indicator changes colour. A good choice of the indicator will change colour near or at the equivalence point.

10.5. List of lessons

#	Lessons tittle	Learning objective	Number of periods.
1	Definition of acid-base indicator.	Define the term indicator	1
2	Explanation of the working of indicators, the pH range of indicators and choice of indicators in titration.	Explain how indicators work under different pH in acid—base titration.	2

3	Acid – base titration curves	Explain what is meant by the pH range of indicator. State the criteria for the selection of acid-base indicator for the use in titrations. Describe the changes in pH during acid/base titrations.	3
4	End unit assessment		1

Lesson 1: Definition of acid – base indicator

It is a single lesson of 40 minutes, it should cover the introduction of the whole unit.

a. Prerequisite

Students will learn better the definition of acid-base indicator if they have the understanding on: The concept of acids and bases, pH of different solutions, titration or volumetric analysis.

b. Teaching resources

- Solutions of NaOH and HCl,
- Indicators such as methyl orange and phenolphthalein,
- Litmus papers,
- Lemon juice,
- Pure water,
- Protective grooves.

c. Learning activities

Before learners attempt the activity, first give them precautions on handling chemicals especially acidic solution.

As a facilitator, you are expected to guide learners through the following steps:

Methodological steps

- Organize your class by putting students into group of 4 to 6 depending on the size of the class and the chemicals and apparatus that are available.
- Supply each group materials and apparatus and guide them on the instructions.
- Let learners follow the given instructions and perform the experiment, note observations.
- Give them enough time to think and discuss about the possible answers.
- Check learners' responses and ideas, continue the discussions with a brief brainstorming on the content using students' book.

- Comment on learners' responses and give them the summary of expected feedback.

Expected answers for activity 10.1

Indicator	Colour in base	Colour in acid
Phenolphthalein	Pink	Colourless
Methyl red	Yellow	Red
Litmus paper	Blue	Red
Methyl orange	Yellow	Red
	Red	

Checking up

Expected answers to checking up 10.1

1. After cleaning the burette there is water which remains on the sides of the burette, this would alter the concentration of the solution (acid or base) during titration and lead to poor results.
2. You need to keep the solutions thoroughly mixed in the reaction vessel.
3. The eye should be in line with the meniscus so that proper volumes of acid or base are recorded.

Lesson 2: pH of indicators

a. Prerequisites

Learners will learn and understand the pH range of different indicators if they have knowledge on unit 9 concerning pH of acidic and alkaline solution, the mole concept and concentration of solution.

b. Teaching resources

Universal indicator, Solutions of sodium hydroxide and hydrochloric acid, litmus, phenolphthalein, methyl red and methyl orange indicators.

c. Learning activities

Before introducing the lesson with content, let learners attempt activity 10.2 from the student's book on their own.

As a facilitator, you are expected to guide learners through the following steps:

Methodological steps

- Organize your learners by putting them into group of 3 or 4 depending on the size of the class.
- Provide learners with student's books and guide them on the page where they can find the activity and discuss the questions.
- Give them enough time to think and discuss about the possible answers.

- Check learners' responses and ideas, continue the discussions with a brief brainstorming of the content.
- Comment on learners' responses and give them the summary of expected feedback based on their findings.

Expected answers for activity 10.2

1. Weak acids and bases ionize partially in aqueous solutions. They are classified as weak electrolytes.
2. Strong acids and strong bases ionize fully/completely in aqueous solutions. They are classified as strong electrolytes.
3. A conjugate base is a species which can accept a proton.

Examples i.) HCl and Cl⁻

HCl is an acid and Cl⁻ is a conjugate base.

ii.) NH₄⁺ and NH₃.

NH₄⁺ is an acid and NH₃ is a conjugate base.

(d) Checking up

Expected answers to activity 10.2

1. $\text{HClO}_2(\text{aq}) \rightleftharpoons \text{H}^+(\text{aq}) + \text{ClO}_2^-(\text{aq})$

$$K_a = \frac{[\text{H}^+][\text{ClO}_2^-]}{[\text{HClO}_2]}$$

2. The solution of a weak acid has low concentration of product ions and relatively high concentration of reacting molecule of acid, since equilibrium constant expression involves the concentration of products over concentration of reactants, K_a for any weak acid has a small value.

Lesson 3: Acid – Base titration curves

a. Prerequisites

The learners will require knowledge on the following concepts, titration of a strong acid and a strong base, titration of a weak acid and a weak base and titration of a weak acid and a strong base, knowledge on plotting graphs from physics or mathematics,

b. Teaching resources

Learners only need to use a ruler, graph papers to sketch and finally plot the graphs/curves.

c. Learning activities

The activity requires learners to be extra careful in their discussion and therefore, you will guide them as follow:

Methodological steps

- You will group learners into pairs (a boy and a girl where applicable).
- Provide them with student's books and guide them on the page where the activity is located.
- Ask them to discuss, present their findings. You will iron out some issues and they take a summary of the facts.

Expected answers for activity 10.3

The pH of an known solution changes dramatically around the equivalent point. Acid base indicators measure the pH changes so they change colour quickly at the equivalence point.

Expected answers for checking up 10.3

(a) Volume of acid used = $44.25 - 1.55 = 42.70 \text{ dm}^3$

Volume of base used = $32.50 - 0.75 = 30.75 \text{ dm}^3$

The acid is less concentrated than the base so the molarity will be less than 0.383M

We know this because at the end point (equivalence point) we assume that number of moles of HCl is equal to number of moles of NaOH



Since the number of moles of acid was contained in a larger volume than the base (42.70 dm^3) Vs 31.75 dm^3) the acid must be less concentrated than the base

(b) Moles of NaOH = $(0.383 \text{ mol/dm}^3) \times (0.03175 \text{ mol}) = 0.01216 \text{ mol NaOH}$

Number of moles of HCl = 0.01216 mol (moles of acid and base are equal)

$$[\text{HCl}] = \frac{0.01216}{0.04270} = 0.285\text{M}$$

10.6. Summary of the unit

An indicator is a substance which is used to determine the end point in a titration.

The substances that change colour when the acidity of the solution changes, are known as *acid-base indicators*.

Acid-base indicators are used to find out the equivalence point of a titration. They change their color within a certain pH range.

Weak acids or weak bases are classified as weak electrolytes which ionize partially in solution while strong acids or strong bases as strong electrolytes which ionize completely.

Titration curves for weak acids and strong bases differ from strong acid and strong base titration curves.

Titration curve is normally a plot of pH versus volume of titrant. It shows how the pH of an acid or base change as it is neutralized.

The initial pH is higher in weak acid versus strong base titration

The pH at equivalence point is above 7 for weak acid versus strong base titration

10.7. Additional information for teachers

Since pH changes rapidly near the equivalence point, testing the pH with acid-base indicator can tell us when the solution has reached the equivalence point.

Titration can result into acidic, basic or neutral solutions at the equivalence point.

Examples

Strong acid titrated with strong base results into a neutral solution at equivalence point.

Weak acid titrated with strong base results into basic solutions at equivalence point.

Strong acid titrated with weak base results into acid solutions at the equivalence point.

10.8. End unit assessment

Expected answers to summative assessment

1. The first thing to realize is that the equation given only shows the essential reacting species. K^+ and Na^+ ions really have nothing to do with the actual reaction that takes place KHP and NaOH.

The next thing to realize is that KHP and NaOH react with each other in 1:1 mole ratio.

Then you have to realize that even though potassium ions have nothing to do with the reaction, it must be included when you determine the molar mass of KHP when you weigh out 4.878g sample.

Molar mass, $KHC_8H_4O_4 = 204.1 \text{ g/mol}$

Moles of $KHC_8H_4O_4 = 0.0141 \text{ moles}$

Moles of NaOH = 0.0141 mol

Therefore, concentration of NaOH = 0.596M

2. B, E, F, H and I

3. (a) Methyl Yellow $pK_{in} = 3.5$.

(b) Cong Red $pK_{in} = 4.0$

10.9. Additional activities

Titration can result in acidic, basic, or neutral solutions at the equivalence point.

Titration of a strong acid with some strong base results in a neutral solution at the equivalence point.

10.9.1 Remedial activity

Questions

1. What is a good definition of an indicator?
2. Consider weak acid indicators. Why do different indicators change colour over different pH changes?
3. Suppose a weak acid indicator had $K_a = 8.3 \times 10^{-6}$. Around what pH would you expect it to change colour.

Answers

1. An indicator is a weak acid or base whose molecular form is one colour while its ionic form is another colour.
2. Different indicators change colour over a small pH range on either side of the numerical value for $-\log K_a$ for that indicator. Since different indicators have different values for their ionization constants, they will change colour over different pH ranges.
3. It should change colour around a $\text{pH} = -\log(8.3 \times 10^{-6})$ or 5.08

10.9.2. Consolidation activity

Questions

1. What was the comical “ME STRONG ACID; me weak base” joke designed to help the learners.
2. From the following lists, select the indicator that would be most appropriate for each of the titrations listed.

Titrations

A: 1M HNO_3 titrated with 1M NaOH

B: 1M $\text{HC}_2\text{H}_3\text{O}_2$ with 1M KOH

C: 1M NH_3 with 1M HCl

Indicators

a. Methyl red: changes colour from pH 4.4 – 6.2

b. Litmus: changes colour from pH 5 – 8

c. Alizarin yellow: changes colour from pH 10 – 12

3. Suppose you were to titrate 1M solution of a weak acid like acetic acid ($\text{HC}_2\text{H}_3\text{O}_2$) with a strong base like potassium hydroxide. Select all the true statements from among the following.

A. The pH of the initial acid solution would be the same as it would be if your starting solution was 1M HCl since both are 1M solutions.

B. The pH would still rise slowly at the beginning of the titration.

C. The pH at the equivalence point would be below 7.

D. The pH at the equivalence point would be greater than 7.

E. The pH of the equivalence point rises just as much and just as rapidly as it did when we were titrating HCl with NaOH.

F. The pH of the equivalence point rises rapidly, but not quite as much as it did when we titrated sodium hydroxide and hydrochloric acid.

4. Explain the following observations that phenolphthalein indicator can be used to determine the end-point in the titration of ethanoic acid with sodium hydroxide but methyl orange is not used.

Answers

1. When you titrate a strong acid with a weak base, the solution at the equivalence point is still somewhat acidic and vice versa.

2. A b (litmus)

B c (alizarin yellow)

C a (methyl red)

3. A False

B. True

C. False

D. True

E. False

F. True

4. Ethanoic acid reacts with sodium hydroxide to form sodium ethanoate, a salt of a weak acid-strong base or alkali. This salt undergoes hydrolysis to form an excess hydroxyl ions and ethanoate ions. Therefore, at the end of titration, the resultant solution will be alkaline.

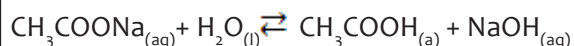
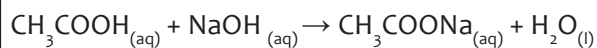

Now, phenolphthalein indicator, being a weak acid, it ionizes in water to establish the following equilibrium

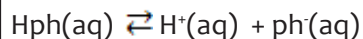

Colourless Pink

The excess hydroxyl ions will react with H^+ ions to form water, and this will disturb the equilibrium position, such that, more phenol (which is colourless) ionizes into the pink form. Hence, effectively showing the end point of the reaction by formation of pink colour.

In contrast, methyl orange being a weak base, will not react with the excess hydroxyl ion in solution. Therefore, will not show any colour change at the end of the reaction.



10.9.3. Extended activity

1. To study a titration curve, 10 ml of 1M NaOH solution were titrated with 1M HCl.

a. Copy and complete the table below:

Volume of HCl added during titration	pH of the solution in the titrated solution
0.00 ml	
2.00 ml	
5.00 ml	
8.00 ml	
9.90 ml	
9.99 ml	
10.00 ml	
10.01 ml	
10.10 ml	
15.00 ml	
18.00 ml	
20.00 ml	

- b. Plot the titration curve (added volume of HCl: x-axis, pH: y-axis).
 c. The following are indicators with their pH change range.

Indicator	pH change range
A	1.2 – 2.8
B	5.8 – 7.8
C	8.3 – 10.0

i) Which one of these indicators must not be used in the titration of NaOH (strong base) with HCl (strong acid)?

ii) Explain your choice.

2.(a) Hydrochloric acid was added to 25 cm³ of 0.1 M ammonia solution and pH of the solution was measured at intervals. The data obtained are given in the table below:

Volume of hydrochloric acid (cm ³)	10	15.0	16.5	17.0	20.0	25.0
pH of the mixture	9.08	8.30	6.70	2.97	19.6	1.60

i) Plot a graph pH against volume of hydrochloric acid

ii) Explain the shape of graph.

iii) Calculate the molarity of the hydrochloric acid.

(b) The pH ranges of some indicators are given below:

Indicator	pH range
Thymol blue	1.2-2.8
Methyl red	4.8-6.0
Phenolphthalein	6.6-8.0

Which one of the above indicators is most suitable for use in the above titration?

Give reasons for your answers

3. a) Draw diagrams to show the change in pH when a 0.1M sodium hydroxide solution is added in portions to:

i) 20 cm³ of 0.1M hydrochloric acid.

ii) 20 cm³ of 0.1M ethanoic acid.

b) Explain the shapes of the curves in (a)

Answers

1.

a. The volume of HCl on the equivalent point: $NaVa = \frac{NbVb}{Na} = \frac{1 \times 10}{1} = 10 \text{ cm}^3$

Before the equivalent point, the solution is basic, then:

pH before the equivalence point = $14 + \log \frac{NbVb - NaVa}{Va + Vb} = 14 + \log$

After the equivalence, the solution is acid, then:

pH = $-\log \frac{NaVa - NbVb}{Va + Vb}$

Volume of HCl added during titration	pH of the solution in the titrated solution
0.00 ml	pH = $14 + \log \frac{NbVb}{Vb}$ or pH = $14 + \log Cb = 14 + \log 1 = 14$
2.00 ml	pH = $14 + \log \frac{NbVb - NaVa}{Vb + Va}$ pH = $14 + \log \frac{10 - 2}{12} = 13.82$
5.00 ml	13.52
8.00 ml	13.04
9.90 ml	11.70
9.99 ml	10.70
10.00 ml	7.00 (EP)
10.01 ml	pH = $-\log \frac{NaVa - NbVb}{Va - Vb}$ = $-\log \frac{10.01 - 10}{20.01} = 3.30$
10.10 ml	2.30
15.00 ml	0.70
18.00 ml	0.55
20.00 ml	0.48

b. Curve

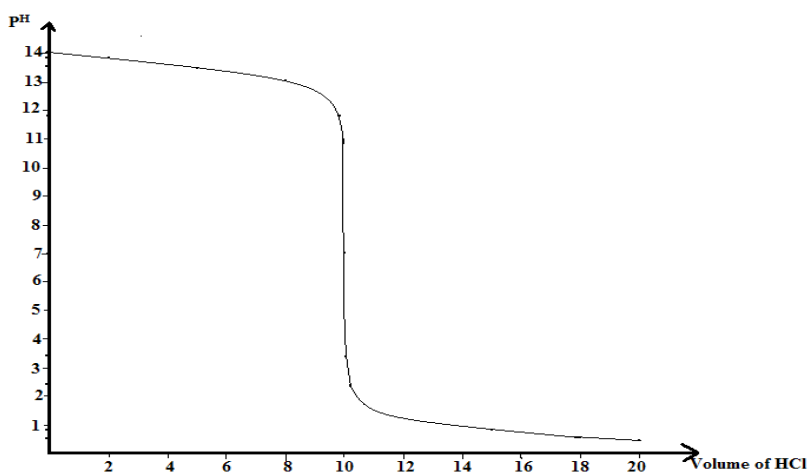

- c. i) The indicator which must not be used in the titration is A
 ii) Because its pH change range, is out of the steepest part of the pH variation curve. Or its pH change range does not cut the steepest part of the pH variation curve.
2. (a) (i) Note that the graph must have the title/ heading, axes labelled with units, and a correct scale.
 ii) Before addition of any acid, the pH is high due to the high concentration of the ammonia solution, which alkaline or basic.

On addition of the acid, the pH gradually decreases as the bases is being partially neutralized by the acid to form a salt. This also formed together with the excess base constitutes a buffer which resists any further change in pH.

At the end point of the titration, pH sharply decreases even with a small amount of the acid added, because all the base is completely neutralized to form NH_3Cl salt.

The pH at the end point is below 7 because the NH_3Cl salt formed is a salt of weak-strong acid thus undergoes hydrolysis leaving an excess of the H^+ or H_3O^+ ions in solution. Hence the resultant solution will be acidic, i.e., pH below 7

After the end point, the pH decreases gradually due to excess hydrochloric acid, which is added.

- iii) The volume of the acid needed for complete neutralization of the acid or the volume needed to reach the end point of the titration is 17.0 cm^3 (from the graph).



Number of moles of the $\text{NH}_3(\text{aq})$ used = 2.5×10^{-3} moles

But 1 mole of the acid reacts with 1 mole of the base to form 1 mole of a salt, thus:

17.0 cm^3 of the acid that reacted contain 2.5×10^{-3} moles

1000 cm^3 of the solution will contain $s = 0.147 \text{ M}$. Therefore, the molarity of hydrochloric acid used is 0.147 M .

- (b) The most suitable indicator would be methyl red. This because the pH ranges at the end of titration is 5.0, which is the working range of methyl red.
3. a) i) Change in pH during titration of a strong acid with a strong base

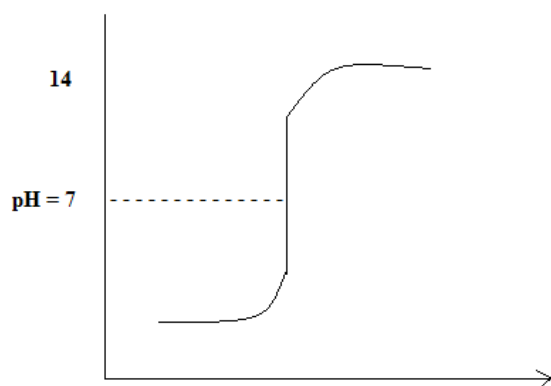

ii) Change of pH during titration of a weak acid with a strong base

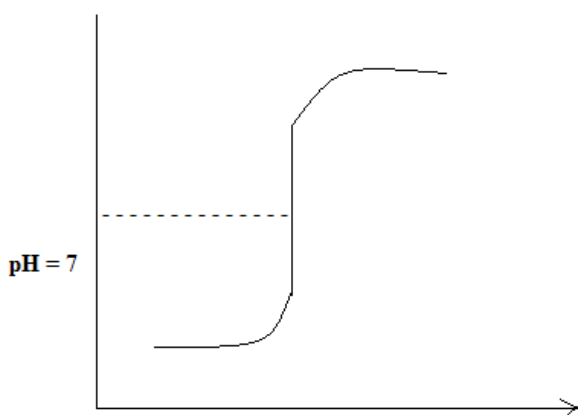

b) Titration of hydrochloric acid with sodium hydroxide:

Initially before addition of the base, pH of the solution is very low due to a high concentration of H^+ ions produced from complete ionization of hydrochloric acid which is a strong acid. On addition of base, the pH increases gradually due to the excess acid still present after partial neutralization of the H^+ ions by OH^- ions of the base.

At the end point, a small amount of the base added results into a sharp rise in pH because all the acid has been completely neutralized to form a neutral salt (NaCl). The pH at the end point is exactly at 7 because the salt formed undergoes on hydrolysis hence the equilibrium between OH^- and H^+ remains undisturbed.

After the end point, pH increases gradually due to excess base or excess sodium hydroxide added.

Titration of hydrochloric acid with ammonia

Initially before addition of any base, pH is low but slightly higher than in (a) i) because ethanoic acid is a weaker acid and does not completely ionize in solution.

After addition of a base, the pH rises gradually because of the un neutralized acid still present and this combines together with the sodium salt of the acid formed, constitutes

a buffer solution which resist any further increase in pH.

At the end point of the titration, pH rises sharply even with a small base added because all the acid has gone to complete neutralization by the base to form a CH_3COONa salt.

The pH at the end point is above 7 because the CH_3COONa salt formed after complete neutralization is a salt of a weak acid and strong base thus, undergoes hydrolysis leaving an excess of the OH^- ions in solution. Hence the resultant solution being basic or alkaline. After the end point, the pH rises gradually due to excess sodium hydroxide or a base added.

UNIT 11: SOLUBILITY AND SOLUBILITY PRODUCT OF SPARINGLY SOLUBLE SALTS

11

11.1. Key unit competence

To be able to calculate the solubility product constant of sparingly soluble salts and deduce the applications of common ion effect in the industry.

11.2. Prerequisite

Learners will understand solubility and solubility better when they have knowledge from laboratory and safety apparatus, solutes, solvents and solution, acids, bases and pH, salts and their properties, the mole concept and concentration of solutions, and titration.

11.3. Cross-cutting issues to be addressed

- **Environment and sustainability**

When salutes (salts) are dissolving in water (a common solvent), they dissociate into ions. Some ions hydrolyze in water to form either acidic or alkaline solutions which must be disposed off carefully. Acidic solutions can burn the skin completely due to a high affinity for water and corrode metals. Acidic soils destroy sometimes does not allow rapid growth of vegetation, kills soil living organisms. Most salts are used as fertilizers which when applied excessively, they cause ground water contamination, burn crops, increase air pollution and deplete minerals from the soil.

- **Inclusive education**

This unit involves a lot of research and calculations. To be able to understand it, there must be discussions, experiments and sharing of information among learners. You can organize your class and use different strategies to help all learners understand concepts very well.

- **Gender**

During group activities, try to form heterogeneous groups i.e. boys and girls or when learners start to present their findings, encourage both boys and girls to present and challenge each other.

- **Financial education:**

As this unit deals with many salts in modern life, you will draw learners' attention on the economic importance of making salts and common products made using that knowledge of salts.

- **Peace and values**

During group activities, you will encourage learners to work together, help each other where seems to be difficulty, and to respect each other's ideas.

11.4. Guidance on introductory activity

- Put your learners in groups of pairs or groups of 4 – 5 depending on the size of your class.
- Provide them with senior six chemistry students' books and guide them on the page where the unit and the introductory activity is.
- Ask them to discuss, provide them with worksheet to note their answers.
- Give them enough time like five minutes to analyze and discuss about the activity.
- Invite one representative from each group to present their findings. You may note some key points on the board and as you draw them towards the introductory content of this unit.

Expected answers to introductory activity

1. CuSO_4 , $\text{Pb}(\text{NO}_3)_2$ and CaCl_2 .
2. They dissociate into ions

11.5. List of lessons

#	Lesson title	Learning objectives	Periods
1	Definition of solubility and molar solubility	Define the term solubility product K_{sp} .	2
2	Unsaturated, saturated and super saturated solutions.	State and explain the factors that affect solubility of sparingly soluble salts.	1
3	Equations of the dissociation of sparingly soluble salts in water.	Write the equations of dissociation and K_{sp} expression for sparingly soluble salts.	1
4	Definition of solubility product K_{sp}	Explain the meaning of the term solubility product	1
5	Relationship between solubility and solubility product K_{sp}	Derive a relationship between solubility and solubility product	1
6	Calculations involving solubility product	Perform calculations involving solubility and solubility product	1

7	Definition and calculations of ionic product	Perform calculations about ionic product of salts	1
8	Predicting precipitation reactions using the ionic product and K_{sp}	Use the values of K_{sp} and Q_c to predict if a mixture of solutions will form a precipitate or not.	1
9	Separation of ions by fractional precipitation.	Explain how fractional precipitation is used in separation of ions.	1
10	Common ion effect and solubility	Explain common ion effect on the solubility of sparingly soluble salts.	1
11	pH and solubility	Explain the effect of pH on the solubility of sparingly soluble salt.	1
12	Complex ion formation and solubility	Relate the common ion effect to the solubility of sparingly soluble salt.	1
13	Applications of solubility product	Explain the applications of the solubility product and the common ion effect.	2
14	End unit assessment		2

Lesson 1: Definition of solubility and molar solubility

a. Prerequisites

Students will learn these definitions better if they have knowledge and understanding on the following units: Solutes, solvents and solution, solubility of salts and solubility rules, mole concept and concentration of solutions.

b. Teaching resources

You will use sodium chloride, barium sulphate, silver chloride, water, beakers, stirring rods.

c. Learning activities

Since students have already studied some of these definitions from the previous classes, you will not directly be involved in their discussion because they already know. Guide them through the following steps.

Methodological steps

- Put your learners in groups of pairs or groups of 4 – 5 depending on the size of your class.

- Guide learners on clearly defining a solute, solvent, solution, solubility and molar solubility.
- Let them discuss and give examples of where possible.
- You will keep checking on each group and guide them as they note down their summaries.
- End the lesson with a simple discussion about the dangers of acids salts to humans and the environment.
- Finally, give them the checking up activity to prove their understanding.

Expected answers to activity 11. 1

1. Solubility of a salt is given by the number of grams or number of moles of the salt (or solute) that will dissolve in 100 grams of water at a given temperature (g/100g of water or moles/100g of water).

Molar solubility refers to the number of moles of a solute that can be dissolved per liter of a solution (mol/l or mol/dm³).

2. In solubility equilibria the solubility product expression K_{sp} is only satisfied if the solution is saturated while other equilibria systems the equilibria constant is always satisfied.

Checking up 11.1

Expected answers to checking up 11. 1

1. The solubility of salt A and B increases with increased temperature.
2. (a) Letter C.
(b) Letter A.
(c) Letter B.

Lesson 2: Unsaturated, saturated and super saturated solutions

a. Prerequisites

Students will learn these definitions better if they have knowledge on solutes, solvents and solution, solubility of salts and solubility rules.

b. Teaching resources

Use a weighing scale, beakers, distilled water, sodium chloride or sugar crystals and a heat source.

c. Learning activities

Since this lesson is more of a practical than theory, give materials to use and guide them through the steps below.

Methodological steps

- Organize your class by putting students into group of 3 or 4 depending on the size of the class.
- Give each group a beaker of water, salt and a weighing scale and a stirring rod.
- Instruct a learner in each group to add a given amount of salt into water and dissolve.
- Another learner from each group can continue adding more salt and dissolving as they note down their observations.
- Provide learners with student's books and guide them on the page where they can find the introductory activity to this lesson and discuss the questions.
- Give them enough time to think and discuss about the possible answers relating them to simple experiment above.
- Comment on learners' responses and give them the summary of expected feedback based on their findings.

Expected answers to activity 11.2

1. The solution turns blue due to presence of Cu^{2+} ions.
2. The intensity of the blue color increases due to increased Cu^{2+} ions in solution.

Checking up

Expected answers to checking up 11.2

There is an increased concentration of ions.

Lesson 3: Equations of the dissociation of sparingly soluble salts in water

a. Prerequisites

Learners will understand it better if they have knowledge on balancing equations, chemical equilibrium and molar solubility.

b. Teaching resources

Use a computer, projector, internet and chalkboard.

c. Learning activities

Methodological steps

You will group learners into pairs (a boy and a girl where applicable), provide them with student's books and guide them on the page where to find the activity. Ask them to discuss, present their findings. You will iron out some issues and they take a summary of the facts.

Expected answers to activity 11.3

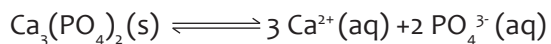
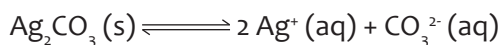
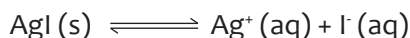
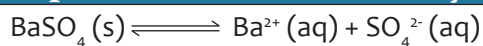

Checking up

Expected answers to checking up 11.3

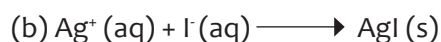
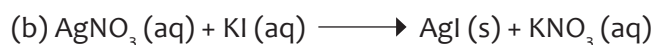
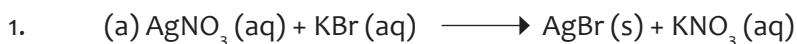

Lesson 4: Definition of solubility product K_{sp}

a. Prerequisites

Learners will understand it better if they have knowledge on balancing equations, chemical equilibrium and molar solubility.

b. Teaching resources

Use a computer, projector, internet and chalkboard.

c. Learning activities

For learning activities and methodological steps, refer to lesson 3 above.

Expected answers to activity 11.4

1. Solubility refers to how much of a substance can be dissolved in a given amount of a solution at a particular temperature, while solubility product is a numerical value of the solubility expression in a saturated solution.

2. The units for solubility product are mol dm^{-3}

Checking up 11.4

Expected answers to checking up 11.4

- (a) AgI $K_{sp} = [Ag^+][I^-]$
(b) $CaSO_4$ $K_{sp} = [Ca^{2+}][SO_4^{2-}]$
(c) Ag_2CO_3 $K_{sp} = [Ag^+]^2[CO_3^{2-}]$
(d) Li_3PO_4 $K_{sp} = [Li^+]^3[PO_4^{3-}]$

Lesson 5: Relationship between solubility and solubility product K_{sp}

a. Prerequisites

Learners will understand it better if they have knowledge on balancing equations, chemical equilibrium, molar solubility and solubility product.

b. Teaching resources

Use a computer, projector, internet and chalkboard.

c. Learning activities

For learning activities and methodological steps, refer to lesson 3 above.

Expected answers to activity 11.5

1. Solubility equilibrium refers to the kind of equilibrium that exists in saturated solutions of slightly soluble ionic salts.
2. This is the numerical value of the equilibrium constant for the equation that represents the substance dissolved in water.

Checking up 11.5

Expected answers to checking up 11.5

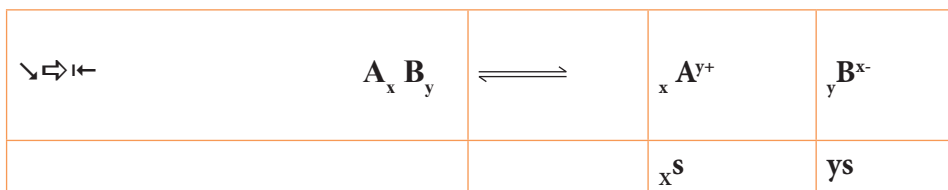

(b) $K_{sp} = (xs)^x (ys)^y$

$$s = \sqrt[x+y]{\frac{K_{sp}}{x^x y^y}}$$

$$(S)(2S)^2 = 1.8 \times 10^{-11}$$

$$(S)(4S^2) = 1.8 \times 10^{-11}$$

$$4S^3 = 1.8 \times 10^{-11}$$

$$\text{Molar solubility, } S = 1.65 \times 10^{-4}$$

$$(b) \text{ pOH} = 14 - \text{pH} = 14 - 11.22 = 2.78$$

$$[\text{OH}^-] = 10^{-2.78} = 1.66 \times 10^{-3} \text{ M}$$

Let x be mol dm^{-3} of $\text{Mg}(\text{OH})_2$ that dissolved (Molar solubility)

$$[\text{Mg}^{2+}][\text{OH}^-]^2 = 1.8 \times 10^{-11}$$

$$(x)(1.66 \times 10^{-3} + 2x)^2 = 1.8 \times 10^{-11}$$

Assuming that $2x$ is negligible compared to 1.66×10^{-3} .

$$(x)(1.66 \times 10^{-3})^2 = 1.8 \times 10^{-11}$$

$$(x)(2.7556 \times 10^{-6}) = 1.8 \times 10^{-11}$$

$$x = \frac{1.8 \times 10^{-11}}{2.7556 \times 10^{-6}}$$

$$x = 6.53 \times 10^{-6} \text{ M}$$

Lesson 7: Definition and calculations of ionic product

a. Prerequisites

Learners will understand if they have knowledge on identification of ions or qualitative analysis.

b. Teaching resources

Use a computer, projector, internet, chalkboard and worksheets

c. Learning activities

Before introducing this lesson, let learners first attempt the activity from the student's book.

As a facilitator, you are expected to guide learners through the following steps:

Methodological steps

- Organize your class by putting students into group of 3 - 4 depending on the size of the class.
- Provide learners with student's books and guide them on the page where they can find the activity and discuss the questions.
- Give them enough time to think, refer to notes and discuss about the possible answers.
- Check learners' responses and ideas, continue the discussions with a brief brainstorming on the content using students' book.
- Comment on learners' responses and give them the summary of expected feedback.

Expected answers to activity 11.7

1. The ion product of a salt is the product of the ion concentration in solution raised to the same power as in solubility expression.
2. Ion products is applicable to all types of solutions of any concentrations while K_{sp} is applicable to saturated solutions only

Checking up 11.7

Expected answers to checking up 11.7



$$K = \frac{[C]^2[D]}{[A][B]^3}$$

We need to find out how much A is consumed. This will allow us to determine how much C and D are produced and how much B is consumed

$$\text{Moles of A consumed} = \text{Initial mol} - \text{Final (equilibrium mol)} = 1.7 - 1.26 = 0.49 \text{ mol}$$

Now we find all the equilibrium concentrations

$$[A] = 1.26 \text{ mol.}$$

$$[B] = 2.75 - 3(0.49) = 1.28 \text{ M}$$

$$[C] = 0.65 + 2(0.49) = 1.63 \text{ M}$$

$$[D] = 0.49 \text{ M}$$

Lesson 8: Predicting precipitation reactions using the ionic product and K_{sp}

a. Prerequisites

Learners will understand if they have knowledge on solubility of salts and solubility rules, identification of ions or qualitative analysis.

b. Teaching resources

Use a computer, projector, internet, chalkboard and worksheets .

c. Learning activities

For methodological steps of the lesson, refer to lesson 7 above

Expected answers to activity 11.8

Homogeneous mixtures are in one phase, while heterogeneous mixtures are in more than one phase

Checking up

Expected answers to checking up 11.8

In every case you have got to consider the solubility of $X(OH)_2$

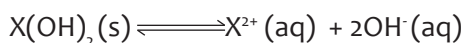

$$K_{sp} = [X^{2+}][OH^-]^2$$

With ammonia solution the $[OH^-] = 2.1 \times 10^{-3} \text{ mol dm}^{-3}$ because the original ammonia is diluted by the factor of 2 when the two solutions are mixed. $[X^{2+}]$ is also half of what it was originally for the same reason, $[X^{2+}] = 0.05 \text{ mol dm}^{-3}$. Multiplying these ion concentrations together in the same way as solubility product expression it gives.

$0.05 \times (2.1 \times 10^{-3})^2 = 2.2 \times 10^{-7} \text{ mol}^3 \text{ dm}^{-9}$. If this number is bigger than the solubility product you will get a precipitate as the excess ions are removed from the solution. If this number is smaller than the solubility product, equilibrium has not been reached and so no precipitate will form. Comparing the numbers given only magnesium hydroxide will form a precipitate.

With sodium hydroxide solution $[OH^-] = 0.50 \text{ mol dm}^{-3}$, because the original solution is diluted by a factor of 2, when the two solutions are mixed. Once again $[X^{2+}] = 0.05 \text{ mol dm}^{-3}$.

Multiplying these ion concentrations together in the same way as solubility product, expression gives $0.050 \times (0.50)^2 = 0.0125 \text{ mol}^3 \text{ dm}^{-9}$.

This number is bigger than all solubility product values given and so you will get a precipitate in each case.

Lesson 9: Separation of ions by fractional precipitation

a. Prerequisites

Learners will understand if they have knowledge on solubility of salts and solubility rules, identification of ions or qualitative analysis.

b. Teaching resources

Use a computer, projector, internet, chalkboard and worksheets

c. Learning activities

For methodological steps of the lesson, refer to lesson 7 above

Expected answers to activity 11.9

The solubility product K_{sp} is exceeded by the ionic product as a result of extra concentration of a common ion introduced.

Checking up

Expected answers to checking up 11.9

1. During water treatment to remove toxic materials by precipitation and filtration

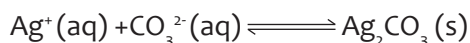
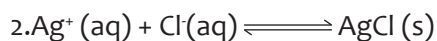

Lesson 10: Common ion effect and solubility

a. Prerequisites

Students will learn these definitions better if they have knowledge and understanding on the following units: Solutes and solvents, solubility of salts, solubility rules and solubility product, mole concept and concentration of solutions.

b. Teaching resources

Use iodine and potassium iodide, beakers and distilled water.

c. Learning activities

Remind your learners about solubility, molar solubility through question and answer approach, and guide them into the activity.

Methodological steps

- Put your learners in groups of pairs or groups of 4 – 5 depending on the size of your class.
- Guide learners on clearly defining solubility, molar solubility and common ion effect. Give them enough time to discuss.
- You will keep checking on each group and guide them as they note down their summaries.
- Finally, give them the checking up activity to prove their understanding.

Expected answers to activity 11.10

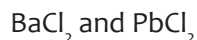

Checking up

Expected answers to checking up 11.10

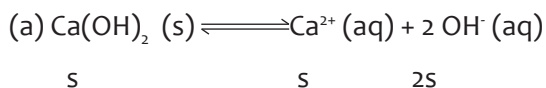

Where; $s = \text{mol dm}^{-3}$ of Ca(OH)_2 dissolved

$$[\text{Ca}^{2+}][\text{OH}^-]^2 = 5.5 \times 10^{-6}$$

$$(\text{S})(2\text{S})^2 = 5.5 \times 10^{-6}$$

$$s^3 = \frac{5.5 \times 10^{-6}}{4} = 1.375 \times 10^{-6}$$

Molar solubility, $s = 1.12 \times 10^{-2} \text{ M}$

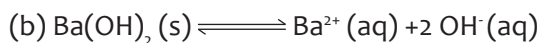

Since Ba(OH)_2 dissolves completely $[\text{OH}^-] = 2(0.77) = 1.54 \text{ M}$ from Ba(OH)_2

$$[\text{Ca}^{2+}][\text{OH}^-]^2 = 5.5 \times 10^{-6}$$

$$(\text{S})(1.54)^2 = 5.5 \times 10^{-6}$$

The logic behind the above statement is that you get $s \text{ mol dm}^{-3} \text{ Ca}^{2+}$ and $2s \text{ mol dm}^{-3} \text{ OH}^-$ from the Ca(OH)_2 plus another $1.54 \text{ mol dm}^{-3} \text{ OH}^-$ from Ba(OH)_2 , Neglect $2s$ compared to 1.54 .

$$(\text{s})(1.54)^2 = 5.5 \times 10^{-6}$$

$$(\text{s})(2.3716) = 5.5 \times 10^{-6}$$

$$s = \frac{5.5 \times 10^{-6}}{2.3716}$$

$$s = 2.32 \times 10^{-6} \text{ M}$$

Lesson 11: pH and solubility

a. Prerequisites

Students will learn these definitions better if they have knowledge and understanding on pH of acidic and alkaline solutions.

b. Teaching resources

Use worksheets, flip charts, chalkboard, beaker, water, litmus paper, acidic and alkaline substances and the pH meter

c. Learning activities

Methodological steps

- First discuss with learners about checking up activity of the above lesson. Give them facts and motivate them to make more research.

- Let learners discuss the activity using their prior knowledge and write their ideas on worksheets.
- Have sample groups to present their ideas/findings to the class.
- Check learners' responses and give them a summary of expected feedback
- Involving all learners in the discussion of concepts. Comment on the students' responses.
- Direct the learners to the checking up activity at the end of the lesson or give it to them as homework.

Expected answers to activity 11.11

1. pH is a measure of the hydrogen ion concentration of a solution.

pH is defined as negative logarithm to base ten of molar concentration of hydrogen ions in solution.

Mathematically, $\text{pH} = -\log_{10}[\text{H}^+]$ or $\text{pH} = -\log_{10}[\text{H}_3\text{O}^+]$

2. Sparingly soluble salts produce ions which combine with hydrogen ions to form weak

or poorly dissociated acid molecules. This reduces the concentration of hydrogen ions

in the solution and affects the solubility of the solutes.

Checking up

Expected answers to checking up 11.11

1. (a) Addition of concentrated ammonia solution increases the solubility of silver oxalate. This is because silver ions react with ammonia molecules to form a soluble complex known as silver (I)diamine.

(b) Addition of oxalate ions in solution decreases the solubility of silver oxalate because sodium oxalate contains oxalate ions that are common to oxalate ions in silver oxalate thus the excess oxalate ions added would combine with silver ions in the solution to precipitate silver oxalate which decreases its solubility.

2. (a) $\text{Sr}(\text{OH})_2 (\text{s}) \rightleftharpoons \text{Sr}^{2+} (\text{aq}) + 2 \text{OH}^- (\text{aq})$

(b) $K_{\text{sp}} = [\text{Sr}^{2+}] [\text{OH}^-]^2$

(c) (i) Solubility of strontium hydroxide decreases.

(ii) Sodium hydroxide provides a high concentration of hydroxide ions which react with strontium ions to precipitate more strontium hydroxide thus decreasing its solubility.

Lesson 12: Complex ion formation and solubility

a. Prerequisites

Students will learn complex ion formation better if they have knowledge and understanding on transition metal and how they form complexes and solubility of salts.

b. Teaching resources

Use copper (II) sulphate and aqueous ammonia, potassium iodide and iodine, water and beakers.

c. Learning activities

Refer to the above lesson for methodological steps.

Expected answers to activity 11.12

- (a) A complex ion is an ion formed when a transition metal ion is surrounded by other molecules or ions which use lone pairs of electrons to form dative covalent bonds with the d-block metal.
(b) Ligands are negative ions or molecules with dipoles or lone pairs of electrons or negative charges which form dative covalent bonds with the central metal atom or ion.
(c) Coordination number refers to the number of ligands directly bonded or surrounding the central metal atom or ion.
(d) Hydrated cations are those cations surrounded by water molecules as ligands.
(e) Lewis base is an electron pair donor and a proton acceptor.
- The order of ligand strength as Lewis bases is $\text{CN}^- > \text{NH}_3 > \text{Cl}^- > \text{H}_2\text{O}$

Checking up

Expected answers to checking up 11.12

- Availability of empty or vacant orbitals Ionic charge of the cation Ionic radius of the cation
- Basing on the size of the ion, the shape of the complex ion can change accordingly, for example chloride ion is bigger and many metal ions can accommodate fewer of them.

Lesson 13: Applications of solubility product

a. Prerequisites

Students will understand the applications if they have knowledge on solubility of salts, ionic product and solubility product.

b. Teaching resources

Use worksheets, flip charts, chalkboard, computer and internet.

c. Learning activities

Having studied solubility and solubility product, their applications are so simple from the previous discussions. As a facilitator, you are expected to guide learners to learn through these steps.

Methodological steps

- Organize your class by putting students into pairs, a boy and a girl where applicable.
- Let them discuss the activity and the applications of solubility product using reference books or internet to find answers where they find challenges.
- Choose randomly a representatives from each groups to present their findings.
- Allow some other students to comment about the findings presented by their colleagues.
- Through different small oral questions, help the students to make the conclusions and summaries themselves.

Expected answers to activity 11.13

Solubility products can be used in the following areas;

- (a) Soap making
- (b) Separation of mixtures
- (c) Qualitative analysis
- (d) Volumetric analysis

Checking up 11.13

Expected answers to checking up 11.13

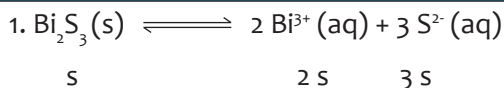

Where; $s = \text{Bi}_2\text{S}_3 \text{ mol dm}^{-3}$ that dissolved

$$[\text{Bi}^{3+}]^2 [\text{S}^{2-}]^3 = 1 \times 10^{-97}$$

$$(2s)^2 (3s)^3 = 1 \times 10^{-97}$$

$$(4s^2) (27s^3) = 1 \times 10^{-97}$$

$$108s^5 = 1 \times 10^{-97}$$

$$s^5 = \frac{1 \times 10^{-97}}{108} = 9.259 \times 10^{-100}$$

$$s = 1.56 \times 10^{-20} \text{ M}$$



$$[\text{Bi}^{3+}]^2 [\text{S}^{2-}]^3 = 1 \times 10^{-97}$$

$$(2s)^2 (0.50 + 3s)^3 = 1 \times 10^{-97}$$

Assume $3s$ is negligible compared to 0.50 ;

$$(2s)^2 (0.50)^3 = 1 \times 10^{-97}$$

$$s^2 = \frac{1 \times 10^{-97}}{(4)(0.125)} = 2 \times 10^{-97}$$

$$s = 4.47 \times 10^{-49}$$

$$\text{Bi}_2\text{S}_3 = 514.26 \text{ g/mol}$$

Therefore, grams of Bi_2S_3 that would dissolve in one dm^3 of solution is,

$$(4.47 \times 10^{-49} \text{ mol dm}^{-3}) (514.26 \text{ g/mol})$$

11.6. Summary of the unit

- Solubility is the amount of solid/solute either in moles or grams that dissolves in a given amount of the solvent at equilibrium producing ions in solution. Usually, it is defined as number of grams or number of moles of the solid/solute that will dissolve in 100g of water at a given temperature. It is fundamentally expressed in molar (mol l^{-1} of solution) or molal (mol kg^{-1} of water).
- Molar solubility can be expressed as the number of moles of a solute that can be dissolved per liter of solution before the solution becomes saturated.
- A saturated solution is one which contains the maximum amount of dissolved solid at a particular temperature. If the quantity of a substance in a solution is less than that required to get the equilibrium with the solid, the solution is said to be “unsaturated”. A super saturated solution contains more solute than a saturated solution.
- A sparingly soluble solute is one which slightly dissolves in a given solvent. It partly dissociates into component ions. The equation for this solubility is reversible.
- The solubility product is the equilibrium constant expressed in terms of concentrations of the ions produced from a sparingly soluble solid in contact with a saturated solution. The equilibrium constant for the system is given the symbol K_{sp} . The concentrations of various ions are simply raised to the power of the stoichiometric number in the equation.
- Solubility products are only constant at a particular temperature which is usually 298K.
- The ionic product (Q) of salt is the product of the concentrations of the ions in solution raised to the same power as in solubility product expression. Ionic product describes concentrations that are not necessarily equilibrium concentrations.
- K_{sp} is applicable to saturated solutions only, whereas ion product is applicable to all types of solutions of any concentration.
- Homogenous mixtures appear in one phase while heterogeneous mixtures are

in more than one phase. Sparingly soluble salts form heterogeneous mixtures involving formation of precipitates. Homogeneous mixtures do not form precipitates.

- Ions can be separated from each other basing on the solubility of their salts in water. This is done by using a reagent that forms a precipitate with one or a few of the ions in solution (fractional precipitation)
- Common ion effect is the precipitation of a sparingly soluble salt from its saturation by adding a soluble compound containing one of the ions contained by the sparingly soluble salt.

11.7. Additional information for teachers

A sparingly soluble salt is one which dissolves up to a certain point beyond which no more of it dissolves. At this point, the equilibrium is established between the unionized solid and the ions produced. For example;

$\text{MX (s)} \rightleftharpoons \text{M}^+ \text{(aq)} + \text{X}^- \text{(aq)}$; this is the solubility equation.

$$K = \frac{[\text{M}^+][\text{X}^-]}{[\text{MX}]}$$

Because the solid is too much, its solubility is taken to be a constant.

$K_{\text{sp}} = [\text{M}^+][\text{X}^-]$; this is the expression of solubility product.

The idea of solubility product, K_{sp} can be used to show conditions under which an electrolyte will dissolve to form a solution or precipitate from the solution.

When the ionic product is equal to the solubility product, the solution is saturated and will not dissolve any more solutes.

If the ionic product tend to exceed the solubility product, the solution is super saturated i.e. it contains excess undissolved solutes but this cannot take place because solubility product is a constant at constant temperature, instead the excess solid will precipitate out of the solution

Ostwald's Dilution Law applies to sparingly soluble salts binary weak electrolytes.

When a sparingly soluble salt is dissolved in water, it partially ionizes so that equilibrium is established between the ions and the undissolved molecules.

For example;

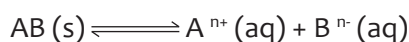

If α is the degree of ionization of this electrolyte and 'C' is the concentration of the electrolyte in mol dm^{-3} , then, the concentrations at equilibrium becomes;



$$C(1 - \alpha) \quad c\alpha \quad C\alpha$$

Applying the equilibrium law to the concentrations at equilibrium,

$$K = \frac{(c\alpha)(c\alpha)}{c - c\alpha} = \frac{c^2\alpha^2}{c(1-\alpha)} = \frac{c\alpha^2}{1-\alpha}$$

For a weak acid, α is too small such that $1 - \alpha \approx 1$

Therefore, $K = C\alpha^2$

$$\alpha^2 = \frac{K}{C}$$

$$a = \sqrt{\frac{K}{C}}$$

Ostwald's dilution law states that "for a weak binary electrolyte, the degree of ionization is inversely proportional to the square root of the concentration or directly proportional to the reciprocal of the square root of concentration"

Ostwald's dilution law does not apply to strong electrolytes as they are completely ionized.

Under what conditions will ionic product tend to exceed solubility product such that precipitation of salts takes place

(i) By evaporation: Evaporation tend to increase the concentration of ions.

(ii) By addition of a common ion. This also increases the concentration of ions.

A good example of common ion effect is the salting out of soap.

Here, concentrated solution of sodium chloride (brine) is added to a saturated solution of soap ($C_{17}H_{35}COONa$), and considering soap in solution.

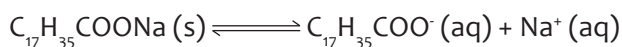

When sodium chloride is added, the concentration of sodium ions increases and becomes excess. The excess react with the $C_{17}H_{35}COO^-$ to precipitate out soap to upper layers ($C_{17}H_{35}COONa$) so as to keep K_{sp} constant.

Addition of a solution of a soluble salt which does not contain a common ion increases the solubility for example, addition of a solution of silver nitrate to a saturated solution of lead (II) chloride. Silver ions from silver nitrate react with chloride ions from lead (II) chloride at equilibrium to form an insoluble silver chloride. This reaction reduces the concentration of chloride ions in the equilibrium and in order to restore K_{sp} , more $PbCl_2$ ionizes or dissolves.

This explains why;

- Barium sulphate dissolves more rapidly in lead (II) nitrate than in water.
- Lead (II) iodide is more soluble in silver nitrate than in water.

11.8. End unit assessment

Expected answers to end unit assessment

1. The answer is NO. This is because they do not have the same solubility product expressions.
2. (i) $K_{sp} = [Hg_2^{2+}][Cl^-]^2$
(ii) $K_{sp} = [Sr^{2+}]^3[AsO_4^{3-}]^2$

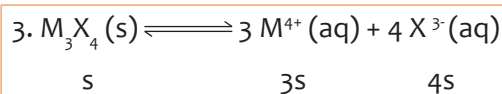

Where, s is solubility of $\text{M}_3\text{X}_4 (\text{s})$ mol/dm³

$$K_{sp} = [\text{M}_4^{+}]^3 [\text{X}^{3-}]^4 = 8.2 \times 10^{-24}$$

$$(3s)^3 (4s)^4 = 8.2 \times 10^{-24}$$

$$(27s^3)(256s^4) = 8.2 \times 10^{-24}$$

$$6912 s^7 = 8.2 \times 10^{-24}$$

$$S = 1.42 \times 10^{-4}$$

4. The common ion effect refers to the shifting of equilibrium system caused by a common ion in the system from a source other than the system itself.

Lechatelier 's principle predicts this effect.

Example; if you were to add some Cl⁻ ions or Ag⁺ ion to a saturated solution of AgCl.

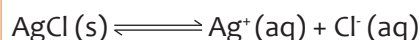

Adding a common ion to the system increases the concentration of the Cl⁻ and silver ions the system will shift to the left to undo this stress.

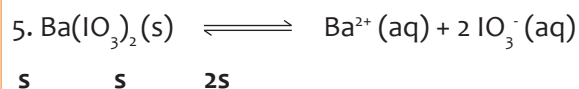

Where; s = mol of $\text{Ba}(\text{IO}_3)_2$ that dissolved.

$$[\text{Ba}^{2+}] [\text{IO}_3^-]^2 = 1.5 \times 10^{-9}$$

$$(S) (2S)^2 = 1.5 \times 10^{-9}$$

$$(S) (4S^2) = 1.5 \times 10^{-9}$$

$$4S^3 = 1.5 \times 10^{-9} \quad S = 7.2 \times 10^{-4} \text{ M}$$

Molar solubility = 7.2×10^{-4} mol/dm³

11.9. Additional activities

11.9.1. Remedial activity

Questions

- 1.(a) Explain what is meant by common ion effect.
 - (b)(i) State how the solubility product of a sparingly soluble salt may be determined.
 - (ii) State how the solubility of a soluble salt can be affected by adding a common ion
 - (c) State one application of solubility product

2. The solubility of calcium phosphate $\text{Ca}_3(\text{PO}_4)_2$ is 0.0011g per 100g of water at 25°C.

Calculate the solubility product of calcium phosphate. (Ca=40, P=31, O=16)

What would be the effect on the solubility of calcium phosphate when a solution of sodium phosphate is added to a saturated solution of calcium phosphate?

3.) What is meant by the term acid according to the Bronsted – Lawry theory of acids and bases?

b) Identify two substances acting as acids in the following reaction:

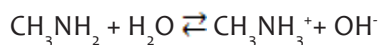

(c) Write an expression for the solubility product (K_{sp}) of calcium hydroxide.

(d) A 20.0cm³ sample of saturated, aqueous calcium hydroxide required 18.2 cm³ of 0.050 mol dm⁻³ hydrochloric acid for neutralization. Calculate:

i) the concentration of OH⁻ in the saturated solution.

ii) A value for the solubility product of calcium hydroxide, stating the units.

(e) Explain why calcium hydroxide is more soluble in water than potassium hydroxide

Answers

1. (a) Common ion effect is the precipitation of a sparingly soluble ionic compound from a saturated solution, by addition of another soluble compound containing a similar ion.

(b)(i) - By titration or volumetric analysis

- By conductivity measurements

- By ion exchange

(ii) Addition of a common ion reduces the solubility of a sparingly soluble salt.

(c) - Purification of common salt or sodium chloride

- Purification or salting out of soap

- Predicting precipitation of salts in qualitative analysis.

- Selective separation of sulphides

2. (a) $\text{Ca}_3(\text{PO}_4)_2 \rightleftharpoons 3\text{Ca}^{2+} + 2\text{PO}_4^{3-}$, let the solubility of Ca^{2+} be x:



$$K_{sp} = [\text{Ca}^{2+}]^3[\text{PO}_4^{3-}]^2$$

$$= (3x)^3(2x)^2 = 108 x^5$$

Solubility of $\text{Ca}_3(\text{PO}_4)_2$ in g/l

$$1 \text{ g} = 1 \text{ cm}^3 = 1 \text{ ml}$$

$$1000 \text{ cm}^3 \rightarrow \frac{0.0011 \times 1000}{100} = 0.011 \text{ g/l}$$

$$\text{Solubility of } \text{Ca}_3(\text{PO}_4)_2 \text{ in moles dm}^{-3} = \frac{\text{concentration in g/l}}{\text{Rmm in g/l}}$$

$$\text{RMM of } \text{Ca}_3(\text{PO}_4)_2 = 40 \times 3 + (31+16) \times 2 = 310$$

$$\text{Hence, solubility of } \text{Ca}_3(\text{PO}_4)_2 \text{ in moles dm}^{-3} = \frac{0.011}{310} = 3.55 \times 10^{-5} \text{ mol dm}^{-3}$$

$$\text{Solubility of } \text{Ca}^{2+} \text{ which is } x \text{ is } 3.55 \times 10^{-5} \text{ mol dm}^{-3}$$

$$K_{sp} = 108 x^5 = 108 (3.55 \times 10^{-5})^5 = 6.08 \times 10^{-21} \text{ mol}^5 \text{ dm}^{-15}$$

(b) The solubility of $\text{Ca}_3(\text{PO}_4)_2$ decreases because of common ion effect. Addition of sodium phosphate increases the concentration of phosphate ions in equilibrium. So to restore K_{sp} , the excess phosphate ions from Na_3PO_4 react with Ca^{2+} .

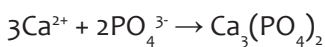

This decreases the solubility of calcium phosphate.

3. (a) Acid is proton donor according to Bronsted-Lowry theory of acids and bases.

(b) H_2O and CH_3NH_3^+ are acting as acids.

$$(c) K_{sp} = [\text{Ca}^{2+}][\text{OH}^-]^2$$

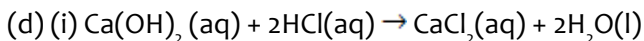

1000 cm^3 contain 0.050 moles of HCl

$$18.2 \text{ cm}^3 \text{ contain } \frac{0.050 \times 18.2}{1000} = 0.00091 \text{ moles of HCl}$$

2 moles of HCl \rightarrow 1 mole of $\text{Ca}(\text{OH})_2$

$$0.00091 \text{ moles of HCl} \rightarrow \frac{1 \times 0.00091}{2} \text{ of } \text{Ca}(\text{OH})_2 = 0.000455 \text{ mol of } \text{Ca}(\text{OH})_2$$

20 cm^3 contain 0.000455 mol of $\text{Ca}(\text{OH})_2$

$$1000 \text{ cm}^3 \text{ contain } \frac{0.000455 \times 1000}{20.0} = 0.02275 \text{ M of } \text{Ca}(\text{OH})_2$$

But one mole of $\text{Ca}(\text{OH})_2$ is produced by 2 moles of OH^-

Thus concentration of $\text{OH}^- = 2 \times 0.02275 \text{ mol dm}^{-3} = 0.0455 \text{ mol dm}^{-3}$

$$(ii) [\text{Ca}^{2+}] = 0.02 \text{ mol dm}^{-3}$$

$$[\text{OH}^-] = 0.0455 \text{ mol dm}^{-3}$$

$$K_{sp} = [\text{Ca}^{2+}][\text{OH}^-]^2$$

$$K_{sp} = (0.02275 \text{ mol dm}^{-3})(0.0455 \text{ mol dm}^{-3})^2 = 4.7 \times 10^{-5} \text{ mol}^3 \text{ dm}^{-9}$$

(e) Calcium hydroxide is less soluble in potassium hydroxide due to the common ion effect of OH^- which reduces the solubility of calcium hydroxide.

11.9.2. Consolidation activities

Questions

1. Explain the following observations:

- (a) When solution of sodium sulphate is added to a saturated solution of lead (II) sulphate, a precipitate of lead (II) sulphate was formed.
- (b) Iodine is much more soluble in potassium iodide than in water.

2. Barium sulphate is sparingly soluble in water.

- (a) (i) Write an equation for the solubility of barium sulphate in water.
(ii) Write the expression for the solubility product of barium sulphate.
- (b) A saturated solution of barium sulphate contains 1.1×10^{-5} moles per litre of the salt. Calculate the solubility product of barium sulphate
- (c) Calculate the solubility of barium sulphate in a litre of 0.1M barium solution in mol/l.

Answers

1. (a) Addition of sodium sulphate increases the concentration of sulphate ions in solution. Therefore, the excess sulphate ions combine with lead ions to form insoluble lead (II) sulphate which precipitates.

(b) The molecules of iodine are non-polar whereas those of water are polar. Therefore, since the two interactions are completely different, iodine will be insoluble in water.

However, iodine is more soluble in potassium iodide due to formation of a soluble complex, potassium triiodide.

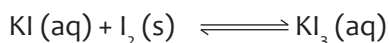

Formation of this soluble complex offsets the equilibrium and this causes iodine to dissolve so as to re-establish the position of the equilibrium.

2. (a)(i) $\text{BaSO}_4 (\text{s}) + \text{aq.} \rightleftharpoons \text{Ba}^{2+} (\text{aq}) + \text{SO}_4^{2-} (\text{aq})$



(b) Solubility, $S = 1.1 \times 10^{-5} \text{ mol dm}^{-3}$

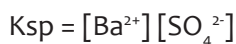

$$K_{\text{sp}} = (1.1 \times 10^{-5})(1.1 \times 10^{-5})$$

$$K_{\text{sp}} = 1.21 \times 10^{-10} \text{ mol}^2 \text{ dm}^{-6}$$

(c) Let the solubility of barium sulphate in 0.1M barium solution be S'

$[Ba^{2+}] = (0.1 + S') = 0.1$, since S' is very small.

$[SO_4^{2-}] = S'$

$K_{sp} = [Ba^{2+}][SO_4^{2-}]$

$1.21 \times 10^{-10} = 0.1 \times S'$

$S' = \left(\frac{1.21 \times 10^{-10}}{0.1} \right)$

$S' = 1.21 \times 10^{-9} \text{ mol dm}^{-3}$

11.9.3. Extended activities

Questions

1. (a)(i) Describe an experiment which can be carried out to determine the solubility product of calcium iodate, $Ca(IO_3)_2$.

(ii) The solubility product of calcium iodate is $1.69 \times 10^{-9} \text{ mol/l}$ at 25°C . Calculate the concentration of iodide ions in a solution of calcium iodate at 25°C .

(iii) State three factors that can affect the solubility product.

(b) (i) 0.1 mole of calcium nitrate was added to a litre of saturated solution of calcium iodate and the mixture stirred. Calculate the mass of calcium iodate which was

precipitated. State any assumptions you will make.

(ii) Triphosphate ions form a soluble complex with calcium ions. State what would happen when triphosphate ions are added to a saturated solution of calcium iodate and give a reason for your answer.

2. The solubility product K_{sp} , of zinc hydroxide is 4.5×10^{-17} at 25°C

(a) Write an expression for the solubility product of zinc hydroxide.

(b) Determine the concentration in moles per litre of zinc and hydroxide ions in a

saturated solution of zinc hydroxide at 25°C .

(c) State how the solubility of zinc hydroxide would change if its saturated solution is treated separately with:

(i) Aqueous zinc sulphate

(ii) Ammonia

(d) Briefly explain your answers in (c).

Answers

1. (a)(i) Determination of solubility product of calcium iodate in water

- A known volume of distilled water is placed in a bottle and a large excess of calcium iodate is added.
- The bottle is then stoppered and left to stand for several hours, while shaking occasionally so as to attain equilibrium.
- After equilibrium has been attained, aliquots (known volume) of the clear saturated solution are pipetted into a conical flask containing potassium iodide with sulphuric acid.
- $\text{IO}_3^- (\text{aq}) + 5\text{I}^- (\text{aq}) + 6\text{H}^+ (\text{aq}) \longrightarrow 3\text{I}_2 (\text{aq}) + 3\text{H}_2\text{O} (\text{l})$
- The iodine liberated is then titrated with a standard thiosulphate solution using starch indicator.
- $2\text{S}_2\text{O}_3^{2-} (\text{aq}) + \text{I}_2 (\text{aq}) \longrightarrow \text{S}_4\text{O}_6^{2-} (\text{aq}) + 2\text{I}^- (\text{aq})$
- Titrate until when the solution turns blue (end point)
- Repeat the titration and note the average volume of the thiosulphate solution used.
- The concentration of the iodate ions is calculated from the average volume of the thiosulphate using the equations above.
- Since 1 mole of calcium iodate dissociates to give 1 mole of calcium ions for every 2 moles of iodate ions, then $[\text{Ca}^{2+}] = \text{half of } [\text{IO}_3^-]$,
- $K_{\text{sp}} = [\text{Ca}^{2+}] [\text{IO}_3^-]^2$

(ii) The solubility, s of a sparingly soluble salt, $\text{Ca}(\text{IO}_3)_2$ is related to its ionic concentration.

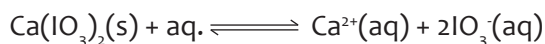

If the solubility or concentration of salt is s and K_{sp} is $1.69 \times 10^{-9} \text{ mol/l}$

$$K_{\text{sp}} = [\text{Ca}^{2+}] [\text{IO}_3^-]^2$$

$$1.69 \times 10^{-9} = s \cdot (2s)^2$$

$$s = \sqrt[3]{\frac{1.69 \times 10^{-9}}{4}}$$

$$s = 7.504 \times 10^{-4} \text{ mol/l}$$

- (iii)
- Change in temperature
 - Addition of a common ion salt
 - Complex ion formation

(b)(i) Calcium nitrate is a strong electrolyte which fully ionizes, thus the concentration of calcium ions is assumed to be equal to that of calcium nitrate which is 0.1M.

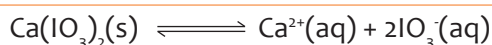

Let the solubility in 0.1M solution calcium nitrate be S'

$$[\text{Ca}^{2+}] = (S' + 0.1)$$

$$[\text{IO}_3^-] = 2S'$$

$$K_{sp} = [\text{Ca}^{2+}][\text{IO}_3^-]^2$$

$$K_{sp} = (S' + 0.1) \cdot (2S')^2$$

But $(S' + 0.1) = 0.1$ since $S' \ll \ll \ll \ll 0.1$, i.e. solubility of calcium iodate is very small.

$$(1.69 \times 10^{-9}) = (0.1) \cdot (2S')^2$$

$$S' = 6.5 \times 10^{-5} \text{ mol/l}$$

$$\text{Moles undissolved} = S - S' = (7.504 \times 10^{-4}) - (6.5 \times 10^{-5}) = 6.854 \times 10^{-4} \text{ moles/litre}$$

$$\text{Molar mass of } \text{Ca}(\text{IO}_3)_2 = 390 \text{ g/mol}$$

$$\text{Mass or amount of calcium iodate precipitated} = (6.854 \times 10^{-4}) \times 390 = 0.267 \text{ g}$$

(ii) Solubility of calcium iodate increases

Reason:

Formation of a complex reduces the concentration of calcium ions in the solution, and this disturbs the equilibrium so that more calcium iodate dissolves to maintain the equilibrium constant. Or Formation of a complex reduces the concentration of calcium ions to such a low level, that the solubility product of calcium iodate is no longer exceeded, hence a solution results.

2. (a) $K_{sp} = [\text{Zn}^{2+}][\text{OH}^-]^2$

(b) Let the concentration in mol/l of Zn^{2+} be X and that of OH^- be $2X$

$$K_{sp} = [\text{Zn}^{2+}][\text{OH}^-]^2$$

$$4.5 \times 10^{-17} = X \cdot (2X)^2$$

$$4.5 \times 10^{-17} = 4X^3$$

$$X = \sqrt[3]{\frac{4.5 \times 10^{-17}}{4}}$$

$$X = 2.24 \times 10^{-6}$$

$$[\text{Zn}^{2+}] = 2.24 \times 10^{-6} \text{ mol/l}$$

$$[\text{OH}^-] = 2(2.24 \times 10^{-6}) = 4.8 \times 10^{-6} \text{ mol/l}$$

(c)(i) Solubility of zinc hydroxide decreases.

(ii) Solubility of zinc hydroxide increases.

(d) Addition of zinc sulphate increases the concentration of the zinc ions in solution.

This consequently causes zinc hydroxide to precipitate due to common ion effect hence decreasing the solubility.

Addition of ammonia causes formation of a complex with zinc ions. This decreases the concentration of zinc ions in the solution, so that more zinc hydroxide dissolves to restore the equilibrium.

UNIT 12: ELECTROCHEMICAL CELL AND APPLICATIONS

12

12.1. Key unit competency

To be able to explain the working and industrial applications of electrochemical and electrolytic cells

12.2. Prerequisite

Students will learn better electrochemical cells and its applications if they have good understanding on the following:

- **Reduction and oxidation reactions** (Senior 4, unit 17) precisely explanation of oxidizing and reducing agents; oxidation and reduction, reduction and oxidation half reactions balancing and reactivity series of metals;
- **Conductivity of solutions** (Senior 5, unit 12) mainly types of conductors, electrolytes, conductivity of electrolytes, mobility of ions, etc;
- **Electrolysis** (Senior 5, unit 13) especially laws of electrolysis, decomposition voltage of electrolytes, electroplating, anodizing, etc.

12.3. Cross-cutting issues to be addressed

- **Financial Education**

Electrochemical cells find many applications in many activities. They are used every day in electronic devices (laptop computers, clocks, radios, remote controls, calculators, vehicles, etc) to produce electrical energy needed. It is in this way that the student who is studying this unit be aware that he can make money from these cells and/or batteries as they are needed by a huge number of users. Another issue to address is that these cells have advantages and disadvantages, meaning that the study must lead to the knowledge of being able to choose the better (with few disadvantages) like those which last long, rechargeable and easily affordable.

- **Standardisation culture**

Every student who can learn electrochemical cells and its applications must be informed the way to use the standard ones. This is because the cells poorly used may have many harmful effects, and for human beings and for the environment in general. For example, some components of the electrochemical cells contain poisonous chemicals like mercury (Hg), lead (Pb), etc; and several which are disposable are the main environmental pollutants, so use the ones which are not expiring soon or not expired and this culture must be developed mainly basically from the school.

12.4. Guidance on the introductory activity

The main application of electrochemical cells is the production the electrical energy. To introduce this unit, remember to use the activity which shows the working of an electrochemical cell and shows its main use (application) at the same time. Here two activities are proposed to you the teacher and for students.

The following is a guidance of how you can use one or all these activities to help your learners enter in the unit with open mindset about the methods of extraction of different metals and being motivated.

Guidance to the INTRODUCTORY ACTIVITY

Activity 1

This activity must be done in the laboratory, prepare the materials and chemicals needed before starting this unit.

- Put your students in groups of 4-6 (depending on the size of your class).
- Provide them with the introductory activity (you can use the chalkboard, books, and worksheets or even use the projector).
- Give them time between 10 and 15 minutes to read, analyze, perform the experiment, interpret, discuss and answer questions about the activity.
- Ask 3 groups to present their findings.
- Allow some students to comment about the findings of their colleagues presented.
- Take this time to use some questions in order to draw the conclusion which is in line with the objectives of the unit (using the answers being provided by student).

Proposed answers

1. The bulb gives light
2. Lighting
3. When Mg ribbon and Cu foil are placed in the solution of sulphuric acid (electrolyte), they are dissolved; the (redox) reactions occur at/for every metal placed in the solution. The electrons are transferred and then produces electricity (form these reactions).

Activity 2

This is another activity which also shows clearly the working and the main application of an electrochemical cell. It requires having the internet access to download the video on this link: http://www.youtube.com/watch?v=C26pH8kC_Wk

It is better to download it before and use a videoplayer while teaching. Once having the video and the videoplayer (here you may use the computer and the projector), you can now use this activity to introduce your unit.

- Allow the students to watch this small video carefully and attentively because they have questions required to be answered using their observations.
- Put your students in groups of four (4)
- Give them the *discussion questions* about this video (you can also use the chalkboard, books, and worksheets or even use the projector)
- Give them time between 15 and 20 minutes to answer discussion questions provided.
- Randomly, choose four (4) groups to present their findings.
- Allow some students to comment about the findings of their colleagues presented.
- Take this time to draw the conclusion (by asking some short questions about the observation and the answers provided to the discussion questions) which is in line with the objectives of the unit.

Proposed answers to discussion questions

1. A zinc bar placed into a zinc sulphate
2. A copper bar placed into a copper sulphate solution
3. NaCl salt bridge
4. To prevent the two electrolytes from mixing and allow ions to migrate
5. From zinc electrode to copper electrode
6. Zinc is more active metal than carbon.
7. Zinc metal
8. Zinc metal oxidized and form zinc ion and release two electrons.
9. Disappearance of blue colour
10. Copper metal
11. Copper ion in the solution gains two electrons and reduced to copper metal and deposited on the cathode.
12. Sodium ions from salt bridge migrate into copper sulphate solution and neutralized the excessive SO_4^{2-} ions.
13. Chloride ions from salt bridge migrate into zinc sulphate solution and neutralized the excessive Zn^{2+} ions.
14. Identify the important characteristics of a cell.
15. Suggest any use of this electrochemical cell.

Justification of this introductory activity:

This activity started with the animation of galvanic cell, where this video only takes short time (2.08 minutes) but it is good enough for the students to learn the abstract concept of galvanic cell. Besides that, the video can make them enjoy more to learn difficult things and helps them to solve the problem of the imagination-skill in galvanic cell. Therefore, the ability to practice new concepts in a risk-free environment improves learners' skills and abilities. Furthermore, it also improves your skills and ability because you will be able to change your way of teaching to be better. Hopefully from this activity, students will be able to understand the concept of galvanic cell in a dynamic blend of macroscopic, submicroscopic, and symbolic elements.

12.5. List of lessons/subheadings

Nº	Lesson title	Learning objectives	Nº of periods
1	Introductory activity & Definition of electrochemical cell	Define the term electrochemical cell.	2
2	Description of electrochemical cells.	<ul style="list-style-type: none">• Construct a simple galvanic cell.• Describe the standard hydrogen electrode.• Record the results of a measurement accurately using a voltmeter.• Explain the working of galvanic cells using the fully labelled diagram.• Calculate standard cell potentials from standard electrode potentials of two half cells.	7

3	Prediction of spontaneity of redox reactions.	<ul style="list-style-type: none"> Use the e.m.f. of the galvanic cell to predict if the cell will generate current or not. Use standard electrode potentials of cells to determine the direction of electron flow and feasibility of a reaction. 	2
4	Explanation of the effect of concentration on e.m.f. of the cell (using Nernst equation)	<ul style="list-style-type: none"> Predict how the value of an electrode potential varies with concentration using Le Chatelier Principle. Develop a culture of team work, sense of responsibility in group activities and experiments. 	4
5	Explanation of corrosion and its effects on metallic objects.	Appreciate contributions of electrochemistry to the social and economic development of the society.	2
6	Applications of electrochemical cell	<ul style="list-style-type: none"> Describe industrial applications of electrochemical cells. Apply the principles of redox processes to energy storage devices. 	4
7	Comparison between electrochemical cell and electrolytic cell.	<p>Properly use electrolytic cell to carry out electroplating of graphite by copper.</p> <p>Compare electrochemical cell with electrolytic cell.</p>	2
ASSESSMENT			2

Lesson 1: Definition of electrochemical cell

a. Prerequisites/Revision/Introduction

For ease studying of the what the electrochemical cell is, it requires knowledge about the oxidation and reduction reactions that must be studied in Senior 4, unit 17; electrolytic cell as studied in electrolysis (unit 13 in Senior 5) and in addition performance of the activity provided to introduce this unit.

b. Teaching resources

The resources like a projector, chalkboard, worksheets, etc may be used in teaching/ learning this lesson.

c. Learning activities

This is a very short lesson do not waste a lot of time. It is better to teach it together with the general introduction of the unit (just with the introductory activity).

- Only allow your students (in pairs) to formulate their own definitions of the electrochemical cell from the introductory activity done previously.
- Let some students (3-5 depending on the time left) present their definitions and comment on the missing to be a complete definition.
- Give to the student a complete definition as given by the answer to activity 12.1 below which already asked the definition.

Answer to Activity 12.1

An **electrochemical cell** is a device which is capable of either producing electrical energy from chemical reactions or causes chemical reactions to take place through the introduction of electrical energy.

Lesson 2: Description of electrochemical cells

a. Prerequisites/Revision/Introduction

For better describing the electrochemical cells, the prior knowledge in electrolysis and electrolytic cells, the half-reactions at electrodes and the reduction and oxidation reactions, as required to be studied in Senior 4 (unit 17) and Senior 5 (unit 13), are needed.

b. Teaching resources

Video player, a projector, chalkboard, worksheets, flip chart paper, laboratory materials, etc.

c. Learning activities

We have two learning activities in this long lesson.

The first activity is a practical activity that must be carried out in the laboratory.

Put the students into groups of 6 to 8 depending on the size of your class.

- Provide them with the activity 12.2 (a). Here use the possible methods (the chalkboard, books, worksheets or projector).
- Give them time between 20 and 25 minutes to read, analyze, perform the experiment, interpret, discuss and answer questions about the activity.
- Ask 4 groups to present their findings by writing and drawing on the chalkboard..
- Allow some students to comment about the findings of their colleagues presented.

- Take this time to use some questions in order to draw the conclusion which is in line with the objectives of the unit (using the answers being provided by student).
- Give them the homework (in groups) of using the Student Book and making any other research to be able to deal with the following:
 1. What is a half-cell and how a galvanic cell is constructed from the half-cells
 2. Describe the Standard Hydrogen Electrode as it is used to determine Standard Electrode Potentials.
 3. Cell diagram/notation
 4. Calculation of electromotive force (emf).
 (Divide the topics to different groups)
- In the next sessions, invite two groups for each topic to present and after allow some students comment about the presented. Do the same as one after one and when all topics are discussed, do what you did on the previous activity to draw a conclusion.
- After topic (1), give them the activity 12.2 (b) and ask groups having in charge topic (2), to answer it quickly.
- After topic (2) has been presented and discussed, give them the checking up 12.2 (a) in pairs and collect the worksheets for correction. Here the comments will be given in the next session before starting to present next topic (the topic 3).
- When the whole lesson has been dealt (all topics have been discussed on), give student the checking up 12.2 (b) as homework to be done and submitted in groups of 4.

Proposed Answers to Activity 12.2 (a)

1. Answer: The ionic equations are:

- At Anode: Anode: is an electrode at which oxidation occurs. Because it is the source of electrons, in voltaic cell, it is also called the negative electrode.
- $$\text{Zn(s)} \rightarrow \text{Zn}^{2+}(\text{aq}) + 2\text{e}^{-}$$
- At Cathode: Cathode: is an electrode at which reduction occurs. Because it is the receiver of electrons, in voltaic cell, it is also called the positive electrode.



Total cell reaction is the sum of the two half-cell reactions:

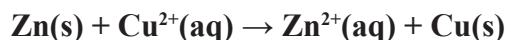

2. See the Student's Book.
3. See the Student's Book.

Answers to Activity 12.2 (b)

Some electrode potentials experimentally measured are found in the *table 12.3*. Use any document to:

1. They are called “standard” because they are measured in standard conditions (Temperature: 25 °C, Pressure: 1 atm, Concentration: 1 M)
2. Description of the way the electrode potential given for an atom can be measured (See Student’s Book)

Application activities (Answers)

Answers to Checking Up 12.2 (a)

1. Standard electrode potential is the potential measured with respect to a standard hydrogen electrode (SHE) at 25 °C with 1 M concentration of each ion in solution and 1 atm of pressure of each gas involved.
2. Yes, it is possible to use another. In fact, the hydrogen electrode is not a convenient reference electrode to use in measurements because maintaining a stream of hydrogen at 1 atm takes careful management. Thus, secondary standards are employed, such as the saturated calomel electrode.
3. Answers.
 - a. True
 - b. False
4. With the aid of a diagram, explain how the standard electrode potential of zinc is measured.

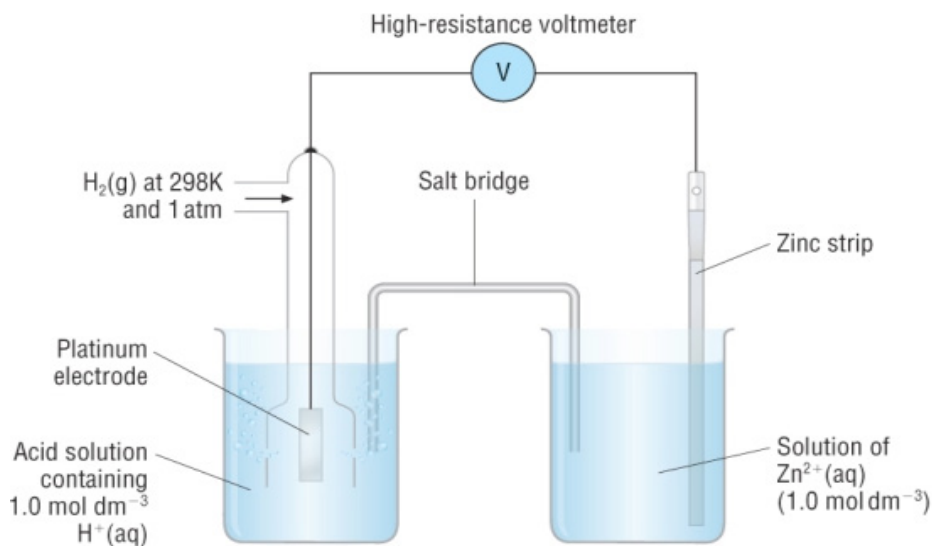

5. **A** = Hydrogen at 1 atm, **B** = Inner glass tube, **C** = 1M HCl, **D** = Platinum

Answers to checking up 12.2 (b)

Question 1

a. To remove the oxide layer on the aluminium

b. An appropriate method for delivering H₂ gas over a Pt electrode

Need H₂ gas and Pt electrode labelled (allow gas delivered directly below the electrode).

The Pt electrode must clearly be in contact with a solution of a named acid

c. The carbonate ion reacts with the acid (in the SHE) / reaction between carbonate and Al³⁺

OR H⁺ / Al³⁺ concentrations change / cell e.m.f. altered.

Question 2

a. Pressure: 101.3 kPa (1.013 x 10⁵Pa)

Temperature: 25°C (298K)

b. Salt bridge

c. Anode

Mg is a stronger reducing agent than H₂ and (Mg) will be oxidised.

Mg undergoes an oxidation reaction in this setup

d.

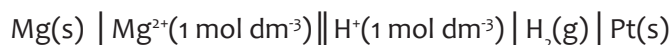

$$e. E_{\text{Cell}}^{\theta} = E_{\text{Cathode}}^{\theta} - E_{\text{Anode}}^{\theta} \quad E_{\text{Cell}}^{\theta} = E_{\text{Cathode}}^{\theta} - E_{\text{Anode}}^{\theta}$$

$$2.36 = 0.00 - (E_{\text{Anode}}^{\theta} - E_{\text{Anode}}^{\theta})$$

$$E_{\text{Cell}}^{\theta} = -2.36 \text{ V}$$

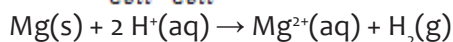

Question 3

a. Temperature = 25 °C (298K)

Concentration (of electrolytes) = 1 mol.dm³

b. Emf / potential difference

(i) (Half-cell) A

(ii) (Half-cell) B

c. (i) A

(ii) B

d. (Combination) AB

e. (i) Magnesium (Mg)

It is oxidised (loses electrons), increases in oxidation number (stronger reducing agent).

$$\begin{aligned} \text{(ii)} E_{\text{Cell}}^{\theta} &= E_{\text{Cathode}}^{\theta} - E_{\text{Anode}}^{\theta} \\ E_{\text{Cell}}^{\theta} &= E_{\text{Cathode}}^{\theta} - E_{\text{Anode}}^{\theta} \\ &= -0.13 - (-2.36) = -0.13 - (-2.36) \end{aligned}$$

$$E_{\text{Cell}}^{\theta} = 2.23 \text{ V}$$

(iii) Increases

Use equilibrium shifts to work out answer.

(iv)

- Allows for the migration of positive ions to the cathode half-cell.
- Allows for the migration of negative ions to the anode half-cell.

Question 4

a. Increases

The reaction is exothermic.

Energy (heat) is released

$$\Delta H < 0$$

b. Aluminium is a stronger reducing agent than copper and will reduce the copper (II) ions to copper.

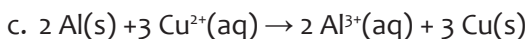

Question 5

a. Al (Aluminium)

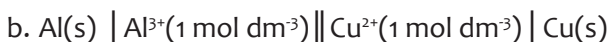

$$\begin{aligned} \text{c. } E_{\text{Cell}}^{\theta} &= E_{\text{Cathode}}^{\theta} - E_{\text{Anode}}^{\theta} \\ E_{\text{Cell}}^{\theta} &= E_{\text{Cathode}}^{\theta} - E_{\text{Anode}}^{\theta} \\ &= 0.34 - (-1.66) = 0.34 - (-1.66) \end{aligned}$$

$$E_{\text{Cell}}^{\theta} = 2.00 \text{ V}$$

d. The salt bridge is now removed.

Zero Volts (0 V)

The circuit is open.

Question 6

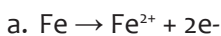

b. Oxygen

$$\begin{aligned} \text{c. } E_{\text{Cell}}^{\theta} &= E_{\text{Cathode}}^{\theta} - E_{\text{Anode}}^{\theta} \\ E_{\text{Cell}}^{\theta} &= E_{\text{Cathode}}^{\theta} - E_{\text{Anode}}^{\theta} \\ &= 0.4 - 0.44 = 0.4 - 0.44 \end{aligned}$$

$$E_{\text{Cell}}^{\theta} = 0.84 \text{ V}$$

Because E°_{cell} is positive, the reaction is spontaneous

Lesson 3: Prediction of spontaneity of redox reactions

a. Prerequisites/Revision/Introduction

For having a good understanding in predicting the spontaneity of redox reactions, it is better to have prior knowledge about reduction and oxidation reactions, as required to be studied in Senior 4 (unit 17), calculations of the electromotive force of the cell (already studied in this unit, the previous lesson) and Gibbs free energy as studied in the unit 15 “entropy and free energy” of Senior 5.

b. Teaching resources

Computer, a projector, chalkboard, worksheets, apparatus, etc

c. Learning activities

Before starting this lesson, make sure that you gave homework about how the spontaneity of a redox reaction can be predicted using the electromotive force (e.m.f.) and/or Gibbs free energy.

At the time to teach this lesson, begin with giving the practical activity 12.3 that must be done in the chemistry laboratory.

- Put your students in groups of 6.
- Provide them with the activity 12.3 (you can use the chalkboard, books, and worksheets or even use the projector).
- Give them time between 35 and 45 minutes to read, analyze, work out the experiment, interpret, discuss and answer questions about the activity.
- Ask 3 groups to present their findings and 3 other groups to present about the homework.
- Allow some students to comment about the findings of their colleagues presented.
- Take this time to use some questions in order to draw the conclusion which is in line with the objectives of the unit (using the answers being provided by student).
- Give them the checking up 12.3 in pairs in 15 min and collect worksheets to be corrected, once you return in the class with corrected copies, remember to give feedback.

Proposed answers to Activity 12.3

Discussion questions:

1. Indicate with a check mark (✓) if there is evidence of a reaction.

Metal / Solutions	Cu(NO ₃) ₂	AgNO ₃	Pb(NO ₃) ₂	Zn(NO ₃) ₂
Cu (s)	X	✓	X	X
Fe (s)	✓	✓	✓	X
Pb (s)	✓	✓	X	✓
Zn (s)	✓	✓	✓	✓

2 Non-ionic and net ionic reactions, spontaneity, oxidised and reduced species, half reaction of reduction, oxidising and reducing agents.

<p>a) $\text{Fe(s)} + \text{Cu(NO}_3)_2 \rightarrow \text{Fe(NO}_3)_2 + \text{Cu(s)}$ $\text{Fe(s)} + \text{Cu}^{2+}(\text{aq}) \rightarrow \text{Fe}^{2+}(\text{aq}) + \text{Cu(s)}$ Spontaneous Oxidised species: Fe(s) Reduced species: Cu²⁺(aq) Half reaction: $\text{Cu}^{2+}(\text{aq}) + 2\text{e}^- \rightarrow \text{Cu(s)}$ Oxidising agent: Cu²⁺(aq) Reducing agent: Fe(s)</p>	<p>f) $\text{Pb(s)} + \text{AgNO}_3 \rightarrow \text{Pb(NO}_3)_2 + \text{Ag(s)}$ $\text{Pb(s)} + \text{Ag}^+(\text{aq}) \rightarrow \text{Pb}^{2+}(\text{aq}) + \text{Ag(s)}$ Spontaneous Oxidised species: Pb(s) Reduced species: Ag⁺(aq) Half reaction: $\text{Ag}^+(\text{aq}) + \text{e}^- \rightarrow \text{Ag(s)}$ Oxidising agent: Ag⁺(aq) Reducing agent: Pb(s)</p>
<p>b) $\text{Pb(s)} + \text{Cu(NO}_3)_2 \rightarrow \text{Pb(NO}_3)_2 + \text{Cu(s)}$ $\text{Pb(s)} + \text{Cu}^{2+}(\text{aq}) \rightarrow \text{Pb}^{2+}(\text{aq}) + \text{Cu(s)}$ Spontaneous Oxidised species: Pb(s) Reduced species: Cu²⁺(aq) Half reaction: $\text{Cu}^{2+}(\text{aq}) + 2\text{e}^- \rightarrow \text{Cu(s)}$ Oxidising agent: Cu²⁺(aq) Reducing agent: Pb(s)</p>	<p>g) $\text{Zn(s)} + \text{AgNO}_3 \rightarrow \text{Zn(NO}_3)_2 + \text{Ag(s)}$ $\text{Zn(s)} + \text{Ag}^+(\text{aq}) \rightarrow \text{Zn}^{2+}(\text{aq}) + \text{Ag(s)}$ Spontaneous Oxidised species: Zn(s) Reduced species: Ag⁺(aq) Half reaction: $\text{Ag}^+(\text{aq}) + \text{e}^- \rightarrow \text{Ag(s)}$ Oxidising agent: Ag⁺(aq) Reducing agent: Zn(s)</p>

<p>c) $\text{Zn(s)} + \text{Cu(NO}_3)_2 \rightarrow \text{Fe(NO}_3)_2 + \text{Cu(s)}$ $\text{Zn(s)} + \text{Cu}^{2+}(\text{aq}) \rightarrow \text{Fe}^{2+}(\text{aq}) + \text{Cu(s)}$ Spontaneous Oxidised species: Zn(s) Reduced species: $\text{Cu}^{2+}(\text{aq})$ Half reaction: $\text{Cu}^{2+}(\text{aq}) + 2\text{e}^- \rightarrow \text{Cu(s)}$ Oxidising agent: $\text{Cu}^{2+}(\text{aq})$ Reducing agent: Zn(s)</p>	<p>h) $\text{Fe(s)} + \text{Pb(NO}_3)_2 \rightarrow \text{Fe(NO}_3)_2 + \text{Pb(s)}$ $\text{Fe(s)} + \text{Pb}^{2+}(\text{aq}) \rightarrow \text{Fe}^{2+}(\text{aq}) + \text{Pb(s)}$ Spontaneous Oxidised species: Fe(s) Reduced species: $\text{Pb}^{2+}(\text{aq})$ Half reaction: $\text{Pb}^{2+}(\text{aq}) + 2\text{e}^- \rightarrow \text{Pb(s)}$ Oxidising agent: $\text{Pb}^{2+}(\text{aq})$ Reducing agent: Fe(s)</p>
<p>$\text{Cu(s)} + \text{AgNO}_3 \rightarrow \text{Cu(NO}_3)_2 + \text{Ag(s)}$ $\text{Cu(s)} + \text{Ag}^+(\text{aq}) \rightarrow \text{Cu}^{2+}(\text{aq}) + \text{Ag(s)}$ Spontaneous Oxidised species: Cu(s) Reduced species: $\text{Ag}^+(\text{aq})$ Half reaction: $\text{Ag}^+(\text{aq}) + \text{e}^- \rightarrow \text{Ag(s)}$ Oxidising agent: $\text{Ag}^+(\text{aq})$ Reducing agent: Cu(s)</p>	<p>i) $\text{Zn(s)} + \text{Pb(NO}_3)_2 \rightarrow \text{Zn(NO}_3)_2 + \text{Pb(s)}$ $\text{Zn(s)} + \text{Pb}^{2+}(\text{aq}) \rightarrow \text{Zn}^{2+}(\text{aq}) + \text{Pb(s)}$ Spontaneous Oxidised species: Zn(s) Reduced species: $\text{Pb}^{2+}(\text{aq})$ Half reaction: $\text{Pb}^{2+}(\text{aq}) + 2\text{e}^- \rightarrow \text{Pb(s)}$ Oxidising agent: $\text{Pb}^{2+}(\text{aq})$ Reducing agent: Zn(s)</p>
<p>e) $\text{Fe(s)} + \text{AgNO}_3 \rightarrow \text{Fe(NO}_3)_2 + \text{Ag(s)}$ $\text{Fe(s)} + \text{Ag}^+(\text{aq}) \rightarrow \text{Fe}^{2+}(\text{aq}) + \text{Ag(s)}$ Spontaneous Oxidised species: Fe(s) Reduced species: $\text{Ag}^+(\text{aq})$ Half reaction: $\text{Ag}^+(\text{aq}) + \text{e}^- \rightarrow \text{Ag(s)}$ Oxidising agent: $\text{Ag}^+(\text{aq})$ Reducing agent: Fe(s)</p>	

3. Best reducing agent: Zinc (Zn)

4. Order of reducing agents (list): Zn>Fe>Pb>Cu

Application activities (Answers)

Answers to Checking up 12.3

Question 1

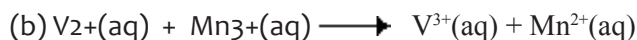

(c) $EMF = E^{\ominus}_{\text{cathode}} - E^{\ominus}_{\text{anode}} = +1.5 + 0.26 = 1.76 \text{ V}$;

(d) The reaction is possible because the overall EMF is positive.

Question 2

(a) $\Delta G^{\circ} = -nFE^{\circ}_{(\text{cell})}$

n in the above equation is 2, $F = 96,487 \text{ C mol}^{-1}$ and $E_{(\text{cell})} = 1.1 \text{ V}$

Therefore, $\Delta G^{\circ} = -2 \times 1.1 \text{ V} \times 96,500 \text{ C mol}^{-1}$

$$= -212,300 \text{ J mol}^{-1}$$

$$= -212.3 \text{ kJ mol}^{-1}$$

(b) It is spontaneous because the free energy is negative.

Lesson 4: Explanation of the effect of concentration on electromotive force of the cell

a. Prerequisites/Revision/Introduction

For explaining the effect of concentration on electromotive force of a cell, it requires to already know the electrochemical cells as it might be studied in this unit and the factors that affect chemical equilibrium as studied in Senior 4, unit 15 and also in quantitative chemical equilibrium studied in Senior 6, unit 8.

b. Teaching resources

Computer, projector, chalkboard, worksheets, apparatus, voltmeter, etc

c. Learning activities

For gauging the effect of concentration on electromotive force of the cell, use the **activity 12.4** as instructed here below.

- Put your students in groups of 4.
- Provide them with the **activity 12.4** (use the affordable materials like the chalkboard, books, and worksheets or even use the projector).
- Give them time between 20 and 25 minutes to work out the activity.
- Ask some groups to present their findings.
- Allow some students to comment about the findings of their colleagues presented.
- Take this time to use the question method in order to draw the conclusion which is in line with the objectives of the unit (using the answers being provided by

student).

- Give them the **checking up 12.4** as homework, after correcting copies remember to give feedback to students.

Answers to Activity 12.4

1. If you decrease the concentration of something in equilibrium, the position of equilibrium shifts in such a way as to counteract the change (Le Chatelier's Principle).
2. The position of equilibrium moves to the left, tending to increase the concentration of the copper ions again. But the E° value gives a measure of the position of the equilibrium. If the position of the equilibrium moves to the left, then the electrode potential becomes less positive. (It is no longer a *standard* electrode potential because the concentrations are no longer standard.)
3. See the Student Book

Application activities (Answers)

Answers to Checking up 12.4

1. (a) The second cell; (b) 0.105 V

2. $K = 1.2 \times 10^{-10}$

3. The cell reaction is: $\text{Zn(s)} + 2\text{H}^+(\text{aq}) \rightarrow \text{Zn}^{2+}(\text{aq}) + \text{H}_2(\text{g})$

The standard emf is $E^\circ = +0.76$ V. It is apparent that $n = 2$ for this reaction, and we are given that $[\text{Zn}^{2+}] = 1.0$ M and $p_{\text{H}_2} = 1.0$ atm (recall that gas pressures must be in *atm* for calculations involving Q).

$$= 0.76 - \frac{0.0592}{2} \log \frac{1.0}{[\text{H}^+]^2} = 0.76 - \frac{0.0592}{2} \log \frac{1.0}{[\text{H}^+]^2}$$

From the properties of logarithms:

$$\log \frac{1}{x^2} = -\log x^2 = -2 \log x \log \frac{1}{x^2} = -\log x^2 = -2 \log x$$

We can therefore write $0.45 = 0.76 - \frac{0.0592}{2} (-2 \log[\text{H}^+])$

$$0.45 = 0.76 - \frac{0.0592}{2} (-2 \log[\text{H}^+])$$

Solving for $\log [\text{H}^+]$ gives:

$$\log[\text{H}^+] = \frac{0.45 - 0.76}{0.0592} = -5.2 \log[\text{H}^+] = \frac{0.45 - 0.76}{0.0592} = -5.2$$

$$[\text{H}^+] = 10^{-5.2} = 6 \times 10^{-6} \text{ M}$$

$$[\text{H}^+] = 10^{-5.2} = 6 \times 10^{-6} \text{ M}$$

This example shows how a voltaic cell whose cell reaction involves H^+ can be used to measure $[H^+]$ or pH . A pH meter is a specially designed voltaic cell with a voltmeter calibrated to read pH directly.

Lesson 5: Explanation of corrosion and its effects on metallic objects

a. Prerequisites/Revision/Introduction

For better understanding corrosion as an electrochemical process and its effects on metallic objects, it is required to know the reduction and oxidation reactions, as required to be studied in Senior 4 (unit 17), electrochemical cell description as must be studied previously in this unit and electrolysis and electrolytic cells, the half-reactions at electrodes and the processes like electroplating, galvanising or anodisation studied in Senior 5 (unit 13).

b. Teaching resources

Video player, a projector, computer machine, chalkboard, worksheets, flip chart paper, etc

c. Learning activities

- Put your students in groups of 6.
- Provide them with the **activity 12.5** (you can use the chalkboard, books, and worksheets or even use the projector).
- Give them time between 15 and 25 minutes to answer the questions of this activity.
- Invite 3 groups chosen randomly to present their findings.
- Allow some students to comment about the findings of their colleagues presented.
- Take this time to give additional information (missing in what found by all groups) and use some questions to draw the conclusion.
- Give them the **checking up 12.5** in pairs to be completed in 10 min and collect worksheets to be corrected, once you return in the class with corrected copies, remember to give feedback.

Answer to Activity 12.5

1. This is known as *corrosion*.
2. We know that metals are highly reactive elements due to less number of valence electrons therefore they tend to lose electrons during chemical reactions. Corrosion is also a chemical reaction in which metal reactions with atmospheric moisture and oxygen gas to form metallic oxides. That is the reason, metals corrode quickly.
3. Some effect of corrosion on metallic objects:
 - Loss of efficiency
 - Contamination of product

- Damage of metallic equipments
- Inability to use metallic materials
- Loss of valuable materials such as blockage of pipes, mechanical damage of underground water pipes, etc.

Application activities (Answers)

Answers to Checking up 12.5

- $\text{Fe (s)} \rightarrow \text{Fe}^{2+}(\text{aq}) + 2 \text{e}^{-}$
- $\text{O}_2(\text{g}) + 2 \text{H}_2\text{O (l)} + 4 \text{e}^{-} \rightarrow 4 \text{OH}^{-}(\text{aq})$
- The presence of salt (or any electrolyte) in the water accelerates the reaction because it increases the conductivity of water, effectively increasing the concentration of ions in the water and so increasing the rate of oxidation (corrosion) of the metal.
- Magnesium and Zinc. Magnesium and zinc are often used as sacrificial metals. They are more reactive than iron and lose their electrons in preference to iron. Although tin is used to coat steel cans, it does not act as a sacrificial metal.

Lesson 6: Applications of electrochemical cell

a. Prerequisites/Revision/Introduction

Understanding the working and applications of electrochemical cell, you should know better the functioning of an electrochemical cell (as studied in the previous lessons of this unit) and redox reactions at electrodes.

b. Teaching resources

Computer, video player, a projector, chalkboard, worksheets, flip chart paper, books, etc

c. Learning activities

This lesson may take many periods. The **activity 12.6**, once used correctly, will help to study well the working and applications of electrochemical cells. To be successful, this activity can be given as homework before studying this lesson.

- Before studying this lesson, give **activity 12.6** as homework in groups of 6 to be submitted and presented in the beginning of this lesson.
- Let the students be in their respective groups (those used in working the homework).
- Invite the representative of each group to present their findings (one after one). Here give instructions to follow attentively and take notes for the important points especially half-equations at electrodes.
- After all groups have just presented, harmonise by allowing some students to comment about the findings of their colleagues presented.

- After this, add the main information missing and correct the common mistakes made.
- At the end of this lesson, remember to give the **checking up 12.6** in groups of 4 that must be worked out in a suitable time and must be submitted to be corrected.
- After correcting all worksheets, remember to give feedback.

Answer to Activity 12.6

1. Generation of electricity
2. Use the Student's Book to answer this question.
3. Cells ('batteries') can be:
 - **Non-rechargeable** (irreversible) where the chemicals are used up.
 - **Rechargeable**, where the chemistry generating the electrical current can be reversed, so charging up the battery again, and the chemicals are not used up,
 - **Fuel cells**, which must be continuously fed chemicals e.g. fuel plus oxidant to maintain the chemistry producing the electrical current. Fuel cells used to generate an electric current do not need to be electrically recharged.
 - **PRIMARY CELLS** are not rechargeable and are discarded, after they run down when all the chemicals are used up i.e. no more chemical potential energy available
 - **SECONDARY CELLS** can be recharged after they have run down i.e. the discharge reactions producing the electricity are reversed to build up the store of chemical potential energy.
 - **FUEL CELLS** produce electricity directly from gaseous or liquid fuels such as hydrogen or hydrocarbons with only safe waste products of water or carbon dioxide.

Application activities (Answers)

Answers to Checking up 12.6

Question 1

- a. Secondary because it can be recharged by passing direct current through them and can be used again and again.
- b. $\text{Pb} + \text{PbO}_2 + 2 \text{H}_2\text{SO}_4 \rightarrow 2 \text{PbSO}_4 + 2 \text{H}_2\text{O}$
Or $\text{Pb} + \text{PbO}_2 + 2 \text{HSO}_4^- + 2\text{H}^+ \rightarrow 2 \text{PbSO}_4 + 2 \text{H}_2\text{O}$
- c. $E_{\text{Cell}}^{\theta} = E_{\text{Cathode}}^{\theta} - E_{\text{Anode}}^{\theta}$
 $= 1.70 - (-0.36)$
 $= 2.06 \text{ V}$

Emf of cell battery = $6 \times 2.06 = 12.36 \text{ V}$

d. Environmental risks

- Acid used as electrolyte can contaminate groundwater.
- Plastic casings are non-degradable and can pollute the environment.
- Lead (in electrodes) is a heavy metal and can harm crops / plants.

Question 2

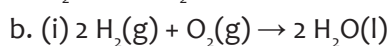
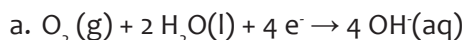

(ii) $\text{EMF} = 0.88 + 0.40 = 1.23 \text{ V}$

(iii) From the hydrogen half cell to the oxygen half cell.

c. As a catalyst

d. Water produced during the cell reaction can be consumed by an astronaut. The cell can supply electricity indefinitely as long as the supply of hydrogen and oxygen is not discontinued.

Question 3

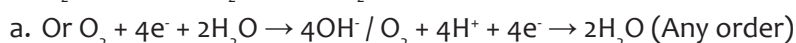
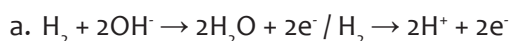

b. Hydrogen (electrode) produces electrons and Oxygen (electrode) accepts electrons/Electrons flow to the oxygen electrode

c. Hydrogen / The fuel / Reactants are supplied continuously.

d. Hydrogen-oxygen fuel cell can produce drinking water of potable quality because the residual product discharged by the hydrogen-oxygen cell is water which is in its pure form.

e. (i) In the fuel cell, a greater proportion of the energy available from the hydrogen–oxygen reaction is converted into useful energy/Less energy wasted / More efficient

(ii) Hydrogen is flammable / H^+ corrosive / OH^- corrosive / Hydrogen explosive

Question 4

a. Primary cells

b. Equation 2

- This is a reduction equation
- Reduction takes place (at the cathode)

c. any one:

- The cell reaction reaches equilibrium.
- The rates of the forward and reverse reactions become equal.
- Substances reach their equilibrium concentrations.

Question 5

a. Secondary cells

b. Equation II

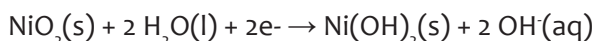

Reduction (takes place at cathode).

Electrons gained (at cathode)

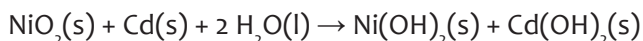

Question 6

a. Electrolyte is a paste/not a liquid

b. The acid in the battery attacks (reacts with) the zinc, causing it to corrode faster than the alkaline-based battery.

c. Rechargeable batteries can be re-used and less is manufactured/transported - less greenhouse gases emitted

OR

More primary batteries need to be manufactured as they cannot be re-used and transportation / manufacturing leads to emission of greenhouse gases.

Question 7

a. The build-up of $\text{H}_{2(\text{g})}$ in the cell could cause the cell to burst or explode if ignited.

In a zinc-carbon cell, such as the one above, half-reaction (iii) and the half-reaction that takes place in the Zn/Zn^{2+} half-cell, produce an emf of 1.5 V under standard conditions.

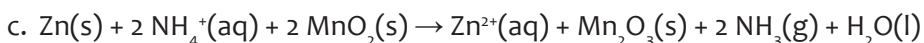
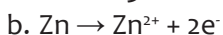

d. NH_4^+ is an acid and reacts with the zinc casing.

e. Can be reused as an electrode in other situations.

Lesson 7: Comparison between galvanic (voltaic) cell and electrolytic cell

a. Prerequisites/Revision/Introduction

For comparing electrochemical cell and electrolytic cell, you must have the knowledge and skills about all these types of electrochemical cells i.e. electrolytic cell (as studied in electrolysis of Senior 4 (unit 17) and voltaic cell (as studied in this unit 12 of Senior 6 (unit 13)).

b. Teaching resources

Chalkboard, worksheets, flip chart paper, etc

c. Learning activities

This lesson must be started in the laboratory in order to be able to work out the learning activity proposed.

- Put your students in groups of 6.
- Provide them with the **activity 12.7** (you can use the chalkboard, books, and worksheets or even use the projector).
- Give them time between 15 and 25 minutes to read, analyze, work out the experiment, interpret, discuss and answer questions about the activity.
- Ask 3 groups to present their findings and submit this work to be corrected.
- Allow some students to comment about the findings of their colleagues presented.
- Take this time to use some questions in order to draw the conclusion which is in line with the objectives of the unit (using the answers being provided by student).
- Give them the **checking up 12.7** as homework and collect worksheets to be corrected, once you return in the class with corrected copies, remember to give feedback.

Answer to Activity 12.7

1. Carbon (graphite) electrode is coated with copper metal.
 - a. $\text{Cu}^{2+}(\text{aq}) + 2 \text{e}^- \rightarrow \text{Cu}(\text{s})$
 - b. $4\text{OH}^-(\text{aq}) \rightarrow \text{O}_2 + \text{H}_2\text{O}(\text{aq}) + 4\text{e}^-$
 - c. Graphite electroplating/separation of copper
2.
 - a. **Galvanic cell** is a device which converts chemical energy into electrical energy.
 - b. **Electrolytic cell** is a device which converts electrical energy into chemical energy.
3. See the Student's Book

Application activities (Answers)

Answers to Checking up 12.7

1. See the Student' Book
2. (a)
3. (a)
4. (b)
5.
 - a. Electrolytic
 - b. (i) A
 - c. (ii) B
 - d. (i) Remains the same

The rate of oxidation of copper at the anode is equal to the rate of reduction of copper(II) ions at the cathode.

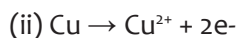

e. (i) It contains precious metals (valuable, expensive metals.)

(ii) Consumes large amount of electricity (energy).

Depletes coal resources/Contributes to global warming/Habitats destroyed in mining of coal/Contributes to acid rain.

6.

a. DC

b. Free ions needed to conduct electricity.

c. (i) Cathode: $\text{Cu}^{2+} + 2\text{e}^- \rightarrow \text{Cu}$

d. (ii) $\text{Cu} \rightarrow \text{Cu}^{2+} + 2\text{e}^-$

e. (i) Pt is a weaker reducing agent than Cu and will not be oxidized/Cu is a stronger reducing agent than Pt and will be oxidised.

The platinum will not react at all, and will just be left over at the end.

(ii) Remains the same

The rate at which Cu is oxidised at the anode equals the rate at which $\text{Cu}^{2+}(\text{aq})$ is reduced at the cathode.

12.6. Summary of the unit

This unit deals with electrochemical cells and their applications. An electrochemical cell is a device which is capable of either producing electrical energy from chemical reactions or causes chemical reactions to take place through the introduction of electrical energy. There are two types of electrochemical cells: galvanic (voltaic) and electrolytic cells.

Oxidation-reduction (or redox) reactions take place in electrochemical cells where spontaneous reactions occur in galvanic (voltaic) cells; non-spontaneous reactions occur in electrolytic cells. Oxidation occurs at the **anode** and reduction occurs at the **cathode**.

The anode of an electrolytic cell is positive whereas the cathode is negative. In a galvanic cell, the anode is negatively charged and the cathode of a galvanic cell is its positive terminal.

In both galvanic and electrolytic cells, oxidation takes place at the anode and electrons flow from the anode to the cathode. In a galvanic cell, each electrode is immersed in an electrolyte containing its own ions (in the separate containers) and these form a half cell. A simple electrochemical cell can be made by connecting together two half cells with different electrode potentials. The oxidation occurs at one half-cell and reduction at another.

Standard Hydrogen Electrode (SHE) is used to measure “standard electrode potential” but also saturated calomel electrode can be used as a secondary standard. *Electromotive force is also known as cell voltage or cell potential, and it is measured in volts. Conveniently, an electrochemical cell can be represented by writing a cell notation than by making a drawing.*

If the E° will be positive, the reaction is spontaneous; if it is zero, a redox reaction is at equilibrium and if the E° is negative, the reaction is not spontaneous. In order for a reaction to proceed spontaneously, $\Delta G < 0$, and if ΔG is negative, then E_{cell} must be positive.

If the concentrations of reactants increase relative to those of products, the cell reaction becomes more spontaneous and the emf increases. If the concentrations of products increase relative to reactants, the emf decreases. As voltaic cell operates, reactants are converted into products and this increases the value of Q and causes the emf to decrease.

The concentration cell is a voltaic cell with a non-zero emf can be constructed using the same species in both the anode and cathode compartments as long as the concentrations are different. Metal corrosion causes metal destruction and the most common corrosion process is the rusting of iron which is an electrochemical process.

The importance of electrochemical cells or galvanic cells lies in their ability to provide us with a portable source of electrical energy. Quite often, we use the term “battery” to represent the arrangement of two or more galvanic cells connected in series. The galvanic cells can be broadly classified into three categories, namely primary cells, secondary cells and fuel cells.

Primary cells are the type of cells that become dead over a period of time and the chemical reaction stops. They cannot be recharged or used again. Some common examples are dry cell, mercury cell, etc.

Secondary cells are the type of cells that can be recharged by passing direct current through them and can be used again and again. These are the types of batteries found in devices such as smart phones, electronic tablets, and automobiles. Some examples are lead-storage battery, nickel-cadmium storage cell, etc.

Electrolytic and voltaic cells are very similar as but also they have striking differences between these two cells.

12.7. Additional information for teachers

I. INTRODUCTION

Electrochemistry refers to the conversion of chemical energy to electrical energy and vice versa. It is basically the study of Production of electricity from energy released during spontaneous reaction and use of electrical energy to bring about non-spontaneous chemical transformation.

A spontaneous chemical reaction is a reaction which happens on its own and releases free energy. This reaction produces electric energy from chemical reaction. For example: burning of coal, rusting of iron, melting of ice, etc. On the other hand non-spontaneous reaction occurs by providing an external source like electricity. For example: Hydrolysis of water.

Electrochemistry is used for the following purposes.

- Production of metals like sodium hydroxide, chlorine, fluorine and many other chemicals.
- It is also used for purification of metals.
- The process is used in batteries as well as fuel cells which converts the chemical energy into electrical energy and is used in several instruments and devices.
- This process is used in electroplating.
- The reactions carried out using the process of electrochemistry are energy effective and less polluting.

II. ELECTROCHEMICAL CELLS

These have been around for a long time as a portable source of energy. We call them batteries. The original batteries were zinc-copper voltaic cells and as technology progressed they moved to zinc - manganese dioxide so called 'dry-cells' and nowadays there are a whole range of different cells including rechargeable nickel and tiny lithium ion cells.

We can divide the electrochemical cells used today into three kinds:

- 1 non-rechargeable
- 2 rechargeable
- 3 fuel cells

The first two kinds are both storage batteries as they store the chemicals needed to produce electricity within the battery.

1. NON-RECHARGEABLE BATTERIES

Non-rechargeable cells are cells where the reaction cannot safely be reversed inside the cell.

Zinc and Manganese Dioxide are the two chemicals used in a non-rechargeable cell.

A non-rechargeable battery can be used until it runs out of charge at which time it is useless and must be disposed.

The original experiment done by Alessandro Volta in 1800 used discs of copper and discs of zinc alternating with damp pads between them. He found that by connecting wires to the top and bottom disc and electrical charge passed around the external circuit and that the voltage was proportional to the number of discs used.

He called this device a '**pile**' as it was a pile of discs on top of one another. Later the term **battery**, which means a series of units side by side, came to be introduced:

It is easy to work out the approximate voltage produced by such a pile.

2. RECHARGEABLE BATTERIES

Rechargeable cells are cells where the chemical reaction can be reversed inside. Lead and Lead (IV) dioxide are used in one type, other examples are nickel-cadmium or lithium ion cells.

A rechargeable battery can undergo many cycles of use - recharge and re-use. Eventually they also reach the end of their lifetimes when they cannot be charged any more. A common example is the lead-acid car battery.

Advantages and Disadvantages

Cost: Non-rechargeable batteries are cheaper in the short run but rechargeable batteries don't have to be replaced

Lifetime: Non-rechargeable batteries will run for longer but rechargeable batteries have to be disposed of when they run out.

Power: Rechargeable batteries supply more power than non-rechargeable

Resources and Waste: Non-rechargeable batteries need to be constantly remade and chucked away however they don't contain toxic metals so aren't as hazardous when disposed of

3. FUEL CELLS

Fuel cells are cells where the chemicals are fed into the cell. Fuel cells provide a continuous supply of fuel and will run for as long as supply is maintained. For example the hydrogen - oxygen fuel cell provides a supply of hydrogen gas and oxygen gas to the cell, where it reacts producing electricity. In a hydrogen-oxygen fuel cell Hydrogen and oxygen are fed in to opposite platinum electrodes. H⁺ ions are then filtered through to the oxygen platinum cathode where water is made. Some Problems with fuel cells

- Hydrogen needs to be created which requires electricity.
- Hydrogen is also highly flammable.

III. GALVANIC CELLS AND ELECTROLYTIC CELLS

There are two types of electrochemical cells: galvanic cells – with spontaneous redox processes that allow continuous flow of electrons through the conductor, whereby the chemical energy is transformed into an electrical one; and electrolytic, where the redox reactions are influenced by an external source of current, where the electricity is converted in chemical energy.

1. UNDERSTANDING GALVANIC CELLS AND ELECTROLYTIC CELLS

What is Galvanic Cell?

Galvanic cells are systems in which the chemical energy is transformed into electrical and as a result current is generated. In galvanic cells, direct current is generated as a result of the redox (oxidation-reduction) process. The galvanic element consists of two half-cells. The half-cell consists of the electrolyte and the immersed electrode in it. Between these half-cells a contact must be provided, connecting the electrolyte with a salt bridge or semi-conductive membrane and connecting the electrode with conductor.

The separation of the redox process is explained by the electrodes' behavior in relation to the electrolyte. The simplest option is that the half-cell is formed of a metal electrode immersed in an electrolyte containing ions correspondent with the electrode. The behavior of metals in the electrolyte depends on the reactivity of the metal i.e. its tendency to dissolve.

- **What is Electrolytic Cell?**

The electrical current through the electrochemical cell can be initiated in two ways. The first is to connect electrodes with a conductor into a closed electric circuit. By closing the electric circuit it is possible to spontaneously induce electrode reactions on both phases of the metal/electrolyte. In addition, the energy of the current is released at the expense of the energy of a spontaneous chemical reaction. A cell that works this way is called a galvanic cell.

This was explained above. Another way is to close the electric circuit by serial bonding of an external source of current as opposed to the voltage of the cell, wherein the external voltage is greater than the electromotive force of the cell. It drives the current in opposite direction from the direction of its spontaneous flow through the cell. Because of this, electrodes' reactions in the cell have to be contrary to the direction of their spontaneous flow. Forced processes in an electrochemical cell under the influence of an external source of electrical current are called electrolysis, and the electrochemical cell in such a mode of operation is called an electrolytic cell.

2. DIFFERENCE BETWEEN GALVANIC AND ELECTROLYTIC CELL

Definition of Galvanic and Electrolytic Cell

In galvanic cells there are spontaneous redox processes that allow continuous flow of electrons through the conductor,

whereby the chemical energy is converted into electric. In an electrolytic cell, redox reactions take place under the influence of an external source, where the electricity is converted into a chemical energy. The redox reactions are non-spontaneous.

Technique of Galvanic and Electrolytic Cell

Galvanic cells generate electricity with the aid of chemical reactions. In electrolytic cells, an electric current is used for development of a chemical reaction, utilizing an external source along the way.

Design of Galvanic and Electrolytic Cell

Galvanic cell consists of two different electrodes immersed in solutions of their ions that are separated by a semi-permeable membrane or a salt bridge.

Electrolytic cells consist of an electrolytic container in which two electrodes are connected to a DC source. The electrolyte may be a melt or an aqueous solution of some salt, acid or alkali.

Electrode polarity in Galvanic and Electrolytic Cell

In galvanic cells the anode is the negative and the cathode is the positive electrode. In electrolytic cells, the opposite occurs.

Chemical reaction in Galvanic and Electrolytic Cell

In case of galvanic cell, the oxidation reaction takes place at the anode (negative electrode) where there is a surplus of negative charge. At the cathode, the reduction reaction happens, inducing a positive buildup of charge. In case of electrolytic cell an outside source is used to trigger a reaction. At the negative electrode, the electrons are pushed out of it – so the reduction phase will happen on the negative electrode. On the positive electrode the oxidation phase takes place – and this is the anode.

Fuel cells work like batteries but they do not run down or need recharging. They produce electricity and heat as long as fuel is supplied. In a hydrogen fuel cell, a catalyst at the anode separates hydrogen molecules into protons and electrons, which take different paths to the cathode.

Application of Galvanic and Electrolytic Cell

Galvanic cells are used as a source of electrical current, and are more commonly referred to as batteries or accumulators. Electrolytic cells have different practical uses, some of them being making hydrogen and oxygen gas for commercial and industrial applications, electroplating, extracting pure metals from alloys and so on.

IV. SUMMARY

An electrochemical cell is composed of two half-cells or electrodes whose contact is made via an electrolyte (ionic conductor). Half-cells, if separated, can be joined by a salt bridge (concentrated solution of electrolytes in agar-agar gel). The galvanic cell produces electric current based on a chemical change that occurs spontaneously in it. The electrolytic cell does exactly the opposite: the current results in a chemical change. In order for the cell to be galvanic, spontaneous chemical change must occur in it.

12.8. End unit assessment (Answers)

Learning and assessment standard:

Correctly apply the knowledge of redox reactions to support and develop observations and conclusions about the working of electrochemical and electrolytic cells and their applications.

MULTIPLE CHOICE QUESTIONS

1. (d) To convert chemical energy to electrical energy
2. (d) The electrode where reduction takes place and electrons are gained.
3. (e) All voltaic (galvanic) cells involve the use of electricity to initiate non-spontaneous chemical reactions.
4. (c) Reduction occurs at the zinc electrode as the cell operates.
5. (b) Au, 1.94 V
6. (c) 1.44 V
7. (e) 0.080 V
8. (b) -145 kJ
9. (e) $\sim 10^{-72}$
10. (c) only I

OPEN QUESTIONS

Question 1

- a. Hint: Electrons move from Zn to Ag.
- b. Ag is the cathode.
- c. Cell will stop functioning.
- d. When $E_{\text{cell}} = 0$.
- e. Concentration of Zn^{2+} ions will increase and concentration of Ag^+ ions will decrease
- (f) When $E_{\text{cell}} = 0$ equilibrium is reached and concentration of Zn^{2+} ions and Ag^+ ions will not change.

Question 2

- a. (a) Cell e.m.f.: 1.93 V
(b) Half equation: $\text{Mg} \longrightarrow \text{Mg}^{2+} + 2 \text{e}^{-}$ or use \rightleftharpoons
(c) *Change in e.m.f.:* increases
- b. *Explanation:* Equilibrium displaced to Mg^{2+} or to the left
- c. (d) Cell e.m.f. : -0.84 (V)

Explanation: Fe is giving electrons or forming Fe^{2+} or reaction goes in the reverse direction

Question 3

- (a) (i) *Name:* (standard) hydrogen (electrode) / hydrogen half cell
Role: reference electrode / electrode to which others are compared
- (ii) 0.00(V) / 0 / zero
- (b) (i) $\text{emf} = -0.14 - (-0.25) = +0.11 \text{ V}$
(ii) Electrode D / $\text{Sn}^{2+} / \text{Sn}$ / tin / right hand electrode
(iii) $\text{Ni} + \text{Sn}^{2+} // \text{Ni}^{2+} + \text{Sn}$
- (c) (i) $\text{e.m.f} = -0.44 - (-0.14) = -0.30 \text{ (V)}$ / emf for cell is -ve +ve e.m.f for feasible reaction / tin is a weaker reducing agent thus the reaction would not occur
(ii) \diamond Manganese will decrease in size / disappear / eaten away / dissolves / solution turns (pale) pink
 \diamond Effervescence / bubbles (of colourless gas) / fizzing not gas given off

Reaction likely to occur is $\text{Mn} + 2\text{H}^{+} \longrightarrow \text{Mn}^{2+} + \text{H}_2$ +ve e.m.f. / +1.18 V / Mn is strong reducing agent / has large -ve E^{\ominus}

Question 4

Write the Nernst Equation for 25°C:

$$E = E^{\ominus} - 0.0592/n \times \log Q$$

Calculate E^{\ominus} for the cell:

Write the expression for Q:

$$Q = [\text{Sn}^{2+}] / [\text{Ag}^{+}]^2$$

(concentrations of solids = 1)

Write the Nernst Equation for this example:

$$E = E^{\ominus} - 0.0592/n \times \log([\text{Sn}^{2+}] / [\text{Ag}^{+}]^2)$$

Substitute the values:

$$E^{\ominus} = +0.66 \text{ V}$$

$n = 2$ (2 moles of electrons transferred during the redox reaction)

$$[\text{Sn}^{2+}] = 0.15 \text{ M}$$

$$[\text{Ag}^{+}] = 1.7 \text{ M}$$

$$E = +0.66 - 0.0592/2 \times \log([0.15] / [1.7]^2)$$

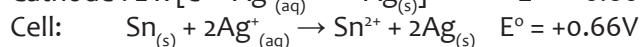
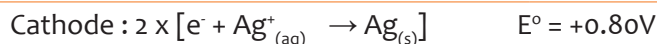
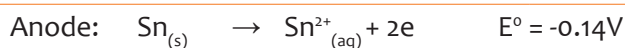

Calculate Q:

$$E = +0.66 - 0.0592/2 \times \log[0.0519]$$

Calculate logQ:

$$E = +0.66 - 0.0592/2 \times -1.285$$

Calculate E:

$$E = +0.66 - 0.0592/2 \times$$

$$-1.285$$

$$\mathbf{E = +0.70V}$$

$E > E^\circ$, and positive, so the cell reaction has a greater tendency to take place at these concentrations.

Question 5

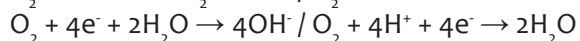
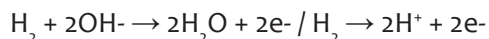

(a) Hydrogen (electrode) produces electrons

Oxygen (electrode) accepts electrons

(b) Hydrogen / the fuel / reactants supplied continuously / fed in

(c) (i) In the fuel cell, a greater proportion of the energy available from the hydrogen-oxygen reaction is converted into useful energy

(ii) Hydrogen is flammable / H^+ corrosive / OH^- corrosive / hydrogen explosive

Question 6

a. Pressure: 101.3 kPa (1.013×10^5 Pa) and Temperature: 25 °C (298 K)

b. Salt Bridge

c. Anode, Mg is a stronger reducing agent than H_2 and therefore (Mg) will be oxidised.



$$\text{e. } E^\circ_{\text{cell}} = E^\circ_{\text{cathode}} - E^\circ_{\text{anode}}$$

$$2.36 = 0.00 - (E^\circ_{\text{anode}})$$

$$E^\circ_{\text{anode}} = -2,36 \text{ V}$$

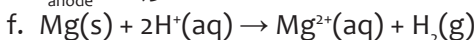

Question 7

- The process in which electrons are lost by a substance.
- Reduction
- $\text{Ag}^+(\text{aq}) + \text{e}^- \rightarrow \text{Ag}(\text{s})$
- Silver (Ag)
- The rate of oxidation (of Ag from the electrode) equals the rate of reduction of Ag^+ from the electrolyte.

Question 8

- Platinum electrode
Hydrogen gas
 $\text{H}^+(\text{aq})$ or HCl or H_2SO_4
298 K, 100 kPa or 1 atm or 1 bar
1 M $[\text{H}^+]$
- (i) 1.61 V
(ii) Positive
- (i) 1.36 V
Left to right
(ii) $\text{Ce}^{4+} + \text{e}^- \rightarrow \text{Ce}^{3+}$
 $\text{V}^{3+} + \text{H}_2\text{O} \rightarrow \text{VO}^{2+} + 2\text{H}^+ + \text{e}^-$
or reversed or $\text{V}^{3+} + 2\text{H}_2\text{O} \rightarrow \text{VO}^{2+} + 4\text{H}^+ + 2\text{e}^-$
- $\text{Ce}^{4+} + \text{V}^{3+} + \text{H}_2\text{O} \rightarrow \text{VO}^{2+} + 2\text{H}^+ + \text{Ce}^{3+}$
or $2\text{Ce}^{4+} + \text{V}^{3+} + 2\text{H}_2\text{O} \rightarrow \text{VO}^{2+} + 4\text{H}^+ + 2\text{Ce}^{3+}$
- (e) $\text{VO}_2^+ \quad \text{VO}^{2+}$

12.9. Additional activities

REMEDIAL QUESTIONS

- Voltage is the measure of _____.
 - The amount of charge per unit of work
 - The number of joules per electron
 - The number of coulombs per joule
 - The amount of work done per group of charge
 - The amount of work per unit energy

2. What is the reduction potential for the half-reaction at 25° C: $\text{Al}^{3+} + 3\text{e}^- \rightarrow \text{Al}$, if $[\text{Al}^{3+}] = 0.10 \text{ M}$ and $E^\circ = -1.66 \text{ V}$?

- a. -1.84 V
- b. -1.60 V
- c. -1.68 V**
- d. -1.66 V
- e. -1.72 V

3. In the standard notation for a voltaic cell, the double vertical line “||” represents:

- a. A phase boundary
- b. Gas electrode
- c. A wire (metal) connection
- d. A salt bridge**
- e. A standard hydrogen electrode

4. The following questions are about this cell: $\text{Al}|\text{Al}^{3+}||\text{Pb}^{2+}|\text{Pb}$

- a. Identify the anode and the cathode.
- b. Write the balanced overall reaction.
- c. Which electrode is inert, Al or Pb?

Answer:

- a. Al is on the left so it is the anode. Pb is the cathode
- b. $2 \text{Al} + 3 \text{Pb}^{2+} \rightarrow 2 \text{Al}^{3+} + 2 \text{Pb}$
- c. Pb because it is not a reactant in the equation.

5. Use the data in the table below, where appropriate, to answer the questions which follow.

	Standard electrode potentials E°/V
$\text{Fe}^{3+}(\text{aq}) + \text{e}^- \longrightarrow \text{Fe}^{2+}(\text{aq})$	+0.77
$\text{Cl}_2(\text{g}) + 2\text{e}^- \longrightarrow 2\text{Cl}^-(\text{aq})$	+1.36
$2\text{BrO}_3^-(\text{aq}) + 12\text{H}^+(\text{aq}) + 10\text{e}^- \longrightarrow \text{Br}_2(\text{aq}) + 6\text{H}_2\text{O}(\text{l})$	+1.52
$\text{O}_3(\text{g}) + 2\text{H}^+(\text{aq}) + 2\text{e}^- \longrightarrow \text{O}_2(\text{g}) + \text{H}_2\text{O}(\text{l})$	+2.08
$\text{F}_2\text{O}(\text{g}) + 2\text{H}^+(\text{aq}) + 4\text{e}^- \longrightarrow 2\text{F}^-(\text{aq}) + \text{H}_2\text{O}(\text{l})$	+2.15

Each of the above can be reversed under suitable conditions.

- a. (i) Identify the most powerful reducing agent in the table.
- (ii) Identify the most powerful oxidising agent in the table.

(iii) Identify all species in the table which can be oxidised in acidic solution by BrO_3^- (aq).

b. The cell represented below was set up.



(i) Deduce the e.m.f. of this cell.

(ii) Write a half-equation for the reaction occurring at the negative electrode when current is taken from this cell.

(iii) Deduce what change in the concentration of $\text{Fe}^{3+}(\text{aq})$ would cause an increase in the e.m.f. of the cell. Explain your answer.

Answer:

a. (i) Fe^{2+}

(ii) F_2/O

(iii) $\text{Fe}^{2+}/\text{Cl}^-$

b. (i) e.m.f. = $E(\text{RHS}) - E(\text{LHS}) = 1.52 - 0.77 = 0.75 \text{ V}$

(ii) $\text{Fe}^{2+} \longrightarrow \text{Fe}^{3+} + \text{e}^-$

(iii) Decrease

Equilibrium (or reaction) shifts to right.

Electrode potential (for $\text{Fe}^{3+}/\text{Fe}^{2+}$) less positive (or decreases)

CONSOLIDATION QUESTIONS

1. The following cell has an EMF of +0.46 V.



Which statement is correct about the operation of the cell?

- Metallic copper is oxidised by Ag^+ ions.
- The silver electrode has a negative polarity.
- The silver electrode gradually dissolves to form Ag^+ ions.
- Electrons flow from the silver electrode to the copper electrode via an external circuit.

2. In an electrolytic cell the electrode at which the electrons enter the solution is called the _____; the chemical change that occurs at this electrode is called _____.

- Anode, oxidation
- Anode, reduction
- Cathode, oxidation
- Cathode, reduction
- Cannot tell unless we know the species being oxidized and reduced.

3. In voltaic cells, such as those diagrammed in your book, the salt bridge _____ .
- is not necessary in order for the cell to work
 - acts as a mechanism to allow mechanical mixing of the solutions
 - allows charge balance to be maintained in the cell**
 - is tightly plugged with firm agar gel through which ions cannot pass
 - drives free electrons from one half-cell to the other

4. An electrochemical cell is shown in the diagram. In this cell, the amount of copper in the electrodes is much greater than the amount of copper ions in the copper sulphate solutions.

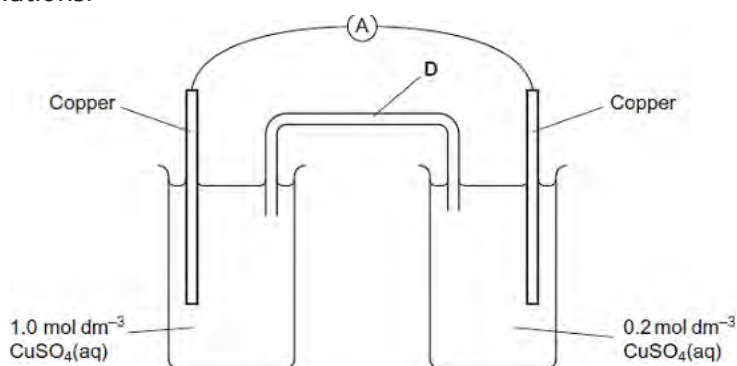

- Explain how the salt bridge **D** provides an electrical connection between the two electrodes.
- Suggest why potassium chloride would **not** be a suitable salt for the salt bridge in this cell.
- In the external circuit of this cell, the electrons flow through the ammeter from right to left.
 - Suggest why the electrons move in this direction.
 - Explain why the current in the external circuit of this cell falls to zero after the cell has operated for some time.
- The simplified electrode reactions in a rechargeable lithium cell are
 Electrode B $\text{Li} + \text{e}^- \longrightarrow \text{Li}$
 Electrode **B**: is the negative electrode.

The e.m.f. of this cell is 2.90 V.

- Use this information to calculate a value for the electrode potential of electrode B.
- Write an equation for the overall reaction that occurs when this lithium cell is being recharged.

- (iii) Suggest why the recharging of a lithium cell may lead to release of carbon dioxide into the atmosphere.

Answer:

- a. It has mobile ions / ions can move through it / free ions.
- b. Chloride ions react with copper ions / Cu^{2+} Or $[\text{CuCl}_4]^{2-}$ formed
- c. (i) The Cu^{2+} ions / CuSO_4 in the left-hand electrode more concentrated.
So the reaction of Cu^{2+} with $2e^-$ will occur (in preference at) left-hand electrode / $\text{Cu} \rightarrow \text{Cu}^{2+} + \text{electrons}$ at right-hand electrode
(ii) (Eventually) the copper ions / CuSO_4 in each electrode will be at the same concentration
- d. (i) -3.05 (V)
(ii) $\text{LiMnO}_2 \rightarrow \text{Li} + \text{MnO}_2$
(iii) Electricity for recharging the cell may come from power stations burning (fossil) fuel (of carbon-containing) fuels.
5. The simplified diagram below shows an electrolytic cell used at an electroplating company to coat iron spoons with silver.

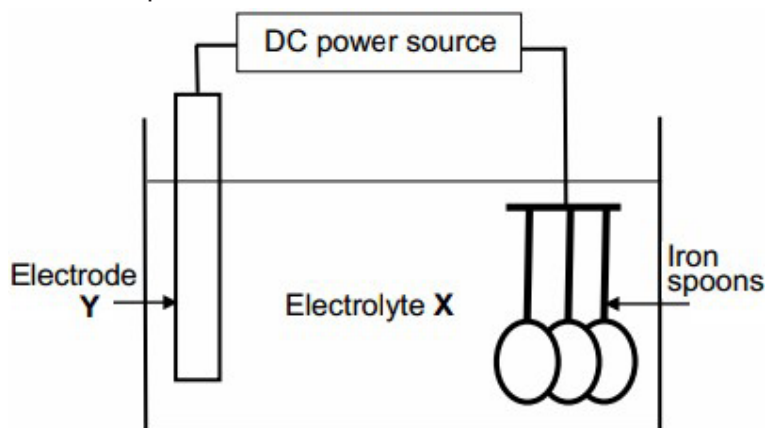

- a. Write down the energy conversion that takes place in this cell.
- b. Direct current (DC) is used in this process. Give a reason why alternating current (AC) is not used.
- c. Which type of reaction (oxidation or reduction) takes place at the spoons?
- d. Write down the:
- (i) Equation for the half-reaction that takes place at electrode Y
(ii) Name or formula of electrolyte X
- e. Give a reason why the concentration of electrolyte X remains constant during electroplating.
- f. Apart from the income generated, write down one major reason why the company electroplates the spoons.

g. Write down the two major expenses for the company during the process.

Answer:

- Electrical energy to chemical energy.
- The polarity of the electrodes must remain constant during plating.
- Reduction
- (i) $\text{Ag(s)} \rightarrow \text{Ag}^+ + \text{e}^-$

(ii) Silver nitrate / AgNO_3
Or Silver ethanoate (silver acetate) / CH_3COOAg
- Rate of oxidation is equal to the rate of reduction.
- Protection
Protects it from rusting (corrosion) OR Appearance/Improve appearance of spoons.
- Cost of electricity
 - Cost of silver

EXTENDED QUESTIONS

1. As the cell given below operates, the strip of silver gains mass (only silver) and the concentration of silver ions in the solution around the silver strip decreases, while the strip of lead loses mass and the concentration of lead increases in the solution around the lead strip. Which of the following represents the reaction that occurs at the negative electrode in the above cell? $\text{Pb} / \text{Pb}(\text{NO}_3)_2 (1.0 \text{ M}) \parallel \text{AgNO}_3 (1.0 \text{ M}) / \text{Ag}$

- $\text{Pb}^{2+} + 2 \text{e}^- \rightarrow \text{Pb}$
- $\text{Pb} \rightarrow \text{Pb}^{2+} + 2 \text{e}^-$
- $\text{Ag}^+ + \text{e}^- \rightarrow \text{Ag}$
- $\text{Ag} \rightarrow \text{Ag}^+ + \text{e}^-$
- none of the above

b. Calculate the potential (in volts) for the voltaic (or galvanic) cell indicated at 25°C .

$\text{Ga} / \text{Ga}^{3+} (10^{-6} \text{ M}) \parallel \text{Ag}^+ (10^{-4} \text{ M}) / \text{Ag}$

2.

- | | |
|------------|------------|
| (a) 1.29 V | (d) 1.21 V |
| (b) 0.97 V | (e) 1.37 V |
| (c) 1.45 V | |

2. Use the data below, where appropriate, to answer the questions which follow.

Standard electrode potentials	E^{\ominus}/V
$2 \text{H}^+(\text{aq}) + 2 \text{e}^- \longrightarrow \text{H}_2(\text{g})$	0.00
$\text{Br}_2(\text{aq}) + 2 \text{e}^- \longrightarrow 2 \text{Br}^-(\text{aq})$	+1.09
$2\text{BrO}_3^-(\text{aq}) + 12 \text{H}^+(\text{aq}) + 10 \text{e}^- \longrightarrow \text{Br}_2(\text{aq}) + 6 \text{H}_2\text{O}(\text{l})$	+1.52

Each of the above can be reversed under suitable conditions.

- State the hydrogen ion concentration and the hydrogen gas pressure when, at 298 K, the potential of the hydrogen electrode is 0.00 V.
- The electrode potential of a hydrogen electrode changes when the hydrogen ion concentration is reduced. Explain, using Le Chatelier's principle, why this change occurs and state how the electrode potential of the hydrogen electrode changes.

A diagram of a cell using platinum electrodes X and Y is shown below.

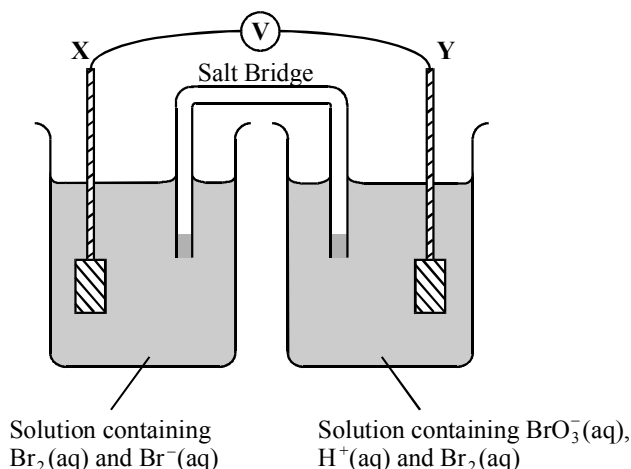

- Use the data above to calculate the e.m.f. of the above cell under standard conditions.
- Write a half-equation for the reaction occurring at electrode X and an overall equation for the cell reaction which occurs when electrodes X and Y are connected.

Answer:

- Hydrogen ion concentration: 1.00 mol dm^{-3}
- Hydrogen gas pressure: 100 kPa
- Explanation of change: Equilibrium displaced to left to reduce constraint
- Change in electrode potential: Becomes negative or decreases/more negative

e. (i) 0.43V

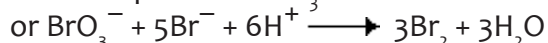
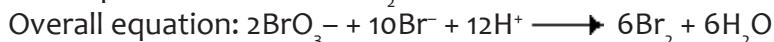
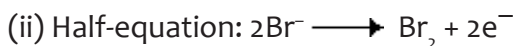

4. The table below shows some values for standard electrode potentials. These data

should be used, where appropriate, to answer the questions that follow concerning the chemistry of copper and iron.

Electrode reaction	E^\ominus / V
$\text{Fe}^{2+}(\text{aq}) + 2\text{e}^- \rightleftharpoons \text{Fe}(\text{s})$	- 0.44
$2\text{H}^+(\text{aq}) + 2\text{e}^- \rightleftharpoons \text{H}_2(\text{g})$	0.00
$\text{Cu}^{2+}(\text{aq}) + 2\text{e}^- \rightleftharpoons \text{Cu}(\text{s})$	+ 0.34
$\text{O}_2(\text{g}) + 2\text{H}_2\text{O}(\text{l}) + 4\text{e}^- \rightleftharpoons 4\text{OH}^-(\text{aq})$	+ 0.40
$\text{NO}_3^-(\text{aq}) + 4\text{H}^+(\text{aq}) + 3\text{e}^- \rightleftharpoons \text{NO}(\text{g}) + 2\text{H}_2\text{O}(\text{l})$	+ 0.96

a. Write an equation to show the reaction that occurs when iron is added to a solution of a copper (II) salt.

b. A similar overall reaction to that shown in (a) would occur if an electrochemical cell was set up between copper and iron electrodes.

(i) Write down the cell diagram to represent the overall reaction in the cell.

(ii) Calculate the e.m.f. of the cell.

c. (i) Use the standard electrode potential data given to explain why copper reacts with dilute nitric acid but has no reaction with dilute hydrochloric acid.

(ii) Write an equation for the reaction between copper and dilute nitric acid.

d. Although iron is a widely used metal, it has a major disadvantage in that it readily corrodes in the presence of oxygen and water. The corrosion is an electrochemical process which occurs on the surface of the iron.

(i) Use the standard electrode potential data given to write an equation for the overall reaction that occurs in the electrochemical cell set up between iron, oxygen and water.

(ii) State, with a reason, whether the iron acts as the anode or cathode of the cell.

(iii) Predict and explain whether or not you would expect a similar corrosion reaction to occur with copper in the presence of oxygen and water.

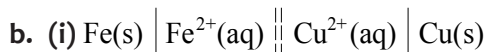
Answer:

(ii) e.m.f. = $+0.34 - (-0.44) = +0.78 \text{ V}$

c. (i) e.m.f for cell must be positive for reaction to occur / be feasible / spontaneous or ΔG must be negative)

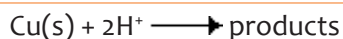

e.m.f = -0.34V will not happen / sensible comparison of the magnitude of E^\ominus for the electrodes, eg 'Cu electrode more positive than hydrogen electrode will not work'

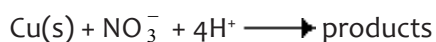

e.m.f = $+0.96 - 0.34 = +0.62\text{V}$ can occur / similar sensible comparison

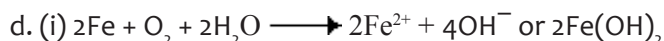
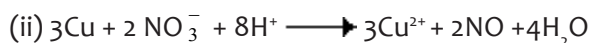

(ii) Anode because Fe loses e^- (negative pole) / oxidation occurs

(iii) e.m.f. = $+0.06 \text{ V}$ or reference to E^\ominus for electrodes

Reasoned argument, e.g. positive should occur / difference so small that reaction unlikely

UNIT 13: FACTORS THAT AFFECT THE RATE OF REACTIONS

13

13.1. Key unit competency:

Explain the factors that affect the rate of chemical reaction and use Arrhenius equation to calculate the ratio of rate constant and activation energy with change in the temperature.

13.2. Prerequisite knowledge and skills

Learners will understand better this unit concerning factors that change the rate of reaction if they know:

- Thermodynamics (studied in senior four unit 18 and in senior five unit 15),
- Factors that affect chemical equilibrium (studied in senior four unit 15).

13.3. Cross-cutting issues to be addressed

Environment and sustainability

The growing awareness of the impact of the human race on the environment has led to recognition of the need to ensure our young people understand the importance of sustainability as they grow up and become responsible for the world around them. Hence Environment and Sustainability is a very important cross-cutting issue

Learners need skills and attitudes that will enable them in their everyday life to address the environment and climate change issue and to have a sustainable livelihood.

While teaching this unit concerning factors that affect the rate of reaction, talk about the environment and its sustainability. For instance, when you talk about the use of catalysts in contact process and Haber process, tell the students that some gases produced during these processes cause air pollution.

13.4. Guidance on the introductory activity:

Before introducing the lesson one of unit 13, you will have to introduce the whole unit. Ask learners (in pairs) to attempt the introductory activity from student's book. This activity intends to relate the unit with learners' daily life and to capture their attention.

Give learners around 10 minutes and ask them to conduct this introductory activity. Learners may not be able to find the right answers but they are invited to predict possible answers.

Select some groups (2-4) to share their findings to the whole class.
After presentation, give your comments.

The expected answers of the introductory activity for unit 13

1.

Slow reactions	Fast reactions
Answer: A and C	Answer: B and D

2. Rusting process takes place if there is water and air (containing oxygen).
3. If the amount of air increases, the speed or rate at which this combustion reaction takes place increases, because air contains high amount of oxygen which is necessary for combustion reaction.
4. Yeast contains enzymes that catalyse the transformation of glucose to ethanol and carbon dioxide.

13.5. List of lessons/sub-heading

	Lesson title	Learning objectives	Number of periods
1	Concept of reaction kinetics	<ul style="list-style-type: none"> • Explain the concept of reaction kinetics. • Appreciate the importance of reaction kinetics. 	2
2	Factors that change the rates of reactions (temperature, concentration, surface area, catalyst, pressure and light).	<ul style="list-style-type: none"> • Explain the effect of different conditions on the rate of reaction. • Carry out experiments to show how different factors affect the rate of chemical reactions • Predict the effect of changing conditions on the rate of reactions • Appreciate the importance of different conditions on the reaction rates. 	4
7	Summative assessment		1

Lesson 1: Concept of reaction kinetic

a. Prerequisites:

Learners will understand better this lesson if they know the concept of chemical reactions.

b. Teaching resources:

- Chemistry textbooks and other relevant chemistry books from the library.
- Where possible use internet
- Distilled water, ethanol, lead (II) nitrate, potassium iodide, nails, test tubes, test tube racks, beakers, droppers, stop watch and match box.

c. Learning activities

This lesson contains one activity:

- Ask learners to form groups of 2-4 (the number of groups and members will depend on your class size and the number of your resources or materials).
- Give learners activity 13.1 (from the student's book)
- As facilitator, move around the class and check if all learners are working.
- Ask learners to present their findings.
- During the presentation ask some questions that lead to lesson objectives.
- Guide learners to make the summary of the lesson themselves.
- Make the final conclusion of the lesson.

Possible answers for activity 13.1

1. - in (a) the reaction is combustion
- in (b) the reaction is precipitation
- in (c) the reaction is redox (oxidation). Corrosion process takes place.
2. Combustion and precipitation are fast reactions while corrosion is slow.
3. For answers of this question refer to the student's textbook.

- After giving final conclusion, assess your learners using checking up 13.1 (from student's book). Learners can do this checking up individually or in pairs. If you do not have enough time in your lesson, give it as individual home work. Make sure you mark the students' work.

Answers for Checking up 13.1

1. Refer to the student's textbook for the concept of reaction kinetics.

2.

$$\text{Rate} = - \frac{\Delta[A]}{\Delta t} = - \frac{(0.4-0.5)}{10-0}$$

$$\text{Rate} = 0.01 \text{ molL}^{-1} \text{ min}^{-1}$$

$$\text{Rate} = 1.66 \times 10^{-4} \text{ molL}^{-1} \text{ s}^{-1}$$

Lesson 2: Factors that change the rates of reactions

a. Prerequisites:

Learners will understand better this lesson if they have understanding on the concept of chemical reaction and thermodynamics.

b. Teaching resources:

- - Chemistry textbooks
- - Where possible use internet
- - Sodium thiosulphate, hydrochloric acid, distilled water, measuring cylinder, stop clock (or stop watch), conical flask and white paper.
- - Hydrogen peroxide, test tubes, wooden splint, manganese (IV) oxide, test tube racks, ammonium iron (II) sulphate crystals or iron (II) sulphate crystals, propane-1,2,3-triol.
- - Sodium chloride, silver nitrate, test tubes.

c. Learning activities

This lesson has four activities: Activity 13.2 (a), Activity 13.2 (b), Activity 13.2 (c) and Activity 13.2 (d).

Activity 13.2 (a)

- Give learners activity 13.2 (a) (from the student's book).
- Ask learners to carry out this activity in pairs
- Move around the class and check if all learners are working.
- Ask learners to present their findings.
- Guide learners to make the summary of the lesson themselves.

Answers for Activity 13.2 (a)

1. For answers of this activity refer to the student's book on factors that affect the rate of reaction.
2. At room temperature, more of the reactants will have the energy necessary to proceed to products (the activation energy) than at the lower temperature of the refrigerator, so the rate of formation of bread mold will be faster. The lower temperature decreases the rate or speed of decomposition of bread.

Activity 13.2 (b)

- Form groups
- Give learners the resources
- Ask learners to carry out the activity 13.2 (b) (from the student's book).
- Ask learners to present their observations and deductions to the whole class.
- Guide learners to make the summary of the lesson themselves.

Possible answers for activity 13.2 (b)

1) The reaction will be fast in the conical flask containing 3cm³ of HCl due to the higher concentration of HCl used.



Activity 13.2 (c)

For this activity use the methodology used in previous activity 13.2 (b).

Possible answers for activity 13.2 (c)

For its answers refer to the student's textbook on the effect of catalyst

Activity 13.2 (d)

For this activity use the methodology used in activity 13.2 (b).

Possible answer for activity 13.2 (d)

The precipitate which is near the strong light will turn black immediately. The light increases the rate or speed of chemical reaction.

Answers for Checking up 13.2

1. For this question refer to the student's book

$$2. \text{Log } \frac{k_2}{k_1} = + \frac{E_a}{2.303R} \left[\frac{1}{T_1} - \frac{1}{T_2} \right]$$

This formula can be written as:

$$\text{Log } \frac{k_2}{k_1} = + \frac{E_a}{2.303R} \left[\frac{1}{T_1} - \frac{1}{T_2} \right]$$

$$\text{Log } \frac{0.07}{0.02} = + \frac{E_a}{2.303 \times 8.314} \left[\frac{1}{700} - \frac{1}{500} \right]$$

From the above expression

$$E_a = 18,230.8 \text{ J}$$

$$\text{Since } k = A e^{\frac{E_a}{RT}} \Rightarrow 0.02 = A e^{\frac{-18,230.8}{8.314 \times 500}} = A e = 1.61$$

3. refer to the method used to solve question(2) above

13.6. Summary of the unit

Chemical kinetics is a branch of chemistry mainly dealing with the rates of reaction. Chemical kinetics studies not only help us to determine the speed or rate of a chemical reaction but also describe the conditions by which the reaction rates can be altered. The factors such as concentration, temperature, pressure, and catalyst, light and surface area affect the rate of a reaction. This unit deals with factors that affect the rate of chemical reactions. When we say “chemical kinetics”, we mean that we are studying the rates of reaction and factors that affect the rates.

A chemical reaction occurs when the molecules of the reactants collide with one another in the reacting environment. The rate at which a reaction occurs depends on the rate of the collision of the molecules, and the collision rate depends on various factors, which can be altered to change the rate of a reaction. The reaction rate can be increased by the action of one or more of the factors:

1) Concentration: The rates of many reactions depend on the concentrations of the reactants. Increasing the concentration of one or more reactants will normally increase the reaction rate.

2) Pressure: When the pressure increases in the gaseous system, the number of collisions between reactants also increases. Consequently the rate of reaction is increased. At high pressure, the gas particles are closer together which can increase the collision.

3) Temperature: For most chemical reactions, temperature is directly proportional to the rate of the chemical reaction. The increase in temperature increases the energy of the reactant molecules, making them move faster and more susceptible to collisions, thereby increasing the reaction rate.

4) Surface Area of the Reactants: For the same mass, many small particles have a greater surface area than one large particle. The more surface contact between reactants, the higher the rate of reaction. The less surface contact, the lower the reaction rate. The rate of chemical reactions increases by increasing the surface area of reactants. For example, powdered sugar dissolves more quickly in water than a lump of sugar.

5) Catalyst (Positive catalyst): is a substance that increases the rate of a chemical reaction by lowering the activation energy without itself being consumed by the reaction. Catalysts reduce the amount of energy required to break and form bonds during a chemical reaction. When the reaction is complete, catalysts remain chemically unchanged and they can be reused several times.

6) Light: is a form of energy that can affect the rate of a reaction. The rate of some photochemical reactions increases with increase in the intensity of suitable light

With the increase in the intensity, the number of photons in light also increases. Hence more number of reactant molecules gets energy by absorbing more number of photons and undergo chemical change.

Knowing and controlling the rate of reactions is important in living cells and industry. In the body, chemical reactions must take place at the correct rate to supply your cells with exactly what they need when they need it. The products of chemical reactions make money so it is important to be able to speed up the rate and make them as cheaply as possible.

13.7. Additional Information

THEORIES OF CATALYSIS

Catalysis can be explained using the two theories:

- Intermediate compound formation theory
- Adsorption theory

a. The intermediate compound formation theory

In general, the intermediate compound formation theory applies to homogeneous catalyst reactions. According to this theory, the catalyst forms an intermediate with one of the reactants. But the intermediate compound is unstable so that the intermediate compound combines with other reactant to form the desired product and the catalyst is regenerated.

Example:

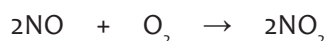

(catalyst) (Intermediate compound)

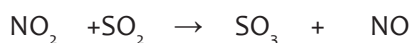

(product) (catalyst)

b. Adsorption Theory

In general adsorption theory applies to heterogeneous catalytic reactions. The catalyst functions by the adsorption of the reacting molecules on its surface.



The adsorption reaction undergoes four types of steps:

(i) Adsorption of reactant molecule:

The reactant molecules A and B strike the surface of the catalyst. The reaction molecules held up by the partial chemical bond.

(ii) Formation of intermediate complex:

The reactant molecule adjacent one another join to form an intermediate complex (A-B). The intermediate complex is unstable.

(iii) Decomposition of intermediate complex:

The intermediate complex breaks to form the products C and D. The product molecules hold to the catalyst surface by partial chemical bond.

(iv) Release of product:

The product particles are released from the surface.

13.8. End unit assessment Answers

Learning and assessment standards:

Collaborate with others to conduct experiments to investigate the factors that affect the rate of chemical reaction, resolving differences and agreeing ways forward.

1. B) reaction kinetics
2. B) reactant molecules collide more frequently and with greater energy per collision
3. C) time
4. A) concentration
5. D) All above
6. A) activation energy
7. D) adding a catalyst for the reaction
8. D) Oxygen
9. D) increasing the volume of the container
10. B) doubled

11. Aluminium powder reacts vigorously because of the particle size (surface area). If aluminium is converted into powder the surface area increases, therefore, increasing the surface area of the metal by converting it powder, its reaction rate increases.

12. Refer to the student's book.

$$13 \text{ Rate} = -\frac{1}{2} \frac{\Delta[\text{N}_2\text{O}_5]}{\Delta t} = -\frac{1}{2} \left[\frac{(2.08-2.33) \text{ molL}^{-1}}{184\text{min}} \right]$$

$$\text{Rate} = 6.79 \times 10^{-4} \text{ molL}^{-1} \text{ min}^{-1}$$

$$\text{Rate} = (6.79 \times 10^{-4} \text{ molL}^{-1} \text{ min}^{-1}) / (60\text{min}/1\text{h}) = 4.07 \times 10^{-2} \text{ molL}^{-1}/\text{h}$$

Rate = $(6.79 \times 10^{-4} \text{ mol L}^{-1} \text{ min}^{-1}) / (1 \text{ min} / 60 \text{ s}) = 1.13 \times 10^{-5} \text{ mol L}^{-1} \text{ s}^{-1}$
 $3145 \text{ J K}^{-1} \text{ mol}^{-1}$.

Rate = $\frac{1}{4} \frac{\Delta[\text{N}_2]}{\Delta t} = 6.79 \times 10^{-4} \text{ mol L}^{-1} \text{ min}^{-1} \times 4 = 2.72 \times 10^{-3} \text{ mol L}^{-1} \text{ min}^{-1}$ or $1.63 \times 10^{-1} \text{ mol L}^{-1} \text{ s}^{-1}$

The rate of production of nitrogen dioxide is:

or

14. Calculate the activation energy for a reaction whose rate constants are $2.15 \times 10^{-1} \text{ dm}^3 \text{ mol}^{-1} \text{ s}^{-1}$ and $7.25 \times 10^{-3} \text{ dm}^3 \text{ mol}^{-1} \text{ s}^{-1}$ at 991K and 500K respectively. (R=8.

Answer:

$$15. \text{Log} \frac{k_2}{k_1} = + \frac{E_a}{2.303R} \left[\frac{1}{T_1} - \frac{1}{T_2} \right]$$

$$\text{Log} \frac{k_2}{k_1} = + \frac{190 \times 10^3}{2.303 \times 8.3145} \left[\frac{1}{550} - \frac{1}{781} \right]$$

$$\frac{k_2}{k_1} = 2 \times 10^5$$

It means that, if the temperature increases, the rate constant also increases.

13.9. Additional activities

• Remedial Activities:

1. How does the temperature of the reactants affect the reaction rate?

- Temperature has no effect on the reaction rate.
- Reaction rate decreases with increase in temperature.
- It is unpredictable.
- Reaction rate increases with increase in temperature.

Answer: D

2. Which of the following is true about the rate of reaction?

- The greater the particle size, the greater will be the reaction rate.
- Addition of a catalyst decreases the rate of reaction.
- Increase in temperature will increase the rate of reaction.
- Agitation decreases the rate of reaction.

Answer: C

3. Which of the following will not increase the rate of reaction?

- Maintaining constant temperature of the reaction mixture
- Addition of a catalyst to the reaction mixture
- Addition of more reactants to the reaction mixture
- Shaking the vessel containing the reaction mixture

Answer: A

4. Sulphur trioxide reacts with water to form sulphuric acid according to the equation given below.

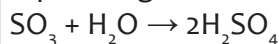

At the start of the reaction, there was no acid or $[\text{H}^+] = 0$. After 50 seconds, $[\text{H}^+] = 7.5 \times 10^{-6} \text{ M}$. What is the rate of the reaction?

- $1.5 \times 10^7 \text{ M/s}$
- $1.5 \times 10^{-7} \text{ M/s}$
- $3.0 \times 10^{-7} \text{ M/s}$
- $8.0 \times 10^5 \text{ M/s}$

Answer: B

5. By use of appropriate examples in each case show what you understand by:

- Homogeneous catalysis
- Heterogeneous catalysis

Answer: refer to the student's book

☐ Consolidation activities:

- What does the rate of reaction tell us?
- State six main factors that affect the rate of reaction?
- What is activation energy?
- What effect does increasing temperature have on the rate of reaction?
- Why does temperature increase the rate of reaction?

Answers: refer to the student's book for answers of these consolidation activities

☐ Extended activities:

- What effect does increasing concentration have on the rate of reaction?
- Why does an increase in concentration increase the rate of reaction?
- Explain why increasing the pressure in gases increases their rate of reaction?
- What effect does increasing the surface area of reactants have on the rate of reaction?
- Explain why increasing surface area increases the rate of reaction.
- What effect does adding a catalyst have on the rate of reaction?
- What happens to a catalyst during the reaction?
- Why does a catalyst increase the rate of reaction?
- Why does a catalyst increase the rate of reaction?
- Can a substance that is a catalyst be used to speed up any reaction?

Answers: refer to the student's book extended activities

UNIT 14: RATE LAWS AND MEASUREMENTS

14

14.1. Key unit competency:

Measure the rates of reaction and formulate simple rate equations using the experimental results.

14.2. Prerequisite (knowledge, skills, attitudes and values)

Students will learn better the rate laws and measurements if they have a good understanding on: Laboratory safety and apparatus (covered in senior 1), air composition and pollution (covered in senior 1).

Energy changes and energy profile diagrams for chemical reactions (covered in senior four), enthalpy change of reactions (covered in senior five), Trends in chemical properties of elements (covered in senior four and senior six). Organic chemistry especially about halogenoalkanes (covered in senior five), Nomenclature of inorganic and organic compounds (covered from senior one to senior five). Integration and other skills about calculus.

14.3. Cross-cutting issues to be addressed

- **Environment and sustainability**

Reaction kinetics explains different processes: Those occurring in nature and those occurring due to man activities like in industries. Some of the substances produced in these phenomena destroy the environment. Here we have to emphasize on environmental effects caused by industries (by human activity).

- Sulphur dioxide (SO_2) produces during the manufacture of sulphuric acid can cause acid rain.
- N_2O which is a greenhouse gas.
- NO and NO_2 respectively participates in the destruction of ozone layer

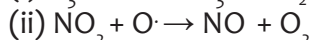
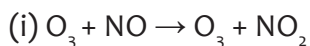

The equation (ii) above shows how NO_2 participates in the chain reaction leading to the deterioration of ozone layer, when it reacts with oxygen free radical created by CFCs (See Senior five organic chemistry).

- NO and NO_2 also involve in the formation of acid rain.

- **Standardisation Culture**

- The knowledge about how radiations are spread in the atmosphere by different activities (for example those producing radiations (Alpha, beta, gamma) is necessary in order to prevent from their effect).
- Kinetics of reactions can explain why chemical fertilisers have to be in form of coated pellets so that there is a controlled release in nutrients. This can reduce the disadvantages of using fertilisers.
- Kinetics of reactions explains why cars and other activities that produce gases which are pollutants in addition to other techniques they use to reduce **pollution**, should use catalytic converters in to convert harmful substances into substances which are not harmful or which are less harmful.

Example: In the exhaust of a car when gasoline is burnt some pollutants are emitted:

CO, NO, and hydrocarbons.

CO (also called silent killer): It kills people by asphyxia.

The purpose of a catalytic converter is to lower the activation energy for reactions that convert pollutants into substances such as CO₂, N₂, O₂ and H₂O, which are already in atmosphere.

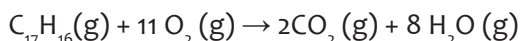
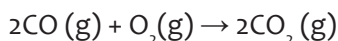

The additive lead tetra ethyl was added in petrol in order to increase the octane number or octane rating of gasoline but today, unleaded petrol(or gasoline) is used because lead poisons the catalytic converters in vehicles and therefore it reduces the ability of the Pt and Pd in the catalytic converters to react with catalysts.

- **Financial Education**

Financial education has a key role of not only improving knowledge of personal but also transforming this knowledge into action. In this unit, students must acquire knowledge/ attitudes and values about increasing productivity and increase the income in factories they will be working for after their studies, or the small enterprises they may create on their own.

14.4. Guidance on the introductory activity

Introductory activity for unit 14, student's book

Kinetics of reactions is not new for students because in unit 13 they learned it about the factors that affect the rate of reactions.

Students also know some phenomena which are caused/created by man and others which are natural in which rate of reaction is involved. Therefore, the introduction of this unit to students of senior six would be simple. The introductory activity can attract interest of students as it is built on the processes that can be observed/ explained clearly and some of them have been seen in the previous classes. Here is a guide of how this activity can be performed by students guided by the teacher.

- Put your students in groups of 3-4 students.
- Provide students with worksheets with the colored pictures (or use a projector) with the introductory activity, unit 1 from student's book S6.
- Give them 15 minutes to read, analyze, interpret and discuss the activity and answer the questions asked about them. Let them this book, other books or search from internet in order search what they don't discover directly.
- Call two groups to present their findings. You may note some key points at this stage.
- Ask other members to comment on the findings of other groups.
- Guide learners to make a conclusion. Here you can add missing information on their findings.

The expected answers to the introductory activities are:

1. Explosion

2. *Weathering*: is the breaking down of rocks, soil, and minerals as well as wood and artificial materials through contact with the Earth's atmosphere, water, and biological organisms.

3. Fireworks: device containing gunpowder and other combustible chemicals which causes spectacular effects and explosions when ignited (firework display), used for display or in celebrations. They are composed of:

Chemical ingredients of fireworks are chosen to produce specific colors. Barium compounds produce green colors when heated, copper salts produce green and blue flames, sodium salts are yellow in flame, lithium compounds produce red colors, magnesium metal produces brilliant white light when burned, and strontium compounds produce brilliant red colors. Salts used contain both metallic cations and nonmetallic **anions**. Anions such as chlorates, perchlorates, and nitrates also contribute **oxidizing** power to the chemical mixture.

4. Formation of petroleum

5. Experimental set-up of HCl-Magnesium reaction: Laboratory preparation of hydrogen.

6. Precipitation reaction:

It(that producing a yellow precipitate as in the figure)can result from either one of these reactions:

- Reaction between silver ions with iodide ions
- Reaction of lead(II) ions with iodide ions

II.

Fast processes	Explosion	fireworks	Precipitation reaction	Reaction between magnesium and HCl
Slow processes	Weathering of rocks	Formation of petroleum		

14.5. List of lessons/sub-heading

#	Lesson title	Learning objectives (from the syllabus including knowledge, skills and attitudes):	Number of periods
1	Theories of reaction rates	<ul style="list-style-type: none"> • State and explain kinetic conditions for a chemical reaction to take place. • Explain the effect of the temperature and catalysts on the rate of the reaction using Boltzmann distribution of energies (and of collision frequency). • Differentiate between SN₁ and SN₂ mechanisms. • Interpret the graphs which show the change in activation energy • use collision theory to predict if the reaction will go faster or slower. • Appreciate the contributions of Arrhenius and Boltzmann on the effect temperature and activation energy of different substances and number of molecules. 	4
2	Measuring the rates of reaction	<p>Perform practical activities to measure the rates of reaction by observing the changes in physical quantities (e.g. volume, mass</p> <p>Develop a spirit of team work, analysis, and self-confidence while discussing exercises and performing the experiments.</p>	3

3	Experimental determination of orders of reactions and rate laws	<ul style="list-style-type: none"> • Deduce the order of reaction from appropriate experimental data. • Calculate the initial rates and the rate constants of reactions from the experimental data. • Perform practical activities to show how different reactions have different rates. • Construct rate equations of the form $(\text{Rate} = k[A]^n[B]^m)$ limited to simple cases involving zero, first and second order reactions. 	5
4	Relation between reactant concentrations and time for zero order reaction,	<ul style="list-style-type: none"> • Interpret graphs of concentration against time and those of concentration against rate for zero and first order reactions. 	3
5	Difference between order of reaction and molecularity	Differentiate between order of reaction and molecularity	2
6	Reaction mechanisms and kinetics	-State and explain the rate determining the steps for multi-step reactions.	4
Assessment			2

Lesson 1: Theories of reaction rates

This is the first lesson of unit 14 and it has four periods. The first lesson also covers the introduction of the whole unit.

a. Prerequisites/Revision/Introduction:

Students will learn better this lesson if they have knowledge about heat changes in chemical reactions, organic chemistry especially about chemical reactions of halogenoalkanes.

b. Teaching resources:

Books, projectors, simulations, chalkboard, chalk, computer.

c. Learning activities

Before introducing the lesson, you will have to introduce the whole unit. Let learners therefore attempt the introductory *activity which* leads students to the first lesson of the unit.

Methodological steps:

As a guide, you are expected to guide students to learn by doing activity 14.1 as described below:

Activity 14.1

For Activity (14.1.1), student's book S6,

- Invite four students on the chalkboard in order to answer the question 14.1 (a) and 14.1 (b): 2 students for (a) and another two students for (b) on the chalkboard.
- Tell other students to comment on the answers given by other groups. In this activity the learner who gives a comment should also use it to correct the figures given by other groups.

The expected answers to the activity 14.1.1.a and 14.1.1.b are:

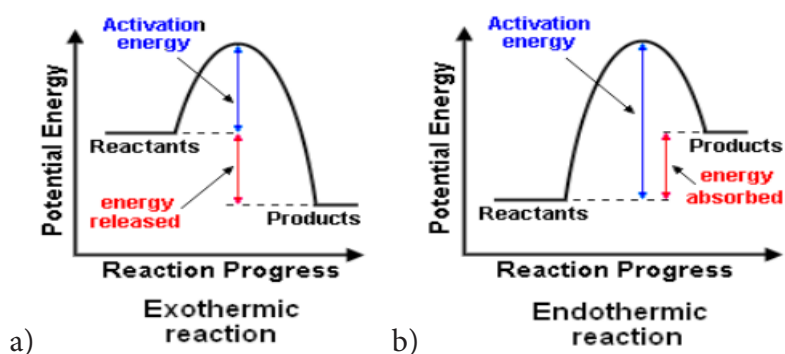

For activity (14.1.2), student's book S6,

- Put your students in groups of 3 to 4
- Give the activity (14.1.2.) to students (containing instructions)
- Give to students this book or other relevant resources
- Invite representatives of groups to presents their group findings (four presentations).
- Ask students to comment on evaluate the findings presented by their fellows
- Ask some questions to assess achievement of instructional objectives (each student works individually). Avoid intervening directly on the questions above and during the presentation learners should use the summary they took in their summary book and not directly use other content sources (books or notebooks)
- From the findings of students you can help students to summarise and to find important conclusions about collision theory of reaction rates

Checking up 14.1

1. The expected answers to the checking up 14.1 (a) and (b) are:

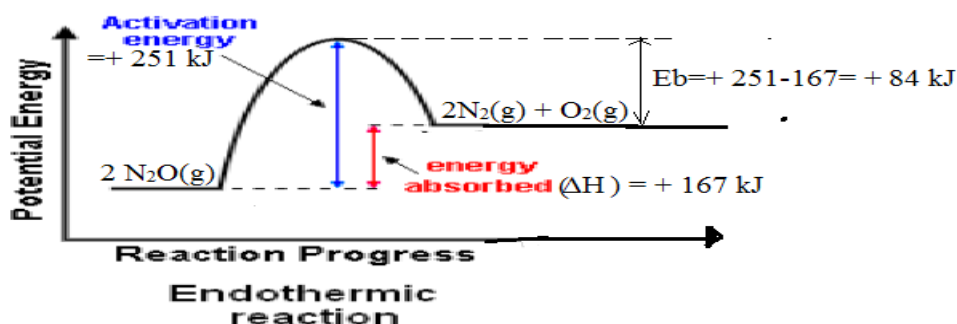

E_b is the activation energy for the reverse reaction (for products to give reactants)

2. The expected answers to the checking up 14.1 (a) and (b) are:

For the reaction between A-A and B-B to give AB + AB

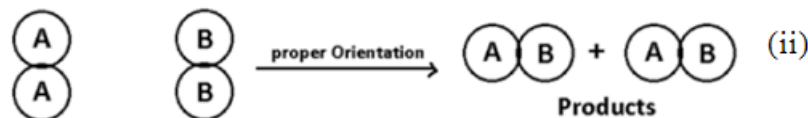
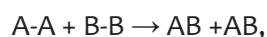

For the situation in (i) the molecules do not collide with sufficient kinetic energy or don't collide with proper orientation or both therefore no products are formed

For the situation in (ii) the molecules have sufficient kinetic energy and collide with proper orientation and therefore the products are formed.

Lesson 2: Measuring the rates of reaction

a. Prerequisites knowledge, skills, and attitudes and values:

Students will learn better this lesson if they have knowledge about periodic table, Laboratory safety and apparatus (covered in senior 1), Air composition and pollution (covered in senior 1)

b. Teaching resources:

Books, projectors, simulations, chalkboard, chalk. Conical flask, Sodium thiosulphate, hydrochloric acid, marble, manganese dioxide, magnesium, internet.

c. Learning activities

You can start by asking your students questions about the rate of reactions

Methodological steps:

As a guide, you are expected to guide students to learn by doing activity 14.1 as described below:

Activity 14.2. 1 and 14.2. 2

- Take your time before the time for the experiment so that you prepare the products, arrange the apparatus appropriately, and perform the experiment following the procedure provided in student's book.
- The time of experiment:
 - Form groups of 4 students
 - Give to each group a worksheet (or you might have written the experiment on the chalkboard)
 - Tell students to use 10 minutes to read the worksheet and check the availability of all materials in the experiment as indicated in the procedure on the worksheet.
 - Give the feedback to students on the same day, because students still remember well what they did.
- a. For drawing an appropriate graph:
 - Select an appropriate scale which will ensure that the graph occupies more than half the page. Plot the points accurately.
 - Join the points using a smooth curve.
 - Draw a tangents to the curve at $t = 10$ s.

Each experiment has to be done in two hours including the feedback.

The expected answers for the activity 14.2.1 **Experiment 1**(Measuring the rate of reaction by observing the volume change of the gas produced) are:

a.

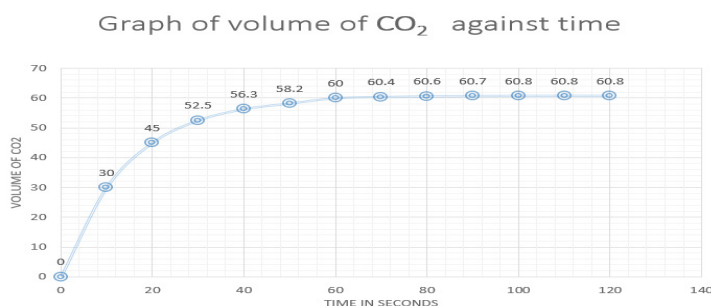

From figure, considering the curves for 3.0 M hydrochloric acid:

At time =10 seconds

$$\Delta V = 71 - 20 \text{ cm}^3 = 51 \text{ cm}^3$$

$$\Delta t = 30 - 5 \text{ cm}^3 = 25 \text{ cm}^3$$

$$\Delta t = 25 \text{ cm}^3$$

b. The rate of evolution of CO_2 at time = 10 seconds is = $\frac{\Delta V}{\Delta t} = \frac{51}{25} = 2.04 \text{ cm}^3 \text{ s}^{-2}$

The expected answer for the activity 14.2.1 Experiment 2 as the rate of evolution of carbon(IV) oxide at time = 20 seconds:

$$\frac{\Delta V}{\Delta t} = \frac{42}{47} = 0.894 \text{ cm}^3$$

c. At time = 100 seconds

The line obtained is a straight horizontal.

$$\Delta V = 0$$

$\Delta t = \text{is very large (Infinity)}$

The rate of evolution = $100 \text{ cm}^3 \text{ s}^{-2}$

The reaction has stopped

The expected answers for experiment 14.2.2 (Experiment 2: Measuring the rate of reaction by observing color change), are :

b) (i) The equation between $\text{Na}_2\text{S}_2\text{O}_3(\text{aq})$ and $\text{HCl}(\text{aq})$,

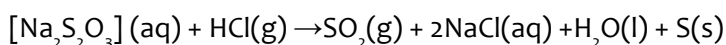

In the reaction above the color changed from colorless to yellow.

(ii) Table of results:

Volume of $\text{Na}_2\text{S}_2\text{O}_3 / \text{cm}^3$	Volume of $\text{H}_2\text{O} / \text{cm}^3$	Volume of HCl / cm^3	[$\text{Na}_2\text{S}_2\text{O}_3$] * 10^{-3}	time/sec for the cross to disappear	ΔC * 10^{-3}	Δt	$\frac{\Delta C}{\Delta t}$ * 10^{-3}
100	0	25	93	74	93 - 46.5 =	100 - 74 = 26	$\frac{47 *}{26} = 1.81$
50	50	25	46.5	100	46.5		
50	50	25	46.5	100	46.5	143 - 100 = 43	$\frac{2323}{4343} = 0.53488$
25	75	25	23	143	-23 = 23		
25	75	25	23	143	23 -	249 - 143 = 106	$\frac{11.411.4}{106 \ 106} = 0.1075$
12.5	87.5	25	11.6	249	11.6 = 11.4		

(iii) A graph of time for the cross to disappear against volume of $\text{Na}_2\text{S}_2\text{O}_3(\text{aq})$

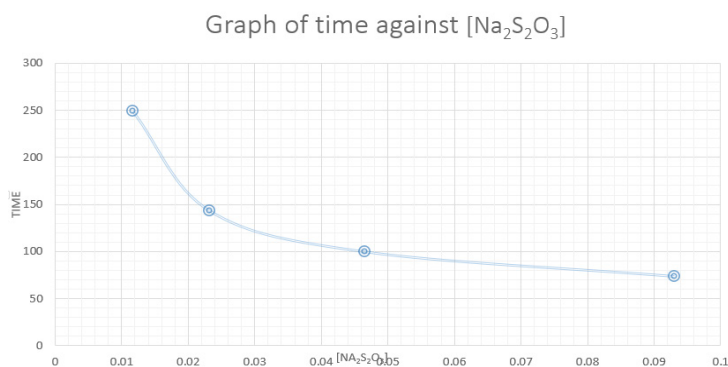

(iv) The chemical test of a gas produced in the reaction:

Reaction with acidified KMnO_4 and acidified $\text{K}_2\text{Cr}_2\text{O}_7$:

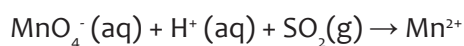

violet

Colourless

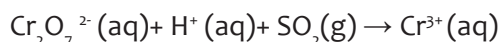

Orange

Green

Checking up 14.2

The expected answers to the activity 14.2.1. are

a. The environmental effects of the gas produced in the reaction of $\text{Na}_2\text{S}_2\text{O}_3$ with HCl.

The equation: $\text{Na}_2\text{S}_2\text{O}_3 (\text{aq}) + \text{HCl}(\text{g}) \rightarrow \text{SO}_2(\text{g}) + 2\text{NaCl}(\text{aq}) + \text{H}_2\text{O}(\text{l}) + \text{S}(\text{s})$

The gas produced is sulphur dioxide (SO_2):

– SO_2 causes acid rain by the following equation: $\text{SO}_2(\text{g}) + \text{H}_2\text{O}(\text{g}) \rightarrow \text{H}_2\text{SO}_3(\text{g})$

Acid rain:

- causes deforestation
- acidifies water ways to the detriment of aquatic life
- corrodes building materials and paints.
 - Sulphur dioxide affects the respiratory system, particularly lung function, and can irritate the eyes.
 - Sulphur dioxide irritates the respiratory tract and increases the risk of tract infections. It causes coughing, mucus secretion and aggravates conditions such as asthma and chronic bronchitis

b. The ejection of that gas in the environment can be reduced by recycling: Using it to produce sulphuric acid by contact process?

2. The expected answers to the activity 14.2.2. are

Other reactions that produce gas:

- Reaction between zinc and dilute hydrochloric acid
- Reaction between ethanol and sodium (*hydrogen gas is emitted*) (*hydrogen gas is emitted*)
- Reaction between group 1 metals and hydrochloric acid (Explosive reaction because the reaction is very exothermic, the hydrogen gas formed is ignited by the heat produced).

Lesson 3: Experimental determination of orders of reactions and rate laws

a. Prerequisites/Revision/Introduction:

Students will learn better this lesson if they have knowledge about operations like addition, division, multiplication.

b. Teaching resources:

Books, projectors, chalkboard, chalk, internet.

c. Learning activities

You can start by asking your students questions mathematics which are related to the lesson.

Methodological steps:

As a guide, you are expected to guide students to learn by doing activity 14.3 as described below:

Activity 14.3

For activity (14.3), student's book S6,

- Put your students in groups of 4
- Give to students this book or any other relevant resources.
- Give 15 minutes to your students in order to read and analyse the content about experimental determination of orders of reaction and rate laws.
- Invite three members from any three groups to present the findings of their groups.
- Ask members of other groups to give their comments on the presentations.
- Based on learners' work, guide them to draw important conclusion.

Checking up 14.3

(i) Order with respect to A : in experiments 1 and 2, When the concentration of A doubles ,while keeping that of B constant ,rate doubles ,which shows that order with respect to A=1

Order with respect to B : in experiments 1 and 3 ,when the concentration of B is doubled while keeping that of A constant ,rate doubles ,which shows that order with respect to B=1.

(ii) Rate = k [A][B]

$k = \frac{[Rate]}{[A][B]}$, and using results of experiment 1 (or any other set of results)

$$k = \frac{2.1 \text{ mol dm}^{-3} \text{ s}^{-1}}{1.00 \times 10^{-2} \text{ mol dm}^{-3} \times 2.80 \times 10^{-3} \text{ mol dm}^{-3}}$$

$$= 7.50 \times 10^4 \text{ mol}^{-1} \text{ dm}^3 \text{ s}^{-1}$$

(iv) Rate = $7.50 \times 10^4 \times 8.50 \times 10^{-3} \times 3.83 \times 10^{-3} = 2.44 \text{ mol dm}^{-3} \text{ s}^{-1}$

The order will change from 2 to 1 . Since B was in large excess, its concentration would be taken to be constant during the reaction and the rate would depend on concentration of A only.

Lesson 4: Relation between reactant concentrations and time for zero order reaction

a. Prerequisites/Revision/Introduction:

Students will learn better this lesson if they have knowledge periodic table and chemical reactions, integration, drawing graphs, internet.

b. Teaching resources:

Books, projectors, graph papers, pencils, chalkboard, chalk.

c. Learning activities

You can start by asking your students questions concentration and time as applied to kinetics of reaction.

Methodological steps:

As a guide, you are expected to guide students to learn by doing activity 14.4 as described below:

Activity 14.4

For the activity 14.4.1 ,student's book S6,

- Give the activity (14.4.1.) to learners (individual work)
- Give 10 minutes to complete the activity
- Tell the learners to exchange their findings in pairs and give another 4 minutes for discussing their findings in pairs.
- Tell any two members of from any two pairs to come and write their findings on the board at the same time.

- Tell other pairs to comment on what other pairs have written and help learners to draw important conclusions about the experimental determination of the rate laws.

The expected answers for **activity 14.4.1**

a. Average rate of reaction in terms of A and B $= \frac{-\Delta[A]}{\Delta t} = +\frac{\Delta[B]}{\Delta t}$

Where: $\frac{-\Delta[A]}{\Delta t}$ is the average rate of appearance of reactant A, and $\frac{+\Delta[B]}{\Delta t}$

b. Rate law for the reaction, Rate = $k[A]^n$

c. Comparing the equation found in (a) in terms of A only and the equation found in (b) we get,

$$\frac{\Delta[A]}{\Delta t} = k[A]^n$$

For activity 14.4.2

- Give this activity to students as an individual work to do during prep.
- Tell any two learners to present their findings one by one.
- Let learners comment on the findings of their fellows and help them to make a conclusion.

Answers for activity 14.4. 2: Refer to students' book

Checking-up 14.4

1.

$$\text{Answer } \ln[A]_0 - \ln[A]_t = kt$$

$$t_{1/2} = 2.5 \text{ min} \times 60 \text{ sec/min} = 150 \text{ sec}$$

$$[A]_t = 10\% = 0.1$$

$$k = \frac{0.693}{150} = 4.62 \times 10^{-3} \text{ sec}^{-1}$$

$$[A]_t = 100\% = 1$$

$$\ln 1 - \ln 0.1 = 4.62 \times 10^{-3} \text{ s}$$

$$t = \frac{\ln 0.1}{4.62 \times 10^{-3}} \text{ sec} = 498.39 \text{ sec}$$

2. See students' book

Lesson 5: Difference between order of reaction and molecularity

a. Prerequisites/Revision/Introduction:

Students will learn better this lesson if they have knowledge about periodic table

and chemical reactions, counting skills, kinetics of reaction about experimental determination of order of reactions.

b. Teaching resources:

Books, projectors, internet, chalkboard, chalk, internet, computer.

c. Learning activities

You can start by asking your students questions about chemical reactions.

Methodological steps:

As a guide, you are expected to guide students to learn by doing activity 14.5 as described below:

Activity 14.5

For activity 14.5

- Give this activity to students as a homework in groups.
- Tell any two members of any two groups to present the findings of their groups. one group after another.
- Let learners comment on the findings of their fellows and help them to make a conclusion about the difference between order of reaction and molecularity of a reaction.

The expected answers for experiment 14.5

Answers for activity 14.5: Refer to student's book

Checking-up 14.5

The molecularity of each elementary reaction depends on the number of reaction molecules in equation for the reaction. The overall equation is the sum of the equations for the elementary reactions. The intermediate is a substance formed in one step of the mechanism and used in another and therefore not part of the equation for the overall reaction.

(a) The first elementary reaction involves a single reactant and is consequently unimolecular.

The second reaction, in which involves two reactant molecules, is bimolecular.

(b) Adding the two elementary reactions gives

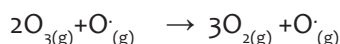

Because O (g) appears in equal amounts on both sides of equation, it can be eliminated to give the net equation for the chemical process.

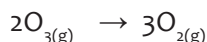

(c) The intermediate is $O_{(g)}$. It is neither an original reactant nor a final product, but is formed in the first step of the mechanism and consumed in second.

Lesson 6: Reaction mechanisms and kinetics

a. Prerequisites/Revision/Introduction:

Students will learn better this lesson if they have knowledge about periodic table and chemical reactions, organic chemistry especially about chemical reactions of halogenoalkanes, kinetics about difference between order of reaction and molecularity of reaction.

b. Teaching resources:

Books, projectors, simulations, chalkboard, chalk, internet.

c. Learning activities

You can start by asking your students questions about chemical reactions.

Methodological steps:

As a guide, you are expected to guide students to learn by doing activity 14.6 as described below:

Activity 14.6

Activity 14.6.1.a & b

- Ask questions in activity 14.6.1 (a) &(b) orally
- Let learners express their views and guide learners to find important conclusions.

The expected answers for activity 14.6.1 (a) &(b)

a. Those people have to be organized in such way that those who are slow are put in front. Therefore the speed of the fast people must depend on the speed of the slow people.

b. Difference between elementary reaction and complex reaction

Elementary reaction	Complex reaction
Occurs in one step	Occurs in many step
Rate law of elementary reaction is determined directly from its molecularity	The slowest step is the rate determining step and thus is used to determine the rate law.

For activity 14.6.2

- Put your students in groups of 3-4 (or even 5 depending on the size of your class)
- Provide them with books or worksheets with the introductory activity, unit 14 from student's book S6.
- Give to them 15 minutes in order to read, analyze, interpret and discuss the activity.
- Call any two groups to present their findings (one by one). Ask other members to give their comments. You have to note down some key points and some mistakes made by students. This will help you to guide learners to find important conclusions.
- Help learners to find important conclusions.

The expected answers for activity : 14.6.2. See student's book.

Checking-up 14.6

1.

SN ₂ reactions	SN ₁ reactions
Are 2 nd order(two species involves in the rate determining step)	Are 1st order (one species involves in the rate determining step)
Attack of the nucleophile takes place from the side opposite to that of the leaving group	Attack of the nucleophile takes place from either side of the planar carbonium ion
Depends on the steric hindrance of alkyl groups (1° > 2° > 3°)	Determined by stability of carbonium ions) groups (3° > 2° > 1°)

2.

(a) The overall reaction is found by adding the elementary steps and eliminating the intermediates, adding the two elementary reactions, we get

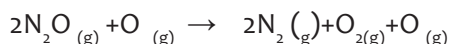

Omitting the intermediate, O(g), which occurs on both sides of the equation, gives the overall reaction:

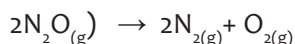

(b) The rate law for the overall reaction is just the rate law for the slow, rate determining elementary reaction, because that slow step is a unimolecular elementary reaction, the rate law is first order :

$$\text{Rate} = k[\text{N}_2\text{O}]$$

14.6. Summary of the unit

In this unit concerning rate laws and measurements, we talked about theories of reaction rates, measuring the rates of reaction, experimental determination of orders of reactions and rate law, relation between reactant concentrations and time for zero order reaction, difference between order of reaction and molecularity, and finally we talked about reaction mechanisms :

About theories of reaction rates

We saw that there exist two theories: **collision theory** and **transition state theory**:

According to collision theory a reaction occurs as a result of collision of molecules with

- a. The reactants must collide; no reaction is observed if there are no collisions between reactant compounds.
- b. The molecules must have sufficient energy (activation energy) to initiate the reaction.
- c. The molecules must have proper orientation. Unless the reactant particles possess this orientation when they collide, the collision will not be an effective one.

If the three conditions are not fulfilled, there will be ineffective collisions and therefore no reaction will occur.

About measuring the rates of reaction we saw only three methods: measuring the rates of reaction by observing change in volume, measuring the rates of reaction by observing the color change, measuring the rates of reaction by observing the mass change

About experimental determination of orders of reactions and rate laws:

We saw that the rate of reaction is determined experimentally

The order of reaction is determined using experimental data by comparing different experiments or runs:

In order to find the order of reaction with respect to one reactant we consider two runs in which the reactant we need the order of reaction has a varying concentration whereas the other has a constant concentration or the orders have known concentration (calculated before).

We saw also the relations between reactant concentration and time for a zero order, first order and third order.

We saw also how to find time for the original quantity of reactant to be halved.

Here we saw also that graphs can be used to determine the order of reaction: Those of rate against concentration and those of concentration and time.

About the difference between order of reaction and molecularity:

We saw that order of reaction differs from the molecularity as summarized in the table below:

(REAL) ORDER OF A REACTION	MOLECULARITY OF A REACTION (order due to the number of molecules)
It is the sum of the exponents (powers) of the concentrations in the rate law.	It is the number of reacting species (e.g: molecules, ions) that participate (take part) simultaneously in the formation of the transition state.
It can be fractional	It is always a whole number.
It can be zero	It cannot be zero
It can be determined experimentally	It can be calculated by simply adding the molecules of the slowest step(It is theoretical)
It can change with conditions such as pressure, temperature, or concentration	It depends to the number of molecules for a chemical equation

About reaction mechanisms we saw how to determine the order of reaction for an **elementary reaction** (reaction that occurs in one step) and for a **multistep reaction** (reaction that involves many steps):

For an elementary reaction, the rate law is determined directly from its molecularity by counting the species in the reactants.

For a multistep reaction the rate determining step is the slowest step because the slowest step limits the overall reaction rate.

14.7. Additional Information

This section provides additional content for the teacher to have a deeper understanding of the topic.

I. METHODS TO MEASURE RATES OF REACTION

Methods used to measure rates of reaction are

A. Titration:

This method is appropriate for reactions occurring in solution

Example:

- d. Consider the reaction: $\text{Br}_2(\text{aq}) + \text{HCOOH}(\text{aq}) \rightarrow 2\text{Br}^-(\text{aq}) + \text{CO}_2(\text{g}) + 2\text{H}^+(\text{aq})$
 In the reaction above $[\text{HCOOH}]$ can be determined by titration with NaOH.

- e. In the reaction

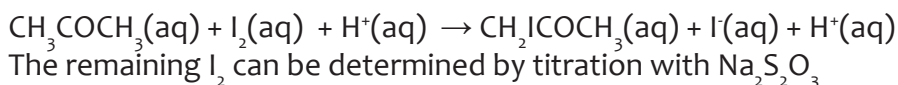

In this example, a mixture of to be titrated must be quenched (stopped) until the analysis is done. The analysis must be done by adding NaHCO_3 .

II. Optical method (Page 581 of CCS)

This method is uses Beer-Lambert law

$$A = \epsilon \times c \times l$$

Where A-absorbance

ϵ -Coefficient of molar extinction in mol/L

l-The distance between the sample in cm

c-The concentration of the solution to be analysed in mol/L
The instrument used to follow the ongoing of the reaction is spectrophotometer.

B. Conductimetric method

This measures the electrical conductivity with an appropriate instrument (conductimetric meter) to measure the conductivity for a reaction formed by mixture of ions.

Example: In the reaction

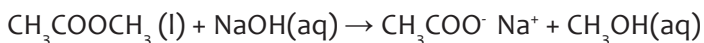

The conductivity is mainly due to sodium hydroxide (NaOH)

C. Using a polarimeter

A polarimeter is used to measure the optical rotation of optically active substances.

Examples: When sucrose is mixed with water its properties change

because it is found to be composed of glucose and fructose. The concentration of those three sugars is different.

A polarimeter can be used in factories producing cane sugar in order to measure the optical rotation of sugar produced.

Note:

Factories producing cane sugar they put alpha naphthol and concentrated sulphuric acid: The solution turns violet when there is sugar which has leaked in the pipes containing water.

D. Changing pressure:

Changing pressure of a gas can be used to monitor (follow) reactions producing gases.

E. Volumetric method (See student's book):

Measuring the rates of reaction by observing the volume changes.

F. Thermal conductivity:

For a reaction which produces gases the thermal conductivity of the gaseous mixture is measured.

II. LINK BETWEEN KINETICS OF REACTIONS AND THERMODYNAMICS

In Unit 15 of S5 (Entropy and free energy) you saw that there is condition for changes to proceed spontaneously (to happen without external help).

The condition is that the change involves a decrease in free energy, ΔG . The value of the standard free energy, ΔG° is given by Van't Hoff equation:

$$\Delta G^\circ = \Delta H^\circ - T\Delta S^\circ$$

Where, ΔG° = change in standard free energy (or Gibbs free energy)

ΔH° = change in standard enthalpy

ΔS° = change in standard entropy

If, ΔG° for a reaction is negative, we say that the reactants are thermodynamically unstable with respect to the reaction: the reaction can occur.

If, ΔG° for a reaction is positive, we say that the reactants are thermodynamically stable with respect to the reaction: the reaction cannot occur. We say the reaction is under thermodynamic control. Thermodynamic instability (ΔG° negative) is not the only condition necessary for a change to occur. That means that $\Delta G^\circ < 0$ means spontaneity of reaction but it should be noted that the reaction can be too slow in such a way that the products of reaction are not observed (the reaction may not actually occur at a measurable rate). Thermodynamics tells us only about the initial and final states of a reaction and nothing else. ΔG° may be negative but a large activation energy barrier prevents the reaction taking place at a reasonable speed. ΔG° tell us nothing about the height of the activation energy of reactants and products.

For a reaction to occur, the reactants must collide; no reaction is observed if there are no collisions between reactant compounds, the molecules must have sufficient energy (activation energy) to initiate the reaction the molecules must have proper orientation as seen before.

Example:

Methane is fuel; the oxidation of methane is thermodynamically unstable with respect to the products of oxidation :

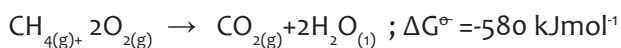

Yet oxidation does not proceed at room temperature because at room temperature very, very few molecules of methane and oxygen collide with energy equal to the activation energy. As a result, the reaction takes place so slowly as to be unobservable,

and we say the reaction is under kinetic control. For the reaction to occur the mixture has to be ignited (the lighted match plays the role of decreasing the activation energy) At higher temperatures the fraction of molecules which collide with enough energy to react increases and the reaction takes place more rapidly.

III. PREDICTING REACTION MECHANISM FROM RATE EQUATIONS

Let us consider the reaction of NO_2 and CO ,

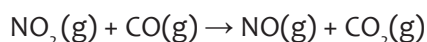

The overall balanced equation tells you that:

- 1 mole of $\text{NO}_2(\text{g})$ reacts with 1 mole of $\text{CO}(\text{g})$ to produce 1 mole $\text{NO}(\text{g})$ and 1 mole of $\text{CO}_2(\text{g})$

The overall equation does not tell you anything about reaction mechanism. For this we have to carry out some rate experiments.

The results of rate experiments carried out on this reaction show that the reaction is:

- Second order with respect to NO_2
- Zero order with respect to CO

This gives the following rate equation, $\text{Rate} = k_1 [\text{NO}]^2$

Analysis:

If a **reactant** involves in the rate equation, that reactant is involved in the rate determining step.

The order with respect to the reactant tells you how many particles of the reactant are involved in the rate determining step.

The rate equation, $\text{Rate} = k [\text{NO}_2]^2$, involves two molecules of NO_2

The two molecules of NO_2 go on the left hand side of the equation for the rate determining step.

$1 \text{NO}_2 + 1 \text{NO}_2 \rightarrow$ Two molecules of NO_2 involve in the slow, rate determining step

- The rate determining step must be followed by further fast steps.
- Together, the sum of all the steps must add up to give the overall equation.

We will propose a two -step mechanism for this reaction. We first summarize what we know so far:

1st step: $1 \text{NO}_2 + 1 \text{NO}_2 \rightarrow$ slow, rate determining step

2nd step: _____ \rightarrow _____ Fast step

Overall equation: $\text{NO}_2(\text{g}) + \text{CO}(\text{g}) \rightarrow \text{NO}(\text{g}) + \text{CO}_2(\text{g})$

Let us see what we must do:

- CO and CO₂ must be involved in the second step because they are in the overall equation
- NO₂ must be a product of the second step because one molecule of NO₂ is in the overall equation

1st step: $1 \text{ NO}_2 + 1 \text{ NO}_2 \rightarrow$ slow, rate determining step

2nd step: $\text{NO}_2 + \text{CO} \rightarrow \text{NO}_2 + \text{CO}_2$ Fast step

Overall equation: $\text{NO}_2(\text{g}) + \text{CO}(\text{g}) \rightarrow \text{NO}(\text{g}) + \text{CO}_2(\text{g})$

We are nearly there.

- The other reactant in the second step must be NO₂.
- This now gives us the product of the first step, NO and NO₃

The completed mechanism is:

1st step: $1 \text{ NO}_2 + 1 \text{ NO}_2 \rightarrow \text{NO} + \text{NO}_2$ slow, rate determining step

2nd step: $\text{NO}_2 + \text{CO} \rightarrow \text{NO}_2 + \text{CO}_2$ Fast step

Overall equation: $\text{NO}_2(\text{g}) + \text{CO}(\text{g}) \rightarrow \text{NO}(\text{g}) + \text{CO}_2(\text{g})$

14.8. Solutions of end unit assessment

Learning and assessment standards

1. Competently use Arrhenius equation to calculate the ratio of rate constant and activation energy with change in temperature, selecting the appropriate mathematical operations.
2. Correctly measure the rate of reaction and formulate simple rate equations using experimental results, independently evaluating data and evidence to reach valid conclusions.
3. Collision theory states that particles must collide with each other in correct orientation and sufficient energy to

B.React

1. According to Collision theory, particles must
B. collide with correct orientation
2. Some particles collide but bounce back afterwards it is called
B. unsuccessful collision
3. 4. The rate law for a reaction is $k[\text{A}][\text{B}]^2$
C. The reaction is second order overall.
4. A reaction was found to be zero order in A. Increasing the concentration of A by a factor of 3 will cause the reaction rate to

A. Remain constant

5. The rate law of the overall reaction is $k[A][B]^0$. Which of the following will not increase the rate of the reaction?

B. Increasing the concentration of reactant B

6. When a lit match is touched to the wick of a candle, the candle begins to burn. when the match is removed, the candle continues to burn, the match,

B. Supplies the activation energy

7. Which step of a reaction is the rate-determining step?

D. The slowest step

8. Consider the following mechanism:

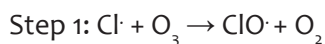

The reaction intermediate is

D. $\text{ClO} \cdot$

9. Let us consider the equation as follows

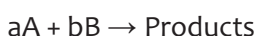

The rate law of the reaction = $k[\text{A}]^n [\text{B}]^m$

$$\text{Rate a} = k[\text{A}]_1^n [\text{B}]_1^m$$

$$\text{Rate b} = k[\text{A}]_1^n [\text{B}]_1^m$$

In order to find the order of reaction with respect to A, let us compare run 1 and run 2 where $[\text{B}]$ is constant

$$\begin{aligned} [\text{B}]_1^m &= [\text{B}]_2^m \\ \frac{\text{Rate 1}}{\text{Rate 2}} &= \frac{k[\text{A}]_1^n [\text{B}]_1^m}{k[\text{A}]_2^n [\text{B}]_2^m} \end{aligned}$$

Simplifying

$$\frac{\text{Rate 1}}{\text{Rate 2}} = \frac{[\text{A}]_1^n}{[\text{A}]_2^n}$$

$$\frac{\text{Rate 1}}{\text{Rate 2}} = \left(\frac{[\text{A}]_1}{[\text{A}]_2} \right)^n$$

$$\frac{2.0 \times 10^{-2}}{8.0 \times 10^{-2}} = 1.00 \frac{1}{4} = (0.50)^n$$

$$\log \frac{1}{4} = \log (0.50)^n$$

$$\log 0.25 = n \log 0.50$$

$$n = \frac{\log 0.25}{\log 0.50} = 2$$

The order of reaction with respect to A is 2

In order to find the order of reaction with respect to B, let us compare run 2 and run 3 where [B] is constant

$$\frac{\text{Rate 1}}{\text{Rate 2}} = \frac{k[A]_2^n [B]_2^m}{k[A]_3^n [B]_3^m}$$

$$[A]_3^n = [A]_2^n$$

The equation becomes

$$\frac{\text{Rate 2}}{\text{Rate 3}} = \frac{[B]_2^m}{[B]_3^m} = \left(\frac{[B]_2}{[B]_3}\right)^m$$

$$\frac{8.0 \times 10^{-2}}{1.6 \times 10^{-2}} = \left(\frac{0.50}{0.1}\right)^m$$

$$5 = (5)^m$$

Where $m = m = 1$

The order of reaction with respect to B is 1

(b) Rate law = $k[A]^2 [B]^1$

(c) Rate constant and its units.

i. The rate constant can be found by considering any one run (experiment), say run 1.

$$2.0 \times 10^{-2} = k (0.50)^2 (0.50)^1$$

$$2.0 \times 10^{-2} = k (0.50)^3$$

$$k = \frac{2.0 \times 10^{-2}}{(0.50)^3} = \frac{2.0 \times 10^{-2}}{0.125} = 0.16$$

ii. Units of $k = \frac{M s^{-1}}{M^3 s^{-3}} = M^{-2} s^+2$

11. Graphs shown :

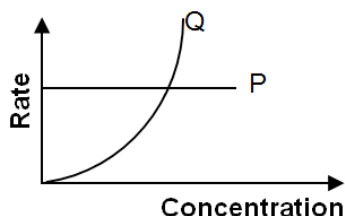

i. The order with respect to P is zero The order with respect Q is 2

ii. The rate equation for the reaction = $k[P]^0 [Q]^2$

- b) The rate equation for a reaction between R and S is $\text{Rate} = K[R]^2[S]$
 (i) The order with respect to R is 2 and the order of reaction with respect to S is 1.
 ii)

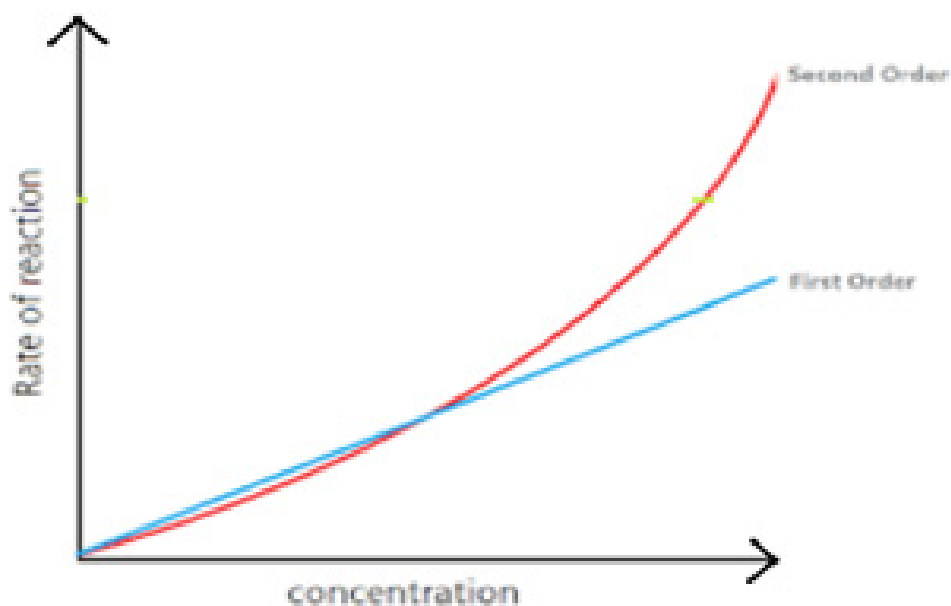

12. In order to determine the rate equation and the rate constant we have to find the order of reaction with respect to each reactant (in the exercise it is A and B)

The order of reaction with respect to B

The order of reaction with respect to B

$A + y B \rightarrow \text{Products}$

Let us consider the rate law of the reaction $= k[A]^n [B]^m$

$$\text{Rate a} = k[A]_1^n [B]_1^m$$

$$\text{Rate b} = k[A]_1^n [B]_1^m$$

In order to find the order of reaction with respect to A, let us compare experiment 2 and experiment 3 where [A] is constant

$$[A]_2^m = [A]_3^m$$

$$\frac{\text{Rate 1}}{\text{Rate 2}} = \frac{k[A]_1^n [B]_1^m}{k[A]_2^n [B]_2^m}$$

Simplifying

$$\frac{\text{Rate 1}}{\text{Rate 2}} = \frac{[B]_1^m}{[B]_2^m}$$

$$\frac{\text{Rate 2}}{\text{Rate 3}} = \left(\frac{[B]_2}{[B]_3} \right)^m$$

$$\frac{3.0 \times 10^{-3}}{1.2 \times 10^{-3}} = \left(\frac{3.0 \times 10^{-3}}{6.0 \times 10^{-3}}\right)^m$$

$$\frac{3.0 \times 10^{-3}}{1.2 \times 10^{-2}} = \left(\frac{3.0 \times 10^{-3}}{6.0 \times 10^{-3}}\right)^m$$

$$\frac{3.0 \times 10^{-1}}{1.2} = \left(\frac{1}{2}\right)^m$$

$$\log \frac{0.3}{1.2} = \log \left(\frac{1}{2}\right)^m$$

$$\frac{1}{4} = \left(\frac{1}{2}\right)^m$$

$$\left(\frac{1}{2}\right)^2 = \left(\frac{1}{2}\right)^m$$

$$m = 2$$

The **order of reaction with respect to B is 2**

In order to find the order of reaction with respect to A, let us compare run 2 and run 3 where [B] is constant: $[B]_1^m = [B]_2^m$

$$\frac{\text{Rate 1}}{\text{Rate 2}} = \frac{k[A]_2^n [B]_2^m}{k[A]_3^n [B]_3^m}$$

The equation becomes $\frac{\text{Rate 2}}{\text{Rate 3}} = \frac{[A]_2^m}{[A]_3^m} = \left(\frac{[A]_2}{[A]_3}\right)^m$

$$\frac{1.2 \times 10^{-3}}{2.4 \times 10^{-2}} = \left(\frac{2.0 \times 10^{-3}}{4.0 \times 10^{-3}}\right)^m$$

$$\frac{1}{2} = \left(\frac{1}{2}\right)^m$$

Where $m = m = 1$

The order of reaction with respect to B is 1

$$\text{Rate law} = k [A] [B]^2$$

Rate constant and its units.

The rate constant can be found by considering any one run (experiment), say run 1.

$$3.0 \times 10^{-3} = k (2.0 \times 10^{-3})^1 (3.0 \times 10^{-3})^2$$

$$3.0 \times 10^{-3} = k \times 18 \times 10^{-9}$$

$$k = \frac{3.0 \times 10^{-3}}{18 \times 10^{-9}} = \frac{1}{6} = 0.167 \times 10^6 \text{ or } k = 1.67 \times 10^5$$

$$\text{Units of } k = \frac{M s^{-1}}{M^3 s^{-3}} = M^{-2} s^{+2}$$

To find the value of Z, let us consider the experiment 4. Using the rate law, Rate = k [A] [B]².

$$Z = 1.67 \times 10^5 (5.0 \times 10^{-3})^1 (5.0 \times 10^{-3})^2$$

$$Z = 1.67 \times 5.0 \times 25 \times 10^{-9} \times 10^5$$

$$Z = 208.75 \times 10^{-4}$$

$$Z = 2.09 \times 10^{-2} \text{ M s}^{-1}$$

13. In the reaction: $P + Q + R \rightarrow \text{Product (s)}$, deduce the order of reaction with respect to P, Q and R if:

a. The rate does not change when $[R]$ is doubled. The order of reaction with respect to R Zero

b. The rate increases by 9 when $[Q]$ is tripled. The order of reaction with respect to Q is 2.

c. The rate doubles when $[P]$ is doubled. The order of reaction with respect to P is **one**

14. In the reaction: $A + B \rightarrow C$, **Rate** = $k[A][B]^2$.

a. when the concentration of A is halved. The rate of reaction is also halved

b. when the concentration of A is tripled and that of B is doubled. The order of reaction becomes 12 **times**

15. In the reaction: $2\text{NO} + \text{Br}_2 \rightarrow 2\text{NOBr}$, when the concentration of NO is reduced from $4 \times 10^{-2} \text{ M}$ to $2 \times 10^{-2} \text{ M}$ the rate falls by a factor of 4. What is the order of reaction with respect to NO? Give a reason to your answer.

Answer:

NO is of second order 2, because when the its concentration is halved its rate becomes one fourth of the first one.

Proof:

$$V_1 = k[\text{NO}]^x \quad (1)$$

$$V_2 = k[\text{NO}]^x,$$

$$\frac{V_1}{4} = k\left[\frac{\text{NO}}{2}\right]^x \quad (2)$$

Dividing equation (1) by equation (2), we have,

$$\frac{V_1}{4} = \frac{k[\text{NO}]^x}{k\left(\frac{\text{NO}}{2}\right)^x}$$

$$4 = \frac{1}{\left(\frac{1}{2}\right)^x}$$

$$2^2 = 2^x$$

$$x = 2$$

16. In the reaction: $2\text{NO}_2 \rightarrow 2\text{N}_2 + \text{O}_2$, when the concentration of NO_2 decreases from $5 \times 10^{-3} \text{ M}$ to $2 \times 10^{-3} \text{ M}$, the rate of decomposition falls by a factor of 2.5. What is the order of reaction? Give a reason to your answer.

$$V_1 = k [\text{NO}_2]^x \quad (1) \quad V_1 = k (5 \times 10^{-3})^x$$

$$V_2 = k [\text{NO}_2]^x,$$

$$\frac{V_1}{2.5} = k [\text{NO}_2]^x \quad (2) \quad \frac{V_1}{2.5} = k (2 \times 10^{-3})^x$$

Dividing equation (1) by equation (2), we have,

$$\frac{V_1}{\frac{V_1}{2.5}} = \frac{k(5 \times 10^{-3})^x}{k(2 \times 10^{-3})^x}$$

$$2.5^1 = 2.5^x$$

$$x = 1$$

The order of reaction is 1

17. The order of reaction with respect to $(\text{CH}_3)_3\text{C-Br}$ is 1

The total order of reaction 1

Write the rate equation for this reaction, Rate = $k [(\text{CH}_3)_3\text{C-Br}]$

Rate-concentration graph for the hydrolysis of $(\text{CH}_3)_3\text{C-Br}$.

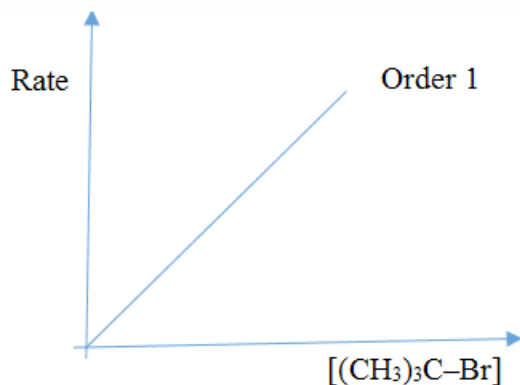

18. a) Paracetamol has a biological half-life of 380 seconds. How long will it take for the level of paracetamol in the body to fall to one-sixteenth of its original value?

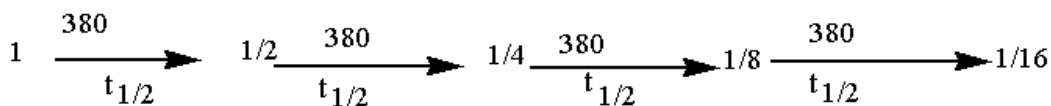

$$t = 380 \times 4 = 1520 \text{ s}$$

b) 50% of a first order reaction is complete in 23 minutes. Calculate the time required to complete 90% of the reaction.

$$\ln \frac{[A]_t}{[A]_0} = -kt$$

$$k = \frac{0.693}{23} = 0.03013 / \text{min}$$

$$\ln \frac{10\%}{100\%} = -0.03013 / \text{min } t$$

$$-2.303258 = -0.03013 t$$

$$t = \frac{2.30258501}{0.03013}$$

$$t = 74.421675 = 74.4 \text{ min} = 74.4 \times 60 = 4585.30 \text{ s}$$

14.9. Additional activities

Remedial Activities: Suggestion of Questions and Answers for remedial activities for slow learners.

1. A solution of Q, of concentration 0.20 mol dm^{-3} undergoes a first –order reaction at an initial rate of $3.0 \times 10^{-4} \text{ mol}^{-3} \text{ s}^{-1}$.

Calculate rate constant.

Solution

For a first –order reaction

$$\text{Initial rate} = k[\text{Q}]_0$$

$$3.0 \times 10^{-4} \text{ mol dm}^{-3} \text{ s}^{-1}$$

$$= k \times 0.20 \text{ mol dm}^{-3}$$

$$\text{The rate constant } k = 1.5 \times 10^{-3} \text{ s}^{-1}$$

The unit of a first –order rate constant is time^{-1} .

2. A second –order reaction takes place between the reactants P and Q, which are both initially present at concentration 0.20 mol dm^{-3} . If the initial rate of reaction is $1.6 \times 10^{-4} \text{ mol dm}^{-3} \text{ s}^{-1}$

What is the rate constant ?

$$\text{Initial rate} = k [\text{P}]_0 [\text{Q}]_0 = 1.6 \times 10^{-4} \text{ mol dm}^{-3} \text{ s}^{-1}$$

$$1.6 \times 10^{-4} \text{ mol dm}^{-3} \text{ s}^{-1} = k \times (0.20 \text{ mol dm}^{-3})^2$$

$$\text{The rate constant, } k = 4.0 \times 10^{-3} \text{ dm}^3 \text{ mol}^{-1} \text{ time}^{-1}$$

3. The rate constant for the reaction

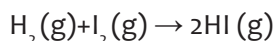

is 2.7×10^{-4} at 600 K and 3.5×10^{-3} at 650 K. Calculate the activation energy of reaction

Solution

$$k_1 = 2.7 \times 10^{-4}$$

$$k_2 = 3.5 \times 10^{-3}$$

$$T_1 = 600 \text{ K}$$

$$T_2 = 650 \text{ K}$$

$$R = 8.31 \text{ J/K.mol}$$

$$\text{Equation: } \ln \frac{k_1}{k_2} = -\frac{E_a}{R} \left(\frac{1}{T_2} - \frac{1}{T_1} \right)$$

$$\ln \frac{2.7 \times 10^{-4}}{3.5 \times 10^{-3}} = -\frac{E_a}{8.31} \left(\frac{1}{650} - \frac{1}{600} \right)$$

$$-2.5620 = -\frac{E_a}{831} \left(\frac{600 - 650}{390000} \right)$$

$$2.5620 = \frac{50E_a}{3240.9000}$$

$$E_a = \frac{3240900 \times 2.5620}{50}$$

$$E_a = 1.66 \times 10^5 \text{ J}$$

10. A radioactive sample of caesium -136 decays from 480 cpm to 60 cpm in 42 days. what is its half-life?

Solution:

$$\text{Decrease in amount of caesium -136} = \frac{60 \text{ cpm}}{480 \text{ cpm}} \times 100\% = 12.5\%$$

The isotope has decayed from 100% → 50% → 25% → 12.5%

Half-life = 14 days

Therefore the time for three half-lives = 14 days × 3 = 42 days

11. The half-life of radium is 1590 years. How long will it take for a sample of radium to decay to 25% of its original radioactivity?

Solution:

To decay to 50% of its original activity takes one half-life = 1590 years. To decay from 50% to 25% of its original activity takes another half-life of 1590 years.

Total time = 1590 years × 2 = 3180 years

Consolidation activities:

1. Consider the following reaction: $2\text{NO}(\text{g}) + \text{Br}_2(\text{g}) \rightarrow 2\text{NOBr}(\text{g})$

(a) Write the rate law for the reaction, assuming it involves a single elementary reaction.

(b) Is a single step mechanism likely for this reaction?

Solution

(a) Rate = $k[\text{NO}]^2[\text{Br}_2]$

(c) No, because termolecular reactions are less probable

2. The possible mechanism for the reaction

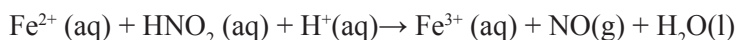

is in three steps as shown below

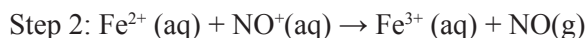
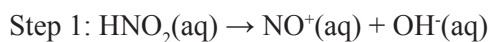

i. Identify the intermediate species if any and

ii. Write the rate laws for each elementary process.

Solution

i. Intermediate species are $\text{NO}^+(\text{aq})$ and $\text{OH}^-(\text{aq})$

ii. The rate laws are respectively $k_1 [\text{HNO}_2]$, $k_2 [\text{Fe}^{2+}][\text{NO}^+]$ and $k_3 [\text{H}^+][\text{OH}^-]$

The possible mechanism for the reaction

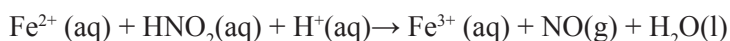

is in three steps as shown below

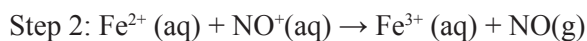
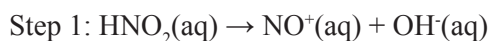

i. Identify the intermediate species if any and

ii. Write the rate laws for each elementary process.

Solution

i. Intermediate species are $\text{NO}^+(\text{aq})$ and $\text{OH}^-(\text{aq})$

ii. The rate laws are respectively $k_1 [\text{HNO}_2]$, $k_2 [\text{Fe}^{2+}][\text{NO}^+]$ and $k_3 [\text{H}^+][\text{OH}^-]$

3. The following table shows the rate constants for the rearrangement of methylisonitrile at various temperatures (these are data in figure)

Temperature ($^{\circ}\text{C}$)	$k(\text{s}^{-1})$
189.7	2.52×10^{-5}
198.9	5.25×10^{-5}
230.3	6.30×10^{-4}
251.2	3.16×10^{-3}

a. From these data, calculate the activation energy for the reaction.

b. What is the value of the rate constant at 430.0 K?

Solution:

a. We must first convert the temperatures from the degrees Celsius to Kelvins and then we then take the inverse of each temperature, $1/T$, and the nature log of constant, $\ln k$, this gives us the table shown below

T(K)	$1/T(K^{-1})$	$\ln k$
462.9	2.160×10^{-3}	-10.589
472.1	2.118×10^{-3}	-9.855
503.5	1.986×10^{-3}	-7.370
524.4	1.907×10^{-3}	-5.757

Graph of $\ln k$ against $1/T$

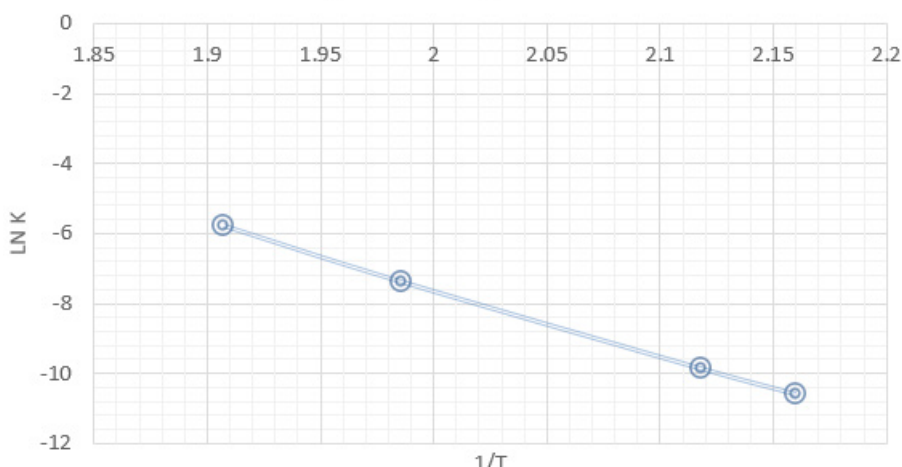

$$\text{Slope} = \frac{\Delta y}{\Delta x} = \frac{-6.6 - (-10.4)}{0.00195 - 0.00215} = -1.9 \times 10^4$$

$$\text{Slope} = -\frac{E_a}{R}$$

$$E_a = -(\text{slope})(R) = -(-1.9 \times 10^4 \text{ k})(8.314 \frac{\text{J}}{\text{mol-K}}) (\frac{1 \text{ kJ}}{1000 \text{ J}})$$

$$= 1.6 \times 10^2 \text{ kJ/mol}$$

$$= 160 \text{ kJ/mol}$$

The slope of the line is obtained by choosing two well – separated points, as shown, and using the coordinates of each

Because logarithms have no units, the numerator in this equation is dimensionless. The units of $1/T$, namely, K^{-1} and therefore the overall units for the slope are K .

The slope equals $-E_a/R$. We use the value for the molar gas constant R in units of $J/\text{mol-K}$

4. (a) in the presence of an acid, sucrose is converted into a mixture of glucose and Fructose according to the equation.

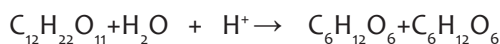

The following data was obtained by a student at 25°C for reaction above .

Sucrose conc./mol dm ⁻³	0.08	0.06	0.04	0.020
Rate/mol dm ⁻³ s ⁻¹	0.004	0.003	0.002	0.001

Draw a suitable graph and use it to determine

- (i) The order of reaction
 - (ii) The rate constant
 - (iii) The rate reaction when the concentration of sucrose is 0.12mol dm³
- (b) A certain element B reacts with water (in a single step)according to the equation :

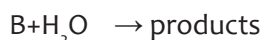

- (i) What is the molecularity of this reaction ?
- (ii) What is the order of reaction in a very dilute solution?

Solution ::

(i)

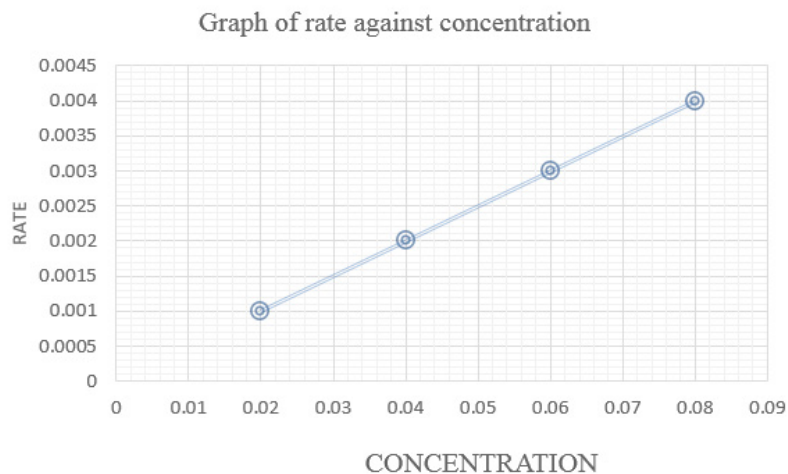

Order of reaction: For a first order reaction the plot of rate of reaction against concentration gives a straight- line graph through the origin.

(ii) The rate of constant is equal to the gradient(slope)

$$\frac{0.004}{0.08} - \frac{0.002}{0.04} = \frac{0.002}{0.04}$$

$$= 5.0 \times 10^{-2}\text{S}^{-1}$$

(iii) Rate equation is

$$\text{Rate} = k [\text{C}_{12}\text{H}_{22}\text{O}_{11}]$$

$$= 5.0 \times 10^{-3} \times 0.12$$

$$= 6.0 \times 10^{-3} \text{ mol dm}^{-3} \text{ s}^{-1}$$

(b) (i) molecularity = 2

(ii) Since the reaction occurs in a single step and since water is present in excess, the reaction is one.

Extended activities:

1. The following kinetic data were obtained by a student for a certain reaction in which W is converted to Y at 25°C .

Time /min	0	9	18	27	40	54	72	105	118
Conc. of W /mol dm ³	0.106	0.096	0.077	0.065	0.043	0.054	0.043	0.030	0.025

- Plot a graph of concentration against time.
- From the graph deduce the time taken for the concentration of W.
 - To be reduced to half the original value
 - To be reduced to quarter the original value.
- What is the order of reaction with respect to W?
- Write the rate equation for the reaction in which W is changed to Y
- Hence determine the rate constant and state its units.

Solution

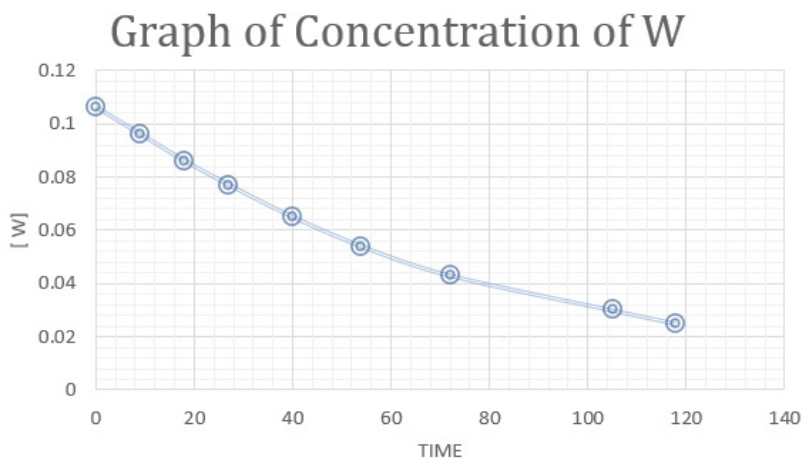

b. (i) Time taken for the concentration to decrease from $0.106 \text{ mol dm}^{-3}$ (original) to half ($0.053 \text{ mol dm}^{-3}$) = 55.8 mins

(ii) Since the two half-life times are the same, the order of reactions is one

Original concentration	Half concentration	Time taken
$0.1016 \text{ mol dm}^{-3}$	0.53	55.8 min
0.53 mol dm^{-3}	0.265	56 min

a. Rate = $k [W]$

b. Half-life = $\frac{55.8+56}{2} = 55.9 \text{ min}$

From the equation $t_{1/2} = \frac{0.693}{K}$

$$k = \frac{0.693}{t^{1/2}} = \frac{0.693}{55.9} = 1.24 \times 10^{-2} \text{ min}^{-1}$$

1. The data below refers to the decomposition of substance X

Time(s)	0	100	200	300	400	600
$[x] \text{ mol dm}^{-3}$	0.1	0.075	0.0558	0.0445	0.0378	0.0297

Plot a graph of $\frac{1}{[X]}$ against time and use it to determine the rate constant for the reaction.

Answer

Time	0	100	200	300	400	600
$[x] \text{ mol dm}^{-3}$	0.1	0.075	0.0558	0.0445	0.0378	0.0297
$\frac{1}{[X]}$	10	13.33	17.92	22.47	26.45	33.67

1/[X] against time

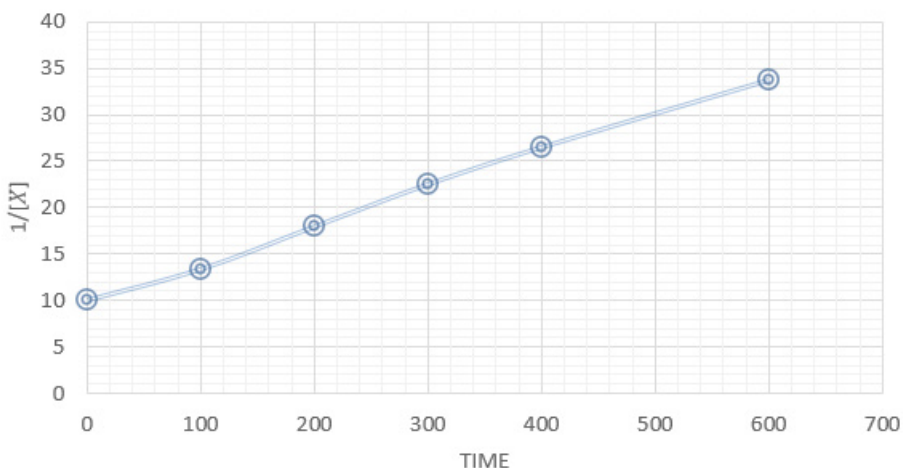

$$k = \frac{\Delta y}{\Delta x} = \frac{(33.67 - 13.33)}{(600 - 100) \text{ sec}} \text{ mol dm}^3$$

$$k = 0.04068 \text{ mol dm}^{-3} \text{ s}^{-1}$$

3. (a) Explain what is meant by the terms :

- (i) order of reaction
- (ii) molecularity of a reaction

(b) the data below were obtained from the following homogeneous reaction

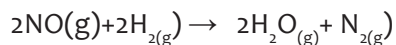

Experiment number	Concentration NO in mol ⁻¹	Concentration of H ₂ in mol ⁻¹	Rate of formation of N ₂ in mol ⁻¹ s ⁻¹
1	5.00 × 10 ⁻⁵	1.00 × 10 ⁻⁴	4.5 × 10 ⁻⁴
2	5.00 × 10 ⁻⁴	2.00 × 10 ⁻⁴	9.0 × 10 ⁻⁴
3	1.00 × 10 ⁻⁴	500 × 10 ⁻⁴	9.0 × 10 ⁻⁴
4	200 × 10 ⁻⁴	5.00 × 10 ⁻⁴	3.6 × 10 ⁻⁴

If the rate equation for the reaction is given by

$$\frac{d[\text{N}_2]}{dt} = k [\text{NO}]^x [\text{N}_2]^y$$

- (i) Deduce the values of x and y
- (ii) Calculate the effect on the rate of reaction if [no] is halved and that of h₂ kept constant
- (iii) State the effects on the reaction rate by doubling [NO] and increasing [H₂] three times

a. consider the reaction

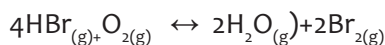

A student wrote the rate for this reaction with respect oxygen as

$$\frac{d[\text{O}_2]}{dt} = -k [\text{HBr}]^4 [\text{O}_2]$$

In practice it is found that the rate law for this reaction

$$\frac{d[\text{O}_2]}{dt} = -k_1 [\text{HBr}] [\text{O}_2]$$

Explain what it is wrong with the rate law given by the student?

(i) The rate law for this reaction with respect to HBr is given by:

$$\frac{d[\text{HBr}]}{dt} = -k_2 [\text{HBr}] [\text{O}_2]$$

Derive from the equation the relationship between k_1 and k_2

Solution

(a)(i) Order of reaction is the sum of the powers to which the concentration terms of the reactants are raised to in a given rate equation.

(Or The power to which the concentration term of a single reactant is raised in a given rate equation)

Consider the reaction



If the rate equation is given by:

$$\text{Rate} = k [\text{A}] [\text{B}]^2$$

Then order of reaction with respect to reactant A is one while the order with respect to reactant B is 2. This gives an overall order of reaction as $1+2=3$. Order experimentally determined

(ii) Molecularity of a reaction is number of ions or molecules participating in reaction.

Example: In the reaction

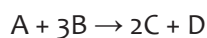

$$1+3 = 4$$

(b) in the rate equation

$$\frac{d[\text{N}_2]}{dt} = k [\text{NO}]^x [\text{H}_2]^y$$

x and y are the orders of reactions with respect to reactants NO and H_2 respectively.

To determine the order of reaction with respect to NO, x , we consider those experiments in which the concentrations of H_2 do not change i.e. experiment (3) and (4).

From experiment 3 to 4 the concentration of NO doubles while the rate increases by $\frac{3.6 \times 10^{-4}}{9.0 \times 10^{-5}} = 4 \text{ times}$

Therefore, since doubling [NO] increases the rate $4(2^2)$ times,

Therefore, the order of reaction with respect to NO = 2

Therefore $x=2$

To determine the order of reaction with respect to H_2 , y , we also consider those experiments in which now the concentration of H_2 changes but those of NO remain constant i.e., experiments (1) and (2)

In moving from experiment 1 to 2 the concentration of H_2 changes by a factor of

$$\frac{2.00 \times 10^{-4}}{1.00 \times 10^{-4}} = 2$$

The rate changes by a factor of $\frac{9.0 \times 10^{-4}}{4.5 \times 10^{-4}} = 2$

Therefore by doubling the $[H_2]$, the rate also doubles.

The order with respect to H_2 is hence 1

Therefore $y=1$

(ii) The rate equation is therefore now $\frac{d[N_2]}{dt} = k [NO]^2 [H_2]$

you now choose any experiment to determine k .

Let us consider experiment (2)

$$\text{Therefore } k = \frac{9.0 \times 10^{-4}}{(5.00 \times 10^{-4})^2 (2.00 \times 10^{-4})} \quad \text{units} = \frac{\text{mol l}^{-1} \text{s}^{-1}}{(\text{Mol l}^{-1})^3}$$

$$= \frac{\text{s}^{-1}}{\text{mol}^2 \text{l}^{-2}}$$

$$= \frac{9 \times 10^{-4}}{5.0 \times 10^{-11}}$$

$$= 1.8 \times 10^7 \text{ mol l}^2 \text{ s}^{-1}$$

(iii) By halving [NO] and $[H_2]$ kept constant the rate changes by $(1/2)^2 = 1/4$

The rate changes by $1/4$ times.

(iv) By doubling [NO] the rate changes by 2^2 times = 4 times

By increasing the $[H_2]$ 3 times, the rate also increases 3 times

Therefore overall change in rate : $4 \times 3 = 12$ times

(c)(i) the student determined the rate equation from stoichiometric equation in which 4 and 1 are the stoichiometric amounts of HBr and O_2 respectively as in equation .

$$\frac{d[O_2]}{dt} = \frac{d[HBr]}{dt}$$

$$\text{i.e. } -k_1 [HBr][O_2] = -k_2 [HBr][O_2]$$

Therefore $k_1 = k_2$

4. The table below shows some data for the reaction:



Experiment	[A]/ (mol dm ⁻³)	[B]/ (mol dm ⁻³)	Rate (mol dm ⁻³ S ⁻¹)
1	1.00×10^{-2}	2.80×10^{-3}	2.10
2	5.00×10^{-3}	2.80×10^{-3}	1.10
3	1.00×10^{-2}	5.60×10^{-3}	4.30

(i) Determine the order of reaction with respect to A and B.

(ii) Write the rate equation for the reaction

(iii) Calculate the rate constant for the reaction and give its units.

(iv) Calculate the rate of reaction when the concentrations of A and B are 8.50×10^{-3} and $3.83 \times 10^{-3} \text{ mol dm}^{-3}$ respectively.

(c) State what happens to the order of reaction in (b) if B was in a large excess. Explain your solution.

(d) Draw a fully labeled diagram for the reaction

Solution

a. Order of reaction is the sum of powers to which the concentrations of reactants are raised in the experimental rate equation.

Molecularity of a reaction is the sum of the number of species required to form an activated complex or total number of species involved in the slowest step (or rate determining step).

b. (i) order with respect to A : in experiments 1 and 2, When the concentration of A doubles, while keeping that of B constant, rate doubles, which shows that order with respect to A = 1

Order with respect to B : in experiments 1 and 3, when the concentration of B is doubled while keeping that of A constant, rate doubles, which shows that order with respect to B = 1.

(ii) Rate = $k[A][B]$

(iii) $k = \frac{[\text{Rate}]}{[A][B]}$, and using results of experiment 1 (or any other experiment 1)

$$k = \frac{2.1 \text{ mol dm}^{-3} \text{ s}^{-1}}{1.00 \times 10^{-2} \text{ mol dm}^{-3} \times 2.80 \times 10^{-3} \text{ mol dm}^{-3}} \\ = 7.50 \times 10^4 \text{ mol}^{-1} \text{ dm}^3 \text{ s}^{-1}$$

(iv) Rate = $7.50 \times 10^4 \times 8.50 \times 10^{-3} \times 3.83 \times 10^{-3} = 2.44 \text{ mol dm}^{-3} \text{ s}^{-1}$

- c. The order will change from 2 to 1. Since B was in large excess, its concentration would be taken to be constant during the reaction and the rate would depend on concentration of A only.

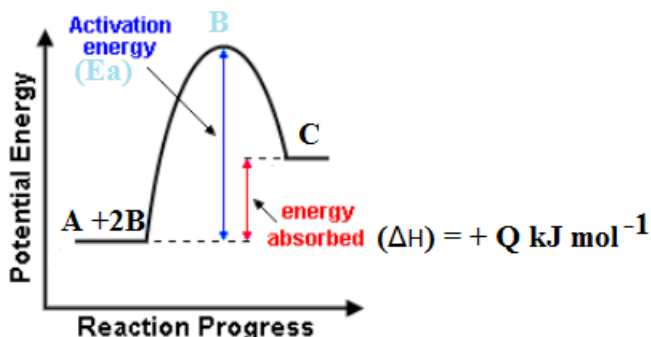

5.(a) Explain what is meant by the following terms :

(i) Transition state

(ii) Activation energy

(b) The reaction $2A_{(g)} + B_{(g)} \rightarrow C_{(g)}$ was studied at a number of temperatures and the following data obtained.

Temperature	12	60	112	203
$k/ \text{dm}^6 \text{mol}^{-2}\text{S}^{-1}$	2.34	13.2	52.5	316

Calculate the activation energy for the reaction

Solution ,

(a) (i) Transition state is a state of maximum potential energy during a chemical reaction in which the substance present at that state can now form the products of the reaction or can give back the reactants.

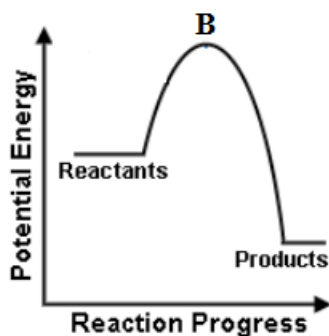

B is the transition state

(ii) Activation energy barrier that must first be overcome for any chemical reaction to occur.

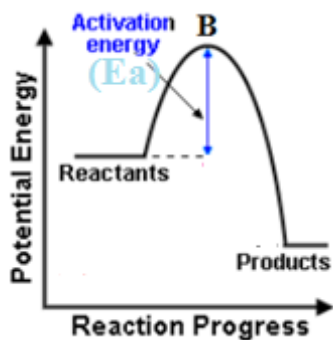

(b) The relationship between rate constants at two different temperatures and activation energy is :

$$\log\left[\frac{k_2}{k_1}\right] = \left[\frac{Ea}{2.303R}\right] \left[\frac{T_2 - T_1}{T_1 T_2}\right]$$

Where k_1 and k_2 are constants at temperatures T_1 and T_2 respectively .

$$T_1 = 12 + 273 = 285 \text{ K}, T_2 = 60 + 273 = 333 \text{ K}$$

Ea = activation energy

$$\text{Therefore } \log\left[\frac{13.2}{2.34}\right] = \frac{Ea}{2.303 \times 8.314} \left[\frac{333 - 285}{285 \times 333}\right]$$

$$0.75 = \frac{Ea}{19.147} \left[\frac{48}{94905}\right]$$

$$0.75 = \frac{48 Ea}{1817146}$$

$$Ea = \frac{0.75 \times 1817146}{48}$$

$$Ea = 2.84 \times 10^4 \text{ joules} = 284 \text{ kJ}$$

6.(a) Propanone and iodine in presence of an acid catalyst react according to the equation

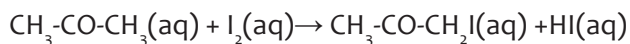

The reaction is first order with respect to propanone and independent of the concentration of iodine

(i) Write an expression for the rate law

(ii) Describe briefly how the order with respect to iodine can be determined

(c) The following data were obtained for the reaction

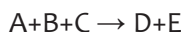

Experiment number	Initial concentration of A in mol L ⁻¹	Initial concentration of B in mol ⁻¹ L ⁻¹	Initial concentration of C in mol ⁻¹ L ⁻¹	Rate of mol ⁻¹ min ⁻¹
1	0.1	0.1	0.1	1.0 x 10 ⁻⁴
2	0.1	0.3	0.1	9.0 x 10 ⁻⁴
3	0.3	0.3	0.1	9.0 x 10 ⁻⁴
4	0.1	0.1	0.3	1.0 x 10 ⁻⁴

(i) Determine the order of reaction with respect to A, B and C. Explain how you arrive at the

(ii) Write the rate equation for the reaction

(iii) If the initial concentration A, B and C were each 0.4 moles, calculate the initial rate of reaction

Solution

(a) (i) Rate = $k [\text{CH}_3\text{C}-\text{CH}_3]$ k = rate constant

(ii) A fixed volume of standard iodine solution is added to an excess of propanone solution in a flask. To this mixture is now added a fixed volume of dilute sulphuric acid and the time at which the acid is added recorded. At exactly 5 minutes from the adding of the acid, the mixture is pipette and then quickly run to a flask containing some sodium hydrogen carbonate solution which stops the reaction. The resultant mixture is then titrated with standard solution of sodium thiosulphate used is recorded. The procedure above is repeated but the amount of iodine, V_t , left is determined after longer times e.g, 10, 15, 20, 25, 30 min etc before adding the NaHCO_3 .

The initial amount of iodine (V_0) is obtained by titrating the original iodine solution directly with the sodium thiosulphate solution.

A graph of V_t against time is then plotted and is a straight –line graph.

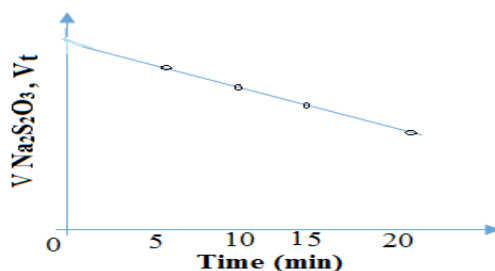

Note :-volume of thiosulphate, V_t , at various times is proportional to the concentration of iodine left at those times.

-Gradient gives the rate constant whose unit is $\text{mol cm}^{-3} \text{s}^{-1}$

-The NaHCO_3 stops the reaction because it reacts with the catalyst H_2SO_4

(b) In experiment 1 and 2 the order of reaction with respect to reactant B can be determined since the concentration of reactants A and remain constant .

In experiment 1 and 2 as the concentrations of B increases three times $\frac{0.30.3}{0.10.1}$, the rate increases nine times $\frac{9.0 \times 10^{-4}}{1.0 \times 10^{-4}}$

Therefore the order with respect to B is 2.

In experiments (1) and (4) the concentrations of the reactants A and B remain constant as that of C increases three times. The effect on the rate is that the rate remains constant,

Therefore the order of reaction with respect to reactant C is Zero .In experiments (2) and (3) as the concentration of B and C remain constant that of A increases three times .The rate increases three times also . Therefore the order with respect to reactant A is 1.

$$\text{(ii) Rate} = k[\text{A}]^1[\text{B}]^2[\text{C}]^0$$

$$\text{Rate} = K[\text{A}][\text{B}]^2$$

(iii) Here the rate constant should first be calculated from the equation

$$\text{Rate} = k[\text{A}][\text{B}]^2$$

$$K = \frac{\text{Rate}}{[\text{A}][\text{B}]^2}$$

Consider experiment (3)

$$\text{Therefore } K = \frac{2.7 \times 10^{-3}}{0.3 \times 0.3^2} = 1 \times 10^{-1} \text{ min}^{-1}$$

$$K = 1 \times 10^{-1} \text{ mol}^{-2} \text{ l}^2 \text{ min}^{-1}$$

Therefore Rate = $k[\text{A}][\text{B}]^2$

$$= 1 \times 10^{-1} \times 0.4 \times (0.4)^2$$

$$= 6.4 \times 10^{-3} \text{ mol l}^{-1} \text{ min}^{-1}$$

7. For a reversible reaction indicated below, the activation energy, E_a and ΔH for the forward reaction are +180 kJ and + 40Kj respectively.

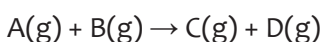

The following data were obtained experimentally on the rates of reaction under different conditions at 298 K.

Experiment	[A] (mol dm ³)	[A] (mol dm ³)	Rate (mol dm ³ s ⁻¹)
1	2.0×10^{-2}	1.0×10^{-2}	1.0×10^{-2}
2	2.0×10^{-2}	2.0×10^{-2}	2.0×10^{-2}
3	4.0×10^{-2}	2.0×10^{-2}	4.0×10^{-2}

(i) Write an expression for the experimental rate equation using the data in the table, and show your reasoning.

(ii) Calculate the rate constant at 298 K and give its units.

(a)(i) Sketch a diagram showing the energy versus reaction coordinate for this reaction. Label the diagram fully and indicate E_a and ΔH on the diagram.

(iii) What is the activation energy for the backward reaction?

(b) i. How does increase in temperature affect the equilibrium constant?

ii. How would you expect the rate of the reaction to change if the temperature was raised? Explain your answer.

(d) Sketch on a diagram, the variation of concentration of D with time during the reaction after A and B are mixed for two temperatures T_1 and T_2 , where T_1 is less than T_2 .

Solution

$$\frac{2.0 \times 10^2}{1.0 \times 10^2} = \left(\frac{2.0 \times 10^{-2}}{1.0 \times 10^{-2}} \right)^n \quad (1) \text{ and } (2) \text{ above where } [A] \text{ is constant.}$$

$$2 = 2^n; n = 1$$

Therefore the order of reaction with respect to [B] is 1.

Because where [B] is doubled and [A] kept constant, the rate of reaction doubles, which means the order of reaction with respect to [B] is 1.

$$\frac{4.0 \times 10^2}{2.0 \times 10^2} = \left(\frac{4.0 \times 10^{-2}}{2.0 \times 10^{-2}} \right)^m \quad (3) \text{ where } [B] \text{ is constant}$$

$$2 = 2^m; m = 1$$

Therefore the order of reaction with respect to [A] is 1.

Because where [A] is doubled and [B] is kept constant, the rate of reaction doubles, which means that the order of reaction with respect to [A] is 1.

Rate = $k[A][B]$; where k is rate constant.

(ii) Using results of experiment 1, (or any other set of results)

$$k = \frac{1.0 \times 10^2}{(2.0 \times 10^{-2})(1.0 \times 10^{-2})} = 5 \times 10^5 \text{ mol}^{-1} \text{ dm}^3 \text{ s}^{-1}$$

a. Graph

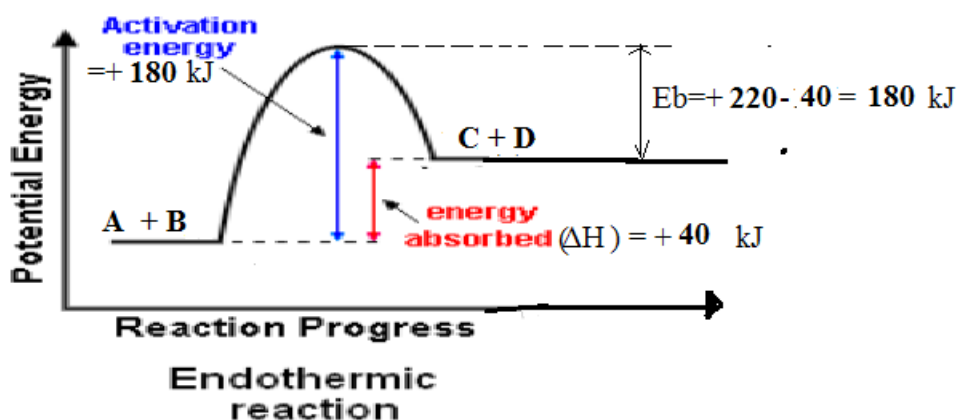

(ii) Activation energy for backward reaction, E_b (refer to graph): $180 - 40 = 140$ kJ

c) (i) If the temperature is raised, it favours the forward reaction, which is endothermic.

(ii) The rate of reaction increases with increases with increase in temperature because the number of molecules with activation energy increases.

b. Graph

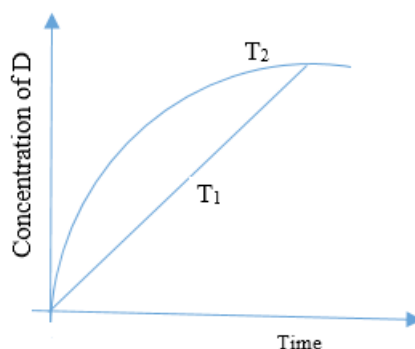

8. The kinetics data for the hydrolysis of an alkyl halide is shown in the table below

Time(s)	0	100	150	300	400	600	800
Concentration of reactant (mol dm ⁻³)	1.00	0.80	0.70	0.50	0.40	0.25	0.15

Plot a graph of concentration against time.

Graph of conc.of RX against time

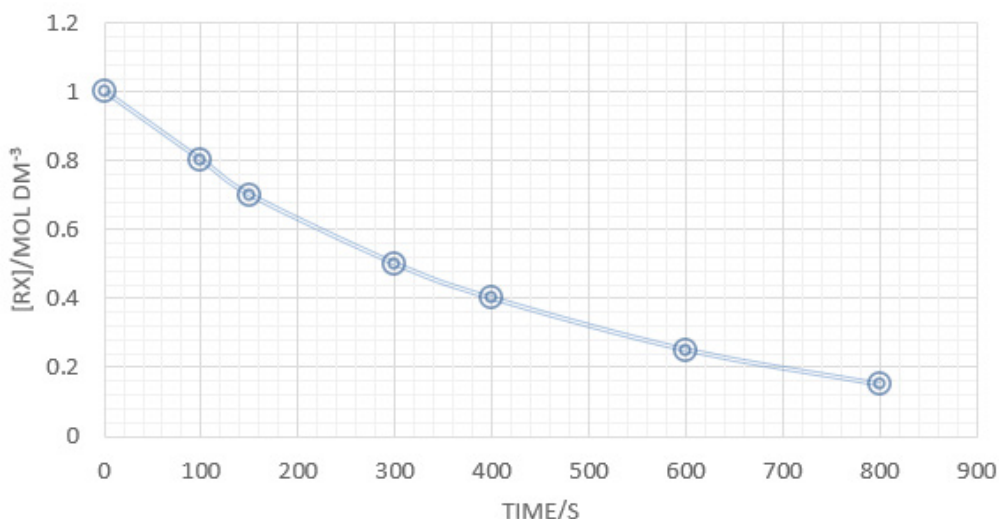

Fig.: Graph of concentration of the alkyl halide (RX) against time

(i) Use the graph to determine the half-life and order of the reaction.

The half-life is 300 s, and the reaction is first order from the shape of the graph

(ii) Calculate the rate constant, k , for the reaction

$$k = \frac{0.693}{t} \text{ for a first order reaction} \quad k = \frac{0.693}{t} \text{ for a first order reaction.}$$

$$k = \frac{0.693}{t} = \frac{0.693}{300} = 2.31 \times 10^{-3} \text{ mol dm}^{-3} \text{ s}^{-1}$$

(iii) Determine the rate of reaction at 100 seconds.

The rate of reaction at any given time (instantaneous rate) is equal to the gradient of a straight line tangent to the curve at that time.

$$\text{Rate} = \frac{0.64 - 0.36}{400 - 180} = \frac{0.28}{220} = 0.0012727 = 1.27 \times 10^{-3} \text{ M s}^{-1}$$

(iv) Compare the rate at 100 seconds to that at 600 seconds. Give a reason.

Rate at 600 s

$$\text{Rate} = \frac{0.32 - 0.16}{700 - 500} = \frac{0.16}{200} = 0.0008 = 0.8 \times 10^{-3} \text{ M s}^{-1}$$

Therefore the rate at 100 s is greater than the rate at 600 s because at 100 s the concentration of the reactants, hence the frequency of collision of reactants, is greater than that at 600 s.

UNIT 15: RADIOACTIVITY

15

15.1. Key unit competence

To be able to explain the importance and dangers of radioisotopes in everyday life.

15.2. Prerequisite knowledge and skills

Students will learn Radioactivity well if they have understanding on: atomic structure (unit 1 in senior four), periodic table of elements (unit 5 in senior four), chemical bonding (unit 3&4 of senior four), chemical equations (unit 10 in senior one), chemical energetics (unit 18 in senior four); factors that affect the rate of reaction and rate laws and measurements both constituting an interesting branch of chemistry known as “chemical kinetics” (in senior six unit 13&14).

15.3. Cross-cutting issues to be addressed

Environment and sustainability

This unit is about nuclear radioactivity which is directly linked to the environment as many radiations are natural and we are continuously exposed to them. As provided in the student’s book, not all radiations are harmful but some of them are harmful.

Everything around us is radioactive. Plants can become radioactive when radioactive material enters the soil and is taken up by root systems or when radioactive particles in the air settle on edible portions of the plant. Milk and meat can become contaminated when animals eat grass and other plants that are radioactive. When humans eat radioactive plants or animals, the radioactive substances, such as iodine-131, can settle in particular organs like the thyroid gland. This can increase the risk of thyroid cancer. Children are more vulnerable than adults to exposure to radiation because they are still growing and can absorb more contamination.

Radioactive materials that decay spontaneously produce ionizing radiation, which has sufficient energy to strip away electrons from atoms (creating two charged ions) or to break some chemical bonds. Any living tissue in the human body can be damaged by ionizing radiation. The body attempts to repair the cellular damage, but sometimes the damage is of a nature that cannot be repaired or it is too severe or widespread to be repaired. Also mistakes made in the natural repair process at the cellular level can lead to cancerous cells.

Personal exposure to radiation can be reduced in either of these ways:

- Reduce the time spent near the source of radiation
- Increase the distance from the source of radiation
- Place shielding material between you and the source of radiation
- Avoid eating radiation-contaminated foods once known. Sometimes the government instructs the population from not eating some kinds of food or meat of some animals due to some diseases they can cause. Some of these diseases are related to radiation issues.

This cross-cutting issue can be addressed to students in the introduction of unit 15 and/or while teaching the uses of radioisotopes as well as their health hazards (**student's book, unit 15 section 15.6 and 15.8 respectively**).

Financial education

As seen in student's book, one of the main applications of radioactivity, especially in nuclear fission and nuclear fusion, is the production of energy.

Nuclear power does not produce polluting combustion gases. So, like renewable energy sources, it could play a key role in helping to reduce global greenhouse gas emissions and in tackling global warming, especially as electricity demand rises in the years ahead. Currently, the perceived problem with nuclear energy from an environmental point of view is how to manage its radioactive waste. Solutions do exist, in particular the technique of burying the waste deep below the ground in engineered facilities, known as geological disposal. The challenge is to convince the public of its safety and reliability.

Radioactive waste is an inevitable by-product of the application of ionizing radiation, whether it be in nuclear medicine (for diagnosis and treatment), industrial applications (for example, for finding new sources of petroleum or producing plastics), agricultural applications (notably for the conservation of foodstuffs), or of course the production of electricity. The radioactive waste produced by the latter represents less than 1% of the total toxic wastes generated in those countries that use nuclear energy to generate electricity, but at the same time this waste has the highest levels of radioactivity.

The long-term solution currently preferred by specialists consists of placing the waste in a deep (500 metres below the surface) and stable geological setting, such as granite, clay, tuff and salt formations that have remained unchanged for millions of years. The aim is to ensure that such wastes will remain undisturbed for the few thousand years needed for their levels of radioactivity to decline to the point where they no longer represent a danger to present or future generations.

As a general rule, the natural security afforded by the chosen geological formation is enhanced by additional precautionary measures. The wastes are immobilized in an insoluble form, in blocks of glass for example, and then placed inside corrosion-resistant containers; spaces between waste packages are filled with highly pure, impermeable clay; and the repository may be strengthened by means of concrete structures. These successive barriers are mutually reinforcing and together ensure that wastes can be contained over the very long term. The waste can be recovered during the initial

phase of the repository, and also during subsequent phases, albeit at increased cost. This provides freedom of choice to future generations to change waste management strategies if they wish.

Repositories are designed so that no radioactivity reaches the Earth's surface. Following the precautionary principle, environmental impact assessments spanning 10,000 years analyse worst-case scenarios, including geological and climate changes and inadvertent human intrusion. The assessments maintain that even under those conditions, the impact on the environment and mankind would be less than current regulatory limits, which in turn are lower than natural background radiation.

Cost is an important issue in radioactive waste management as related to sustainable development. In organization for economic co-operation and development (OECD) countries, the costs of dismantling nuclear power plants and of managing long-lived wastes are already included in electricity generating costs and billed to end consumers. Although quite high in absolute terms, these costs represent a small proportion (less than 5%) of the total cost of nuclear power generation.

Deep geological disposal allows present generations to progress without leaving burdens for those of the future, but a main weakness is that although the concept is technically sound, it is rarely socially or politically accepted. The issue is not so much about information provision as understanding the mechanisms that govern the social perceptions of risk.

There are many factors that affect such perceptions, such as:

- Familiarity with the technology
- The degree of uncertainty
- The level of control
- Concern for the consequences
- The degree of credibility of the institutions
- The decision-making process and
- The ideas and values of the community in which people live.

Addressing the public's concern and negotiating acceptable solutions is an important challenge. A decision-making process should be set up step by step, and all the affected groups should be allowed to participate. The role of governments will be crucial in defining this process, and they should act as a source of objective information. They also need to dedicate adequate resources for this purpose, so that public confidence may be won in the scientific solutions being proposed.

Thus, if the effect caused by nuclear radiations could be controlled, the electricity produced by nuclear power would be cheaper compared to that from hydro-electric powers.

This cross-cutting issue can be addressed to students at the end of applications of nuclear fission and nuclear fusion (**student's book, unit 15 section 15.7.2**).

Standardization culture

Some materials used at home and in different institutions, especially at hospital, are radioactive or contaminated with radioactive substances. Thus, there must be regular measures to check the standard of any material before use.

The goal of much of radiobiology research is to establish the relationship between radiation dose and the magnitude of the effect of that dose. This is particularly a concern when there is a steep dose-response relationship, when data among different laboratories is to be compared, and when researchers try to repeat experiments.

Concerning the use of radiation that might be present in materials used at home, care should be taken especially by monitoring the hygiene of materials used and food stuffs.

This cross-cutting issue can be addressed to students in the introduction of unit 15 and/or while teaching the uses of radioisotopes as well as their health hazards (**student's book, unit 15 section 15.6 and 15.8 respectively**) just at the same time as when you addressing environment and sustainability cross-cutting issue.

Inclusive education

This unit requires learners to carry out a lot of researches to be able to understand first, then share and discuss on things like radioactive emissions, stability and instability of atoms, health hazards of radioactive substances, uses of radioisotopes, and so on. This may be challenging to students with special educational needs especially slow learners. However, as teacher you can organize your class and use different strategies to help all learners understand well. Some of the strategies to be used are provided below:

- Be patient! If you find that the student takes longer than others to learn or to do an activity, allow more time.
- Do activities together with the student.
- Gradually give the student less help.
- Let the student do the activity with his colleagues and encourage them to help each other.
- Divide the activity into small achievable steps.
- Remember to praise and say 'Well done' when the student learns something new or makes a strong effort.

This cross-cutting issue can be addressed at the beginning, during the teaching process or at the end of the teaching process of any lesson by providing extra-activities to both slow learners and gifted ones. Some activities are provided in the additional activities but you can also prepare more exercises to meet your learning objectives as a teacher.

15.4. Guidance on the introductory activity:

Introductory activity:

Radioactivity seems to be new for students but they are familiar

So, the introduction of this unit to students of senior six would simple. The introductory activity can attract interest of students as it is built on the materials that are around everywhere.

Here is a guide of how this activity can be performed by students guided by the teacher.

- Start by asking some or all of the four questions above the illustrations provided. Do not take much time here as the purpose of these questions is to create the curiosity of students about the unit! So, you better concentrate on the next steps.
- Put your students in groups of 3-4(or even 5 depending on the size of your class)
- Provide them with books or worksheets with the introductory activity, unit 15 from student's book S6.
- Give them time between 15 and 20 minutes to read, analyze, interpret and discuss about the activity. Here they have to observe and analyse the objects in the illustrations and discuss about the 4 points provided below the drawings. Let them use books or search from internet in order to discover what they don't discover directly.
- Call one or two groups to present their findings. You may note some key points at this stage.
- Ask other members (randomly) to give their input. Don't worry if some of them fail to reach the exact results. They will understand everything later as the unit progresses.
- Address your views about their presentations. But it is not necessary to conclude. Just motivate them and rise their curiosity. Normally

The following are some of the issues that may be risen up by students through their discussions on the points provided in student's book of senior six:

Point 1:

No, we cannot see or feel the presence of radiation. But it can be detected and measured in the minute quantities with quite simple radiation measuring instruments.

Sunlight feels warm because our body absorbs the infra-red rays it contains. But, infra-red rays do not produce ionization in body tissue. In contrast, ionizing radiation can impair the normal functioning of the cells or even kill them. The amount of energy necessary to cause significant biological effects through ionization is so small that our bodies cannot feel this energy as in the case of infra-red rays which produce heat.

Point 2:

High-energy ultra-violet radiation (UV), X-rays, gamma rays and nuclear alpha and beta radiation are different forms of ionizing radiation.

Examples of non-ionizing radiation are radio waves, radar, microwaves, infrared (heat) radiation and visible light.

We are surrounded by naturally-occurring radioactive elements in the soil and stones, and are bathed with cosmic rays entering the earth's atmosphere from outer space.

We receive internal exposure from radioactive elements which we take into our bodies through food and water, and through the air we breathe. In addition, we have radioactive elements (Potassium-40, Carbon-14, and Radium-226) in our blood or bones.

Additionally, we are exposed to varying amounts of radiation from sources such as dental and other medical X-rays, industrial uses of nuclear techniques and other consumer products such as aluminum wrist watches, ionization smoke detectors, etc. We are also exposed to radiation from radioactive elements contained in fallout from nuclear explosives testing, and routine normal discharges from nuclear and coal power stations.

Point 3:

Radioactive materials: these are materials that contain radioactive atoms (unstable atoms that emit radiation to become stable).

We live in a sea of radiation, and benefit from many forms of radiation in our everyday lives, including from radio waves, microwaves, visible light and x-rays. Radiation can be harmful, especially when we are exposed to too high doses and/or for too long, for example to x-rays and nuclear radiation.

Different forms of radiation are defined by the energy, i.e. how low or high the energy is, and the type, i.e. whether it is in form of electromagnetic waves or subatomic particles.

Radioactive radiation is high-energy radiation that has many useful applications. However, it can also cause damage to materials and to the human body. Whether or not radioactive radiation is dangerous depends on the type of radiation emitted by the radioactive source. The distance to the radioactive source and the duration of exposure to the radiation determine how dangerous it is. The same applies to the sun's rays.

Many forms of radiation are beneficial and essential to our survival. Some types of radiation can be hazardous and therefore pose risks to people. Two examples of high-energy potentially hazardous radiation are x-rays and nuclear radiation emitted by radioactive materials.

15.5. List of lessons/sub-heading

#	Lesson title	Learning objectives	Number of Periods
1	Introductory activity	Create curiosity about radioactivity.	1
2	Definition of radioisotopes and radioactivity and comparison between chemical and nuclear reactions	<ul style="list-style-type: none">• Explain the process of radioactivity.• Compare and contrast chemical and nuclear reactions.	2
3	Radioactive emission of alpha, beta and gamma rays, their properties and effect of electric and magnetic fields on radioactive rays	<ul style="list-style-type: none">• Explain the properties of alpha, Beta and Gamma rays.• Predict the types of radioactive particles based how they are deflected by the magnetic and electric fields	3
4	Nuclear equations and radioactive decay series	Write and balance nuclear reaction equations.	2
5	Stability and instability of nuclei of atoms	Explain the instability of radioisotopes based on their nuclear composition.	1
6	Rate of decay of radioactive substances and Half-life of radioactive substances and calculations involved	<ul style="list-style-type: none">• Perform calculations involving the radioactive constant, and activity of radioactive substances.• Explain half-lives of radioactive isotopes/radioisotopes.• Perform calculations involving the half- life of radioactive substances.	3

7	Uses of some radioisotopes	<ul style="list-style-type: none"> • Explain the applications of radioisotopes in medicine, agriculture and industries. • Apply the calculations of half-life to determine the age of fossils. 	2
8	Fission and fusion and their applications	Appreciate the use of nuclear fission and fusion in production of energy	1
9	Health hazards of radioactive substances	Develop awareness of the dangers of radioactive substances and nuclear weapons.	1
10	Summative assessment	Perform every exercise about this unit	2

Lesson 1: Definition of radioisotopes and radioactivity and comparison of nuclear and chemical equations

a. Prerequisites/Revision/Introduction:

Students will learn better this lesson if they have knowledge about isotopes of elements in the first unit of senior four, atomic structure and chemical reactions and equations.

b. Teaching resources

Use periodic table of elements, worksheets or books; projectors and/or chalkboard.

c. Learning activities

Defining radioactivity by students would seem to be complicated, but as long as they carried out discussions in introductory activity, they might have met this definition. For radioisotopes it would be simple since they are related to the term “isotopes”. Concerning the comparison between chemical and nuclear equations, students have enough knowledge on chemical equations. Starting from that you can help them to compare them successfully.

Methodological steps:

As a facilitator, you are expected to guide students to learn by doing activity 15.1, as described below:

Activity 15.1, student's book S6

Task one (this concerns question 1)

- Guide students to answer question number one by asking them randomly. They should be ready to answer as they did something about them in the introductory activity.
- The following are the expected answers

a) **Radioactivity** is the release of energy and matter due to a change in the nucleus of an atom.

Radioisotopes are isotopes that are unstable and release radiation.

All isotopes are not radioisotopes.

b)

- A nuclear equation involves protons and neutrons in the nucleus while the chemical equation involves outermost shell electrons.
- A nuclear equation produces an element which is different from the element in the reactant side while a chemical equation produces atoms of elements that are in the reactants
- Etc

Task 2 (Research):

- Put your students in groups of 3-4 members.
- Give your students time between 25 and 30 minutes to read and analyze the summary (about radioactivity and radioisotopes) in the student's book, or any other way (work sheet, projection, books from library, internet ...) you may have prepared for them.
- Call two or 3 groups (or more depending on your time) to present their findings. During the presentation, remember to take notes on some key points (correct ones and wrong ones) that are going to guide you in the next step.
- Ask members of other groups to give their comments/ inputs if any.
- Based on learners' production, through questioning, guide them to draw important conclusions. In your comments make sure that this topic in unit 15. So, this section serves as the introduction to the other sections in this unit!
- End up with checking up 15.1, in student's book as evaluation or homework.

Answers to checking up 15.1, student's book S6

1. a) **Radioactive decay** is the process by which an unstable atomic nucleus loses energy (in terms of mass in its rest frame) by emitting radiation, such as an alpha particle, beta particle with neutrino or only a neutrino in the case of electron capture, gamma ray, or electron ...

b) **Daughter nuclide** is the remaining nuclide left over from radioactive decay.

c) **Transmutation** is the change of one chemical element into another

2. **Radioisotopes are very unstable and contain high levels of nuclear energy and emit this energy in the form of nuclear radiation i.e, they are naturally radioactive whereas isotopes are not.**

The main difference is that isotopes can be either stable or unstable, but Radioisotopes are always unstable.

3. a) Chemical reaction.

b) Nuclear reaction

c) Nuclear reaction

d) Chemical reaction

Lesson 2: Radioactive emission of alpha, beta and gamma rays, their properties and effect of electric and magnetic field on these particles

a. Prerequisites/Revision/Introduction:

Students will learn better this lesson if they have knowledge about the use of periodic table in finding the position of elements when the atomic number is known; mass number and atomic number as discussed in unit one of senior four and forces that exist between charged particles as discussed in chemical bonding (unit 3&4 of senior four).

b. Teaching resources

Use periodic table of elements, worksheets or books; projectors and/or chalkboard.

c. Learning activities

Hopefully, students can state the three main particles emitted by radioactive isotopes. In this activity, as a teacher you have to guide them to go through and learn more about their origin, properties and how they can be employed in nuclear equations. Thus, in this point try to make sure that you help each student to do this as something that can make him/her feel proud of the chemistry he/she learnt as the subject of his/her choice.

Methodological steps:

As a facilitator, you are expected to guide students to learn by doing activity 15.2, as described below:

Activity 15.2, student's book S6

Task one (this concerns question 1)

- Guide students to answer question number one by asking them randomly.
- The following are the expected answers:

The three main types of radiation are: Alpha, Beta and Gamma

Task 2 (Research):

Use the same instructions as in activity 15.1 above.

The exception here is that this lesson has more number of periods (three periods of 120 minutes)! So the students should be given enough time for research (between 35-40 minutes) and you also need that enough time to hear from them and guide them to acquire what is important in this topic.

Here, you have to emphasize on the nuclear changes (i.e, change in protons and neutrons/ atomic and mass numbers) that accompany the emission of these radiation particles.

If possible you may come up with a video downloaded from www.youtube.com about the effect of electric and magnetic fields on the alpha particles, beta particles and gamma rays to help them understand clearly the properties of these particles.

This video can be projected when you are commenting on the findings presented by the students

As in activity 15.1, this lesson can be ended by checking up 15.2 as evaluation or homework (if you do not have enough time at the end of the lesson)

Answers to checking up 15.2, student's book S6

1. Both an alpha particle and a helium nucleus have 2 protons and 2 neutrons. However, an alpha particle is emitted from a nucleus during radioactive decay.
2. a) ${}_{19}^{39}K$, ${}_{19}^{40}K$ and ${}_{19}^{41}K$
b) They all have 19 protons and 19 electrons, but they differ in the number of neutrons.

3.

Medical use	Atomic symbol	Mass number	Number of protons	Number of neutrons
Heart imaging	$^{201}_{81}\text{Tl}$	201	81	120
Radiation therapy	$^{60}_{27}\text{Co}$	60	27	33
Abnormal scan	$^{67}_{31}\text{Ga}$	67	31	36
Hyperthyroidism	$^{131}_{53}\text{I}$	131	53	78
Leukaemia treatment	$^{32}_{15}\text{P}$	32	15	17

4. **Beta particles are fast moving electrons with a very low mass and so have a high charge to mass density.** They are deflected much more than the heavier alpha particles.

5. See student's book.

Lesson 3: Nuclear equations and radioactive decay series

a. Prerequisites/Revision/Introduction:

Students will learn better this lesson if they have knowledge about chemical equations, atomic and mass numbers.

b. Teaching resources

Use periodic table of elements, worksheets or books; projectors and/or chalkboard.

c. Learning activities

Nuclear equations and radioactive decay series are among simple activities that can be performed successfully by students. What is necessary here for them is to have knowledge on the properties of alpha particle and beta particle as well as their atomic and mass numbers.

Methodological steps:

As a facilitator, you are expected to guide students to learn by doing activity 15.3, as described below:

Activity 15.3, student's book S6

1. Chemical equations are balanced by making the number of atoms of elements present on the reactant side equal to the number of atoms of elements present on the products side. On the other hand, a nuclear equation is balanced by making the sum of atomic numbers and that of mass numbers of particles present on the left side equal to those present on the right side.

2. Task one (this concerns question 2)

- Guide students to answer question number one by asking them randomly. This like the revision of what they saw in 15.2. If students seem to be confused let them carry out their research first.

- The following are the expected answers:

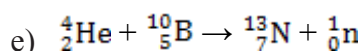
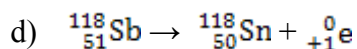
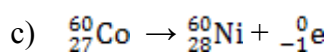
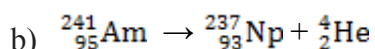
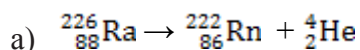

Task 1 (Research in case question number 2 seems to be complicated for your students):

Use the same instructions as in activity 15.1 above.

Here, you have to emphasize on how to balance nuclear equations by making the sum of atomic numbers and the sum of mass numbers of reactants equal to the sums of their counterparts in products.

As in all activities above, this lesson can be ended by checking up 15.3 as evaluation or homework (if you do not have enough time at the end of the lesson)

Answers to checking up 15.3, student's book S6

1. a) ${}_{13}^{28}\text{Al} \rightarrow {}_{14}^{28}\text{Si} + {}_{-1}^0\text{e}$
 - b) ${}_{36}^{87}\text{Kr} \rightarrow {}_{36}^{86}\text{Kr} + {}_0^1\text{n}$
 - c) ${}_{83}^{210}\text{Bi} \rightarrow {}_{81}^{206}\text{Tl} + {}_2^4\text{He}$
 - d) ${}_{18}^{40}\text{Ar} + {}_2^4\text{He} \rightarrow {}_{19}^{43}\text{K} + {}_1^1\text{H}$
 - e) ${}_{92}^{238}\text{U} + {}_0^1\text{n} \rightarrow {}_{92}^{239}\text{U}$
2. ${}_{27}^{60}\text{Co} \rightarrow {}_{28}^{60}\text{Ni} + {}_{-1}^0\text{e}$
 3. ${}_{30}^{66}\text{Zn} + {}_1^1\text{H} \rightarrow {}_{31}^{67}\text{Ga}$

4.

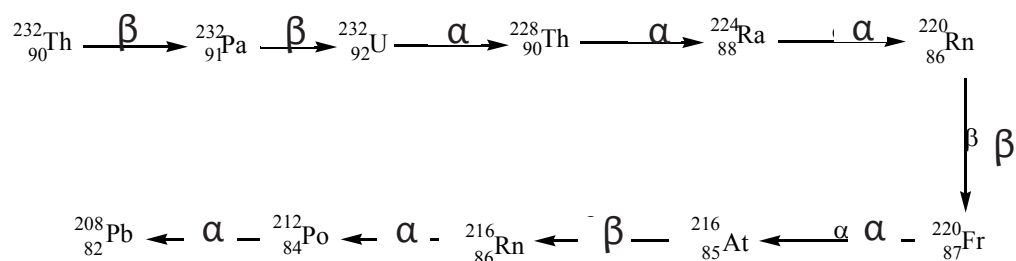

Lesson 4: Stability and instability of nuclei of atoms

c. Prerequisites/Revision/Introduction:

Students will learn better this lesson if they have knowledge about sub-atomic particles with their properties as discussed in unit one of senior four, atomic structure.

d. Teaching resources

Use periodic table of elements (very important), worksheets or books; projectors and/or chalkboard.

e. Learning activities

The stability of nuclei of atoms is one of simple activities that can be performed successfully by students. The necessity here is to have knowledge on constituent particles of the nucleus.

Methodological steps:

As a facilitator, you are expected to guide students to learn by doing activity 15.4, as described below:

Activity 15.4, student's book S6

Task one (this concerns question 1)

- Guide students to answer question number one by asking them randomly.
- The following are the expected answers:

The two main factors that determine nuclear stability are the neutron/proton ratio and the total number of nucleons (protons and neutrons) in the nucleus.

Task 2 (Research):

Use the same instructions as in activity 15.1 above.

The exception here is that this lesson has one period of 40 minutes! So the students should be given a short time for research so as for you to have enough time to hear from them and guide them to acquire what is important in this topic.

The large number of protons and neutrons in the nucleus is the origin of instability of some isotopes. This should be stressed in this lesson

As in activity 15.1, this lesson can be ended by checking up 15.4 as evaluation.

Answers to checking up 15.4, student's book S6

1. See the provided answer for activity 15.2 above
2. a) Elements with atomic number less than 20. For example, O ($z = 8$), Na ($z = 11$) ...
b) Elements with atomic number greater than 83. For example, Rn ($z = 86$), Am ($z = 95$) ...
c) Elements with atomic number between 20 and 83. For example, Co ($z = 27$), Tc ($z = 43$) ...

Lesson 5: Rate of decay and half-life of radioactive substances

a. Prerequisites/Revision/Introduction:

Students will learn better this lesson if they have knowledge about order of reaction and rate law from unit 14 senior six book.

b. Teaching resources

Worksheets or books; projectors and/or chalkboard.

c. Learning activities

Students should perform this activity very easily because the rate of decay as well as half-life of radioactive isotopes are given by the same expression as the one used to calculate the rate of a first order reaction.

Methodological steps:

As a facilitator, you are expected to guide students to learn by doing activity 15.5, as described below:

Activity 15.5, student's book S6

Task one (this concerns question 1)

- Guide students to answer question number one by asking them randomly. This is like a revision of some issues about the rate of reactions discussed in the previous unit.
- The following are the expected answers:
 - a. Average rate, R is given by:

$$R = \frac{\text{change in concentration}}{\text{time}} = \frac{0.300 - 0.292}{6.67 \times 10^{-5} \text{ mol dm}^{-3} \text{ s}^{-1}} = \frac{120}{6.67 \times 10^{-5} \text{ mol dm}^{-3} \text{ s}^{-1}}$$

- b. Time taken by reaction A = 2 x 60 + 35 = 155 sec

Time taken by reaction B = 1 x 60 + 15 = 75 sec

Let R_A be the rate for reaction A and Let R_B the rate for reaction b

$$R_A = \frac{1}{T} = \frac{1}{155} = \frac{1}{T} = \frac{1}{155} \text{ s}^{-1} \quad \text{and} \quad R_B = \frac{1}{75} = \frac{1}{75} \text{ s}^{-1}$$

$$\text{Now, } \frac{R_A R_A}{R_B R_B} = \frac{\frac{1}{155} \frac{1}{155}}{\frac{1}{75} \frac{1}{75}} = \frac{75}{155} = 0.484 \frac{75}{155} = 0.484$$

- c. **The half- life of a radioisotope** is the time taken for half of its nucleus to decay.

Task 2 (Research):

Use the same instructions as in activity 15.2 above.

Here, everything is obvious because students have already learnt the determination of rate of chemical reactions. But still you need to hear from their presentations carefully in order to guide them in a good manner.

As in all activities above, this lesson can be ended by checking up 15.5 as evaluation or homework.

Answers to checking up 15.5, student's book S6

1. a) $R = 3.0 \text{ Ci} = 3.0 \times 3.7 \times 10^{10} = 1.11 \times 10^{11}$ disintegrations /s
Time, $t = 20 \text{ s}$ Number of disintegrations = $1.11 \times 10^{11} \times 20 = 2.22 \times 10^{12}$ disintegrations

b) Rate per mass = $4.20 \mu\mu\text{Ci/kg}$ mass, $m = 70.0 \text{ kg}$ and thus,

$$\text{Rate, } R = 4.20 \times 70 = 294 \mu\mu\text{Ci}$$

2. $R_0 = 15.3 \text{ disintegration min}^{-1} \text{ g}^{-1}$ of C

$$R = 6.5 \text{ disintegration min}^{-1} \text{ g}^{-1} \text{ of C}$$

$$\lambda = 1.21 \times 10^{-4} \text{ min}^{-1}$$

$$\ln \frac{R_0}{R} = \lambda t$$

$$\ln = \frac{15.3}{6.5} = 1.21 \times 10^{-4} t$$

$$0.856 = 1.21 \times 10^{-4} t$$

Thus, $t = 7074.8$ minutes

3. Half-life is the time it takes for one half of a radioactive sample to decay. *Radioisotopes with short half-lives decay away soon after imaging is completed and hence cause minimal damage to the organ concerned.*

4. $t_{1/2} = 4.468 \times 10^9 \text{ years}$

$$\lambda = \frac{\ln 2}{t_{1/2}} = \frac{0.693}{4.468 \times 10^9} = 1.55 \times 10^{-10} \text{ year}^{-1}$$

$$\lambda = \frac{\ln 2}{t_{1/2}} = \frac{0.693}{30} = 0.0231 \text{ year}^{-1} \text{in}^{-1} \text{ and } R = 17 \text{ counts min}^{-1}$$

$$\ln \frac{R_0}{R} = \lambda t \ln \frac{R_0}{R} = \lambda t$$

$$\ln \frac{544}{17} = 0.0231 \times t$$

$$3.466 = 0.0231 t$$

Thus, $t = 150 \text{ years}$ and $2011 + 150 = 2161$

And therefore, the decay rate will be 17 counts per minute in 2161.

Lesson 6: Uses of some radioisotopes

a. Prerequisites/Revision/Introduction:

Students will learn better this lesson if they have knowledge about reaction kinetics (unit 13&14), calculations involved in the rate of reactions and rate of decay.

b. Teaching resources

Worksheets or books; projectors and/or chalkboard.

c. Learning activities

Students have to think critically to guess some uses of radioactive materials and carry out research to reinforce their prior knowledge.

Methodological steps:

As a facilitator, you are expected to guide students to learn by doing activity 15.6, as described below:

Activity 15.6, student's book S6

Task one (this concerns question 1)

- Guide students to answer question number one by asking them randomly.
- The following are the expected answers:

Radioactivity is used in medical examinations (such as X-rays) and nuclear power plants.

Radioactive substances and radiations are also used to sterilize food, prolong its shelf life, and prevent fires in public places...

Task 2 (Research):

Use the same instructions as in activity 15.1 above.

As in all activities above, this lesson can be ended by checking up 15.6 as evaluation or homework (if you do not have enough time at the end of the lesson).

Answers to checking up 15.6, student's book S6

1. A tracer is a radioactive isotope that can be detected far from its original source to trace the

path of certain chemicals. Hydrogen-3 can be used to trace the path of water underground.

2. If the initial amount of a radioactive isotope is known, then by measuring the amount of the isotope remaining, a person can calculate how old that object is since it took up the isotope.

3. Carbon-14, Hydrogen-3, Cesium-137...

4. $R_0 = 14.0 \text{ Bq}$, $R = 3.5 \text{ Bq}$ and $t_{1/2} t_{1/2} = 5730 \text{ years}$

$$\lambda = \frac{\ln 2}{t_{1/2}} = \frac{0.69314718}{5730} = 0.000121 \text{ year}^{-1}$$

$$\ln \frac{N_0}{N} = \lambda t \ln \frac{N_0}{N} = \lambda t$$

$$\ln \frac{14}{3.5} = 0.0001209681 \times t$$

$$1.3863 = 0.0001209681 \times t$$

Thus, $t = 11460$ years

Therefore, this wood sample is 11460 years old.

5.

- The elements calcium and phosphorus are part of bone. So, their radioactive isotopes will also become part of the bony structures of the body where their radiation can be used to diagnose or treat bone diseases.
- Strontium acts much like calcium because they belong to the same group (group II) in the periodic table. The body will accumulate radioactive strontium in bones in the same way that it incorporates calcium. However, radioactive strontium is harmful to children because the radiation it produces causes more damage in cells that are dividing rapidly.

Lesson 7: Fission and fusion and their applications

a. Prerequisites/Revision/Introduction:

Students will learn better this lesson if they have knowledge about chemical reactions in general, chemical energetics; nuclear equations and decay series.

b. Teaching resources

Use periodic table of elements, worksheets or books; projectors and/or chalkboard.

c. Learning activities

Guide students to explain nuclear fission and fusion as well as their applications.

Methodological steps:

As a facilitator, you are expected to guide students to learn by doing activity 15.7, as described below:

Activity 15.7, student's book S6

1. Task one (this concerns question 1)

- Guide students to answer question number one by asking them randomly.
 - The following are the expected answers:
- Fission is the splitting of a heavy, unstable nucleus into two lighter nuclei while fusion is the process where two light nuclei combine together releasing large amount of energy.

Refer to student's book

3.Task 2 (Research):

Use the same instructions as in activity 15.4 above.

Here, you have to emphasize on loss in mass as both processes take place and this mass is converted into energy. So make sure that, by the end of this lesson, your students are able to apply Einstein's equation to calculate the nuclear energy.

As in all activities above, this lesson can be ended by checking up 15.7 as evaluation or homework (if you do not have enough time at the end of the lesson)

Answers to checking up 15.7, student's book S6

1. a) Fusion

b) Both fusion and fission

c) Fusion

2.

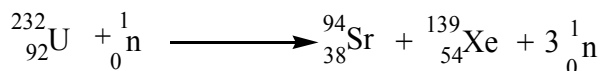

Lesson 8: Health hazards of radioactive substances

a. Prerequisites/Revision/Introduction:

Students will learn better this lesson if they have knowledge about reaction kinetics (unit 13&14).

b. Teaching resources

Worksheets or books; projectors and/or chalkboard.

c. Learning activities

Students have to think critically to guess some risks caused by radioactive materials and carry out research to reinforce their prior knowledge.

Methodological steps:

As a facilitator, you are expected to guide students to learn by doing activity 15.8, as described below:

Activity 15.8, student's book S6

Task one (this concerns question 1)

- Guide students to answer question number one by asking them randomly.
- The following are the expected answers:

Ionizing radiation can affect the atoms in living things, so it poses a health risk by damaging tissue and DNA in genes. In most cases, a large acute exposure to radiation causes both immediate (radiation sickness) and delayed effects (cancer or death), can cause sickness or even death within hours or days.

Task 2 (Research):

Use the same instructions as in activity 15.4 above.

As in all activities above, this lesson can be ended by checking up 15.5 as evaluation or homework (if you do not have enough time at the end of the lesson).

Answers to checking up 15.8, student's book S6

1. - **Earth itself is a source of terrestrial radiation.**
 - Radioactive materials (including uranium, thorium, and radium) exist naturally in soil and rock.
 - Air contains radon, which is responsible for most of the dose that people receive from natural background sources.
2. The signs and symptoms of acute radiation poisoning are:
 - Vomiting, diarrhea, and nausea.
 - Loss of appetite.
 - Malaise or feeling unwell.
 - Headache.
 - Rapid heartbeat.

15.6. Summary of the unit

Radioactivity or radioactive decay is the spontaneous process by which an unstable atomic nucleus changes into another more stable atomic nucleus by emitting energy in form of radiation.

Radioactive substances (with unstable nuclei) also known as **parent nuclides** disintegrate/decay to form substances (with stable nuclei) known as **“the daughter nuclides”**.

The instability in the nucleus of an atom is caused by a great number of protons and neutrons present in it due to the repulsion forces between the protons, hence resulting in transformations that lead to the formation of a stable nucleus by emitting radiations.

The symbols for the main radiations (or particles) emitted by unstable nuclei to become stable are given below:

Alpha particle = ${}^4_2\text{He}$ or $(\frac{4}{2}\alpha)$, beta particle = ${}_{-1}^0\beta$ (or -1^0e), gamma radiation = ${}^0_0\gamma$

Proton = ${}^1_1\text{p}$ (or ${}^1_1\text{H}$), neutron = ${}^1_0\text{n}$, positron = ${}^0_{+1}\beta$ (or $+1^0e$)

Nuclear equations involve both the parent and daughter nuclides and particles emitted (or used for bombardment of the nucleus). A nuclear equation is balanced when the sum of mass numbers and the sum atomic numbers on the left hand side are equal to the sums of those on the right hand side of the equation.

Unlike chemical equations, nuclear equations involve the atoms of elements present in products which are different from those in reactants. In nuclear equations, there is also a small mass (Δm) lost which is converted into nuclear energy. This energy can be calculated using Einstein's equation, $E = \Delta m \times c^2$.

The following table summarizes the types of radioactive decays and the changes that take place when the decay reaction is presented as a nuclear equation.

Type of Decay	Radiation	Nuclear Change		Type of Nuclide
		Atomic No.	Mass No.	
Alpha emission	${}^4_2\text{He}$	-2	-4	heavy isotopes, $Z > 83$
Beta emission	${}^0_{-1}\text{e}$	+1	0	n/p ratio too large
Positron emission	${}^0_{+1}\text{e}$	-1	0	n/p too small ($Z < 30$)
Electron capture	X-rays	-1	0	n/p too small ($Z > 30$)
Gamma emission	γ	0	0	excited nucleus

Radioactive materials decay by first-order rate law:

$$\ln \frac{N}{N_0} = -\lambda t \quad (N_0 = \text{activity at time } t = 0 \text{ and } N = \text{activity at time } t)$$

The above expression is equivalent to

$$\ln \frac{N_0}{N} = \lambda t$$

And can be used to work out the decay constant, λ , the time, t , as well as the fraction, $\frac{N}{N_0}$, of the initial sample of radioactive material left after a given time. Of course,

$$\frac{N}{N_0} = e^{-\lambda t}$$

And from the latter expression you can calculate the number of nuclides, N , remaining after a given time has passed. You can even work out the activity of the initial sample, N_0N_0 , once you are provided with the actual number of nuclides (N) at the very given time.

The half-life, $t_{1/2}$, of the radioisotope is the time taken for half of its sample to decay. This half-life is related to the decay constant by the following expression:

$$t_{1/2} = \frac{\ln 2}{\lambda} = \frac{0.69315}{\lambda}$$

This expression can be the basis for all calculations involved in the radioactive decays in which one of the half-life or radioactive constant is given.

Nuclear fission is the splitting of a heavy, unstable nucleus into two lighter nuclei while **nuclear fusion** is the process where two light nuclei combine together releasing large amounts of energy.

Both fission and fusion are nuclear reactions that produce energy which can be used in nuclear power plants.

Radioactive isotopes have a variety of applications. Generally, they are useful because either we can detect their radioactivity or we can use the energy they release.

Radioactivity plays an important role in medicine, agricultural processes and industry for radioactive dating where the age of an archeological artifact or rock can be determined by referring to the half-life of the radioisotope (such as carbon-14 or uranium-238 respectively) present in it.

Besides positive applications of radioisotopes, however, it was found that continuous, high exposure to nuclear radiations lead to radiation risks like lung cancer and eventually to death.

15.7. Additional information for teachers

Radioactivity surrounds us

All the energy we get from the sun comes from one comparatively simple reaction: the fusion of two hydrogen nuclei into another, heavier nucleus. This reaction, involving the same forces as those responsible for beta radioactivity, is what has allowed elements other than hydrogen to be generated.

Without radioactivity, our planet would have frozen over long ago and life on Earth would be impossible. Radioactive processes in the Earth core slowly release the heat essential for our survival, constantly maintaining the temperate climate we take for granted. All life has developed in a constant shower of radiations, adapting to it and occasionally using it for its own benefit. Radiations are an omnipresent, inescapable feature of our lives. Whether we go on mountain-climbing expeditions, go down to the cellar to get a bottle of wine, or get aboard a plane, we will always be exposed to it.

Apart from the countless natural sources of exposure, the harnessing of radiation by humanity has led to a multitude of applications that we use every day. Even though the main artificially generated exposure comes from medical examinations (such as X-rays and gamma rays), we use radioactive substances and radiations to sterilize food, prolong its shelf life, and prevent fires in buildings.

We must not forget, however, that all these common sources of radiation, whether natural or artificial, remain virtually harmless. The two main sources of exposure to radiation are natural radioactivity and medicine. A third source is the exposure in case of accidents.

Activity

The activity of the sample of radioisotopes is measured in terms of the number of nuclear disintegrations per second. The **curie (Ci)** is the original unit of activity defined as the number of disintegrations that occur in one second for 1g of radium, which is equal to $3.7 \times 10^{10} \times 10^{10}$ disintegrations per second.

The curie was named for **Marie curie** (from Poland), who along her husband **Pierre**, discovered the radioactive elements **radium** and **polonium**.

Biological effect

After measuring the activity of a radioisotope, we need to know how much radiation absorbed by the tissues in the body. The **rad (radiation absorbed dose)** is the unit that measures the amount of radiation absorbed by one gram of material such as body tissue. The SI unit for absorbed dose is **gray (Gy)**, which is referred to as the energy, in joules, absorbed by 1 kg of the tissue. The gray is equal to 100 rads.

The **rem (radiation equivalent in humans)** measures the biological effects of different kinds of radiation. As seen in student's book, alpha particles do not penetrate the skin. But if they enter the body by any other route, they cause a lot of damage even though they travel a short distance in the tissue. High-energy radiation such as beta particles and high-energy protons and neutrons that penetrate the skin and travel into tissue cause more damage. Gamma rays also damage the tissue because they travel a long way through the tissue and create a great deal of ionization.

To determine the **equivalent dose or rem dose**, the absorbed dose (rads) is multiplied by a factor that adjusts for biological damage caused by a particular form of radiation.

Biological damage (rem) = absorbed dose (rad) $\times \times$ factor

Where,

Factor = 1 (for beta and gamma radiation).

Factor = 10 (For high-energy protons and neutrons)

Factor = 20 (for alpha particles)

The measurement for an equivalent dose is often in units of millirems (mrem, 1 rem =

1000 mrem). The SI unit is **sievert (Sv)**. One sievert is equal to 100 rems.

Table below summarizes some units of activity and the relationship between them.

Measurement	Common Unit	SI Unit	Relationship
Activity	Curie (Ci) = 3.7×10^{10} disintegration/s	Becquerel (Bq) = 1 disintegration/s	1 Ci = 3.7×10^{10} Bq
Absorbed Dose	rad	Gray (Gy) = 1 J/kg tissue	1 Gy = 100 rad
Biological Damage	rem = rad \times factor	1 sievert (Sv)	1 Sv = 100 rem

15.8. End unit assessment

Learning and assessment standards:

- Describe the nature of radioisotopes, emitted radiation, and emitted particles (alpha, beta and gamma). Selecting the most useful and efficient research methods for the tasks.
- Determine the rate of reaction in the decay of radioisotopes by selecting appropriate mathematical operations, measurements and calculations.
- Explain the importance and dangers of radioisotopes related to the nature of the radiation (alpha, beta, and gamma) and the half life of the radioisotopes, evaluating the usefulness and relevance of information from different sources.

Answers to End unit 15 assessment questions

I. MULTIPLE CHOICE QUESTIONS. Choose the letter corresponding to the appropriate answer

1. C
2. C
3. C
4. B
5. C
6. A
7. D
8. D
9. A
10. B

12. B
 13. C
 14. B
 15. D

II. Matching: Choose the letter of the correct word for each of the questions below. Each letter will be used only once.

- 1) G
 2) J
 3) B
 4) D
 5) I (or H)
 6) H (and J)
 7) E
 8) C
 9) A
 10) F

III. Short and long answer open questions

1. Radioactivity is the spontaneous emission of particles and electromagnetic radiation from nuclei of unstable atoms.

2. An alpha particle is a collection of two protons and two neutrons and is equivalent to a helium nucleus.

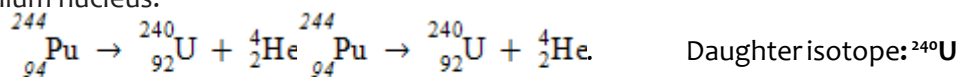

3.

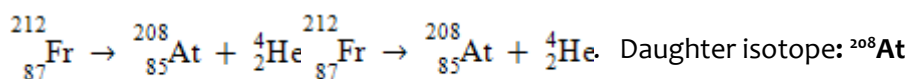

4.

b) $1/32$ (0.03125)

c) 22400 years

1. $t_{1/2} = 4.5 \text{b years}$ $t_{1/2} = 4.5 \text{b years}$ $t = 5.0 \text{b years}$

$$\lambda = \frac{\ln 2}{t_{1/2}} = \frac{\ln 2}{4.5} = \frac{0.69315}{4.5} = 0.154 \text{ year}^{-1}$$

$$\frac{N}{N_0} = e^{-\lambda t} = e^{-0.154 \times 5} = 0.463$$

This is the fraction of U-238 remaining.

The fraction of Pb-206 formed = $1 - 0.463 = 0.537$

$$\text{The ratio } {}^{238}\text{U}/{}^{206}\text{Pb} = \frac{0.463}{0.537} = 0.862 = \frac{862 \times 0.463}{1000 \times 0.537} = 0.862 = \frac{862}{1000}$$

Therefore, the rock contains 862 ${}^{238}\text{U}$ atoms for every 1000 ${}^{206}\text{Pb}$ atoms formed.

15.9. Additional Activities

Remedial questions

1. Write the isotope symbols for each of the following nuclides:

a) Carbon-14 (Answer: ${}^{14}_6\text{C}$)

b) Cobalt-60 (Answer: ${}^{60}_{27}\text{Co}$)

c) Lead-206 (Answer: ${}^{206}_{82}\text{Pb}$)

d) Radium-226 (Answer: ${}^{226}_{88}\text{Ra}$)

e) Uranium-238 (Answer: ${}^{238}_{92}\text{U}$)

f) Californium-251 (Answer: ${}^{251}_{98}\text{Cf}$)

2. Which penetrates matter more deeply: alpha particles or beta particles? Suggest ways to protect yourself against both particles.

Answer: Beta particles penetrate more. A thick wall of inert matter is sufficient to block both particles.

3. Tin has an atomic number of 50. Write the nuclear equation for the beta particle emission of tin-121. What is the daughter isotope?

Answer: ${}^{121}_{50}\text{Sn} \rightarrow {}^{121}_{51}\text{Sb} + {}^0_{-1}\text{e}$ ${}^{121}_{50}\text{Sn} \rightarrow {}^{121}_{51}\text{Sb} + {}^0_{-1}\text{e}$ **daughter isotope:** ${}^{121}\text{Sb}$

4. The half-life of cesium-137 is 30.2 years. How long will it take for a sample of cesium-137 to decay to 1/8 of its original mass?

Answer: 90.6 years

5. The half-life of strontium-90 is 28.1 years. How long does it take for a 10.0-g sample of ^{90}Sr to decompose to 0.10 g?

Answer: 187 years

Consolidation questions

1. Complete the following nuclear equations. Indicate the symbol, the mass number, and the atomic number of the unknown particle.



2. What are gamma rays?

Answer: Gamma rays are high-energy electromagnetic radiation given off in radioactive decay.

3. A radioactive isotope has a half-life of 56.6 days. What fraction of the isotope remains after 449 days?

Answer: 4.1×10^{-3} (almost 1/250)

4. Iodine-131 has a half-life of 8.0 days. If a person ingests 2.5 mg of NaI labeled with iodine-131, how much of the radioactive isotope remains in the body after 30 days?

Answer: 0.158 mg of Iodine-131 or 0.186 mg of Na^{131}I

5. Neutron activation analysis is an analytical technique in which a sample of material is bombarded with neutrons from a fission reactor. When a 35.0-g aluminium can is irradiated, it has an initial activity of 40.0 curies (Ci). The safety office won't let you touch anything having an activity in excess of 0.100 Ci. Assuming all the radioactivity is from ^{28}Al , which has a half-life of 2.28 min, how many minutes do you have to wait after bombardment before you can handle the can safely?

Answer: 19.7 min

Extended questions

1. Define *nuclear fission*:

Answer: Nuclear fission is the breaking down of large nuclei into smaller nuclei, usually with the release of excess neutrons.

2. Uranium-235 undergoes a series of decays that finally forms lead-207. How many α and β particles are produced in one decay series?

Answer: 7 α and 4 β

3. What is the age of a rock that contains equal numbers of ${}^{40}_{19}\text{K}$ and ${}^{40}_{18}\text{Ar}$ nuclei? The half-life of ${}^{40}_{19}\text{K}$ is 1.28×10^9 years.

Answer: 1.28×10^9 years

4. Fresh rainwater or surface water contains enough tritium (${}^3\text{H}$) to show 5.5 disintegration per minute (dpm) per 100.0 g of water. A vintage wine showed a tritium level of 0.50 dpm in 100.0 g of the wine sample. If the half-life of tritium is 12.3 years, estimate the age of the wine.

Answer: $42\frac{11}{22}$ years old at the time isotope analysis was done.

5. Suppose that a sample of a radioactive isotope contains 8.3 grams of the isotope after 1.2 days, and that after 7.3 days only 6.2 grams of the isotope remain.

a) Find the radioactive constant and its half-life

Answer: $\lambda = 0.04782 \text{ day}^{-1}$ $t_{1/2} = 14.5$ days

b) How much of the sample would you expect to be remaining after 10 days?

Answer: 5.45 g

c) How much of the sample were there initially (at $t = 0$ days)?

Answer: 8.8 g

REFERENCES

- Andrady A. L. and Neal M. A. (2009). Applications and societal benefits of plastics. *Phil. Trans. R. Soc. B* 364, 1977–1984
- Bahl, A. (2010). *Advanced Organic Chemistry*. S Chand & Company Limited.
- Briggs, J. (2002). *Level Course in Chemistry* (Illustrated, reprint ed.). Pearson Education South Asia.
- C., P., & H., P. (2014). *Combridge International AS and A level Chemistry*. London: HODDER Education.
- Chang, R. (2005). *Chemistry* (eighth ed.). McGraw-Hill.
- Harwood, William S., F. G. Herring, Jeffrey D. Madura, and Ralph H. Petrucci. *General Chemistry Principles and Modern Applications*, 9thed. New Jersey: Prentice Hall, 2007.
- H., R., & L., I. (2011). *Combridge IGCSE Chemistry Workbook* (Third edition ed.). New York: Combridge university press.
- Holman, G. H. (2000). *Chemistry in Context 5th Edition*. United Kingdom: Nelson Thornes.
- Huhs, P. C. (2002). *Chemistry for advanced level*. London: JOHN MURRAY.
- Hopewell, J., Dvorak, R., and Kosior, E. (2009). Plastics recycling: challenges and opportunities. *Philos Trans R Soc Lond B Biol Sci*; 364(1526): 2115–2126. doi: 10.1098/rstb.2008.0311.
- Jain, S., & Shailesh, K. *Chemistry Volume-I For Class XII*. S.Chand Publishing.
- Kasangandjo, L. (2013). *Advanced level Chemistry Students' Book for S6*. England: Pearson.
- Keith, J., & Sue, A. &. (2000). *Spotlight Science: Teacher Support Pack* (Illustrated, revised ed.). Nelson Thornes.
- Lister, T., & Renshaw. (1995). *Understanding Chemistry for Advanced Level* (second ed.). Stanley Thornes.
- Lister, T., & Renshaw, J. (2000). *New Understanding Chemistry for Advanced Level* (Illustrated ed.). Nelson Thornes.
- Lwishi, K. (2013). *Pearson Advanced level Chemistry Student's Book for S6*. Harlow: PEARSON.
- Moore, J. T. (2012). *Chemistry II For Dummies*. John Wiley & Sons.
- Negi, A., & Anand, S. (1985). *Textbook of Physical Chemistry* (Illustrated, reprint ed.). New Age International.
- NCERT. (2007). *Chemistry Part II Textbook for Class XII*. National Council of e.
- Obonyo, S.; Mukama, D. (2013). *Chemistry for Rwanda Secondary Schools Advanced level Senior 6*. Kampala: Fountain.

- Pavia, D. L. (2005). *Introduction to organic Laboratory Techniques: A Small Scale Approach* (Illustrated ed.). Cengage Learning.
- Peter, C., & H., P. (2014). *Cambridge International AS and A level Chemistry*. London: HODDER Education.
- Prakashan. (2006). Medical entrance examination student in India. *Competition Science Vision*, 8, 1537.
- Ramsden, E. (2000). *A level Chemistry* (Fourth Edition Ed.). United Kingdom: Nelson Thornes.
- Ramsden, E. (1995). *Calculations for A-Level Chemistry* (Illustrated ed.). Nelson Thornes.
- Ritchie, D. G. (2008). *OCR Chemistry A2*. Harlow: Heinemann.
- Satya Prakashh, G. T. (1999). *Advanced Inorganic Chemistry*. New Delhi: S. Chand & Company Ltd.
- Sinha, N. (2007). *Handbook of Food Products Manufacturing* (Vol. 2). John Wiley and Sons.
- Soffar, H. (2017, June 19). *Thermosets, Uses, features, Advantages and disadvantages*. Retrieved March 23, 2018, from <http://online-sciences.com>
- Stellman, J. M. (1998). *Encyclopedia of Occupational Health*. 3 Sarda, V., & Handa, A. & Chemistry. Saraswati House Pvt Ltd.
- Thompson, R.C., Moore, C.J., vom Saal, F.S. and Swan, S.H. (2009). Plastics, the environment and human health: current consensus and future trends. *Biol Sci.*, 364(1526): 2153–2166.