

# Chemistry

**Senior 3**

**Teacher's Guide**

**© 2024 Rwanda Basic Education Board (REB)**

All rights reserved.

This document is property of the government of Rwanda.  
Credit should be given to REB when the content is quoted.

# FOREWORD

Dear teacher,

Rwanda Basic Education Board is honoured to present Senior Three Chemistry Teacher's Guide which serves as a guide to competence-based teaching and learning to ensure consistency and coherence in the learning of the Chemistry subject. The Rwandan educational philosophy is to ensure that learners achieve full potential at every level of education which will prepare them to be well integrated in society and exploit employment opportunities.

In line with efforts to improve the quality of education, the government of Rwanda emphasizes the importance of aligning teaching and learning materials with the syllabus to facilitate their learning process. Many factors influence what they learn, how well they learn and the competences they acquire. Those factors include the relevance of the specific content, the quality of teachers' pedagogical approaches, the assessment strategies and the instructional materials available. We paid special attention to the activities that facilitate the learning process in which learners can develop ideas and make new discoveries during concrete activities carried out individually or with peers. With the help of the teachers, learners will gain appropriate skills and be able to apply what they have learnt in real life situations. Hence, they will be able to develop certain values and attitudes allowing them to make a difference not only to their own life but also to the nation.

This is in contrast to traditional learning theories which view learning mainly as a process of acquiring knowledge from the more knowledgeable who is mostly the teacher. In competence-based curriculum, learning is considered as a process of active building and developing of knowledge and understanding, skills and values and attitude by the learner where concepts are mainly introduced by an activity, situation or scenario that helps the learner to construct knowledge, develop skills and acquire positive attitudes and values.

In addition, such active learning engages learners in doing things and thinking about the things they are doing and they are encouraged to bring their own real experiences and knowledge into the learning processes. In view of this, your role is to:

- Plan your lessons and prepare appropriate teaching materials.
- Organize group discussions for learners considering the importance of social constructivism suggesting that learning occurs more effectively when the learner works collaboratively with more knowledgeable and experienced people.
- Engage learners through active learning methods such as inquiry methods, group discussions, research, investigative activities and group and individual work activities.

- Provide supervised opportunities for learners to develop different competences by giving tasks which enhance critical thinking, problem solving, research, creativity and innovation, communication and cooperation.
- Support and facilitate the learning process by valuing learners' contributions in the class activities.
- Guide learners towards the harmonization of their findings.
- Encourage individual, peer and group evaluation of the work done in the classroom and use appropriate competence-based assessment approaches and methods.

To facilitate you in your teaching activities, the content of this teacher`s guide is self-explanatory so that you can easily use it. Even though this teacher`s guide contains the answers for all activities given in the learner`s book, you are requested to work through each question and activity before judging learner`s findings.

I wish to sincerely extend my appreciation to REB staff who organized the editing process of this Teacher`s Guide. Special gratitude also goes to lecturers, teachers, illustrators and designers who supported the exercise throughout. Any comment or contribution would be welcome to the improvement of this textbook for the next edition.



**Dr. MBARUSHIMANA Nelson**  
**Director General, REB**

# ACKNOWLEDGEMENT

I wish to express my appreciation to all the people who played a major role in the editing process of this Chemistry Teacher's Guide for Senior Three. It would not have been successful without their active participation.

Special thanks are given to those who gave their time to read and refine this textbook to meet the needs of competence based curriculum. I owe gratitude to different universities and schools in Rwanda that allowed their staff to work with REB to edit this book. I therefore, wish to extend my sincere gratitude to lecturers, teachers, illustrators, designers and all other individuals whose efforts in one way or the other contributed to the success of this edition.

Finally, my word of gratitude goes to the Rwanda Basic Education Board's staff particularly those from the Curriculum, Teaching and Learning Resources Department who were involved in the whole process of editorial work.



**Joan Murungi,**  
**Head of CTRLRD**

# Table of Contents

Foreword .....	iii
Acknowledgement.....	v

## Part I: Introduction

<b>Section I: General Introduction.....</b>	<b>1</b>
1.1 Organisation of the book.....	1
1.2 Background information on new curriculum .....	3
1.3 Rationale of teaching and learning Chemistry .....	3
1.4 Types of competences and their acquisition.....	4
1.5 Cross-cutting issues to be infused during learning.....	6
1.6 Special needs education and inclusivity .....	9
1.7 Classroom organisation.....	11
1.8 Safety in the classroom .....	12
1.9 Assessment and evaluation methods .....	13
<b>Section 2: Content map .....</b>	<b>17</b>
<b>Section 3: Lesson plan .....</b>	<b>28</b>
3.1 Important sub-heading of a lesson plan .....	28
3.2 Sample competence-based lesson plan .....	29
3.3 Conclusion.....	33

## Part II: Units Section

<b>Unit 1 Carbon and its inorganic compounds.....</b>	<b>34</b>
1.1: Allotropes of carbon, their properties and uses.....	38
Answers to Test your Competence 1.....	56
<b>Unit 2 Nitrogen and its inorganic compounds .....</b>	<b>60</b>
2.1 Industrial isolation of nitrogen .....	64
2.2 Laboratory preparation of nitrogen.....	66
2.3 Preparation, properties and uses of nitrogen compounds.....	68
Answers to Test your Competence 2.....	83
<b>Unit 3 Sulphur and its inorganic compounds .....</b>	<b>87</b>
3.1 Occurrence and extraction of sulphur.....	91
3.2 Properties and uses of sulphur .....	92
3.3 Inorganic compounds of sulphur and their properties.....	94
3.4 Industrial preparation of sulphuric acid.....	96
Answers to Test your Competence 3.....	103

<b>Unit 4 Chlorine and its inorganic compounds.....</b>	<b>107</b>
4.1 Preparation and test for chlorine.....	111
4.2 Chemical properties and uses of chlorine .....	113
4.3 Compounds of chlorine .....	115
4.4 Tests for chlorides and other halides in solutions.....	118
Answers to Test your Competence 4.....	122
<b>Unit 5 Rate of reactions.....</b>	<b>125</b>
5.1 Effect of different conditions on rate and speed of reaction .....	129
Answers to Test your Competence 5.....	141
<b>Unit 6 Chemical properties of acids and bases .....</b>	<b>146</b>
6.1: Preparation of acids and bases .....	150
6.2: Reactions of acids and bases.....	151
6.3 Uses and dangers of acids and bases .....	153
Answers to Test your Competence 6.....	157
<b>Unit 7 Concentration of solutions .....</b>	<b>161</b>
7.1 Concept of concentration.....	165
7.2 Preparation of standard solutions .....	168
7.3 Acid – base titrations .....	170
Answers to Test your Competence 7.....	175
<b>Unit 8 Electrolysis and its applications.....</b>	<b>179</b>
8.1: Introduction to oxidation – reduction reactions .....	183
8.2: Electrolysis of solutions .....	185
8.3 Application of electrolysis .....	189
Answers to Test your Competence 8.....	193
<b>Unit 9 Structure and properties of alkenes and alcohols.....</b>	<b>198</b>
9.1: Nomenclature of alkenes and their structures .....	202
9.2 Preparation, properties and uses of alkenes .....	205
9.3 Nomenclature of alcohols and their structures .....	207
9.4 Uses and misuse of alcohol .....	212
Answers to Test your Competence 9.....	215
<b>Unit 10 Carboxylic acids .....</b>	<b>218</b>
10.1 General formula and nomenclature of carboxylic acids.....	221
10.2 Preparation of carboxylic acids .....	223
10.3 Preparation and uses .....	224
Answers to Test your Competence 10 .....	229
<b>Unit 11 Petroleum products and polymerisation.....</b>	<b>232</b>
11.1 Origin of crude oil and its fractional distillation .....	236
11.2 Polymers and polymerisation .....	237
11.3 Dangers associated with polymers .....	239
Answers to Test your Competence 11 .....	242
<b>Appendices.....</b>	<b>245</b>
<b>Periodic Table of Elements.....</b>	<b>248</b>

## 1.1 Organisation of the book

This teacher's guide is presented in **four** sections.

- **Section 1** - is the general introduction section detailing pedagogical issues.
- **Section 2** - is the the content map,
- **Section 3**- gives guidelines on how to develop a lesson plan and parts that constitute a competence-based lesson plan.
- **Section 4** - which is main topics area. It gives the details of the expected learning **units** as presented in the learner's book.

### Structure of a unit

The main elements of each unit are.

**Unit heading** – this is accompanied by some text in the student's book to motivate the learners. Also, the total number of lessons per unit is given.

- **Key Unit Competence:** This is the competence, which will be achieved once students have met all the learning objectives in the unit.
- **Pre-requisite of the unit:**  
This section details what is required to ensure success of the unit i.e what should be done for the key unit competence to be met.
- **Learning Objectives:** The content in this area is broken down into three

categories, that is, knowledge and understanding; skills; attitudes and values.

- *Knowledge and understanding:* As in the existing curriculum, knowledge and understanding is very important.
- *Skills:* It is through the skills that students apply their learning and engage in higher order thinking. These skills relate to the upper levels of Bloom's taxonomy and they lead to deep rather than surface learning.
- *Attitudes and values:* Truly engaging with learning requires appropriate attitudes and values that relate to the unit.
- **Links to other subjects:** It is important for learners to gain an understanding of the interconnections between different subjects so that learning in each subject is reinforced across the curriculum. This platform does exactly that. It prepares the teacher to pass this information to the learners so that they are aware!
- **Background information:** This is the introduction part of the unit. It aims at giving insights to the teacher on the subject matter.



- **Cross cutting issues** to be tackled in the unit and how to address them.
  - **Generic competences** to be attained by learners and how to develop them.
  - **Key words in the unit** – a list of new words or vocabularies and their meanings.
  - **Guidance on the problem statement:** This is given as ‘mind teaser’ in the student book. It highlights how the teacher should introduce the unit and create a problem situation for learners to brainstorm and predict what the unit is about.
  - **Attention to special needs education:** This section gives guidance on how to cater for multi-ability learning and how to support learner with special needs.
  - **List of lessons:** This section gives lesson number, title and number of periods expected to cover the lesson. Immediately after the list are the lessons themselves covered in detail per sub-topic.
- Summary of the unit** – This section details how the teacher will go about winding up unit. It also details the values and key competencies that the learner needs to achieve.
- **Additional information for the teacher**  
This is a platform where content related to the content areas being taught but not expressly within the syllabus requirements are presented. The content here is intended to help the teacher understand the concepts more deeply and be in a position to answer questions from more proactive learners.
  - **Answers to test your competence**  
This section provides answers to revision questions at end of the unit.
  - **Consolidation exercises**  
These are further exercises meant for additional assessment and which can also be given as home work. They can also help during remedial teaching and as further exercise for gifted learners.
  - **Additional activities for slow and gifted learners.**  
These are further exercises and their answers intended for remedial learning for slow learners and extended exercises for gifted learners.
  - **Structure of a lesson**  
All the lessons have these main features:
    - Lesson number and title
    - Pre-requisite of the lesson –

guidance on how to begin the lesson.

- Teaching aids or resources in line with the teaching objectives.
- Suggested learning activities
- *Lesson synthesis* – which is an indication to the teacher on how to go about in order to meet the lesson objective(s).

*Assesment* – A suggestion or how to assess whether lesson objectives have been met.

## 1.2 Background Information on new curriculum

The goal to develop a competence-based society, the globalisation process, and particularly the growth of the world market and competition at the global level, as well as a shift from knowledge-based to competence-based curriculum necessitated a comprehensive review of the national curriculum to address the required skills in the Rwandan education system.

It is against this background that the Chemistry syllabus at secondary level was reviewed to ensure that the syllabus is responsive to the needs of the learner with a shift from knowledge-based learning to competence-based learning.

Competence-based learning refers to systems of instruction, assessment, grading, and academic reporting that are based on students demonstrating that they have acquired and learned the prerequisite knowledge, skills and attitudes as they progress through their education. Apart

from being integrative, the newly revised syllabus guides the interaction between the teacher and the learner in the learning process. It further puts greater emphasis on skills a learner should acquire during each unit of learning. As a competence-based syllabus, it elaborates on the three aspects of knowledge, skills and attitudes and values in science.

## 1.3 Rationale of teaching and learning Chemistry

Teaching Chemistry to young people is critical for establishing a foundation for success in Industrialisation and for coping with the demands of the 21<sup>st</sup> century. Furthermore, chemistry not only important in developed countries but also in developing countries such as Rwanda. The love and interest in chemistry begins in primary school where young children tend to be more curious and motivated to learn science. Most importantly, this cultivates a positive attitude towards chemistry and provides learners with opportunities to experience the excitement of working as a chemist.

Above all, the rationale of teaching and learning Chemistry is embedded in the need for learners to have a greater awareness of the role of chemistry in everyday life. Chemistry at secondary school enables the learner to develop competencies, which have great impact in the society in general. Teaching Chemistry at secondary school is further justified in that it helps to develop cultural and democratic notions of scientific literacy.

Further, chemistry strives to equip learners to understand and situate scientific and technological developments in their cultural, environmental, economic, political and social contexts. At the centre of teaching and learning Chemistry, hands on activities will play a key role, which in turn, should contribute significantly towards improving learner's achievement, motivation and technological literacy.

## 1.4 Types of competences and their acquisition

Competencies are statements of the characteristics that students should demonstrate which indicate they are prepared and have the ability to perform independently in professional practice. The two types of competencies envisaged in this curriculum are basic and generic competences.

### (a) Basic competences

Basic competences are addressed in the stated broad subject competences and in objectives highlighted year on year basis and in each of units of learning. They include:

#### (i) Literacy

- Reading a variety of texts accurately and quickly.
- Expressing ideas, messages and events through writing legible texts in good hand-writing with correctly spelt words.
- Communicating ideas effectively through speaking using correct phonetics of words.

- Listening carefully for understanding and seeking clarification when necessary

#### (ii) Numeracy

- Computing accurately using the four mathematical operations.
- Manipulating numbers, mathematical symbols, quantities, shapes and figures to accomplish a task involving calculations, measurements and estimations.
- Use numerical patterns and relationships to solve problems related to everyday activities like commercial context and financial management.
- Interpreting basic statistical data using tables, diagrams, charts and graphs.

#### (iii) Citizenship and national identity

- Relating the impact of historical events on past and present national and cultural identity.
- Understanding the historical and cultural roots of Rwandan society and how the local infrastructure functions in relation to the global environment.
- Demonstrating respect for cultural identities and expressing the role of the national language in social and cultural context.
- Advocating for the historical, cultural and geographical heritage of the nation within the global dimension.
- Showing national consciousness, a

strong sense of belonging and patriotic spirit.

- Advocating for a harmonious and cohesive society and working with people from diverse cultural backgrounds.

#### **(iv) Entrepreneurship and business development**

- Applying entrepreneurial attitudes and approaches to challenges and opportunities in school and in life.
- Understanding the obligations of the different parties involved in employment.
- Planning and managing micro projects and small and medium enterprises.
- Creation of employment and keeping proper books of accounts.
- Risk-taking in business ventures and in other initiatives.
- Evaluating resources needed for a business.

#### **(v) Science and technology**

- Apply science and technology skills to solve practical problems encountered in everyday life including efficient and effective performance of a given task.
- Develop a sense of curiosity, inquisitiveness and research to explain theories, hypotheses and natural phenomena
- Reason deductively and inductively in a logical way.
- Use and experiment with a range of objects and tools of science and technology and draw appropriate conclusions.

### **(b) Generic competences**

The generic competencies are competences that must be emphasized and reflected in the learning process. They are briefly described below and teachers must ensure that learners are engaged in tasks that help them to acquire the competences.

#### **(i) Critical thinking and problem-solving skills**

The acquisition of such skills will help learners to think imaginatively, innovatively and broadly and be able to evaluate and find solutions to problems encountered in their surroundings.

#### **(ii) Creativity and innovation**

The acquisition of such these skills will help learners to take initiatives and use imagination beyond knowledge provided in classroom to generate new ideas and construct new concepts.

#### **(iii) Research skills**

This will help learners to find answers to questions based on existing information and concepts and use it to explain phenomena from gathered information.

#### **(iv) Communication in official languages**

Teachers, irrespective of being language teachers should ensure the proper use of the language of instruction by learners (which is English at Primary 4 level). The teachers should communicate clearly and confidently and convey ideas effectively through spoken and written English by applying appropriate grammar and relevant vocabulary.

### **(v) Cooperation, inter-personal management and life skills**

This will help the learner to cooperate in a team in whatever task assigned and to practice positive ethical moral values and while respecting rights, feelings and views of others. Perform practical activities related to environmental conservation and protection. Advocate for personal, family and community health, hygiene and nutrition and responding creatively to a variety of challenges encountered in life.

### **(vi) Lifelong learning skills**

The acquisition of such skills will help learners to update knowledge and skills with minimum external support. The learners will be able to cope with evolution of knowledge advances for personal fulfillment in areas that are relevant to their improvement and development.

## **Role of Chemistry as a subject in developing the competences**

The national policy documents based on national aspirations identify some basic Competencies alongside the Generic Competencies that will develop higher order critical thinking skills and help the students to learn chemistry. The nature of learning activities which are mainly inquiry-oriented contribute to the achievement of those competencies. Through observations, experimentation, and presentation of information during the learning process, the learner will not only develop deductive and inductive skills but also acquire cooperation and communication, critical thinking and

problem-solving skills. This will be realised when learners make presentations leading to inferences and conclusions at the end of learning unit. This will be achieved through learner group work and cooperative learning of Chemistry, which in turn will promote interpersonal relations and teamwork.

The manipulation of apparatus and data during class experiments and undertaking of project work by learners will involve analytical and problem-solving skills directed towards innovation, creativity and research activities by learners.

The acquired knowledge in learning Chemistry should develop a responsible citizen who adapts to scientific reasoning and attitudes and develops confidence in reasoning independently. The learner should show concern of individual attitudes, environmental protection and comply with the scientific method of reasoning. The scientific method should be applied with the necessary rigor, intellectual honesty to promote critical thinking while systematically pursuing the line of thought.

## **1.5 Cross-cutting issues to be addressed during learning**

These are emerging issues which need to be incorporated in the learning process. Each of the cross-cutting issues has its own important programme of learning reflecting key national priorities. This learning is integrated into the syllabuses of subjects across the curriculum rather than each issue having a dedicated timetable slot of its own. As a result of this integration, the learning

activities in the units of subjects across the curriculum incorporate all the learning associated with the cross-cutting issues. The eight cross-cutting issues are:

### **(a) Peace and Values Education**

The need for Peace and Values Education in the curriculum is obvious. Peace is clearly critical for society to flourish and for every individual to focus on personal achievement and their contribution to the success of the nation. Values education forms a key element of the strategy for ensuring young people recognize the importance of contributing to society, working for peace and harmony and being committed to avoiding conflict.

### **(b) Financial Education**

Financial education makes a strong contribution to the wider aims of education. It makes learning relevant to real life situations. It aims at a comprehensive financial education program as a precondition for achieving financial inclusion target and improves the financial capability of Rwandans. Financial education has a key role of not only improving knowledge of personal but also transforming this knowledge into action. It provides the tools for sound money management practices on earnings, spending, saving, borrowing and investing. Financial education enables people to take appropriate financial services both formal and informal that are available to them and encourages financial behaviours that enhance their overall economic well-being.

### **(c) Standardisation culture**

Standardisation Culture develops learners' understanding of the importance of standards as a pillar of economic development and in the practices, activities and lifestyle of the citizens. It is intended that the adoption of standardization culture should have an impact upon health improvement, economic growth, industrialization, trade and general welfare of the people. While education is the foundation and strength of our nation, standards are one of the key pillars of sustainable economic development.

### **(d) Genocide studies**

Genocide Studies provides young people with an understanding of the circumstances leading to the genocide and the remarkable story of recovery and re-establishing national unity. Genocide Studies helps learners to comprehend the role of every individual in ensuring nothing of the sort ever happens again.

The intent of a cross-cutting curriculum around the topic of genocide is to fight against genocide, genocide denial, and genocide ideology; and to equip students with a more fundamental and comprehensive understanding of the genocide, thereby preventing further human rights violations in the future and enabling Rwanda's population of young people to more competently and thoughtfully enter the workforce. So, it needs to be emphasized.

### **(e) Environment and sustainability**

The growing awareness of the impact of the human race on the environment has led to recognition of the need to ensure our young people understand the importance of sustainability as they grow up and become responsible for the world around them. Hence Environment and Sustainability is a very important cross-cutting issue. Learners need basic knowledge from the natural sciences, social sciences and humanities to understand and interpret principles of sustainability. They also need skills and attitudes that will enable them in their everyday life to address the environment and climate change issue and to have a sustainable livelihood.

### **(f) Gender education**

There is a strong moral imperative to afford every individual their basic human rights and gender inequality results in women and girls being treated less favourably than men. A strongly negative impact of unequal treatment, which affects the nation as a whole, is the fact that it results in women being held back and their talents and abilities not being fully realised. With a good understanding of the principles of Gender Equality, it is intended that future generations will ensure that the potential of the whole population is realised.

### **(g) Comprehensive sexuality education (HIV and AIDS, STIs, Family planning and reproductive health)**

Comprehensive sexuality education, which is age-appropriate scientifically accurate, culturally relevant, gender-sensitive and life skills-based can provide young people with the knowledge and skills to make informed decisions about their sexuality and life-style. Preparing students and young people in general for the transition to adulthood has been one of humanity's greatest challenges with human sexuality and relationships at its core. Few young people receive adequate preparations for their sexual lives. This leaves them potentially vulnerable to coercion, abuse and exploitation. Unintended pregnancy and sexually transmitted infections (STIs) including HIV and AIDS. Many young people approach adulthood faced with conflicting and confusing messages about sexuality and gender. This is often exacerbated by embarrassment, silence, disapproval and open discussion of sexual matters by adults (parents, teachers) at very time when it is most needed.

Comprehensive sexuality education supports a rights - based approach in which values such as respect, acceptance tolerance, equality, empathy and reciprocity are inextricably linked to universally agreed human rights. A clear message concerning these dangers and how they can be avoided, from right across the curriculum is the best way to ensure that young people understand the risks and know how to stay healthy.



## **(h) Inclusive Education**

Inclusive education involves ensuring all learners are engaged in education and that they are welcomed by other students so that everyone can achieve their potential. Inclusive practice embraces every individual regardless of gender or ability including those with learning difficulties and disabilities. The almost focus of inclusive curriculum is on ensuring participation in education of learners with different learning styles and other difficulties. To be successful, it entails a range of issues including teacher's positive attitudes, adapting the learning resources, differentiation of teaching and learning methods and working together. Overall, the benefits of an inclusive curriculum extend to all learners.

### **1.6 Special needs education and inclusivity**

All Rwandans have the right to access education regardless of their different needs. The underpinnings of this provision would naturally hold that all citizens benefit from the same menu of educational programs. The possibility of this assumption is the focus of special needs education. The critical issue is that we have persons/ learners who are totally different in their ways of living and learning as opposed to the majority. The difference can either be emotional, physical, sensory and intellectual learning challenges traditionally known as mental retardation. These learners equally have the right to benefit from the free and compulsory basic education in the nearby ordinary/ mainstream schools. Therefore, the schools'

role is to enrol them and also set strategies to provide relevant education to them. The teacher therefore is requested to consider each learner's needs during teaching and learning process. Assessment strategies and conditions should also be standardised to the needs of these learners. Also, ensure that you include learners with special educational needs in classroom activities as much as possible.

The special needs learners can fall in any of the following common categories:

- Physical difficulties
- Visual difficulties
- Hearing difficulties
- Intellectual difficulties
- Emotional disorders

The teacher should identify such cases and help facilitate the affected learners during learning. For example, learner's with visual and hearing difficulties should sit near the teacher's table for easy supervision and assistance. The following are some suggestions on how to support special needs children in your class.

#### **(a) Learners with physical difficulties**

In this group of learners, the affected areas are normally some body parts, especially the limbs. There may be partial or total loss of use of the limbs. In case the legs are affected, the learners will need assistance during activities that involve movement. This could be during a nature walk and other activities that learners have to stand for some reason. The teacher should organize for the learner's ease of movement around.



The learner should also be given time to catch up with the others.

In case the hands are affected, the learners should be given more time to finish their work. In both cases, the learners should not be pressurized to do things that can cause injury or ridicule.

### **(b) Learners with visual difficulties**

These learners normally have problems with their eyesight. They should sit in a position where they are able to see the chalkboard without straining. Such learners could be long-sighted or short-sighted.

The material to be observed should be brought closer to the learner and a magnifying lens used where necessary. The teacher should use large diagrams, charts and labels. In some cases, the learners can be allowed to touch and feel whatever they are looking at. Other learners can assist by reading aloud. The lighting system in the classroom can also be improved.

The teacher should read aloud most of the things he/she writes on the chalkboard.

### **(c) Learners with hearing difficulties**

The affected part in this case is the ear. The learner should have hearing aids. The teacher should use as many visual aids as possible. They should also project their voice and always talk while facing the learners. Use of gestures and signs while talking helps the learner figure out what the teacher is saying as well.

### **(d) Learners with speech difficulties**

A common example in a normal class is the **stammerer**. They always speak with a lot of difficulties. The teacher should be patient with them and encourage such learners to express themselves in their own way. Such learners should be given more written exercises.

### **(e) Learners with intellectual difficulties**

The teacher should try to identify the nature and level of the intellectual difficulty. Learners with intellectual difficulties should then be given special assistance and attention at an individual level. They can be given special tests or assessments. In general, all the learners with difficulties should be reinforced promptly. This encourages and motivates them. The teacher and the rest of the class should never ridicule learners with any of such difficulties. Note that generally, people with any kind of disability can be very sensitive to any kind of negative comments or criticism. Remind them that 'Disability is not inability'.

The teacher should avoid giving privileges where the learners do not deserve them. Treat them fairly but not with undue favours.

## (F) Learners with emotional disorders

These are learners who get annoyed easily either because of past life experiences or it may just be their nature. The teacher should handle this category of learners with care and caution other learners against mishandling them.

### 1.7 Classroom organisation

A well organised classroom is an asset to good teaching of Chemistry but there is no one correct style to suit all classrooms and situations. However, the teacher should consider the following factors when organising the classroom:

- Furniture should be well arranged so as to allow free movement of learners and the teacher.
- Set a corner for storing materials so as not to obstruct learners or distract them.
- The number of learners in the class and their ages.
- Learners should be reasonably spread out so that they do not interfere with one another's activities.
- The series of lessons or activities going on for a number of days or weeks such as individual or group work or whole class.

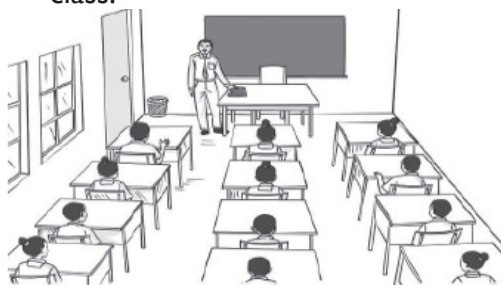

Fig. 1.1 Sample classroom arrangement

- Classroom itself, that is, positions of windows, doors such that learners face the lighted areas of the room.
- Personal preferences. But these should be in the interest of the learners especially where the teacher normally stands, the teacher should be able to communicate with all learners and also have a general view of all learners in the class.

In certain lessons, the teacher may wish to carry out a demonstration. In this case, the learners should be sitting or standing in a semicircle, or arranged around an empty shape of letter “U” such that each learner can see what the teacher is doing clearly and without obstruction or pushing.

### Grouping learners for learning

Most of the science activities are carried out in groups and therefore the teacher should place 2 or 3 desks against each other and then have a group of learners sitting around those desks.

If the learners are involved in individual work, each learner can work on the floor or on the desk or a portion of the desk if they are sharing. In this case, they need not face each other.

Grouping learners for learning has increasingly become popular in recent years. In fact, the shift from knowledge-based to competence-based curriculum will make

grouping the norm in the teaching process. Grouping learners can be informed by one or all of the following:

- (a) Similar ability grouping.
- (b) Mixed ability grouping.
- (c) Similar interests grouping.
- (d) Needs grouping.
- (e) Friendship grouping.
- (f) Sex grouping.

In Science, groupings are commonly those of types (a), (b), (c) and (d). Grouping learners has several advantages such as:

- (a) The individual learner's progress and needs can easily be observed.
  - (b) The teacher-learner relationship is enhanced.
  - (c) A teacher can easily attend to the needs and problems of a small group.
  - (d) Materials that were inadequate for individual work can now easily be shared.
  - (e) Learners can learn from one another.
  - (f) Cooperation among learners can easily be developed.
  - (g) Many learners accept correction from the teacher more readily and without feeling humiliated when they are in a small group rather than the whole class.
  - (h) Learners' creativity, responsibility and leadership skills can easily be developed.
  - (i) Learners can work at their own pace.
- The type of "grouping" that a teacher may choose depends on:
- (a) The topic or task to be tackled.

- (b) The materials available.
- (c) Ability of learners in the class.

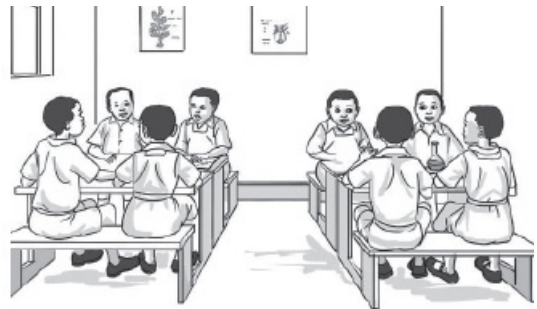

*Fig. 1.2 Sample classroom grouping*

However, the teacher must be flexible enough to adjust or change his/her type of grouping to cope with new situations.

There is no fixed number of learners that a group must have. This again will be dictated by such factors as the task to be done, the material available, characteristics of learners in your class, size and the space available. However, groups should on average have between **four to seven learners**. You can also resort to pairwork depending on the nature of the content being taught at the time.

**Note:**

There is no one method or approach to teaching that is appropriate to all lessons. A teacher should, therefore, choose wisely the method to use or a combination of methods depending on the nature of the topic or subtopic at hand.

### **1.8 Safety in the classroom**

Students in primary school are extremely active and curious. As such, they are inclined to getting harmed and injured. They should therefore be constantly protected from

sources of injury and harm. The teacher is therefore advised to take strict safety precautions whenever learners are in class or outside the classroom. Some areas that need consideration as far as safety is concerned include:

- During tasting and smelling things.
- When using tools and equipment.
- During experiments, demonstrations involving use of fire or harmful chemicals.
- When handling glass apparatus.
- When handling sharp or pointed objects like machete, pair of scissors, razor-blade, knife, etc.
- During nature walks and field visits. Learners should avoid handling poisonous plants and harmful animals, etc.

Remember, according to Rwanda laws, the teacher is responsible for the safety of the learners during the period he or she is handling them.

## 1.9 Assessment and evaluation methods

Assessment is the process of evaluating the teaching and learning processes through collecting and interpreting evidence of individual learner's progress in learning and to make a judgment about a learner's achievements measured against defined standards. Assessment is an integral part of the teaching and learning processes. In the new competence-based curriculum assessment must also be competence-based; whereby a learner is given a complex situation related to his/her everyday life and asked to try to overcome the situation by applying what he/she learned.

## Types of assessment

The two types of assessment that will be employed in the new curriculum is **formative** and **summative** assessment.

### (a) Formative or continuous assessment (assessment for learning)

Formative or continuous assessment involves formal and informal methods used by schools to check whether learning is taking place. When the teacher is planning his/her lesson, he/she should establish criteria for performance and behaviour changes at the beginning of the unit. Then at the end of every unit, the teacher should ensure that all the learners have mastered the stated key unit competencies basing on the criteria stated, before going to the next unit. The teacher will assess how well each learner masters both the subject matter and the generic competencies described in the syllabus and from this, the teacher will gain a picture of the all-round progress of the learner. The teacher will use one or a combination of the following:

- Observations - to judge the extend of skills acquisition
- Written tests
- Practical work/activities
- Oral questions or interviews
- Project works
- Attitude change – this can be done by asking probing questions and checking body language as learners respond to the questions.

### (i) Written tests

Under this, learners are given questions or tasks and are required to respond in writing. Examples of written tests are: short answer type questions, structured type questions, filling blanks, multiple choice questions, true-false questions and matching items.

### (ii) Practical work activity

In this category, learners are required to perform a task or solve a problem practically. The teacher then assesses the finished work by looking at the materials used, procedures followed, whether it works or not or whether it is finished. He or she then awards marks accordingly.

### (iii) Observation

This involves the teacher observing learners as they perform a practical task to assess acquisition of skills and attitude change. The teacher checks ability of the learner to measure, classify, communicate findings, etc. He or she also assesses the learner's

curiosity, patience, team and co-operation spirit among others.

### (iv) Oral questions or interviews

Asking learners questions which require a verbal response such as naming parts of human body, a system or short explanations of a process such as digestion can also be used to assess learner's level of competence.

### (iv) Project work

In a project, learners undertake a comprehensive study of something in real life over a period of time such as several weeks or even months after which they present a report. In project work, let learners begin from planning stage (come up with a schedule of events), execute the plan, analyse the results and look back (reflect on the challenges encountered during the project and come up with solutions to those challenges (problem-solving skills).

A teacher can use one or several of these assessment methods depending on the subtopic being studied or the purpose for which assessment is done.

Criteria used to gauge learner achievement in the various generic competence areas is given in the table below.

Name of Learner	COMM	I&C	CT	RS	LL	PS	C&I
A	Red	Blue	Yellow	Blue	Red	Green	Yellow
B	Yellow	Red	Blue	Yellow	Blue	Red	Blue
C	Green	Blue	Red	Yellow	Blue	Red	Yellow
D	Yellow	Green	Yellow	Red	Yellow	Yellow	Green
E	Red	Blue	Yellow	Blue	Yellow	Red	Blue
F	Blue	Yellow	Red	Yellow	Blue	Green	Red
G	Yellow	Green	Blue	Yellow	Red	Blue	Green

KEY: Red – Poor

Green – Good

Yellow – Excellent

Blue – Average

RS – Research Skills

PS – Problems-solving skills

COMM – Communication in English

I & C – Interpersonal skills & Co-operation

CT – Critical Thinking

LL – Life long skills

C & I – Creativity & Innovation

Allocate marks for each colour and calculate the marks that the learner has attained. Grade the learners based on how they have scored here and in the various tests given to assess skills acquisition and attitude change.

### **(b) Summative assessment (assessment of learning)**

When assessment is used to record a judgment of a competence or performance of the learner, it serves a summative purpose. Summative assessment gives a picture of a learner's competence or progress at any specific moment. The main purpose of summative assessment is to evaluate whether learning objectives have been achieved and to use the results for the ranking or grading of learners, for deciding on progression, for selection into the next level of education and for certification. This assessment should have an integrative aspect whereby a student must be able to show mastery of all competencies.

It can be internal school-based assessment or external assessment in the form of national examinations.

### **Item writing in summative assessment**

Before developing a question paper, a plan or specification of what is to be tested or examined must be elaborated to show

the units or topics to be tested on, the number of questions in each level of Bloom's taxonomy and the marks allocation for each question. In a competency-based curriculum, questions from higher levels of Bloom's taxonomy should be given more weight than those from knowledge and comprehension level.

Before developing a question paper, the item writer must ensure that the test or examination questions are tailored towards competence based assessment by doing the following:

- Identify topic areas to be tested on from the subject syllabus.
- Outline subject matter content to be considered as the basis for the test.
- Identify learning outcomes to be measured by the test.
- Prepare a table of specifications.
- Ensure that the verbs used in the formulation of questions do not require memorisation or recall answers only but testing broad competencies as stated in the syllabus.

### **Record Keeping**

This is gathering facts and evidence from assessment instruments and using them to judge the student's performance by

assigning an indicator against the set criteria or standard. Whatever assessment procedures used shall generate data in the form of scores which will be carefully be recorded and stored in a portfolio because they will contribute for remedial actions, for alternative instructional strategy and feed back to the learner and to the parents to check the learning progress and to advice accordingly or to the final assessment of the students.

This portfolio is a folder (or binder or even a digital collection) containing the student's work as well as the student's evaluation of the strengths and weaknesses of the work. Portfolios reflect not only work produced (such as papers and assignments), but also it is a record of the activities undertaken over time as part of student learning. The portfolio output (formative assessment)

will be considered only as enough for three years of Advanced level. Besides, it will serve as a verification tool for each learner that he/she attended the whole learning before he/she undergoes the summative assessment for the subject. The results from the portfolio will contribute 50% on summative assessment of each year.

## **Reporting to parents**

The wider range of learning in the new curriculum means that it is necessary to think again about how to share learners' progress with parents. A single mark is not sufficient to convey the different expectations of learning, which are in the learning objectives. The most helpful reporting is to share what students are doing well and where they need to improve.



## SECTION

## 2

## CONTENT MAP

	Unit 1	Unit 2	Unit 3	Unit 4
<b>Number of periods</b>	15	15	15	15
<b>Key Unit Competence</b>	By the end of this unit, the learner should be able to relate the properties of carbon and its compounds to its uses. Describe how some of its compounds are prepared.	By the end of this unit, the learner should be able to relate the properties of nitrogen and its compounds to their uses. Describe how some of compounds of nitrogen are prepared and discuss the related environmental issues	By the end of this unit, the learner should be able to relate the properties of sulphur and its compounds to their uses. Describe how its compounds are prepared and discuss related environmental issues	By the end of this unit, the learner should be able to relate the properties of chlorine and its compounds to its uses. Describe how its compounds are prepared and discuss related environmental issues.
<b>Number of Lessons</b>	7	7	6	6



	<b>Unit 1</b> <b>Carbon and its inorganic compounds</b>	<b>Unit 2</b> <b>Nitrogen and its inorganic compounds</b>	<b>Unit 3</b> <b>Sulphur and its inorganic compounds.</b>	<b>Unit 4</b> <b>Chlorine and its inorganic compounds</b>
<b>Equipment / Learning / Teaching materials required</b>	<input type="checkbox"/> Charts on carbon and its inorganic compounds <input type="checkbox"/> Internet links <input type="checkbox"/> Chalkboard diagrams <input type="checkbox"/> Dictionary <input type="checkbox"/> Laboratory apparatus and reagents as given in the individual lesson under teaching aids/resources. <input type="checkbox"/> Reference materials in your possession <input type="checkbox"/> Learners text book	<input type="checkbox"/> Laboratory apparatus and reagents <input type="checkbox"/> Reference materials in your possession <input type="checkbox"/> Learners text book <input type="checkbox"/> Charts on nitrogen compounds <input type="checkbox"/> Internet links <input type="checkbox"/> Chalkboard diagrams	<input type="checkbox"/> Text books <input type="checkbox"/> Charts on sulphur <input type="checkbox"/> Internet links <input type="checkbox"/> Chalkboard diagrams <input type="checkbox"/> Laboratory apparatus and reagents <input type="checkbox"/> Reference material in your possession <input type="checkbox"/> Learners text book	<input type="checkbox"/> Chalkboard diagrams <input type="checkbox"/> Dictionary <input type="checkbox"/> Laboratory apparatus and reagents <input type="checkbox"/> Text books <input type="checkbox"/> Charts on chlorine <input type="checkbox"/> Internet links <input type="checkbox"/> Reference materials in your possession <input type="checkbox"/> Learners text book
<b>Activities / Techniques</b>	<input type="checkbox"/> Case studies <input type="checkbox"/> Role-plays <input type="checkbox"/> Practical activities <input type="checkbox"/> Research activities <input type="checkbox"/> Group work <input type="checkbox"/> Question and answers <input type="checkbox"/> Discussion and presentation <input type="checkbox"/> Experimentation	<input type="checkbox"/> Discussion and presentation <input type="checkbox"/> Experimentation <input type="checkbox"/> Field trips <input type="checkbox"/> Case studies <input type="checkbox"/> Practical activities <input type="checkbox"/> Research activities <input type="checkbox"/> Group work <input type="checkbox"/> Question and answers	<input type="checkbox"/> Research activities <input type="checkbox"/> Field trips <input type="checkbox"/> Case studies <input type="checkbox"/> Practical activities <input type="checkbox"/> Group work <input type="checkbox"/> Question and answers <input type="checkbox"/> Discussion and presentation <input type="checkbox"/> Experimentation	<input type="checkbox"/> Field trips <input type="checkbox"/> Role-plays <input type="checkbox"/> Practical activities <input type="checkbox"/> Research activities <input type="checkbox"/> Group work <input type="checkbox"/> Question and answers <input type="checkbox"/> Discussion and presentation <input type="checkbox"/> Experimentation

	<p><b>Unit 1</b> Carbon and its inorganic compounds</p>	<p><b>Unit 2</b> Nitrogen and its inorganic compounds</p>	<p><b>Unit 3</b> Sulphur and its inorganic compounds.</p>	<p><b>Unit 4</b> Chlorine and its inorganic compounds</p>
<p><b>Generic Competences Practiced</b></p>	<ul style="list-style-type: none"> <li>• Research skills</li> <li>• Communication in English</li> <li>• Cooperation and Interpersonal skills</li> <li>• Critical thinking and problem solving skills</li> </ul>	<ul style="list-style-type: none"> <li>• Cooperation and interpersonal skills</li> <li>• Critical thinking and problem solving skills</li> <li>• Research skills</li> <li>• Communication in English</li> <li>• Cooperation and interpersonal skills</li> </ul>	<ul style="list-style-type: none"> <li>• Critical thinking and problem solving skills</li> <li>• Research skills</li> <li>• Communication in English</li> <li>• Cooperation and interpersonal skills</li> </ul>	<ul style="list-style-type: none"> <li>• Research skills</li> <li>• Communication in English</li> <li>• Cooperation and interpersonal skills</li> <li>• Critical thinking and problem solving skills</li> </ul>

	<b>Unit 1</b> <b>Carbon and its inorganic compounds</b>	<b>Unit 2</b> <b>Nitrogen and its inorganic compounds</b>	<b>Unit 3</b> <b>Sulphur and its inorganic compounds.</b>	<b>Unit 4</b> <b>Chlorine and its inorganic compounds</b>
<b>Cross-cutting issues addressed</b>	<ul style="list-style-type: none"> <li>• Environment and sustainability education</li> <li>• Peace and values education:</li> <li>• Health education</li> <li>• Inclusive learning</li> <li>• Gender education</li> <li>• Financial education</li> <li>• Standardisation culture</li> </ul>	<ul style="list-style-type: none"> <li>• Inclusive learning</li> <li>• Gender education</li> <li>• Financial education</li> <li>• Standardisation culture</li> <li>• Environment and sustainability education:</li> <li>• Peace and values education</li> <li>• Health education</li> </ul>	<ul style="list-style-type: none"> <li>• Peace and values education:</li> <li>• Health education</li> <li>• Inclusive learning</li> <li>• Gender education</li> <li>• Financial education</li> <li>• Standardisation culture</li> <li>• Environment and sustainability education</li> </ul>	<ul style="list-style-type: none"> <li>• Gender education</li> <li>• Financial education</li> <li>• Standardisation culture</li> <li>• Environment and sustainability education</li> <li>• Peace and values education</li> <li>• Health education</li> <li>• Inclusive learning</li> </ul>

	<p><b>Unit 1</b></p> <p><b>Carbon and its inorganic compounds</b></p>	<p><b>Unit 2</b></p> <p><b>Nitrogen and its inorganic compounds</b></p>	<p><b>Unit 3</b></p> <p><b>Sulphur and its inorganic compounds.</b></p>	<p><b>Unit 4</b></p> <p><b>Chlorine and its inorganic compounds</b></p>
<p><b>Assessment Strategies of Key unit Competence</b></p>	<ul style="list-style-type: none"> <li><input type="checkbox"/> Guidance on the problem statement at the beginning of the unit.</li> <li><input type="checkbox"/> Activities 1.1 – 1. 18</li> <li><input type="checkbox"/> Self –evaluation test at the end of each lesson</li> <li><input type="checkbox"/> Test your Competence 1 at the end of the unit</li> </ul>	<ul style="list-style-type: none"> <li><input type="checkbox"/> Guidance on the problem statement at the beginning of the unit</li> <li><input type="checkbox"/> Activities 2.1 – 2.17</li> <li><input type="checkbox"/> Self –evaluation test at the end of each lesson</li> <li><input type="checkbox"/> Test your Competence 2 at the end of the unit</li> </ul>	<ul style="list-style-type: none"> <li><input type="checkbox"/> Guidance on the problem statement at the beginning of the unit</li> <li><input type="checkbox"/> Activities 3.1 – 3.7</li> <li><input type="checkbox"/> Self –evaluation test at the end of each lesson</li> <li><input type="checkbox"/> Test your Competence 3 at the end of the unit</li> </ul>	<ul style="list-style-type: none"> <li><input type="checkbox"/> Guidance on the problem statement at the beginning of the unit</li> <li><input type="checkbox"/> Activities 4.1 – 4.13</li> <li><input type="checkbox"/> Self –evaluation test at the end of each lesson</li> <li><input type="checkbox"/> Test your Competence 4 at the end of the unit</li> </ul>

	<b>Unit 5</b> <b>Rate of reactions</b>	<b>Unit 6</b> <b>Chemical properties of acids and bases</b>	<b>Unit 7</b> <b>Concentration of solutions</b>	<b>Unit 8</b> <b>Electrolysis and its applications</b>
<b>Number of periods</b>	12	8	15	18
<b>Key Unit Competence</b>	By the end of this unit, the learner should be able to describe and explain the effect of different conditions on the speed of reactions.	By the end of this unit, the learner should be able to prepare and carry out reactions of acids and bases with other substances	By the end of this unit, the learner should be able to determine the concentrations of solutions from data obtained by simple acid-base titration.	By the end of this unit, the learner should be able to examine and explain the electrolysis of different electrolytes and state their application in daily life.
<b>Number of Lessons</b>	6	3	3	3
<b>Equipment / Learning / Teaching materials required</b>	<input type="checkbox"/> Laboratory apparatus and reagents <input type="checkbox"/> Charts on rates of reaction <input type="checkbox"/> Internet links <input type="checkbox"/> Chalkboard diagrams <input type="checkbox"/> Reference materials in your possession <input type="checkbox"/> Learners text book	<input type="checkbox"/> Internet links <input type="checkbox"/> C h a l k b o a r d diagrams <input type="checkbox"/> Reference books <input type="checkbox"/> Learners text book <input type="checkbox"/> Samples of acids and bases <input type="checkbox"/> Charts on acids and bases <input type="checkbox"/> L a b o r a t o r y apparatus and reagents	<input type="checkbox"/> Charts on concentration <input type="checkbox"/> Internet links <input type="checkbox"/> Chalkboard diagrams <input type="checkbox"/> Laboratory apparatus and reagents <input type="checkbox"/> Reference materials in your possession <input type="checkbox"/> Learners text book <input type="checkbox"/> Samples	<input type="checkbox"/> Reference materials in your possession <input type="checkbox"/> Learners text book <input type="checkbox"/> Samples <input type="checkbox"/> Charts on electrolysis <input type="checkbox"/> Internet links <input type="checkbox"/> Chalkboard diagrams <input type="checkbox"/> Laboratory apparatus and reagents

	<b>Unit 5</b> <b>Rate of reactions</b>	<b>Unit 6</b> <b>Chemical properties of acids and bases</b>	<b>Unit 7</b> <b>Concentration of solutions</b>	<b>Unit 8</b> <b>Electrolysis and its applications</b>
<b>Activities / Techniques</b>	<input type="checkbox"/> Case studies <input type="checkbox"/> Role-plays <input type="checkbox"/> Practical activities <input type="checkbox"/> Research activities <input type="checkbox"/> Group work <input type="checkbox"/> Question and answers <input type="checkbox"/> Discussion and presentation <input type="checkbox"/> Experimentation	<input type="checkbox"/> Field trips <input type="checkbox"/> Role-plays <input type="checkbox"/> Practical activities <input type="checkbox"/> Research activities <input type="checkbox"/> Group work <input type="checkbox"/> Question and answers <input type="checkbox"/> Discussion and presentation <input type="checkbox"/> Experimentation	<input type="checkbox"/> Research activities <input type="checkbox"/> Case studies <input type="checkbox"/> Role-plays <input type="checkbox"/> Practical activities <input type="checkbox"/> Group work <input type="checkbox"/> Question and answers <input type="checkbox"/> Discussion and presentation <input type="checkbox"/> Experimentation	<input type="checkbox"/> Discussion and presentation <input type="checkbox"/> Experimentation case studies <input type="checkbox"/> Practical activities <input type="checkbox"/> Research activities <input type="checkbox"/> Group work <input type="checkbox"/> Question and answers
<b>Generic Competences Practiced</b>	<ul style="list-style-type: none"> <li>• Research skills</li> <li>• Communication in English</li> <li>• Cooperation and interpersonal skills</li> <li>• Critical thinking and problem solving skills</li> <li>• Lifelong learning skills</li> </ul>	<ul style="list-style-type: none"> <li>• Critical thinking and problem solving skills</li> <li>• Communication in English</li> <li>• Cooperation and interpersonal skills</li> <li>• Lifelong learning skills</li> <li>• Research skills</li> </ul>	<ul style="list-style-type: none"> <li>• Research skills</li> <li>• Lifelong skills</li> <li>• Critical thinking and problem solving skills</li> <li>• Communication in English</li> <li>• Cooperation and interpersonal skills</li> </ul>	<ul style="list-style-type: none"> <li>• Cooperation and interpersonal skills</li> <li>• Critical thinking and problem solving skills</li> <li>• Lifelong learning skills</li> <li>• Research skills</li> <li>• Communication in English</li> </ul>

	<b>Unit 5</b> <b>Rate of reactions</b>	<b>Unit 6</b> <b>Chemical properties of acids and bases</b>	<b>Unit 7</b> <b>Concentration of solutions</b>	<b>Unit 8</b> <b>Electrolysis and its applications</b>
<b>Cross-cutting issues addressed</b>	<ul style="list-style-type: none"> <li>• Inclusive learning</li> <li>• Gender education</li> <li>• Financial education</li> <li>• Standardisation culture</li> <li>• Environment and sustainability education</li> <li>• Peace and values education</li> <li>• Health education</li> </ul>	<ul style="list-style-type: none"> <li>• Peace and values education</li> <li>• Health education</li> <li>• Inclusive learning</li> <li>• Gender education</li> <li>• Financial education</li> <li>• Standardisation culture</li> <li>• Environment and sustainability education</li> </ul>	<ul style="list-style-type: none"> <li>• Financial education</li> <li>• Standardisation culture</li> <li>• Inclusive learning</li> <li>• Gender education</li> <li>• Environment and sustainability education</li> <li>• Peace and values education</li> <li>• Health education</li> </ul>	<ul style="list-style-type: none"> <li>• Standardisation culture</li> <li>• Environment and sustainability education</li> <li>• Peace and values education</li> <li>• Inclusive learning</li> <li>• Gender education</li> <li>• Financial education</li> <li>• Health education</li> </ul>
<b>Assessment Strategies of Key Unit competence</b>	<p>Guidance on the problem statement at the beginning of the unit</p> <p>Activities 5.1 – 5.6</p> <p>Self –evaluation test at the end of each lesson</p> <p>Test your Competence 5 at the end of the unit</p>	<p>Guidance on the problem statement at the beginning of the unit</p> <p>Activities 6.1 – 6.6</p> <p>Self –evaluation test at the end of each lesson</p> <p>Test your Competence 6 at the end of the unit</p>	<p>Guidance on the problem statement at the beginning of the unit</p> <p>Activities 7.1 – 7.3</p> <p>Self –evaluation test at the end of each lesson</p> <p>Test your Competence 7 at the end of the unit</p>	<p>Guidance on the problem statement at the beginning of the unit</p> <p>Activities 8.1 – 8.7</p> <p>Self –evaluation test at the end of each lesson</p> <p>Test your Competence 8 at the end of the unit</p>

	<b>Unit 9</b> <b>Structure and properties of alkenes and alcohols</b>	<b>Unit 10</b> <b>Carboxylic acids</b>	<b>Unit 11</b> <b>Petroleum products and polymerisation</b>
<b>Number of periods</b>	15	6	10
<b>Key Unit Competence</b>	By the end of this unit, the learner should be able to relate the properties of alkenes and alcohols to their functional groups.	By the end of this unit, the learner should be able to explain the properties of carboxylic acids.	By the end of this unit, the learner should be able to explain the origin of petroleum products and application of polymers.
<b>Number of Lessons</b>	5	3	3
<b>Equipment / Learning / Teaching materials required</b>	<input type="checkbox"/> Charts on alkenes and alcohols <input type="checkbox"/> Internet links <input type="checkbox"/> Chalkboard diagrams <input type="checkbox"/> Laboratory apparatus and reagents <input type="checkbox"/> Reference materials in your possession <input type="checkbox"/> Learners text book	<input type="checkbox"/> Learner's text book <input type="checkbox"/> Samples <input type="checkbox"/> Charts on carboxylic acids <input type="checkbox"/> Internet links <input type="checkbox"/> Chalkboard diagrams <input type="checkbox"/> Dictionary <input type="checkbox"/> Laboratory apparatus and reagents <input type="checkbox"/> Reference materials in your possession	<input type="checkbox"/> Laboratory apparatus and reagents <input type="checkbox"/> Reference materials in your possession <input type="checkbox"/> Learners text book <input type="checkbox"/> Samples <input type="checkbox"/> Charts on petroleum products <input type="checkbox"/> Internet links <input type="checkbox"/> Chalkboard diagrams <input type="checkbox"/> Dictionary



	Unit 9 Structure and properties of alkenes and alcohols	Unit 10 Carboxylic acids	Unit 11 Petroleum products and polymerisation
<b>Activities / Techniques</b>	<input type="checkbox"/> Field trips <input type="checkbox"/> Case studies <input type="checkbox"/> Role-plays <input type="checkbox"/> Practical activities <input type="checkbox"/> Research activities <input type="checkbox"/> Group work <input type="checkbox"/> Question and answers <input type="checkbox"/> Discussion and presentation <input type="checkbox"/> Experimentation	<input type="checkbox"/> Group work <input type="checkbox"/> Question and answers <input type="checkbox"/> Discussion and presentation <input type="checkbox"/> Field trips <input type="checkbox"/> Case studies <input type="checkbox"/> Games <input type="checkbox"/> Practical activities <input type="checkbox"/> Research activities <input type="checkbox"/> Experimentation	<input type="checkbox"/> Research activities <input type="checkbox"/> Group work <input type="checkbox"/> Question and answers <input type="checkbox"/> Discussion and presentation <input type="checkbox"/> Field trips <input type="checkbox"/> Case studies <input type="checkbox"/> Games <input type="checkbox"/> Practical activities <input type="checkbox"/> Experimentation
<b>Generic Competences Practiced</b>	<ul style="list-style-type: none"> <li>• Cooperation and interpersonal management</li> <li>• Critical thinking and problem solving skills: Answer the probing questions and discuss the results</li> <li>• Lifelong learning skills</li> <li>• Research skills</li> <li>• Communication in English</li> </ul>	<ul style="list-style-type: none"> <li>• Critical thinking and problem solving skills</li> <li>• Answer the probing questions and discuss the results</li> <li>• Lifelong learning skills</li> <li>• Research skills</li> <li>• Communication in English</li> <li>• Cooperation and interpersonal management</li> </ul>	<ul style="list-style-type: none"> <li>• Lifelong learning skills</li> <li>• Research skills</li> <li>• Communication in English</li> <li>• Cooperation and interpersonal management</li> <li>• Critical thinking and problem solving skills</li> </ul>

<p><b>Cross-cutting issues addressed</b></p>	<ul style="list-style-type: none"> <li>• Financial education</li> <li>• Standardisation culture</li> <li>• Environment and sustainability education</li> <li>• Inclusive learning</li> <li>• Gender education</li> <li>• Peace and values education</li> <li>• Health education</li> </ul>	<ul style="list-style-type: none"> <li>• Standardisation culture</li> <li>• Environment and sustainability education</li> <li>• Gender education</li> <li>• Financial education</li> <li>• Peace and values education</li> <li>• Health education</li> </ul>	<ul style="list-style-type: none"> <li>• Peace and values education</li> <li>• Health education</li> <li>• Inclusive learning</li> <li>• Gender education</li> <li>• Financial education</li> <li>• Standardisation culture</li> <li>• Environment and sustainability education</li> </ul>
<p><b>Assessment Strategies of Key Unit competence</b></p>	<ul style="list-style-type: none"> <li><input type="checkbox"/> Guidance on the problem statement at the beginning of the unit</li> <li><input type="checkbox"/> Activities 9.1 – 9.8</li> <li><input type="checkbox"/> Self –evaluation test at the end of each lesson</li> <li><input type="checkbox"/> Test your Competence 9 at the end of the unit</li> </ul>	<ul style="list-style-type: none"> <li><input type="checkbox"/> Guidance on the problem statement at the beginning of the unit</li> <li><input type="checkbox"/> Activities 10.1 – 10.3</li> <li><input type="checkbox"/> Self –evaluation test at the end of each lesson</li> <li><input type="checkbox"/> Test your Competence 10 at the end of the unit</li> </ul>	<ul style="list-style-type: none"> <li><input type="checkbox"/> Guidance on the problem statement at the beginning of the unit</li> <li><input type="checkbox"/> Activities 11.1 – 11.4</li> <li><input type="checkbox"/> Self –evaluation test at the end of each lesson</li> <li><input type="checkbox"/> Test your Competence 11 at the end of the unit</li> </ul>

### 3.1 Important sub-headings of a Lesson plan

The most important document when planning to teach is the lesson plan.

A lesson plan is a detailed outline of how the teacher intends to carry out a specific lesson. The content of different parts of a lesson plan is explained below.

#### (a) Administrative details

These include:

Term.....	Subject.....
Date.....	Duration.....
Class.....	Class size.....

#### (b) Special Educational needs

A list of types of special educational needs to be catered for during the lesson and the number of learners in each category.

#### (c) Unit title

This refers to the broad area that is to be studied – taken from the syllabus.

#### (d) Key unit competence

This is/are the competence(s) that the learner is expected to achieve at the end of the unit.

#### (e) Title of the lesson

This is the lesson title extracted from the learning objective(s).

#### (f) Instructional objectives

This represents what the teacher anticipates students to achieve by the end of the lesson. A good instructional objective have five element, that is conditions, who, action/behaviour, content and standard or

criteria for acceptable performance.

#### (g) Plan for the class

This refers to location of the lesson i.e where the lesson will be tonight.

#### (h) Learning materials/teaching resources

These refer to any materials and apparatus that the students and the teacher will use during the lesson.

#### (i) References

These are resources consulted or used by the teacher to prepare the lesson as well as any books that the students will use during the lesson.

#### (j) Description of the teaching and learning activities

These are divided into two: teacher activities and learner activities. They describe what the teacher and the learner should do during the teaching/learning process. Further, the teacher should be cognizant of the fact that the various generic competences and the cross cutting issues should be brought out during the teaching/learning activities. Highlight these as the activities are on-going.

#### (k) Timing for each step

this section is divided into three:

- Introduction to the lesson
- Lesson development
- Conclusion of the lesson

#### (i) Introduction of the lesson

This is the beginning of the lesson. It is allocated 10 minutes in a double lesson. The teacher should motivate the students by creating problem situations that interest

students e.g. posing a question, telling an amusing but relevant story or episode, showing an object, picture or video that arouse their interest. The introduction should also if possible link what the students have already learnt with what they are going to learn.

### (ii) Lesson development

This is the main part of the lesson. It is allocated 50 minutes in a double lesson. Lesson development should mainly include the activities that students and the teacher will perform in order to achieve the stated objectives; as well as the genetic competence and the cross-cutting issues to be addressed. It is more convenient to distinguish between the students'

Here, the teacher states what went well or wrong with the delivery of the lesson.

## 3.2 Sample Competence – based lesson plan

School Name: \_\_\_\_\_ Teacher's name: \_\_\_\_\_

Term	Date	Subject	Class	Unit N°	Lesson N°	Duration	Class size
I	22/1/2018	Chemistry	S3	1	1 of 7	80 minutes	32
<b>Type of Special Educational Needs to be catered for in this lesson and number of learners in each category</b>				<ul style="list-style-type: none"> <li>• Learners with low vision (2)</li> <li>• Learners with hearing problems (3)</li> <li>• Learners with language difficulties (4)</li> <li>• Intellectually learners (5)</li> <li>• Bright learners (3)</li> </ul>			
<b>Unit title</b>		Carbon and its inorganic compounds					
<b>Key Unit Competence:</b>		To be able to relate the properties of carbon and its compounds to its uses and describe how the compounds of carbon are prepared.					
<b>Title of the lesson</b>		Allotropic forms of carbon, their properties and uses.					
<b>Instructional Objective</b>		Through observing various forms of carbon such as charcoal, diamond and graphite and by conducting individual research on allotropy and forms of carbon and finally through performing the various practical activities suggested, learners should accurately define the term allotropy and discover the various allotropes of carbon and uses.					

and teacher's activities under two columns as shown in the lesson plan below.

### (iii) Conclusion of the lesson

This is the step in which the lesson activities are tied up or consolidated to emphasize the main points i.e summarize the lesson. It is followed by assessing whether the learning objectives have been met. It is allocated the last 20 minutes of the lesson; 10 minutes for summary and 10 minutes for assessment.

### (l) Teacher self-evaluation

Here, the teacher states what went well or wrong with the delivery of the lesson and gives what he/she plans to do moving forward.

<b>Plan for this class (location: in / outside)</b>	<ul style="list-style-type: none"> <li>In the chemistry laboratory and the library</li> </ul>
<b>Learning materials (for all learners)</b>	<ul style="list-style-type: none"> <li>Various forms of carbon such as charcoal, dry cells, pencil lead, soot, among others.</li> <li>Charts showing allotropes of carbon</li> <li>Computers connected to the internet</li> <li>Large print text procedures for learners with low vision</li> </ul>
<b>References</b>	Longhorn Chemistry Senior 3 textbook, Whitten, Davis & Peck (1996) General Chemistry, computer with internet connection and any other relevant reference textbook.

<b>Timing for each step</b>	<b>Description of teaching and learning activity</b>	Generic competences and cross cutting issues to be addressed plus a short explanation
	Learners perform the practical activities, observe the samples of allotropes of carbon and conduct research on allotropy and allotropic forms of carbon.	
	<b>Teacher activities</b>	<b>Learner activities</b>

<b>Introduction 10 minutes</b>	Shows learners pictures on of their book and asks probing questions such as: <b>Sample Questions</b> 1. Identify the things in the pictures. 2. What is the relationship between them? 3. Based on your answers to the above questions, what do you think you will learn in this unit?	Learners study the pictures and answer the questions.  <b>Answers to Sample Questions</b> 1. A - Diamond rings B - Diamond, C- Charcoal, D - Dry cells, E - Drill bits. 2. They are all products of carbon. 3. Carbon and its inorganic compounds	<p><b>a) Generic competences</b></p> <p><b>1. Co-operation and interpersonal management and life skills</b> As learners interact in their groups when discussing the answers to the probing questions.</p> <p><b>2. Communication in official language</b> As learners discuss the probing questions and give answers.</p> <p><b>3. Critical thinking and problem solving skills</b> as learners think about the probing questions.</p> <p><b>b) Cross cutting issues</b></p> <p><b>1. Gender Education</b> during grouping as you put both a boy and a girl in pairs.</p> <p><b>2. Inclusive learning</b> As you give visually impaired learners large print text on the probing questions.</p>
--------------------------------	--	--	--

<p><b>Development of the lesson (50 minutes)</b></p>	<p>Activity 1.1 student's book</p> <p>Ask learners to carry out a research in the library or using the Internet.</p> <p>Ask learners to collect various forms of carbon (charcoal, soot and pencil lead) and conduct tests described in this activity.</p> <p>Guide learners to answer the study questions associated with this activity.</p> <p>Let learners collect some charcoal and prepare a dye solution.</p> <p>Assists learners to form groups depending on the class size and their ability.</p> <p>Asks learners to discuss results of the experiment above..</p>	<p>Carry out research on what allotropy is and the various allotropes of carbon and write a report</p> <p>Collect the materials and carry out the tests as describe in the activity.</p> <p><b>Answer the questions in the activity.</b></p> <p>Answers to question</p> <p>1. allotropy is the existence of a chemical element in two or more forms.</p> <p>2. Carbon and sulphur.</p> <p>3. Diamond and graphite</p> <p>Collect charcoal and the dye solution, immerse the charcoal into the dye and observe what happens.</p> <p>Form groups as per the teacher's instructions.</p> <p>Discuss their findings, come up with a report and presents it to the rest of the class .</p>	<p><b>a) Generic competences</b></p> <p><b>1. Research skills</b></p> <p>As learners find out about allotropy and the various allotropes of carbon.</p> <p><b>2. Communication in official language</b></p> <p>As learners discuss in their groups and ad they do presentations.</p> <p><b>3. Critical thinking and problem solving skills</b></p> <p>As learners conduct the experiments and as they answer the study questions after the experiment.</p> <p><b>b) Cross-cutting issues</b></p> <p><b>1. Inclusive learning</b></p> <p>As all learners irrespective of their abilities participate in the class activities and during discussions.</p> <p><b>2. Gender education</b></p> <p>As both boys and girls participate equally in all the activities during the lesson.</p> <p><b>3. Financial education</b></p> <p>As learners follow instructions, handle apparatus carefully to minimise breakage and use reagents in specified quantities to minimise wastage. All these have financial implications in terms of cost.</p> <p><b>4. Standardisation culture</b></p> <p>As learners insist on using chemicals and apparatus certified by the Rwandan Standards Boards.</p> <p><b>5. Environment and sustainability education</b></p> <p>As learners exercise caution and care when disposing by-products and wastes during experiments.</p> <p><b>6. Peace and values education</b></p> <p>Caution learners against harming one another and emphasize the need to live in harmony.</p>
--	---	---	--

<p><b>Conclusion:</b> <b>20 minutes</b></p> <p><b>(a) Summary</b></p> <p><b>(b)Assessment</b></p>	<p>Asks a volunteer learner to come and summarise what they have learnt in this lesson. Recaps by highlighting main points and correcting the learner who volunteered.</p> <p>Gives oral questions to assess achievement of lesson objectives. The questions may include:</p> <p><b>Sample questions</b></p> <ol style="list-style-type: none"> <li>1. What are allotropes?</li> <li>2. Name two amorphous and two crystalline forms of carbon.</li> <li>3. What is the most common use of: a) graphite? b) diamond? ?</li> </ol>	<p>Listen to the fellow learner and take short notes.</p> <p><b>Summary notes</b></p> <ul style="list-style-type: none"> <li>• Allotropy is the existence of an element in two or more forms in the same physical state.</li> <li>• The two allotropes of carbon are: diamond and graphite.</li> <li>• Diamond is the strongest occurring element while graphite conducts electricity.</li> <li>• Diamond is used to make drilling equipment and in making jewellery while graphite is used as a lubricant and in pencil leads.</li> </ul> <p>Listen to the teacher and correct the wrong notes taken during fellow learner presentation.</p> <p><b>Answers to sample questions</b></p> <ol style="list-style-type: none"> <li>1. Elements that exist in two or more different forms.</li> <li>2. Amorphous - soot, charcoal; crystalline - diamond, graphite.</li> <li>3. a) Graphite - pencil lead b) Diamond - making jewellery</li> </ol>	<p>a) <b>Generic competences</b></p> <p>1. <b>Communication in official language</b></p> <p>As the learner makes presentations in English language and as the others listen and ask questions. Also, as the learners write summary notes in their notebooks.</p> <p>b) <b>Cross-cutting issues</b></p> <p>1. <b>Inclusive learning</b></p> <p>As all learners i participate in the discussions.</p> <p>2. <b>Gender education</b></p> <p>As both boys and girls participate in the discussions.</p>
<p><b>Teacher self-evaluation</b></p>	<p>The lesson was succesful, however, some learners had challenges understanding what allotropy is. Remedial teaching is necessary.</p>		

### 3.3 Conclusion

This teacher's book has been written to help you guide Students to learn Chemistry in the most enjoyable and captivating manner. You are reminded to always arouse the curiosity of learners as you teach. Some things that you may do before you go for a lesson include:

- Go through the expected learning outcomes – this should help guide the manner of teaching.
- Read through the unit for the lesson in advance to get an overview of the content required.
- Form a mental picture of the teaching situation and the ways in which you will interact with students when dealing with the suggested activities.

- Collect the materials that will be needed during the lesson in advance.
- In some cases, try out the suggested activities/ experiments in advance to avoid embarrassments like the experiment failing to work during the lesson.

**Remember:** The suggested teaching activities in this book are just a guide. You may not need to follow them to the letter! Feel free to incorporate other innovative teaching methods that will help in delivering the intended content optimally.



*Refer to Learner's Book***Key Unit Competency**

After studying this unit, the learners should be able to relate the properties of carbon and its compounds to its uses and describe how the compounds of carbon are prepared.

**Learning objectives**

In competency based curriculum divides the learning objectives into three i.e.

knowledge and understanding, skills acquisition, and attitude and values.

At the end of the unit, learners should have knowledge and understanding of carbon and its inorganic compounds and have the right attitude towards natural resources, self-confidence and development of team work.

**Table 1.1: Knowledge and understanding, skills and attitudes and values to be attained**

Knowledge and understanding	Skills	Attitudes and values
<ul style="list-style-type: none"> <li><input type="checkbox"/> Explain the allotropic forms of carbon, their properties and uses.</li> <li><input type="checkbox"/> Explain the properties of carbon and its compounds.</li> <li><input type="checkbox"/> Explain the impact of carbon compounds on the environment.</li> <li><input type="checkbox"/> Explain the carbon cycle and relate it to food chain.</li> <li><input type="checkbox"/> Explain the causes hardness of water.</li> </ul>	<ul style="list-style-type: none"> <li><input type="checkbox"/> Prepare, collect and test <math>\text{CO}_2</math>.</li> <li><input type="checkbox"/> Prepare, collect and test carbonates of different metals.</li> </ul>	<ul style="list-style-type: none"> <li><input type="checkbox"/> Appreciate the importance of natural resources.</li> <li><input type="checkbox"/> Develop self-confidence during presentation.</li> <li><input type="checkbox"/> Respect of procedure during experiment.</li> <li><input type="checkbox"/> Develop a culture of working together or in groups.</li> </ul>

## Pre-requisite to this unit

Learners have learnt about carbon as an element in the periodic table in Senior one and two. They have looked at some of its reactions with other substances.

Learners have also learnt some compounds of carbon notably carbon dioxide, carbon monoxide and metal carbonates.

Review all these reactions involving carbon as you prepare learners for this unit, where they will learn about and relate the properties of carbon and its compounds to its uses and their preparation. This unit also involves the study of causes of hardness of water and the carbon cycle.

### Links to other subjects

During the lesson, strive to make learners aware of the fact that this topic is related to Agriculture and Geography in the study of natural resources. Let learners understand that this knowledge will be applied in mining and conservation of natural resources.

This topic is also related to Biology: respiration, photosynthesis and ecology where carbon cycle is key.

### Background information

Carbon is an element that forms very many compounds. Hence its chemistry and that of its inorganic compounds is important.

Carbon is in group IV, period 2 of the Periodic Table. The various forms of

carbon makes it have a variety of uses. The allotropic forms of carbon are graphite and diamond. Although they are all carbon, they have different properties and uses.

The preparation and uses of carbon dioxide is discussed together with carbonates and hydrogen carbonates. Causes of water hardness and the way to remove the hardness is discussed together with its advantages and disadvantages.

## Cross-cutting issues to be addressed

### 1. Inclusive learning

All learners should be encouraged to participate during lessons and practical experiments. Make arrangement to take care of learners with special needs. In particular learners with visual impairment should be placed in front of the classroom. Provide large print text for learners with visual impairment.

Group physically challenged learners with other learners during movement, handling of equipment, apparatus, field trips and other demanding practical activities. Furthermore, give these learners tasks they can easily handle during practical.

### 2. Gender education

Both boys and girls should participate equally in all activities. Emphasise to learners that anybody irrespective of their gender can pursue a career in any field. Give examples of role models who are successful in their career locally.

### **3. Financial education**

Emphasise the need to follow instructions, handle apparatus carefully to minimise breakage and use reagents in specified quantities to minimise wastage. All these have financial implications in terms of cost.

### **4. Standardisation culture**

Emphasise the need to use chemicals and apparatus certified by the Rwanda Standards Board (RSB).

### **5. Environment and sustainability education**

Bring to the attention of learners the fact that carbon dioxide is linked to global warming while carbon monoxide is harmful to health. Advise learners against practices such as burning of garbage, tyres and other wastes that release carbon dioxide to the atmosphere. Also, caution learners against staying in a poorly ventilated room with burning charcoal.

### **6. Peace and values education**

Emphasise to learners the importance of working harmoniously with each other during group work and class activities.

### **7. Health education**

Emphasise to learners that some inorganic carbon compounds are dangerous to organisms' life.

## **Generic competencies**

### **1. Research skills**

Guide learners on how to find information regarding various topics, on how to come up with summarised notes from a large body of text and on how to do internet searches for the various content areas they are looking for.

### **2. Communication in English**

Communication in English will be improved when learners freely participate in the discussions and presentations. Encourage all learners irrespective of their abilities to participate in group discussions, during presentations by asking questions and during question and answer sessions to either introduce or wrap up the lessons.

### **3. Cooperation and interpersonal management and life skills**

During group discussions and pair-work let learners engage one another by giving a chance for all to participate. Also, during group presentations, you can allow rotational presentations within the group members. Gifted learners should help in coming up with presentation content as slow learners contribute.

Note: You should allow slow learners to do presentations as well and correct them where they go wrong. Advise learners to appreciate the different abilities of their group members and accommodate each other's views.

### **4. Critical thinking and problem solving skills**

This competence will be developed by

learners as they answer the probing questions at the beginning of this unit and as they discuss the results of the various practical activities. Guide learners to discover for themselves inorganic compounds of carbon. This competence will also come about as learners think about their findings in the activities and as they give out their suggestions.

## 5. Lifelong learning skills

Good environmental management and realising the importance of natural resources builds the economy of a country.

### Key words in this unit and their meanings

- **Allotropes** – Are different forms of the same element under the same physical state.
- **Allotropy** – Is the existence of an element in more than one form under the same physical state.
- **Amorphous** – of a substance without a clearly defined shape or form.
- **Carbon cycle** – The series of processes by which carbon compounds are presented and circulate in the environment.
- **Carbonate** – a salt of the anion  $\text{CO}_3^{2-}$ , typically formed by reaction of carbon dioxide with bases.
- **Environment** – The immediate surroundings of an organism.
- **Hard water** – water that has dissolved salts (sulphate or

hydrogen carbonates) of calcium and magnesium.

- **Refrigerant** – a substance used for cooling (refrigeration).
- **Soft water** – water which has relatively low concentration of calcium carbonate and other ions.
- **Solvay process** – industrial process for the production of sodium carbonate.

### Guidance on the brain teaser

In this topic, you will teach about carbon and its inorganic compounds. As a way of introducing these concepts, refer learners to the pictures in Fig 1.1 in the learner's book. The pictures show various products or products parts made from carbon and its inorganic compounds. Allow learners in groups to discuss the products. The groups should be constituted based on learner abilities and class size. Let them give answers to the probing questions associated with the pictures.

Pictures on Fig 1.1 represents diamond, diamond rings, charcoal, tool bits and batteries. All these products are made from carbon and are used for various purposes. Guide the learners to discover what they will learn in this topic based on these pictures. Further, emphasise the need for taking this topic seriously in the course of the lessons as it can lead to environmental awareness.

## Attention to special educational needs

Support for multi ability learning	Support for special needs learning
<ul style="list-style-type: none"> <li><input type="checkbox"/> Gifted learners to be given heavy tasks requiring more critical thinking while slow learners are given tasks which they can manage such as collecting materials for use during practicals among others.</li> <li><input type="checkbox"/> Both gifted and slow learners to be given equal opportunity to lead in group discussions and to do presentations of group findings to the rest of the class.</li> <li><input type="checkbox"/> Ensure all learners respect other's views irrespective of their shortcomings or talents.</li> </ul>	<ul style="list-style-type: none"> <li><input type="checkbox"/> Allocate gifted learners to help fellow learners with special needs.</li> <li><input type="checkbox"/> Provide braille for blind learners and if available large print text to learners with seeing difficulties.</li> <li><input type="checkbox"/> Also, arrange learners such that shortsighted ones are at the front and long-sighted ones are at the back.</li> </ul>

## List of lessons

Lesson Number	Lesson title	No. of periods
1	Allotropic forms of carbon, their properties and uses	2
2	Chemical properties of carbon	2
3	Properties, preparation and uses of carbon dioxide	3
4	Properties, preparation and uses of carbonates and hydrogen carbonates	2
5	Impact of carbon compounds on the environment	1
6	Hard and soft water	2
7	The carbon cycle	1
8	End of unit assessment test	2

## 1.1: Allotropes of carbon, their properties and uses

*Refer to Learner's Book*

**Lesson 1: Definition of allotropes, allotropic forms of carbon, their physical properties and uses (To be covered in two periods)**

**Specific objectives**

By end of the lesson, learners should be able to:

- Define allotropes and allotropy.
- State the allotropic forms of carbon and give their physical properties.

- State uses of carbon.

### Preparation for the lesson

1. This lesson will be taught in two periods and will involve group work, research work and note taking. Put learners in groups of four during group work.
2. Get diagrams and pictures of the allotropes of carbon and text books for reference in class.
3. Carry out your own research using various text books and on the internet regarding allotropy to equip you with relevant information during the lesson.

### Suggested teaching aids

- Text books and charts on allotropes of carbon
- Computer connected to Internet
- Chalkboard diagrams
- Dictionary

### Improvisation

- You may come up with your own charts drawn on manila papers if your school does not have charts on allotropes of carbon.
- Learners can mould structure of graphite and diamond using plasticine and wires.

### Pre-requisite lesson

You may begin the lesson by asking learners what they know about carbon, where it is found, its uses and its position in the Periodic Table.

### Suggested teaching and learning activities

1. Organise learners into convenient groups according to the resources available, for Activity 1.1 in the Learner's book. Ensure that learners are cooperating and working together.
2. Provide them with dictionaries, textbooks or computers with internet connectivity. Let them carry out the activity as outlined in the learner's book. Guide the learners on how to summarise the requested work from books or internet to develop their research skills.
3. Ask each group to present its findings. Use their findings to explain what allotropy is and elements that exhibit allotropy. Narrow down to carbon as they take notes. Allow different learners to present their work in order to develop their communication skills.
4. Organise learners into convenient groups according to the resources available, for Activities 1.2 and 1.3 in the Learner's book respectively.
5. Provide them with the required materials and guide them to follow the procedure as outlined in the learner's book.
6. In their groups let them discuss their findings, write a report and present it in class.
7. Use their presentations to discuss the

crystalline and non-crystalline forms of carbon and their properties as outlined in the Learner's book. Use charts and diagrams to illustrate this.

- Let the learners appreciate the purpose to respect procedure during practical activities and appreciate development of team work in group activities.
- At this point you can give a summary of the chemical properties of carbon and reinforce the uses of carbon.
- Instruct learners to attempt questions in Self-evaluation Tests 1.1 and 1.2 in the Learner's Book respectively.

### Synthesis

This lesson introduces learners to allotropy and allotropic forms of carbon. The activities carried out during the lesson will help learners understand the allotropic forms of carbon, their properties, structure and uses. This will enable them to appreciate the importance of natural elements.

### Suggested lesson assessment

Assess whether the learning objectives of the lesson were met by asking the following questions:

- What are allotropes?

*(Ans: The property of some chemical elements to exist in two or more different forms, in the same physical state)*

- Name and draw the allotropic forms of carbon

*(Ans: Diamond and graphite, refer to the Learner's book for structures)*

- Relate the properties of allotropes of carbon to its uses.

*(Diamond- hardest natural substance due to strong covalently bonded carbon atoms in its structure. Graphite – conducts electricity due to delocalised electrons in its structure.)*

### Answers to Self-evaluation Test

#### 1.1

Refer to Learner's Book

- The existence of two or more different physical forms of a chemical element.
- Carbon and sulphur.
- Carbon - Diamond and graphite  
Sulphur-Rhombic and Monoclinic Sulphur.
- | Colour | Texture |
|--------|---------|
| Black  | Soft    |
- Graphite .
- Substances such as wood is burnt in limited air.
- Allow flow of electrons i.e. conducts electricity.

## Answers to Self-evaluation Test 1.2

Refer to Learner's Book

1. Carbon is burning with limited oxygen to form soot.
2. Charcoal, soot.
- 3.

A	B
Amorphous carbon	Non-crystalline form of carbon
A good conductor of electricity	Graphite
Graphite	Made of hexagonal layers joined by weak Van der Waal forces of attraction.
Uses all electrons for bonding	Diamond

4. a) Diamond is hard due to its carbon atoms forming strong covalent bonds while graphite carbon atoms forms in layers and the layers are bonded by weak Van der Waals forces.  
b) Graphite has delocalised electrons while in diamond all the carbon electrons are used in bonding.
5. Charcoal is locally available obtained from trees therefore depletes forests.
6. Charcoal burning introduces harmful gases into the atmosphere. It is linked to global warming.

7. Bonding in graphite enables it to be in layers which slide while bonding in diamond does not.

## Lesson 2: Chemical properties of carbon (To be covered in two periods)

Refer to Learner's Book

### Specific objectives

By the end of the lesson, the learners should be able to explain the chemical properties of carbon.

### Preparation for the lesson

The lesson will be taught in two periods. This is a practical activity that will involve experiments in this laboratory. Prepare for the availability of reagents and apparatus to be used. Pretest the experiments. The learners should be organised in the class in a way that will encourage the teaching and learning activities suggested.

### Teaching aids

Bunsen burner, learner's text books, gas jar, deflagrating spoon, Iron (II) oxide, conc. Nitric acid, bottle tops, conc. Sulphuric acid, tongs, charcoal.

### Improvisation

Charcoal and bottle tops can be used in this experiment where the supply of commercial carbon and deflagrating spoon is not available.

### Prerequisite for the lesson

Introduce the lesson by asking learners to name chemical properties of carbon they are aware of.



Learners should come up with some properties. From their responses, select the correct ones and tell them they are going to investigate these properties in an experiment.

### **Suggested teaching and learning activities**

1. Organise learners into convenient groups size according to availability of resource, for example in groups of four students. They should carry out experiments 1.5, 1.6, 1.7 and 1.8 in the Learner's Book in the various groups. Teacher should ensure that learners are working in their groups showing cooperation and interpersonal skills.
2. Guide learners in setting up apparatus and instruct them to follow the laid down procedures for each experiment.
3. Inform them to write down their observations and results in their notebooks.
4. Allow learners to discuss their findings, write a report and present their findings in class to develop communication skills.
5. Use their presentation to discuss the chemical properties of carbon as outlined in the learner's book as they take notes.
6. Let the learners appreciate the purpose to respect procedure during practical activities and appreciate development of team work in group

activities. This allows cooperation and interpersonal skills to be developed.

7. At this point the teacher can give a summary of the chemical properties of carbon.
8. End the lesson by instructing learners to attempt the questions in Self-evaluation Tests 1.3.

### **Synthesis**

The learners should understand that carbon as an element has various chemical properties, for example, as a reducing agent. It can also react with other substances as shown in the activities. The properties of carbon influence its utilisation in various areas our daily lives.

### **Suggested lesson assessment**

Assess whether the learning objective of the lesson were met by asking questions such as:

1. Name common source of carbon in our daily life.  
(Ans: carbon dioxide)
2. Carbon reacts with:
  - (i) Iron III oxide
  - (ii) Nitric acid

Explain the property of carbon shown in each of the reactions.

(Ans: Reducing agent and oxidising properties.)

3. State the physical properties of the two major allotropes of carbon.

*(Ans: Diamond is the hardest naturally occurring substance, and graphite is one of the softest known substances.)*

4. State three uses of carbon.

*(Fuels such as coal or charcoal, carbon as graphite is a good lubricant, carbon is a key component of steel)*

### Answers to Self-evaluation Test

#### 1.3

Refer to Learner's Book

1. CO<sub>2</sub> loses oxygen while C gains oxygen.

2. a) (i) Plenty supply of oxygen

(ii) Insufficient oxygen

b) Exothermic reaction

3. i)  $C(s) + 4HNO_3(l) \rightarrow CO_2(g) + 4NO_2(g) + 2H_2O(l)$

- ii)  $C(s) + 2H_2SO_4(l) \rightarrow CO_2(g) + 2SO_2(g) + 2H_2O(l)$

### Lesson 3: Preparation, properties and uses of carbon dioxide (To be covered in three periods)

Refer to Learners Book

#### Specific objectives

By the end of this lesson, the learner should be able to prepare, collect and test for carbon dioxide and be able to describe the properties of carbon dioxide.

#### Preparation for the lesson

This lesson will be taught in three periods. It will involve the study of compounds of carbon i.e. carbon dioxide. The lesson also involve activities 1.8 and 1.9 on the properties of carbon dioxide. It also involves discussions and research work. You will guide the learners in these activities and assess the learners' achievement as they make their presentations. Therefore, you are required to pretest the experiments and set the laboratory in advance and organise the class in a way that will promote the teaching and learning activities suggested.

#### Suggested teaching aids

Bunsen burner, learners textbooks, funnel, marble chips, dilute hydrochloric acid, round bottomed flask, gas jar, lime water, test tubes, candle, magnesium, charcoal, sodium hydroxide, charts.

#### Prerequisite for the lesson

Introduce the lesson by asking learners to name common compounds of carbon. From their answers discuss with them the oxides of carbon, carbonates and hydrogen carbonates as outlined in the students book as they take notes.

Show them pictures of the activities that increase carbon dioxide in the atmosphere in the Learner's book. They should appreciate the need to come up with measures to mitigate their effects to the environment through conservation.

## Suggested teaching and learning activities

1. Organise learners into convenient groups according to resources available to carry out Activities 1.9 and 1.10 in the Learner's Book respectively.
2. Instruct them to follow the procedures as laid out in the Learner's book carefully. Assign learners who are challenged such as visual impaired, below average learner and physically challenged to other learners to assist them.
3. The carbon dioxide collected in activity 1.9 should be stored to be used in activity 1.10.
4. Inform learners to discuss in groups the study questions in each experiment, note down their findings and write a report. Discussion in their groups allows cooperation and interpersonal skills development.
5. Allow learners to present their reports in class. Use their presentations to discuss the physical and chemical properties of carbon dioxide and its uses. Use diagrams in the learners book to illustrate this. Presentation and communication skills will be developed through allowing learners to present especially those who are shy.
6. End the lesson by instructing learners to attempt Self-evaluation Test 1.4 and 1.5 in the learner's book respectively.

## Synthesis

This lesson should create awareness of how carbon dioxide can be prepared in the laboratory and describe the properties of carbon dioxide and its uses. Learners should also appreciate the fact that although carbon dioxide is useful, it also leads to pollution of the environment if its levels build up in the environment beyond unaccepted limits.

## Suggested lesson assessment

Assess whether the learning objective of the lesson was met by asking questions such as:

1. Name the reagents used to prepare carbon dioxide in the laboratory.  
*(Calcium carbonate and dilute hydrochloric acid)*
2. Write an equation for the laboratory preparation of carbon dioxide.  
$$[CaCO_3 (s) + 2HCl (aq) \rightarrow CaCl_2(aq) + CO_2(g) + H_2O(l)]$$
3. Describe the properties of carbon dioxide.  
*(Carbon dioxide is colourless. At low concentrations, the gas is odourless. At higher concentrations it has a sharp, acidic odour)*
4. State the uses of carbon dioxide.  
*(Fire extinguisher, refrigeration, in carbonated drinks as preservative)*
5. Describe the test for carbon dioxide.  
*(Passing the gas through lime water which turns milky if positive).*

## Answers to Self-evaluation Test

### 1.4

Refer to Learner's Book

1. Carbon monoxide prevents blood from combining with oxygen in the body tissues leading to suffocation.
2. (a) The gradual increase in the overall temperature of the Earth's atmosphere generally attributed to the greenhouse effect caused by increased levels of carbon dioxide, chlorofluorocarbons (CFCs), and other air pollutants (greenhouse gases).  
(b) Increase in the level of greenhouse gases due to human activities. Note: Assess each learner's responses accordingly.  
(c) Minimising release of greenhouse gases such as carbon dioxide, sulphur dioxide, CFCs and methane into the atmosphere.

## Answers to Self-evaluation Test

### 1.5

Refer to Learner's Book

1. Colourless, odourless gas, denser than air, slightly soluble in water.
2.  $2\text{NaOH}(\text{aq}) + \text{CO}_2(\text{g}) \rightarrow \text{Na}_2\text{CO}_3(\text{aq}) + \text{H}_2\text{O}(\text{l})$
3. Turns milky or cloudy. Equation of the reaction is:

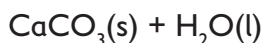
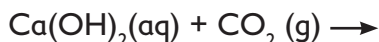

4. The magnesium continues to burn in the carbon dioxide forming some black specks of carbon and white solid (magnesium oxide).

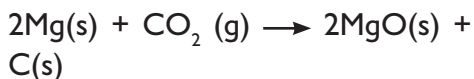

5. a) Red litmus paper turned blue.  
b)  $\text{MgO}(\text{s}) + \text{H}_2\text{O}(\text{l}) \rightarrow \text{Mg}(\text{OH})_2(\text{aq})$

## Lesson 4: Preparation, properties and uses of carbonates and hydrogen carbonates (To be covered in two periods)

Refer to Learner's Book

### Specific objective

By the end of this lesson, the learners should be able to prepare, state the properties and uses of carbonates and hydrogen carbonates.

### Preparation for the lesson

The lesson will be taught in three periods. It will mainly involve activities carried out by learners as you engage them in a discussion regarding the activities and assessing learners' achievements.

Let the learners carry out the experiments or activities with your guidance. Make sure the laboratory is orderly and incident free.

### Suggested teaching aids

Bunsen burner, calcium chloride, sodium carbonate, filter funnel, filter paper,

conical flask, beakers, stirring rod, charts showing limestone, soda ash extraction etc.

### **Pre-requisite for the lesson**

Learners are already conversant with apparatus used in the laboratory. Ask them to name some apparatus that will be used during preparation of carbonates and hydrogen carbonates. They should be able to name some. Remind them of the need to handle apparatus with care and follow procedures.

### **Suggested teaching and learning activities**

1. Introduce the lesson by grouping learners into convenient groups for Activities 1.11 and 1.12 in the Learner's Book respectively. Emphasise on group work to promote cooperation and interpersonal skills development.
2. Assist learners in setting up the apparatus. Then instruct them to follow the procedures as outlined in the experiments. Physically challenged learners can be helped to set up the apparatus.
3. The experiments will be done in rotation within the groups. Check that each and every learner participates in handling the apparatus and following the procedures carefully.
4. Inform learners to note down their observations and results.
5. Let them discuss the study questions in their respective groups. They will write a joint report and present it to the rest of the class. Teacher to do the Round Robin to check if all learners are participating to promote team work spirit.
6. Use their presentations to discuss the preparation of metal carbonates and hydrogen carbonate as outlined in the learner's book as they take notes.
7. Inform learners that sodium hydrogen carbonate is important due to its many uses hence prepared in large quantities industrially using the **Solvay process**.
8. Using charts and diagrams discuss the steps involved in the Solvay process, uses of sodium hydrogen carbonate and the environmental issues involved.
9. In their respective groups organise learners to carry out experiments 1.13, 1.14 and 1.15 in the learner's book respectively. Groups encourage team spirit which promotes cooperative and interpersonal skills learning.
10. Guide them in carrying out the experiments as outlined in the Learner's Book. They should record their results in a table format as suggested.
11. Caution them to be careful during

the experiments because it involves heating.

- Let them discuss the results obtained and observations made in their respective groups and do a presentation of their findings in class. You should remember that during presentation is when learners develop communication skills and presentation skills hence each student should be encouraged to present.
- Thereafter have a class discussion on the chemical properties of carbonates and hydrogen carbonates as outlined in the Learner's Book as they take notes.
- Instruct learners to carry out the research activity suggested in the Learner's Book. They should write a report and present it to you for assessment.
- End the lesson by instructing learners to attempt Self-evaluation Test 1.6.

### Synthesis

This lesson aims at giving learners the knowledge on preparation, properties and uses of carbonates and hydrogen carbonates. It also touches on the manufacture of sodium hydrogen carbonate which is a very important substance that has many important uses.

### Suggested lesson assessment

Assess whether the learning objectives of the lesson are being by asking questions such as:

- Name two examples of carbonates and two examples of hydrogen carbonates.

*(Ans: Sodium carbonate and potassium carbonate, sodium hydrogen carbonate and potassium hydrogen carbonate.)*

- Describe how carbonates are prepared.

*(Refer to Activity 1.11 in the learner's book.)*

- When Zinc carbonate is heated we obtain.....and.....

*(Ans: Zinc oxide and carbon dioxide)*

- When a hydrogen carbonate is heated we obtain..... and.....

*(Ans: Metal carbonate, water and carbon dioxide)*

### Answers to Self-evaluation Test

#### 1.6

*Refer to Learner's Book.*

- The solution turns milky or white precipitate is formed.
  - $$\text{ZnCO}_3(\text{s}) + 2\text{HNO}_3(\text{aq}) \rightarrow \text{Zn}(\text{NO}_3)_2(\text{aq}) + \text{CO}_2(\text{g}) + \text{H}_2\text{O}(\text{l})$$
$$\text{Ca}(\text{OH})_2(\text{aq}) + \text{CO}_2(\text{g}) \rightarrow \text{CaCO}_3(\text{s}) + \text{H}_2\text{O}(\text{l})$$
  - Refer to Fig: 1.25 in the learner's book.
- White solid turns yellow.
  - The solution turns cloudy or milky.

- c. i.  $\text{PbCO}_3(\text{s}) \xrightarrow{\text{heat}} \text{PbO}(\text{s}) + \text{CO}_2(\text{g})$   
 ii.  $\text{Ca}(\text{OH})_2(\text{aq}) + \text{CO}_2 \longrightarrow \text{CaCO}_3(\text{s}) + \text{H}_2\text{O}(\text{l})$
3. a) Sodium carbonate, potassium carbonate, ammonium carbonate.  
 b) Calcium carbonate, zinc carbonate.
4. a) A - Magnesium carbonate  
 C - Sodium carbonate  
 b) Ammonia gas is produced first then carbon dioxide later.
5. a) Carbon dioxide, the solution likely contains HCl which reacts with egg shell ( $\text{CaCO}_3$ ) to release  $\text{CO}_2$ .  $\text{CO}_2$  turned lime water milky.  
 b) Passing the gas through a solution of calcium hydroxide.  
 c) Carbon dioxide: by passing it through calcium hydroxide.
6. a)  $\text{Na}_2\text{CO}_3(\text{aq}) + \text{H}_2\text{SO}_4(\text{aq}) \longrightarrow \text{Na}_2\text{SO}_4(\text{aq}) + \text{H}_2\text{O}(\text{l}) + \text{CO}_2(\text{g})$   
 b)  $2\text{HCl}(\text{aq}) + \text{Na}_2\text{CO}_3(\text{aq}) \longrightarrow 2\text{NaCl}(\text{aq}) + \text{CO}_2(\text{g}) + \text{H}_2\text{O}(\text{l})$   
 c)  $\text{Na}_2\text{CO}_3(\text{aq}) + 2\text{HNO}_3(\text{aq}) \longrightarrow 2\text{NaNO}_3(\text{aq}) + \text{CO}_2(\text{g}) + \text{H}_2\text{O}(\text{l})$   
 d)  $\text{CaCO}_3(\text{s}) + \text{H}_2\text{SO}_4(\text{aq}) \longrightarrow \text{CaSO}_4 + \text{H}_2\text{O} + \text{CO}_2(\text{g})$   
 e)  $2\text{HCl}(\text{aq}) + \text{NaHCO}_3(\text{aq}) \longrightarrow 2\text{NaCl}(\text{aq}) + \text{CO}_2(\text{g}) + \text{H}_2\text{O}(\text{l})$

7. a) Zinc carbonate is a white powdery solid. When it is heated strongly, it starts to turn yellow and decomposes - carbon dioxide gas is evolved, which forms a white precipitate with lime water. The yellow solid left behind in the test-tube is hot zinc oxide. As the hot (zinc oxide) cools, it turns white in colour.



- b) The green copper (II) carbonate solid turns into black copper (II) oxide.

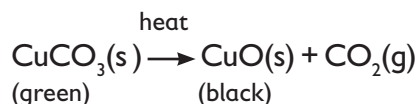

- c) When white lead carbonate is heated, it decomposes forming yellow lead oxide and carbon dioxide.



### Lesson 5: Environmental issues of carbon dioxide and carbon monoxide (To be covered in one period)

*Refer to learner's Book*

#### Specific objectives

By the end of this lesson, learners should be able to explain the impact of carbon dioxide and carbon monoxide in the environment.

### Preparation for the lesson

The lesson will be taught in one period. It will mainly involve activities being carried out by learners as the teacher engages learners in a discussion regarding the activities and assessing learners achievements. You will assist learners in collecting materials required for Activity 1.16.

### Suggested teaching aids

Charts on toxicity of carbon monoxide, learner's textbooks, computers, thermometer, beakers and a large glass beaker.

### Pre-requisite for the lesson

Ask learners how air pollution can be noticed when introducing the lesson. Tell the learners that it is hard to detect some air pollutants but their effects can be felt.

### Suggested teaching and learning activities

1. Begin the lesson by learners carrying out Activity 1.16 in Learner's Book.
2. Organise learners into convenient groups, let them follow the procedure as laid out in the activity. This encourages team work which promotes cooperation and interpersonal skills development.
3. They will discuss the results in pairs and present their conclusions to you for assessment.
4. Thereafter have a class discussion on the effects of carbon dioxide

and carbon monoxide on the environment as outlined in the Learner's Book, as they take notes.

5. Instruct learners to attempt questions in Self-evaluation Test 1.7.

### Synthesis

This lesson exposes learners to the knowledge of toxicity of carbon monoxide and carbon dioxide, emphasise why charcoal should not be left burning in a room with poor ventilation.

Emphasise the need to conserve the environment and manage natural resources efficiently.

### Suggested lesson assessment

Assess whether the learning objectives of the lesson have been met by asking questions such as:

1. What is the effect of carbon monoxide on the environment?

*(Ans: It is a poisonous gas to the health of organisms. In human beings it leads to suffocation.)*

2. Which condition leads to production of carbon monoxide?

*(Ans: Limited supply of oxygen during combustion of carbon.)*

### Answers to Self-evaluation Test

#### 1.7

Refer to Learner's Book

1. Breathing carbon monoxide leads to suffocation which can cause death.



2. Gradual increase in the overall temperature of the Earth's atmosphere generally attributed to the greenhouse effect caused by increased levels of carbon dioxide, chlorofluorocarbons and other pollutants in the atmosphere.
3. Carbon dioxide, methane, nitrous oxide.
4. B (Carbon monoxide)
5. B
6. Carbon dioxide

### **Lesson 6: Hard and soft water (To be covered in one period)**

*Refer to Learner's Book*

#### **Specific objectives**

By the end of this lesson, learners should be able to differentiate between hard and soft water.

#### **Preparation for the lesson**

The lesson will be taught in two periods. The lesson will involve a practical activity of differentiating between hard and soft water. Assist learners in collecting the required materials. Pretest the experiment in advance and organise the laboratory.

#### **Suggested teaching aids**

Samples of hard and soft water from different sources, learners text books, computers, bar soap, basins and dirty pieces of cloth.

#### **Pre-requisite for this lesson**

Learners use water daily in their lives. Ask them if they have noticed any difference in the quality of water they use and show them how they can identify/notice the change.

#### **Suggested teaching and learning activities**

1. Introduce the lesson by asking learners what they know about hard and soft water. Use probing questions about different sources of water.
2. Organise learners into convenient groups to carry out Activity 1.16 in the Learner's Book. Encourage group work which promotes cooperation and interpersonal skills development.
3. Instruct them to follow the procedure as laid down in the experiment.
4. They will discuss the results in pairs and present their conclusion to the teacher for assessment.
5. Thereafter have a class discussion on the difference between hard and soft water as outlined in the Learner's Book, as they take notes. During discussion of the differences, learners will develop critical thinking skills.
6. Discuss the various techniques employed to remove water hardness. Use equations suggested to drive the point home. Development of critical thinking and problem solving skills

during forming of equation.

7. Thereafter tackle the advantages and disadvantages of hard water as outlined in table 1.4 in the Learner's Book. Emphasise need to avoid use of excess fertilisers and pesticides which may lead to contamination of water bodies with ions that make water hard. This is as a cross-cutting issue on environment and sustainability.
8. Instruct learners to attempt questions in Self-evaluation Test 1.8 in the Learner's Book.

### Synthesis

This lesson is about differentiating hard and soft water. Emphasise the need for learners to appreciate that both hard and soft water have their merits and demerits and their occurrence in environment. They should also appreciate the need to conserve and reuse water efficiently.

### Suggested lesson assessment

Assess whether the learning objectives of the lesson have been met by asking questions such as:

1. What is meant by water hardness?  
(Ans: Hard water is high in dissolved minerals, both calcium and magnesium ions.)
2. Name the types of water hardness.

(Ans: Permanent water hardness and temporary water hardness.)

3. State the advantages and disadvantages of hard water.

(Ans: Advantages: Contains essential minerals for body growth and development, prevents lead poisoning in pipes, forms animal shells.)

Disadvantages: wastes soap, forms scum, boiler scale.)

### Answers to Self-evaluation Test

#### 1.8

Refer to Learner's Book

1. Hard water does not lather easily with soap while soft water does.
2. a) Boiling decomposes dissolved hydrogen carbonates (temporary water hardness) to their respective carbonates, for example:  $\text{Mg}(\text{HCO}_3)_2(\text{aq}) \rightarrow \text{MgCO}_3(\text{s}) + \text{CO}_2(\text{g}) + \text{H}_2\text{O}(\text{l})$   
b) Washing soda precipitates carbonates, for example:  
 $\text{MgSO}_4(\text{aq}) + \text{Na}_2\text{CO}_3(\text{aq}) \rightarrow \text{MgCO}_3(\text{s}) + \text{Na}_2\text{SO}_4(\text{aq})$
3. Hard water contains minerals such as calcium and phosphorus which are good for teeth and bone development while soft water lathers easily with soap.
4. Temporary hardness
5. Hard water

## **Lesson 7: The carbon cycle (To be covered in one period)**

*Refer to Learner's Book*

### **Specific objectives**

By the end of this lesson, learners should be able to explain what a carbon cycle is.

### **Preparation for the lesson**

The lesson will be taught in one period. The teacher will organise discussion among the learners and assist them to do presentation of their points. Organise to have a chart having the carbon cycle or make one from available resources.

### **Suggested teaching aids**

Charts on carbon cycle, learner's text books, and computer simulation.

### **Pre-requisite for this lesson**

Learners are aware of Newtons Law of Conservation that states that matter can neither be created nor destroyed but can only be transformed from one form to another. Remind them of this law as you explain the cycling of carbon in nature. Ask learners to explain what water cycle is and relate with carbon cycle.

### **Suggested teaching and learning activities**

1. Begin the lesson by asking learners to do the study questions in Learner's Book.
2. Organise learners into pairs, let them answer the questions therein. This promotes team work, cooperation and interpersonal skills development.

3. They will discuss the results in pairs and present their conclusion to you for assessment.
4. Inform them to come up with a chart to show how carbon cycle occur within their surrounding. This will help develop critical thinking and problem solving skills in learners.
5. Thereafter, have a class discussion on the carbon cycle as outlined in the Learner's Book, as they take notes.
6. Use a chart and equations to illustrate the processes involved.
8. End the lesson and topic by instructing learners to attempt in questions in Self-evaluation Test 1.9 and Test your Competence 1 in the Learner's Book respectively.

### **Synthesis**

This lesson is about the carbon cycle and the processes involved. Let learners appreciate the processes involved in the carbon cycle and their contribution to the well-being of the planet. Emphasise the need to conserve the environment and manage natural resources efficiently.

### **Suggested lesson assessment**

Assess whether the learning objectives of the lesson have been met by asking questions such as:

1. What is carbon cycle?

*(Ans: The series of processes by which carbon compounds are interconverted*

and  $\text{CO}_2$  released in to the environment, as well as activities that use up  $\text{CO}_2$  from the environment.

2. Which processes remove carbon in the air?

[Ans: Photosynthesis, dissolution in water.] (formation of acid rain.)

## Answers to Self-evaluation Test

### 1.9

Refer to Learner's Book

1. Carbon forms part of organisms, initiator of food chain but some of its compounds such as CO and  $\text{CO}_2$  harm the environment in general.
2. Oxygen.
3. Too much carbon dioxide in the environment leads to global warming while too little will affect plants during photosynthesis.
4. Photosynthesis and dissolution in water.
5. Respiration and photosynthesis.

## Summary of the unit

Use the suggested activities and suggested teaching approaches in the lessons to ensure that learners accurately describe the properties of carbon and its compounds and relate them to the various uses of carbon. Emphasise the need for learners to appreciate carbon as a natural resource.

## Additional Information for the teacher

Some information that you may find relevant in this topic are given below.

### A. Other allotropes of carbon

1. The **fullerenes** are recently-discovered allotropes of carbon named after the scientist and architect Richard Buckminster Fuller. They are molecules composed entirely of carbon, which take the form of a hollow sphere, ellipsoid, or tube. Spherical fullerenes are sometimes called Bucky balls, while cylindrical fullerenes are called buck tubes or nanotubes.

Fullerenes are similar in structure to graphite, which is composed of a sheet of linked hexagonal rings, but they contain pentagonal (or sometimes heptagonal) rings that prevent the sheet from being planar.

2. **Carbon nanotubes** are cylindrical carbon molecules with novel properties that make them potentially useful in a wide variety of applications (e.g., nano-electronics, optics, materials applications, etc.). They exhibit extraordinary strength and unique electrical properties, and are efficient conductors of heat. Inorganic nanotubes have also been synthesised.
3. **Glassy carbon** is a class of non-graphitizing carbon which is widely used as an electrode material in electrochemistry, as well as for

high temperature crucibles and as a component of some prosthetic devices.

## **B. Carbonates**

In nature, carbon atoms join with oxygen to form the carbonate ion,  $\text{CO}_3^{2-}$ . These ions combine with metal cations to form carbonate minerals. These minerals are commonly formed in sedimentary and oxidizing environments.

The carbonates fall into three groups: the calcite group, the dolomite group, and the aragonite group. The copper carbonate minerals, azurite and malachite, are the only carbonates of economic importance. Minerals of the carbonate class:

- Are transparent.
- Are lightly-coloured with a white streak.
- Have average to above average specific gravity.
- Are soft with good to perfect cleavage.
- Soluble in acidic solutions.

## **C. Carbon moves between sources and sinks**

One important aspect of the carbon cycle is the speed with which carbon moves from a carbon source to a carbon sink and then back again. Some living things grow and decompose more quickly than others. For example, living things with shells, like oysters or snails, take a longer time to decompose than slugs or tomatoes. The rate of

decomposition, and the resulting release of carbon, can be hastened by the actions of specialised microscopic and macroscopic plants and animals, called “decomposers,” that break down plant and animal matter. The decomposition process ends up creating carbon dioxide and other gases, such as methane. Plant and animal growth and decomposition occur simultaneously, all the time. For example we see live trees growing, and leaf litter and downed trees rotting in the same forest.

While a portion of the total amount of carbon present on the earth’s surface runs through the carbon cycle relatively quickly, transitioning from atmospheric carbon dioxide to plant and animal matter, and back into atmospheric carbon dioxide occurs within hundreds of years, another portion of the carbon is caught up in long-lived and stable carbon sinks. Examples of these stable sinks include: sub-surface hydrocarbon reservoirs from which oil and gas are produced, and coal formation takes place.

## **D. Natural resources**

Ever since the earth was inhabited, human beings and other life forms have depended on things that exist freely in nature to survive. These things include water (seas and fresh water), land, soils, rocks, forests (vegetation), animals (including fish), fossil fuels and minerals. They are called Natural Resources and are the basis of life on earth.

All these mentioned above are natural, and they exist in nature. No human

created them. We tap into their supply to survive and also to function properly. Natural resources are all connected in a way. Therefore if one is taken away, it will affect the supply or quality of all others. For example, if water is eliminated from an area, the vegetation, soils, animals and even the air in that area will be affected negatively.

Natural resources can be consumed directly or indirectly. For instance, humans depend directly on plants for food, biomass, health and increased living comfort. Indirectly plants act as climate control, flood control, storm protection and nutrient cycling.

### **E. Raw materials**

Sometimes, natural resources can be used as raw materials to produce something. For instance, we can use a tree from the forest to produce timber. The timber is then used to produce wood for furniture or pulp for paper and paper products. In this scenario, the tree is the raw material.

Every item in your home was made from a raw material that came from a natural resource. The tea mug, electricity at home, bread, clothes, you name them: each of them came from a natural resource. Natural resources come in many forms. It may be a solid, liquid or gas. It may also be organic or inorganic. It may also be metallic or non-metallic. It may be renewable or non-renewable.

### **F. Greenhouse gases**

The atmosphere is made up of many different gases. Several gases have the ability to reflect the sun's energy radiating from the earth back to the earth as heat. The gases with this capability are known as "greenhouse gases" (GHGs). The main GHGs are water vapour, carbon dioxide, methane, and nitrous oxide. Without some level of GHGs in the atmosphere, the earth would be much colder than it is and life on this planet would be much different.

GHGs are produced both naturally and by human activity. Most scientists believe that the increase of human-generated GHGs, in particular, the relatively rapid increase in carbon dioxide concentrations beyond what is considered a normal or natural level, is the primary cause of currently observed anthropogenic (human-induced) global warming. Global warming can be defined as a long-term increase in the average temperature of the near surface of the earth's atmosphere. The primary reason for the large increase in carbon dioxide concentrations in the atmosphere over the last few hundred years is the increased use of fossil fuels, which release significant quantities of carbon dioxide when they are burned. Another cause for the increase is land use changes, such as the harvesting of forests in the tropics (because the harvested trees are no longer available to take in carbon dioxide) or intensive agricultural practices that can lead to the loss of carbon from soil.

## End of unit assesment

This section is divided into two parts:

- Answers to test your competence 1
- Additional exercises for unit assesment ( consolidation exercises)

### a) Answers to Test your Competence I

Refer to Learner's Book

1. Diamond and graphite, soot and charcoal.
2. A - Calcium carbonate  
B - Calcium hydrogen carbonate  
C - Carbon dioxide

(b) By passing the gas through a solution of calcium hydroxide. If the solution turns cloudy or milky the gas is a carbon dioxide.

3. a) Colour changes from green to black in first test tube. The second test tube turns milky.

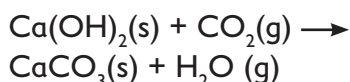
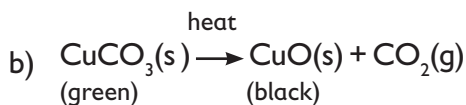

- c) No observable reaction. This is because Sodium carbonate does not decompose on heating since it is very stable.

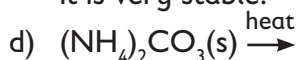

4. Carbon dioxide, carbon monoxide.
5. Yellow, white, red or pale orange, yellow.

6. Fossil fuels are used to provide energy required by many machines, their misuse leads to environmental degradation.

7. D

8. Boiling, distillation, addition of calcium hydroxide or sodium carbonate, use of ion exchange. Refer to learners book for equations.

9. A - Respiration

B - Gaseous exchange

C - Combustion

D - Photosynthesis

E - Photosynthesis

10.

- Reduce, reuse and recycle.
- Use less heat and air conditioning.
- Replace your light bulbs with energy saving bulbs.
- Drive less and drive smart.
- Buy energy-efficient products.
- Plant trees.

11. D

12. Combustion and respiration.

13. Sunlight, water, carbon dioxide.

14. (a) Carbon (b) photosynthesis.

(c) respiration (d) carbon monoxide

**b) Additional exercises for unit assessment (consolidation exercises)**

1. Choose the correct option to fill in the blank space in each sentence below.

a) \_\_\_\_\_ (Allotropy/ Crystals) is the existence of a chemical element in different physical forms. [Ans: Allotropy]

b) \_\_\_\_\_ (Crystalline/Amorphous) forms have regular shape and size. [Ans: Crystalline]

c) \_\_\_\_\_  
(Diamond/ Coal) is the crystalline form

d) In diamond ,each carbon atom is linked with \_\_\_\_\_ (four/ six) other carbon atoms. [Ans: four]

e) In graphite, each carbon atom is linked with \_\_\_\_\_ (three/six) other carbon atoms. [Ans: three]

f) \_\_\_\_\_ (Diamond /Graphite) is a good conductor of heat and electricity.  
[Ans: Diamond]

2. Develop a table on the differences between crystalline and amorphous forms of carbon. Answers

<b>Crystalline forms</b>	<b>Amorphous forms</b>
They have regular shape and size.	They do not have regular shape and size.
They have definite geometrical forms, sharp edges, and plane surfaces (these forms are referred to as Crystals.)	They do not have geometrical forms, sharp edges and plane surfaces.
They have fixed melting and boiling points.	They do not have fixed melting and boiling points.
The melting and boiling temperatures are high.	The melting and boiling temperatures are low.
Diamond, graphite and fullerene are crystalline forms of carbon.	Coal, charcoal and coke are amorphous forms of carbon.



3 a) What is wood gas?

During destructive distillation besides wood charcoal, bone charcoal or sugar charcoal, a mixture of gases are produced. These gases are carbon dioxide, carbon monoxide, methane and hydrogen gas. The mixture of these gases is combustible and is called wood gas.

(b) Write True or False.

i) Charcoal is black, soft and porous solid. [True]

ii) There are three varieties of coal. [False]

iii) Lamp Black is also called soot. [True]

iv) Coke produces smoke on burning. [true]

5. How does carbon dioxide affect lime water?

*Ans: Carbon dioxide gas reacts with limewater (calcium hydroxide) to form calcium carbonate solid which is insoluble. This causes the limewater to become cloudy/turbid/milk*

6. The following experiments were carried out to investigate physical and some chemical properties of carbon dioxide. Complete the table to indicate the expected observations.

Test for properties of carbon dioxide

Test	Observation
Smell	
Appearance	
Pass CO <sub>2</sub> through Lime water	
Pouring the gas over burning candle	
Universal indicator dropped into a jar as CO <sub>2</sub>	
Burning magnesium ribbon introduced into jar of CO <sub>2</sub>	

Answers to the above test for carbon dioxide

Test	Observation
Smell	Odourless
Appearance	colourless
Lime water	A white precipitate was formed in the solution and became clear as excess CO <sub>2</sub> was bubbled through it.
Burning candle	The burning candle was extinguished.
Universal indicator	The mixture became yellow.
Burning magnesium ribbon	The ribbon continue to burn with a crackling sound to form a white solid and black specks.

## Extended and remedial exercises

Remedial activities for slow learners	Extended activities for gifted and talented learners								
<ol style="list-style-type: none"> <li>1. Collecting, cleaning and arranging apparatus and reagents in the laboratory.</li> <li>2. Collect various materials and objects at home for experiments.</li> <li>3. Drawing diagrams from charts on their note books.</li> </ol>	<ol style="list-style-type: none"> <li>1. Do further research in textbooks or the Internet about carbon and its inorganic compounds. Write short notes then share with other class members.</li> <li>2. Set up experimental apparatus for practicals in the laboratory.</li> <li>3. Come up with a project and make a device for making dirty water clean and soft. Use locally available materials and make the item.</li> </ol>								
<p><b>Low order thinking (LOT) questions for slow learners</b></p>	<p><b>High order thinking (HOT) questions for gifted learners</b></p>								
<ol style="list-style-type: none"> <li>1. How would you differentiate hard and soft water?</li> <li>2. Name two non-crystalline forms of carbon.</li> <li>3. Give the properties of carbon dioxide.</li> <li>4. What is allotropy?</li> </ol>	<ol style="list-style-type: none"> <li>1. What causes global warming?</li> <li>2. Compare diamond and graphite as allotropes of carbon.</li> <li>3. Explain why carbon dioxide is not as poisonous as carbon monoxide to the body.</li> </ol>								
<p><b>Answers Low order thinking questions</b></p>	<p><b>Answers to high order thinking questions</b></p>								
<ol style="list-style-type: none"> <li>1. During washing soft water lathers easily while hard water takes longer time to form lather.</li> <li>2. Soot and charcoal.</li> <li>3. <ul style="list-style-type: none"> <li><input type="checkbox"/> Colourless gas</li> <li><input type="checkbox"/> Odourless at low concentration</li> <li><input type="checkbox"/> Denser than air</li> <li><input type="checkbox"/> Slightly soluble in water</li> </ul> </li> <li>4. The existence of two or more different physical forms of a chemical element.</li> </ol>	<ol style="list-style-type: none"> <li>1. Human activities and natural causes that increase greenhouse gases into the atmosphere.</li> <li>2. <table border="1" data-bbox="637 1148 1220 1487"> <thead> <tr> <th data-bbox="637 1148 892 1191">Diamond</th> <th data-bbox="899 1148 1220 1191">Graphite</th> </tr> </thead> <tbody> <tr> <td data-bbox="637 1191 892 1277">Does not conduct electricity.</td> <td data-bbox="899 1191 1220 1277">Conducts electricity due to delocalized electrons.</td> </tr> <tr> <td data-bbox="637 1277 892 1401">The hardest naturally occurring substance.</td> <td data-bbox="899 1277 1220 1401">It is soft and feels greasy.</td> </tr> <tr> <td data-bbox="637 1401 892 1487">Used to make cutting tools</td> <td data-bbox="899 1401 1220 1487">Used as electrodes, carbon raiser, lubricant</td> </tr> </tbody> </table> </li> <li>3. Carbon monoxide combines with haemoglobin in the body preventing uptake of oxygen in the blood hence could lead to suffocation thereafter death.</li> </ol>	Diamond	Graphite	Does not conduct electricity.	Conducts electricity due to delocalized electrons.	The hardest naturally occurring substance.	It is soft and feels greasy.	Used to make cutting tools	Used as electrodes, carbon raiser, lubricant
Diamond	Graphite								
Does not conduct electricity.	Conducts electricity due to delocalized electrons.								
The hardest naturally occurring substance.	It is soft and feels greasy.								
Used to make cutting tools	Used as electrodes, carbon raiser, lubricant								

*Refer to the Learner's book*

### Key Unit Competency

After studying this unit, learners should be able to relate the properties of nitrogen to its compounds and its uses and describe how some of its compounds are prepared and discuss related environmental issues.

### Learning objectives

At the end of this unit, the learners should have acquired the knowledge and understanding of physical and chemical properties of nitrogen and its uses. They should also explain the impact of nitrogen compounds on the environment.

**Table 2.1: Knowledge and understanding, skills and attitudes and values to be attained**

Knowledge and understanding	Skills	Attitude and values
<ul style="list-style-type: none"> <li><input type="checkbox"/> Explain physical and chemical properties of nitrogen and its uses.</li> <li><input type="checkbox"/> Explain the impact of nitrogen compounds on the environment.</li> <li><input type="checkbox"/> Explain the uses of nitric acid, ammonia and some nitrates.</li> </ul>	<ul style="list-style-type: none"> <li><input type="checkbox"/> Interpret the effect of ammonia solution on different cations.</li> <li><input type="checkbox"/> Develop observation skills during the experiments on addition of ammonia solution on different cations.</li> <li><input type="checkbox"/> Prepare and collect ammonia gas and nitric acid.</li> </ul>	<ul style="list-style-type: none"> <li><input type="checkbox"/> Protect natural resources.</li> <li><input type="checkbox"/> Develop self-confidence during presentation.</li> <li><input type="checkbox"/> Develop a culture of working in a team.</li> <li><input type="checkbox"/> Respect of procedure in all experiments.</li> <li><input type="checkbox"/> Appreciate the dangers cause by nitrogen compounds to the environment.</li> </ul>

## **Prerequisite of this unit**

Learners have learnt about nitrogen as an element in the periodic table in Senior one and two. They have also looked at some of its reactions with other substances. Notably the learner have looked at some compounds of nitrogen such as nitrogen dioxide and nitric acid. They are also aware that nitrogen forms the largest composition of air and can be isolated from it through physical means. Most fertilisers used in agriculture contain nitrogen.

Review all these reactions and properties of nitrogen as you prepare learners for this unit. This unit deals with properties of nitrogen and its compounds, how they are prepared and related environmental issues.

## **Links to other subjects**

During the lesson, bring to the attention of the learners the fact that this topic is linked to ecology in Biology in the study of natural resources. Nitrogen and its inorganic compounds form part of natural resources. This topic also is linked to Geography in the relationship between man and his environment.

## **Background information**

In unit 1, learners were introduced to the chemistry of carbon and its inorganic compounds. Let them understand that the chemistry of nitrogen and its inorganic compounds is approached the same way as that in unit 1. Thus the properties of nitrogen and its inorganic

compounds and the environment issues is discussed systematically. The test for cations using ammonia should be emphasised to enable learners acquire observation and data recording skills. The effect of nitrogen compounds such as nitrogen dioxide on the environment should be stressed and how nitrate fertilisers affect the soil pH.

## **Cross-cutting issues to be addressed**

### **1. Financial Education**

Sensitise learners on the need to use chemicals economically and handle apparatus carefully to avoid wastage or breakages which could otherwise have financial implications.

### **2. Inclusive education**

All learners should be encouraged to participate during lessons and practical experiments. Special education need learners should be given attention during the experiments. They should be assigned tasks they are capable of doing without strain.

### **3. Standardisation culture**

Emphasise to learners the need to use commodities approved by Rwanda Standards Board (RSB).

### **4. Gender education**

Both boys and girls should participate equally in all activities. Emphasise to learners the fact that anybody irrespective of their gender can pursue a career in Chemistry. Give examples

of role models who are successful in this career path.

## **5. Peace and values Education**

Encourage learners to work harmoniously with each other during class discussions and practicals.

## **6. Environment and sustainability education**

Bring to the attention of learners the fact that some compounds of nitrogen are dangerous to the environment. For example, gases like nitrogen dioxide hence they should avoid releasing such gases to the atmosphere as they may pollute the air and cause acid rains.

### **Generic competencies addressed**

#### **1. Research skills**

Guide learners on how to find information regarding various topics, on how to come up with summarised notes from a large body of text and on how to do Internet searches for the various content areas they are looking for.

#### **2. Co-operation and interpersonal management and life skills**

During group discussions and pair-work let learners engage one another by giving a chance for all to participate. Also, during group presentations, you can allow rotational presentations within the group members. Gifted learners should help in coming up with presentation content as slow learners contribute.

**Note:** You should allow slow learners to do presentations as well and correct them where they go wrong. Advise learners to appreciate the different abilities of their group members and accommodate each other's views.

#### **3. Communication in English**

Communication in English will be improved when learners freely participate in the discussions and presentations. Encourage all learners irrespective of their abilities to participate in group discussions, during presentations by asking questions and during question and answer sessions to either introduce or wrap up the lessons.

#### **4. Critical thinking**

This competence will be developed by learners as they answer the probing questions at the beginning of this unit and as they discuss the results of the various practical activities. Guide learners to discover for themselves inorganic compounds of nitrogen and their related environment issues. This competence will also come about as learners think about their findings in the activities and as they give out their suggestions.

#### **5. Lifelong learning skills**

Using internet and the other library resources such as journals, newspapers, cuttings and textbooks would enable learners to develop research skills in looking for important information and synthesising relevant information and knowledge.

## Key words used in this unit

- **Cations** – are positively charged ions.
- **Environment** – the surroundings or conditions in which a person, animal, or plant lives or operates.
- **Fractional distillation** – separation of a liquid mixture into fractions differing in boiling points by means of distillation, typically using a fractionating column.
- **Natural resources** – materials or substances such as minerals, forests, water, and fertile land that occur in nature and can be used for economic gain.
- **Haber process** – is a specific step by step procedure used in the manufacture of ammonia.
- **Hygroscopic** – the property of a substance tending to absorb moisture from the air.
- **Metahaemoglobin** – a stable oxidized form of haemoglobin that is unable to release oxygen to the tissues due to poisoning.
- **Ostwald process** – a chemical process for making nitric acid ( $\text{HNO}_3$ ).

## Guidance on the brain teaser

This topic involves nitrogen and its inorganic compounds. It introduces the learner to how nitrogen can be isolated from air and the properties and use of some of its inorganic compounds.

As a way of introducing these concepts, refer learners to the pictures in the learner's book. The pictures show products made from nitrogen and its inorganic compounds, or their uses. Allow learners in groups to discuss about the products. The groups should be constituted based on learners abilities and class size. Let them give answers to the probing questions associated with the pictures.

Answers to Fig. 2.1 include: A-nitrogen is pumped into fuel tanker to prevent explosion during transportation due to its inertness, B - storage and C - as a cleaning agent.

All these products or uses are derived from nitrogen and its organic compounds. You can then guide the learners to discover what they will learn in this topic. It also discusses environmental issues of compounds of nitrogen.

## Attention to special educational needs

Support for multi ability learning	Support for special needs learning
<ul style="list-style-type: none"><li><input type="checkbox"/> Gifted learners to assist the teacher in preparing chemicals for the practicals and to assist slow learners during the experimental procedures.</li><li><input type="checkbox"/> All learners to be given equal opportunity in leading group discussions and during presentations of group findings to the rest of the class.</li><li><input type="checkbox"/> Let learners work in harmony during the group activities.</li></ul>	<ul style="list-style-type: none"><li><input type="checkbox"/> Allocate gifted learners to help fellow learners with special needs.</li><li><input type="checkbox"/> Provide braille for blind learners and large print text to learners with seeing difficulties if available.</li><li><input type="checkbox"/> Also, arrange learners such that shortsighted ones are at the front and long-sighted ones are at the back. Spectacles can as well be provided if available for learners with seeing difficulties.</li></ul>

## List of lessons

Lesson Number	Lesson title	No. of periods
1	Industrial isolation of nitrogen	1
2	Laboratory preparation of nitrogen	2
3	Preparation, properties and uses of nitrogen dioxide	2
4	Preparation, properties and uses of ammonia	3
5	Preparation, properties and uses of nitric acid	2
6	Preparation, properties and uses of nitrates	2
7	Environmental issues with nitrogen dioxide and nitrate fertilisers	1
8	End of unit assesment test	2

## 2.1 Industrial isolation of nitrogen

*Refer to Learner's Book*

### Lesson 1: Industrial isolation of nitrogen (To be covered in one period)

#### Specific objectives

By the end of the lesson, learners should be able to describe the industrial

isolation of nitrogen.

#### Preparation for the lesson

1. This lesson will be taught in one period and will involve group work, research work and note taking. The learners should be organised in class in a way that suits discussion, research work and presentations.

2. Bring charts on the industrial isolation of nitrogen and text books for reference in class.
3. Research using text books and the internet, content related to industrial isolation of nitrogen.

**Note:** When placing learners in groups you should consider the different abilities of learners and the special needs of various individuals.

### Suggested teaching aids

- Charts on the industrial isolation of nitrogen.
- Video on industrial isolation of nitrogen where possible.
- Learner's book.

### Improvisation

Where there are no commercial charts, you may come up with your own charts drawn on manila papers.

### Pre-requisite to the lesson

Introduce the lesson by asking learners the components of air and how can they be separated and why the method is appropriate.

### Suggested teaching and learning activities

1. Ask probing questions to introduce the lesson. Such questions may include:
  - What is the electron arrangement of nitrogen (ans. 2:5)
  - To which group and period does nitrogen belong? (group (V), period 2)
2. Organise learners into groups of four for Activity 2.1 in the Learner's Book. This is basically a research activity. Provide learners with text books and charts. Ask them to find out how nitrogen is isolated industrially. Provide them with computers connected to the internet if available. Group work encourages team work and promotion of cooperation and interpersonal skills development, use of books and Internet impacts research skills.
3. Allow learners to have brief discussion on their findings then write summary notes. They will make presentations and correct them where necessary. Presentation and communication skills are promoted through presentation of learners' findings.
4. Use their presentation and content outlined in the Learner's Book to discuss industrial isolation of nitrogen as they take notes. This will develop learners' critical thinking and problem solving skills.
5. Summarise the lesson by bringing out the key points on how nitrogen is isolated from air.
6. End the lesson by instructing
  - Where does nitrogen occur naturally and to what percentage? (Ans. Air / atmosphere, 78%)



learners to attempt Self-evaluation Test 2.1.

## Synthesis

This lesson introduces learners to the process of isolating nitrogen from the atmosphere. The activities carried out during the lesson will help learners to develop research and communication skills and appreciate the importance of nitrogen in the atmosphere.

## Suggested lesson assessment

Assess whether the learning objectives of the lesson were achieved by asking questions such as:

1. Where does nitrogen occur in nature and to what percentage?

*(Ans. Atmosphere / Air, 78%.)*

2. Name the method used to industrially isolate nitrogen.

*(Ans. Fractional distillation.)*

3. Describe how nitrogen is industrially isolated from the atmosphere.

*(Ans. Refer to the Learner's Book)*

## Answers to Self-evaluation Test

### 2.1

*Refer to Learner's Book*

1. Air is not a compound but a mixture of gases i.e. oxygen, nitrogen, carbon dioxide among others.
2. a. To remove dust particles, water vapour and carbon dioxide.  
b. To remove rare gases.

- c. To separate the remaining gases according to their boiling points.

3. Refer to content on of the Learner's Book.

4. Nitrogen, 78%, fractional distillation

5. a. Y – It has a higher boiling point.

- b. Z – It has a lower boiling point.

- c. X – Its boiling point is between Y and Z.

- d. X- Argon Y – Oxygen Z- Nitrogen

## 2.2 Laboratory preparation of nitrogen

*Refer to Learner's Book*

### Lesson 2: Laboratory preparation of nitrogen (To be covered in two periods)

#### Specific objectives

By the end of the lesson, learners should be able to describe laboratory preparation of nitrogen.

#### Preparation for the lesson

1. This lesson will be taught in two periods and will involve practical experiments, group work, research work and note taking. The learners should be organised in class in a way that suits discussion, research work and presentations.
2. Bring charts on laboratory preparation of nitrogen and text books for references.
3. Collect the materials required for the experiments in advance and pretest the activity.

**Note:** When placing learners in groups you should consider the different abilities of learners and the special needs of various individuals.

### Suggested teaching aids

- Charts on the laboratory preparation of nitrogen.
- Video on laboratory preparation of nitrogen.
- Learners book.
- Reagents and apparatus.

### Improvisation

Where there are no commercial charts, you may come up with your own charts drawn on manila papers.

### Pre-requisite for this lesson

Let learners brainstorm about the gases found in the atmosphere. Take advantage of their mentioning nitrogen gas to introduce the concept here.

### Suggested teaching and learning activities

1. Organise learners into groups of four to carry out Activities 2.2 and 2.3 in the Learner's Book respectively. Group work promotes team work and encourages cooperation and interpersonnal skills development.
2. They will first do activity 2.2 then use the nitrogen obtained for activity 2.3.
3. Guide learners in setting up the apparatus and assist them during the experiments. Learners who are physically challenged can be assisted in setting up of apparatus. Those with visuals problems can be assisted by providing necessary tools such as large print text.
4. Instruct them to follow the procedure as laid out in the experiments.
5. After each experiment let them discuss their observations and findings after which they will do a presentation in class.
6. Build on their presentations to explain the laboratory preparation of nitrogen as outlined in the Learner's Book using equations. Also discuss the physical and chemical properties of nitrogen as outlined in the Learner's Book using relevant equations as they take notes. Presentation and communication skills, critical thinking skills will be developed here.
7. Let the learners search for the facts in the textbook and watch the video on the uses of nitrogen then discuss with them on their findings. Listening skills and research will be developed as a result.
8. Show learners the chart on the uses of nitrogen and let them itemize the uses.
9. Summarise the lesson by bringing out the key points on the properties and uses of nitrogen.

10. Emphasise the need for learners to avoid polluting the environment by releasing nitrogen compounds into the environment in general.

End the lesson by instructing learners to attempt questions in Self-evaluation Test 2.2.

### Synthesis

This lesson introduces learners to laboratory preparation of nitrogen, its physical and chemical properties and its uses. The activities carried out during the lesson will help learners to develop skills in observation, recording and team work.

### Suggested lesson assessment

Assess whether the learning objectives of the lesson are being achieved by asking questions such as:

1. State properties of nitrogen.

*(Ans: It is colourless, odourless, tasteless gas, sparingly soluble in water.)*

2. State two uses of nitrogen.

*(Ans: Used as a refrigerant for semen for artificial insemination, in food processing)*

### Answers to Self-evaluation Test

#### 2.2

Refer to Learner's Book

1. The amount of heat energy generated by a burning magnesium

ribbon is strong enough to break the triple bonds of nitrogen molecules. This makes nitrogen atoms available for the reaction.

2. It can be used for storing body tissues required to last for long periods of time i.e. can be used for preservation.
3. It is inert, lighter than air, almost insoluble in water
4. D

### 2.3 Preparation, properties and uses of nitrogen compounds

#### Lesson 3: Preparation, properties and uses of nitrogen dioxide gas (To be covered in 2 periods)

Refer to learner's book

#### Specific objectives

By the end of the lesson, learners should be able to:

- Explain how nitrogen dioxide is prepared in the laboratory.
- State the uses and properties of nitrogen dioxide.

#### Preparation for the lesson

1. This lesson will be taught in three periods and will involve experiments, group work, research work and note taking.

2. Bring charts on laboratory preparation of nitrogen dioxide and textbooks for reference.
3. Use locally available materials or the activities if necessary.

**Note:** When placing learners in groups you should consider the different abilities of learners and the special needs of various individuals.

### Suggested teaching aids

- Charts on the laboratory preparation of nitrogen dioxide.
- Video on laboratory preparation of nitrogen dioxide.
- Learner's book.
- Reagents and apparatus

### Improvisation

Where there are no commercial charts, you may come up with your own charts drawn on manila papers.

### Pre-requisite to the lesson

Remind learners of what they learnt in previous lesson about nitrogen then take advantage of their knowledge to introduce ammonia.

### Suggested teaching and learning activities

1. Organise learners into convenient groups according to availability of resources to carry out Activities 2.4 and 2.5 in the Learner's Book respectively. Group work encourages team work and promotes cooperating and interpersonal skills development.
2. They will first do activity 2.4 then use the nitrogen dioxide obtained for activity 2.5.
3. Guide learners in setting up the apparatus and assist them during the experiments. Let learners know that skills acquired will come in handy in careers such as quality control in industries.
4. Instruct them to follow the procedure as laid down in the experiments. Provide large print to learners with visual difficulties.
5. After each experiment let them discuss their observations and findings after which they should do a presentation in class.
6. Build on their presentation to explain the laboratory preparation of nitrogen dioxide as outlined in the Learner's Book using equations. Also discuss the physical and chemical properties of nitrogen dioxide as outlined in the learner's book using relevant chemical equations as they take notes.
7. Let learners look for the facts in textbooks and watch the video on the uses of nitrogen dioxide then discuss with them their findings. Fact findings from textbooks improve the research skills.
8. Show learners the chart on the uses of nitrogen dioxide and let them itemise the uses.

- Summarise the lesson by bringing out the key points on the properties and uses of nitrogen dioxide.
- End the lesson by instructing learners to attempt question in Self-evaluation Test 2.3 in the learners book.

### Synthesis

This lesson introduces learners to laboratory preparation of nitrogen dioxide, its physical and chemical properties and its uses. The activities carried out during the lesson will help learners develop respect of the procedures in all experiments.

### Suggested lesson assessment

Assess whether the learning objectives of the lesson are being achieved by asking questions such as:

- State properties of nitrogen dioxide  
(Ans: Red- brown gas, has irritating pungent smell, soluble in water.)
- State two uses of nitrogen dioxide  
(Ans:  
(a) Manufacture of nitric acid.  
(b) Used as rocket fuel.

### Answers to Self-evaluation Test 2.3

Refer to Learner's Book

- $2\text{NO}_2(\text{g}) + \text{H}_2\text{O}(\text{l}) \rightarrow \text{HNO}_2(\text{aq}) + \text{HNO}_3(\text{aq})$
- At room temperature, nitrogen dioxide molecule bonds are strong.

Introduction of burning magnesium ribbon breaks this bond making oxygen atoms available to support continued a reaction combustions.

- Manufacture of nitric acid.

### Lesson 4: Preparation, properties and uses of ammonia gas (To be covered in 3 periods)

Refer to Learner's Book

### Specific objectives

By the end of the lesson, learners should be able to:

- Explain how ammonia is prepared in the laboratory.
- State the uses and properties of ammonia.
- Describe the Haber process.

### Preparation for the lesson

- This lesson will be taught in three periods and will involve practical experiments, group work, research work and note taking. Organise learners in class in a way that suits discussion, research work and presentations.
- Bring charts on laboratory preparation of nitrogen dioxide and text books for reference in the laboratory.

**Note:** When placing learners in groups you should consider the different abilities of learners and the special needs of various individuals.

### **Suggested teaching aids**

- Charts on the laboratory preparation of ammonia and the Haber process.
- Video on laboratory preparation of ammonia and then Haber process.
- Learner's book.
- Reagents and apparatus.

### **Improvisation**

Where there are no commercial charts, you may come up with your own charts drawn on manila papers.

Use locally available materials where necessary.

### **Pre-requisite to the lesson**

Learners should know important nitrogen compounds for example ammonia. Therefore learning how to prepare it is important as well as its preparation.

### **Suggested teaching and learning activities**

1. Organise learners into convenient groups according to availability of resources to carry out Activities 2.6 and 2.7. Critical thinking and problem solving skills are developed as learners do the activity in the Learner's Book respectively. This promotes team spirit and encourages cooperation of interpersonal skills development.
2. They will first do activity 2.6 then use the ammonia gas obtained for activity 2.7.
3. Guide learners in setting up the apparatus and assist them during the experiments.
4. Instruct them to follow the procedure as laid down in the experiments. Help learners with learning difficulties to set up the apparatus. Also give large print text to learners with sight problems.
5. After each experiment let them discuss their observations and findings after which they will do a presentation in class. Communication, critical thinking and problem solving skills are developed through presentation and observations.
6. Build on their presentations to explain the laboratory preparation of ammonia gas as outlined in the Learner's Book using the provided equations. Also discuss the physical properties of ammonia gas as outlined in the Learner's Book using relevant chemical equations as they take notes.
7. Introduce chemical properties of ammonia by instructing learners to carry out activities 2.8, 2.9, 2.10 and 2.11 in the learner's book respectively.
8. After each experiment let them discuss their observations and findings after which they will do a presentation in class.
9. Build on their presentation to explain the chemical properties of ammonia gas as outlined in the Learner's Book using equations as they take notes.
10. Inform learners that ammonia is also

manufactured industrially through the Haber process.

11. Organise learners into groups and provide them with reference materials to do research on Haber process as suggested in the learner's book.
12. They should then do a presentation in class of their findings. Encourage learners to present as this will improve their communication skills.
13. Build on their presentation to explain the Haber process, use charts and diagrams to illustrate this as they take notes.
14. Let the learners search for the facts in textbooks and watch the video on the uses of ammonia then discuss with them their findings. Research and listening skills are developed through fact finding from books and internet.
15. Show learners the chart on the uses of ammonia and let them itemise the uses.
16. Summarise the lesson by bringing out the key points on the properties and uses of ammonia.
17. End the lesson by instructing learners to attempt questions in Self-evaluation Tests 2.4.

### Synthesis

This lesson will assist learners to understand and appreciate laboratory and industrial preparation of ammonia,

its physical and chemical properties and its uses. The activities carried out during the lesson will help learners to develop value and attitude in following procedures.

### Suggested lesson assessment

Assess whether the learning objectives of the lesson are being achieved by asking questions such as:

1. State properties of ammonia.  
*Ans. Colourless gas, has a pungent choking smell, very soluble in water.*
2. State two uses ammonia  
*Ans. Make fertilisers, manufacture of nitric acid, a cleaning solvent.*

### Answers to Self-evaluation Test

#### 2.4

Refer to Learner's book

1. Prepared in the fume chamber due to the choking pungent smell of the gas.
2. Ammonia reacts with the usual drying agents i.e. conc. sulphuric acid and calcium chloride but not calcium oxide.
3. React Ammonia gas with hydrogen chloride gas. Formation of white confirms the presence of Ammonia gas
4. Refer to Learner's Book, Fig 2.13.
5. Nitrogen and hydrogen, pressure of between 200-500 atmospheres and temperature of between 400° C – 500° C.

6. a) i. 3  
ii. 1  
b) Making fertilisers  
c) Fritz Haber  
d) Ammonia  
e) Iron catalyst  
f) They are recycled back to the converter.  
g) C

### **Lesson 5: Preparation, properties and uses of nitric acid (To be covered in 2 periods)**

*Refer to Learner's Book*

#### **Specific objectives**

By the end of the lesson, learners should be able to:

- Explain how nitric acid is prepared in the laboratory.
- State the uses and properties of nitric acid.

#### **Preparation for the lesson**

1. This lesson will be taught in three periods and will involve practical experiments, group work, research work and note taking. The learners should therefore be organised in class in a way that suits discussion, research work and presentations.
2. Bring charts on the laboratory preparation of nitric acid and textbooks for reference.

**Note:** When placing learners in groups you should consider the different abilities of learners and the special needs of various individuals.

#### **Suggested teaching aids**

- Charts on the laboratory preparation of nitric acid.
- Video on laboratory preparation of nitric acid.
- Learners' book.
- Reagents and apparatus.

#### **Improvisation**

Where there are no commercial charts, you may come up with your own charts drawn on manila papers.

#### **Pre-requisite to this lesson**

Remind learners what they learnt about uses of ammonia in previous lesson. Take advantage of the answers given to introduce manufacturing of nitric acid. Ask learners to brainstorm several properties of acids.

#### **Suggested teaching and learning activities**

1. Organise learners into convenient group size according to availability of resources to carry out Activities 2.12, 2.13 and 2.14 in the Learner's Book respectively. Group work encourages team work which promotes cooperation and interpersonal skills development.
2. They will first do activity 2.12 then use the ammonia gas obtained for activity 2.13.



3. Guide learners in setting up the apparatus and assist them during the experiments. Help learners with learning difficulties to set up apparatus.
4. Instruct them to follow the procedure as laid down in the experiments. Provide large print text for learners with visual problems.
5. After each experiment let learners discuss their observations and findings after which they should do a presentation in class. Discussion of observations and findings promote critical thinking while presentation help to develop communication skills among learners.
6. Build on their presentation to explain laboratory preparation of dilute nitric acid as outlined in the Learner's Book using equations. Communication and critical thinking will be developed through presentation of findings. Discuss also their findings of experiment 2.13 on the properties of dilute nitric acid as outlined in the learner's Book as they take notes.
7. Give learners further activity to do on industrial manufacture of nitric acid by Ostwald process. They should write a report which they should then present in class.
8. Build on their presentation to explain the Ostwald process as outlined in the Learner's Book using equations as they take notes.
9. Thereafter discuss the findings of experiment 2.14 as outlined in the learner's book as they take notes.
10. Let the learners search for the facts in text books and watch the video on the uses of nitric acid then discuss with them their findings. Fact finding in textbooks encourages development of research skills.
11. Show learners the chart on the uses of nitric acid and let them itemize the uses.
12. Summarise the lesson by bringing out the key points on the properties and uses of nitric acid.
13. End the lesson by instructing learners to attempt question in Self-evaluation Tests 2.5.

### Synthesis

This lesson is meant to help learners appreciate laboratory and industrial preparation of nitric acid, its physical and chemical properties and its uses. The activities carried out during the lesson will help learners to acquire knowledge and understanding and equip them with lifelong skills.

### Suggested lesson assessment

Assess whether the learning objectives of the lesson are being achieved by asking questions such as:

1. State the properties of nitric acid.

*Ans: powerful oxidizing agent, reacts with metals to produce hydrogen gas.*

2. State two uses of ammonia.

Ans. Making fertilisers, manufacture of explosives, dyes and plastics.

### Answers to Self-evaluation Test

#### 2.5

Refer to Learner's Book

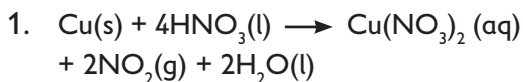

2. Used in the manufacture of fertilisers, explosives and plastics.

3. a) Vapours of nitric acid were evolved.

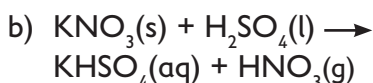

- c) It has no water of crystallisation.

- d) It is hygroscopic.

4. **Raw materials;** Ammonia air and water.

**Conditions;** Temperature of 850°C - 900°C, catalyst - platinum/rhodium.

5. D

6. A

7. Fountain

8. C

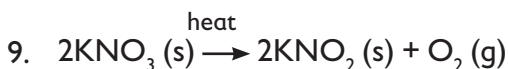

10. Potassium nitrate and sodium nitrate.

11. Deep blue solution forms which is copper nitrate salt. Red-brown fumes/vapour of nitrogen dioxide forms as well.

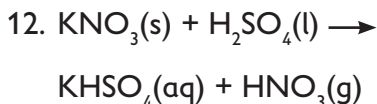

### Lesson 6: Preparation, properties and uses of nitrates (To be covered in 2 periods)

Refer to Learner's Book

#### Specific objectives

By the end of the lesson, learners should be able to:

- Explain how nitrates are prepared in the laboratory.
- Action of heat on nitrates.
- Test for nitrates.

#### Preparation for the lesson

1. This lesson will be taught in two periods and will involve carry out experiments, group work, research work and note taking. You should therefore organise the class accordingly.
2. Bring charts on the laboratory preparation of nitrates and textbooks for references.

**Note:** When placing learners in groups you should consider the different abilities of learners and the special needs of various individuals.

### **Suggested teaching aids**

- Charts on the laboratory preparation and test of nitrates.
- Video on laboratory preparation and test of nitrates.
- Learner's book.
- Reagents and apparatus.

### **Improvisation**

Where there are no commercial charts, you may come up with your own charts drawn on manila papers.

### **Prerequisite to this lesson**

Most learners know about nitrates used as fertilisers, point this out as you introduce the lesson. Besides this nitrates are used to make other substances e.g explosives. You can also link this lesson to what learners were taught about uses of nitric acids one of them being manufacture of fertilisers.

### **Suggested teaching and learning activities**

1. Organise learners into groups of five to carry out Activities 2.15 and 2.16 in the Learner's Book respectively. Group work activities encourage team work which promotes cooperation and interpersonal skills and acquisition of value education.
2. Guide learners in setting up the apparatus and assist them during the experiments. Provide large print text procedures to learners with seeing difficulties.

3. Instruct learners to follow the procedure as laid down in the experiments. Learners with learning disability can be helped out to set up apparatus during experiment.
4. After each experiment let them discuss their observations and findings after which they will do a presentation in class. Critical thinking is developed through discussion.
5. Build on their presentation to explain the laboratory preparation of nitrates as outlined in the learner's book using equations. Discuss also their findings of experiment 2.16 on the action of heat on nitrates as outlined in the Learner's Book as they take notes.
6. In their respective groups introduce Activity 2.17 in Learner's Book where learners will carry out testing for nitrates.
7. They should carry out the experiment as outlined and note down their observations. Allow learners to discuss and present their findings.
8. Build on their findings to explain the test for nitrates as outlined in the Learner's Book.
9. Let the learners search for the facts in the textbooks and watch videos on the uses of nitrates then discuss with them on their findings.
10. Show learners the chart on the uses

of nitrates and let them itemise the uses.

11. Summarise the lesson by bringing out the key points on the properties and uses of nitrates.

### Synthesis

This lesson equips learners with knowledge on laboratory preparation of nitrates, test for nitrates and its uses. The activities carried out during the lesson will help learners to appreciate the procedure followed during the manufacture of nitrates.

### Suggested lesson assessment

Assess whether the learning objectives of the lesson are being achieved by asking questions such as:

1. Which methods are used to prepare nitrates?

*Ans:*

- Neutralisation of dilute nitric acid by a base/alkali.
- Reaction between dilute nitric acid and a metal carbonate.
- Action of nitric acid on a metal.

2. State two uses of nitrates.

*Ans fertilisers, manufacture of gun powder and explosives.*

### Lesson 7: Environmental issues with nitrogen dioxide and nitrate fertilisers (To be covered in 1 period)

*Refer to Learner's Book*

### Specific objectives

By the end of the lesson, learners should

be able to:

- Appreciate the dangers caused by nitrogen compounds to the environment.
- Carry out research on protection of the environment and hence protect natural resources.

### Preparation for the lesson

1. This lesson will be taught in one period and will involve group work, research work and note taking. The learners should be organised in class in a way that suits discussion, research work and presentations.
2. Bring charts on the effects of nitrogen compounds on the environment and text books for reference.

**Note:** When placing learners in groups you should consider the different abilities of learners and the special needs of various individuals.

### Suggested teaching aids

- Charts on the effects of nitrogen compounds on the environment.
- Video on the effects of nitrogen compounds on the environment.
- Learner's book.

### Improvisation

Where there are no commercial charts, you may come up with your own charts drawn on manila papers.

### Prerequisite to this lesson

Environmental pollution is a factor that learners need to understand especially

when it involves dangerous chemicals. Let learners understand that nitrogen compounds pollute the environment and a way has to be found to curb this.

### **Suggested teaching and learning activities**

1. Organise learners into convenient groups to carry out research activity suggested in the Learner's Book. Group work encourages teamwork and promotes cooperation.
2. Instruct them to note down their findings which they will discuss and present to the rest of the class. Learners with learning difficulties can be helped by allocating other class members to assist them.
3. Build on their findings to explain the effects of nitrogen compounds on the environment as outlined in the Learner's Book as they take notes. Learners should be sensitised to take measures to prevent the occurrence rather than deal with the effects which could have financial implications.
4. Summarise the lesson by bringing out the key points on the effects of nitrogen compounds on the environment
5. End the topic by instructing learners to attempt Test your Competence 2.

This lesson creates awareness to the learners on the effects of nitrogen compounds on the environment. Learners should propose measures of curbing environmental pollution to their immediate environment.

### **Suggested lesson assessment**

Assess whether the learning objectives of the lesson are being achieved by asking questions such as:

How can we minimise the effects of nitrogen and its compounds to the environment?

Ans: Put scrubbers in exhaust pipes to filter nitrogen dioxide from industries and motor vehicles exhaust.

- Minimise the usage of fertilisers.

### **Summary of the unit**

This unit deals with nitrogen and its inorganic compounds. The learners are supposed to understand the physical and chemical properties of nitrogen its compounds and their uses.

Use the suggested activities and the teaching approaches in every lesson to enable learners understand nitrogen and its compounds and relate its properties to the various uses of nitrogen and associated compounds.

## **Synthesis**

## Additional information for the teacher

### A. General information about nitrogen

- Symbol: N
- Atomic Number: 7
- Atomic Weight: 14.0067
- Electron Configuration: 2:5
- Number of Protons/Electrons: 7
- Isotopes: N-13 (half-life 9.97 min.), N-14 (stable), N-15 (stable), N-16 (half-life 7.13 sec.)
- Crystal structure: Hexagonal
- Name Origin: from Greek: nitron (potassium nitrate,  $\text{KNO}_3$ ) + genes (former, producer)
- Classification: Non-metal

Nitrogen (N) is an important constituent of organic compounds (proteins) of the living organisms. DNA molecules forming the genetic code contain nitrogen. Nitrogen forms 78% of the earth atmosphere.

Nitrogen was discovered in 1772 by Daniel Rutherford (and independently by Carl Wilhelm). Molecules of gaseous nitrogen are normally diatomic ( $\text{N}_2$ ).

### B. Extraction (isolation) of nitrogen

#### 1. Cryogenic distillation of air

Cryogenic distillation is the most popular method of extraction of nitrogen. About 85% of nitrogen is produced by this method.

Cryogenic distillation utilises differences

in boiling points of the air components.

The air is cooled down to the state of boiling liquid. The vapours are condensed and reboiled for several times. Compositions of the liquid and the vapours are different. This technique permits separating of air to its constituents: nitrogen, oxygen and argon.

#### 2. Membrane separation of air

The method is based on differences in the permeability of the molecules composing air. Air flows through thousands of hollow-fiber polymer membranes installed in a tube. Oxygen molecules permeate through the membranes faster than molecules of nitrogen. Thus the air stream is separated into two parts, one of which is enriched with oxygen and another is enriched with nitrogen.

#### 3. Pressure swing adsorption

The method uses filters made of a material capable to adsorb molecules of oxygen. When air passes through the adsorbent oxygen is caught by the filter while nitrogen (together with argon) is collected at the outlet.

#### 4. Decomposition of ammonium nitrite

This method is used for laboratory preparation of nitrogen.

Heating ammonium nitrite causes its decomposition according to the reaction:

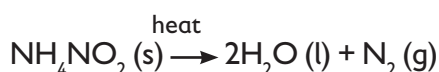

However the method is normally not used because when a small amount of  $\text{NH}_4\text{NO}_3$  remains it explodes.

### 5. *Decomposition of azides*

Very pure nitrogen may be prepared by decomposition of sodium azide ( $\text{NaN}_3$ ) at  $572^\circ\text{F}$  ( $300^\circ\text{C}$ ):  $2\text{NaN}_3 \rightarrow 2\text{Na} + 3\text{N}_2$

### C. *Nitrogen cycle*

- Nitrogen is an essential component of the living nature.
- Bacteria living in the soil are capable of converting the gaseous nitrogen into fertilising compounds (nitrogen fixation).
- Plants then use the fertiliser for their growth.
- Animals eating the plants use nitrogen contained by the plants for building proteins.
- Nitrogen of animals bodies is then converted by bacteria into gaseous form (denitrification).

### D. *The Haber process*

#### *The proportions of nitrogen and hydrogen*

The mixture of nitrogen and hydrogen going into the reactor is in the ratio of 1 volume of nitrogen to 3 volumes of hydrogen.

Avogadro's Law says that equal volumes of gases at the same temperature and pressure contain equal numbers of molecules. That means that the gases are going into the reactor in the ratio of

1 molecule of nitrogen to 3 of hydrogen. That is the proportion demanded by the equation.

In some reactions you might choose to use an excess of one of the reactants. You would do this if it is particularly important to use up as much as possible of the other reactant - if, for example, it was much more expensive. That does not apply in this case.

There is always a down-side to using anything other than the equation proportions. If you have an excess of one reactant there will be molecules passing through the reactor which can't possibly react because there isn't anything for them to react with. This wastes reactor space - particularly space on the surface of the catalyst.

#### *a. The temperature*

*Equilibrium considerations.* You need to shift the position of the equilibrium as far as possible to the right in order to produce the maximum possible amount of ammonia in the equilibrium mixture. The forward reaction (the production of ammonia) is exothermic.

According to Le Chatelier's Principle, this will be favoured if you lower the temperature. The system will respond by moving the position of equilibrium to counteract this - in other words by producing more heat. In order to get as much ammonia as possible in the equilibrium mixture, you need as low a temperature as possible. However,  $400 - 450^\circ\text{C}$  isn't a low temperature!

*Rate considerations:* The lower the temperature you use, the slower the reaction becomes. A manufacturer is trying to produce as much ammonia as possible per day. It makes no sense to try to achieve an equilibrium mixture which contains a very high proportion of ammonia if it takes several days for the reaction to reach that equilibrium.

You need the gases to reach equilibrium within the very short time that they will be in contact with the catalyst in the reactor.

The compromise: 400-450°C is a compromise temperature producing a reasonably high proportion of ammonia in the equilibrium mixture (even if it is only 15%), but in a very short time.

### **b. The pressure**

*Equilibrium considerations:* Notice that there are 4 molecules on the left-hand side of the equation, but only 2 on the right.

According to Le Chatelier's Principle, if you increase the pressure the system will respond by favouring the reaction which produces fewer molecules. That will cause the pressure to fall again. In order to get as much ammonia as possible in the equilibrium mixture, you need as high a pressure as possible. 200 atmospheres is a high pressure, but not amazingly high.

*Rate considerations:* Increasing the pressure brings the molecules closer together. In this particular instance, it

will increase their chances of hitting and sticking to the surface of the catalyst where they can react. The higher the pressure the better in terms of the rate of a gas reaction.

*Economic considerations:* Very high pressures are very expensive to produce on two counts. You have to build extremely strong pipes and containment vessels to withstand the very high pressure. That increases your capital costs when the plant is built.

High pressures maintenance is very costly. That means that the running costs of your plant are very high.

The compromise 200 atmospheres is chosen on economic grounds. If the pressure used is too high, the cost of generating it exceeds the price you can get for the extra ammonia produced.

### **c. The catalyst**

*Equilibrium considerations:* The catalyst has no effect whatsoever on the position of the equilibrium. Adding a catalyst doesn't produce any greater percentage of ammonia in the equilibrium mixture. Its only function is to speed up the reaction.

*Rate considerations:* In the absence of a catalyst the reaction is so slow that virtually no reaction happens in any sensible time. The catalyst ensures that the reaction is fast enough for a dynamic equilibrium to be set up within a very short time that the gases are actually in the reactor.



#### **d. Separating the ammonia**

When the gases leave the reactor they are hot and at a very high pressure. Ammonia is easily liquefied under pressure as long as it is not too hot, and so the temperature of the mixture is lowered enough for the ammonia to turn to a liquid state. The unreacted nitrogen and hydrogen remain as gases even under these high pressures, and can be recycled.

#### **E. The Ostwald process**

The Ostwald process was developed by Wilhelm Ostwald, after years of research work. It was created in 1902, patented in 1902, he then later was awarded the Nobel-peace prize for his work in 1909. This process was and still is a very important process because it is any easy way to produce nitric acid in only two steps. The process Wilhelm invented is still being used today because it is reliable and allows quicker production of nitric acid to meet its high demand.

In reference to LeChatelier's principle, since this reaction is exothermic... conditions that would favour the forward reaction and shift the equilibrium to the right would be decreasing the temperature, increase the concentration, and increasing the pressure and volume.

By decreasing the temperature, because this reaction is exothermic, the equilibrium will shift to the left away the added energy. So for favourable nitric acid production conditions, we

would want to decrease the temperature. By increasing the concentration, the equilibrium will shift away from the added product or reactant. Since we are constantly adding water and oxygen for this process as reactants, then increasing the concentration would create favorable conditions for the equilibrium. As for pressure and volume, the equilibrium would shift towards the side of the reaction with the less number of moles to help ease the pressure. So, taking step one's balanced equation as an example... the right side has less moles, so with increasing the pressure it would shift to the right. Which is favorable for the forward reaction.

Because of it's reaction when combined with organic compounds, most industrial probably don't use the most favorable conditions during the Ostwald process while creating because it will produce an unsafe concentration and corrosive tendencies within the nitric acid. This would be a safety hazard, which is actually why nitric acid is used in explosives.

The catalyst that is used for this reaction is a platinum gauze. It would be heated, however sometimes a substitute copper wire/rod can serve as a catalyst for this process.

#### **f. Nitrogen compounds and their effects to the environment**

Nitrogen compounds occur in excess in the air, water, soil and food, which unfavourably affects human's health,

causing a number of diseases. Toxic effect of nitrates and nitrites ought to be mentioned here. Nitrates and nitrites can be harmful, especially in infants and children, manifesting themselves by methemoglobinemia, anaemia and decreased content of vitamin A in the liver. Besides, nitrates and nitrites participate in the formation of strong nitrogen carcinogenic compounds, which may lead to stomach cancer. Due to big harmfulness of nitrogen compounds one should strive after lowering, minimizing their presence in the environment.

### End of unit assessment

This is divided into sections:

- Answer to test your competence 2.
- Additional exercises for the unit. (Consolidated exercises.)

#### a) Answers to Test your Competence 2

Refer to Learner's book

1. Nitrogen fertilisers used in crops planted near water bodies will be washed into the river hence polluting it.
2. Deep red-orange, strong harsh smell, pungent.
3. a) Blue litmus paper turns red because the gas is acidic.  
b)  $2\text{NO}_2(\text{g}) + \text{H}_2\text{O}(\text{l}) \rightarrow \text{HNO}_2(\text{aq}) + \text{HNO}_3(\text{aq})$
4. a) No heating indicated.  
b) Calcium oxide- drying of the gas

c) Upward delivery / downward displacement of air because ammonia is less dense than air.

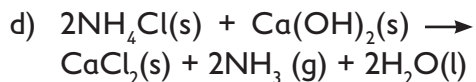

5. Haber process, Ostwald process.
6. Nitrogen and hydrogen ratio: 1 vol 3 vol at temperatures - about  $450^\circ\text{C}$ , high pressure - about 200 atmospheres.

7. a) The Ostwald process.

b) (i) Ammonia

(ii) Nitric acid

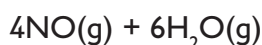
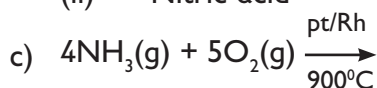

d) Hot nitric acid vapours attack rubber stoppers and tubings hence should be kept in glass bottles.

8. B

9. a) True

b) True

c) False

d) True

**(b) Additional unit assessment exercises (consolidation exercises)**

1. Write the formula of the complex ion formed when excess ammonia gas is passed through a solution containing  $Zn^{2+}$  ions.

Ans:  $[Zn(NH_3)_4]^{2+}$

2. Ammonia gas is prepared in the laboratory by the action of an alkali on an ammonium salt. Write the equation for the reaction that occurs when ammonium chloride and calcium hydroxide are used.

Ans:  $2NH_4Cl(s) + Ca(OH)_2(s) \rightarrow CaCl_2(aq) + 2H_2O(l) + 2NH_3(g)$

3. (a) Explain the importance of the high percentage of nitrogen in air.

Ans: Helps in plant growth fixed by nitrogen fixing bacteria and through lightning.

- (b) Why is nitrogen used for storage of semen in artificial insemination?

Ans: Because it has very low boiling point  $-196^\circ$ .

4. In an experiment, a few drops of concentrated nitric acid were added to aqueous iron (II) sulphate in a test tube. Excess ammonia solution was then added to the mixture. State the observations that were made when:

- (a) Concentrated nitric acid was added to aqueous iron (II) sulphate.

Ans: Pale-green solution turns into orange/brown solution.

- (b) Excess ammonia was added to the mixture.

Ans: Brown /red-brown precipitate insoluble in excess ammonia.

5. Dilute nitric acid is added to excess green solid. Effervescence occurs and a blue solution is formed. When excess ammonia solution is added to a sample of the solution, a deep-blue solution is formed.

- (a) Identify the anion and cation in the green solid.

Ans: Cation: Copper(II) ion ( $Cu^{2+}$ )  
Anion: carbonate ion ( $CO_3^{2-}$ )

- (b) Write an ionic equation for the reaction leading to formation of the deep-blue solution.

Ans:  $Cu^{2+} + 2OH^-(aq) \rightarrow Cu(OH)_2(s)$

$Cu(OH)_2(s) + 4NH_3(aq) \rightarrow [Cu(NH_3)_4]^{2+}(aq)$

6. The reaction between copper metal with 50% nitric acid in an open tube gives red brown fumes. Explain.

Ans: Reaction produces nitrogen dioxide gas which is brown in colour.

7. When a few drops of aqueous ammonia were added to a colourless solution X, a white precipitate was formed. On addition of more aqueous ammonia, the white precipitate dissolved to a colourless solution Q.

- (a) Name the white precipitate formed.

Ans: Zinc hydroxide ( $\text{Zn(OH)}_2$ )

(b) Write formula of the complex ion present in the colorless solution Q.

Ans:  $[\text{Zn}(\text{NH}_3)_4]^{2+}$

(c) Write an ionic equations for the formation of the white precipitate.

Ans:

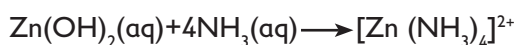
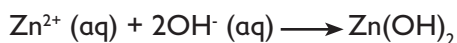

8. A factory uses nitric acid and ammonia as the only reactants for the production of a fertilizer. If a mass of 9600kg of fertilizer was produced,

a) Name the fertiliser manufactured.

Ans: Ammonium nitrate fertiliser

b) Calculate the mass of ammonia gas needed.

(N = 14, H = 1, O = 16)

Ans: The equation of the reaction:

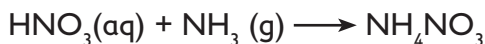

The reacting mole ratios are: 1:1  
Therefore,

17g of  $\text{NH}_3$  would produce 80g of

$\text{NH}_4\text{NO}_3$  fertiliser (from their formula masses) Thus 0.08 kg of fertilizer is produced by 0.017 kg of ammonia gas  
9600 kg of fertilizer is produced by x kg of ammonia gas

$$x = \frac{0.017\text{kg} \times 9600\text{kg of ammonia}}{0.08\text{kg}}$$

= 2040kg of ammonia

9. (a) State the conditions under which nitrogen reacts with hydrogen to form ammonia during Haber process.

Ans: Temperature of between  $350^\circ\text{C} - 500^\circ\text{C}$ .

-Presence of finely divided iron metal catalyst

-Pressure of between 200-1000 atmospheres.

(b) When dry ammonia gas is passed over hot copper (II) oxide, a shiny brown residue and colourless droplets are formed. Explain these two observations.

Ans: The brown residue is copper solid while colourless droplets is water.

## Extended and remedial exercises

Remedial activities for slow learners	Extended activities for gifted and talented learners
<ol style="list-style-type: none"><li>1. Collecting, cleaning and arranging apparatus and reagents in the laboratory.</li><li>2. Collect various materials and objects at home for experiments.</li><li>3. Drawing diagrams from charts on their notebooks.</li></ol>	<ol style="list-style-type: none"><li>1. Do further research in textbooks or from the internet about carbon and its inorganic compounds. Write short notes then share with other class members.</li><li>2. Set up experimental apparatus for practicals in the laboratory.</li><li>3. Come up with a project and make a device for preventing emission of dangerous nitrogen compounds. Use locally available materials and make the item.</li></ol>
<b>Low order thinking (LOT) questions for slow learners</b>	<b>High order thinking (HOT) questions for gifted learners</b>
<ol style="list-style-type: none"><li>1. Name two physical properties of nitrogen dioxide.</li><li>2. Complete the following reaction. <math display="block">\text{N}_2(\text{g}) + 3\text{H}_2(\text{g}) \longrightarrow</math></li><li>3. What is the confirmatory test for nitrates?</li></ol>	<ol style="list-style-type: none"><li>1. Air is not a compound but a mixture. Explain.</li><li>2. What are the effects of breathing in nitrogen dioxide?</li><li>3. During preparation of ammonia the flask is placed in a slanting position. Give reason for this.</li></ol>
<b>Answers Low order thinking questions</b>	<b>Answers to high order thinking questions</b>
<ol style="list-style-type: none"><li>1. Red-brown gas, has irritating pungent smell, soluble in water, denser than air.</li><li>2. <math display="block">\text{N}_2(\text{g}) + 3\text{H}_2(\text{g}) \longrightarrow 2\text{NH}_3(\text{g})</math></li><li>3. The brown ring test.</li></ol>	<ol style="list-style-type: none"><li>1. Air consist of gases that are not chemically combined.</li><li>2. Likelihood of respiratory problems as nitrogen dioxide inflames the lining of lungs hence reduced immunity.</li><li>3. To prevent drops of water vapour that condenses on the cooler parts of the flask from flowing back into the flask and cause it to crack.</li></ol>

# UNIT 3

## Sulphur and its inorganic compounds

*Refer to the Learner's book*

### Key Unit Competency

After studying this unit, the learner should be able to relate the properties of sulphur and its compound to its uses, show how its compounds are prepared and discuss related environmental issues.

### Learning objectives

Competency based curriculum embraces three categories of learning objectives namely, knowledge and understanding,

skills acquisition and attitude and values. At the end of this unit, learners should be able to demonstrate knowledge and understanding of properties of sulphur and its uses, how the compounds of sulphur are prepared and related environmental issues, develop skills in observation, preparation, testing and collection of compounds of sulphur and

**Table 3.1 Knowledge, skills and attitude to be attained**

Knowledge and understanding	Skills	Attitudes and values
<ul style="list-style-type: none"> <li><input type="checkbox"/> Explain occurrence, extraction, properties and uses of sulphur.</li> <li><input type="checkbox"/> Explain the impact of sulphur oxides on the environment.</li> <li><input type="checkbox"/> Describe the preparation of sulphuric acid (Contact process).</li> <li><input type="checkbox"/> State the properties and uses of sulphuric acid and sulphur compounds e.g. sulphur dioxide.</li> <li><input type="checkbox"/> Explain the properties of hydrogen sulphide.</li> </ul>	<ul style="list-style-type: none"> <li><input type="checkbox"/> Develop skills in observation in preparing sulphur dioxide gas and testing for the presence of sulphites and sulphides.</li> <li><input type="checkbox"/> Prepare, test and collect sulphur dioxide gas and other sulphur compounds.</li> <li><input type="checkbox"/> Prepare and test hydrogen sulphide.</li> <li><input type="checkbox"/> Test for the presence of sulphates and sulphites in given solutions.</li> </ul>	<ul style="list-style-type: none"> <li><input type="checkbox"/> Protect natural resources.</li> <li><input type="checkbox"/> Develop self-confidence in discussion and presentation of research findings.</li> <li><input type="checkbox"/> Develop a culture of working in a team during research and discussions.</li> <li><input type="checkbox"/> Respect of procedures during experiments.</li> </ul>

have the right attitude towards care of the environment.

### **Prerequisite to the unit**

Learners have learnt about sulphur as an element in the Periodic Table in Senior one and two. They have also studied some of its reactions with other substances.

The learners have looked at some compounds of sulphur such as sulphur dioxide and metal sulphates.

Review all these reactions and properties of sulphur as you prepare learners for this unit. Relate what the learners know about sulphur to its properties, compounds, preparation methods and related environmental issues covered in this unit.

### **Links to other subjects**

During the lesson, strive to bring to the awareness of learners the fact that this topic is related to ecology in Biology and how the compounds of sulphur affect the ecological balance of the environment. It is also related to Geography when looking at the relationship between human activities and the environment.

### **Background information**

The chemistry of sulphur and its inorganic compounds is very important in the manufacturing industry. How compounds of sulphur affect the environment is also important. The uses of sulphur in medicine, matches, vulcanisation of rubber etc., will help the learner to relate sulphur to real life applications. This topic will therefore

enable learners to know the link between learning chemistry of sulphur and its usefulness in our daily lives.

### **Cross-cutting issues to be addressed**

#### **1. Inclusive learning**

All learners should be encouraged to participate during lessons and experiments. Make arrangements to take care of learners with special needs. In particular learners with visual impairment should be placed in front of the classroom. Provide braille if available for the blind and large print text for those with poor eyesight.

Group physically challenged learners with the rest to assist them during movement and field trips and other practical activities. Furthermore, give these learners tasks they can manage comfortably during practicals.

#### **2. Gender education**

Both boys and girls should participate equally in all activities. Emphasise to learners that anybody irrespective of their gender can pursue any career in chemistry related field such as chemical engineering and analytical chemistry. Let them give examples of role models who are successful in their careers in this area locally.

#### **3. Financial education**

Emphasise the need to follow instructions and to handle apparatus carefully during practicals to minimise breakage and use reagents in specified quantities to minimise wastage.

All these have financial implications in terms of costs.

#### **4. Standardisation culture**

Emphasise the need to use chemicals and apparatus certified by the Rwanda Standards Board (RSB).

#### **5. Environment and sustainability education**

Bring to the attention of learners the fact that sulphur dioxide causes air pollution. Therefore, caution learners against release of this gas into the atmosphere.

#### **6. Peace and values education**

Emphasise to learners the importance of working in harmony with each other during group work and class activities and advise them to accommodate other people's views always.

#### **7. Health education**

Emphasise to learners that some inorganic sulphur compounds are dangerous to organisms' life.

### **Generic competencies**

#### **1. Research skills**

Guide learners on how to find information regarding various studies on sulphur, on how to come up with summarised notes from a large body of text.

#### **2. Communication in English**

Communication in English will be improved when learners freely participate

in the discussions and presentations. Encourage all learners irrespective of their abilities to participate in group discussions, during presentations by asking questions and during question and answer sessions to either introduce or wrap up the lessons.

#### **3. Cooperation and interpersonal management and life skills**

During group discussions and pair-work let learners engage one another by giving a chance for all to participate. Also, during group presentations, you can allow rotational presentations within the group members. Gifted learners should help in coming up with presentation content as slow learners contribute as well.

**Note:** You should allow slow learners to do presentations as well and correct them where they go wrong. Advise learners to appreciate the different abilities of their group members and accommodate each other's views.

#### **4. Critical thinking and problem solving skills**

This competence will be developed by learners as they answer the probing questions at the beginning of this unit and as they discuss the results of the various practical activities. Guide learners to discover for themselves compounds of sulphur. This competence will also come about as learners think about their findings in the activities and as they give out their suggestions.



## 5. Lifelong learning skills

Time management during class activities is important in instilling lifelong skills to the learners. Also skills acquired during practicals can help learners in their future careers.

### Key words in this unit and their meanings

- ❑ **Bleach** – to whiten by exposure to sunlight or a chemical process.
- ❑ **Claus process** – a gas desulphurising process for recovering element sulphur from gaseous hydrogen sulphide.
- ❑ **A dehydrating agent** – a substance that removes water from another substance.
- ❑ **Frasch process** – a method used to extract sulphur from its underground deposits.

- ❑ **Oleum** – a dense, corrosive liquid solution consisting of concentrated sulphuric acid with dissolved excess sulfur trioxide in it.
- ❑ **Pollution** – the presence in or introduction into the environment of a substance or thing that has harmful or poisonous effects.

### Guidance on the brain teaser

This unit is to equip learners with knowledge on sulphur and its inorganic compounds. Introduce the unit by learners discussing the pictures on of Learner's Book. The pictures show various products made from sulphur and its inorganic compounds. Allow learners in groups to discuss the products. The groups should be constituted based on learner abilities and class size. Let them give answers to

## Attention to special educational needs

Support for multi ability learning	Support for special needs learning
<ul style="list-style-type: none"><li>❑ Gifted learners to assist the teacher in setting up the apparatus during the experiments. Slow learners can be given tasks of recording experiment observations.</li><li>❑ All learners to be given equal opportunity during group discussions and presentations of group findings to the rest of the class.</li><li>❑ All learners to develop a culture of working together as a team during discussions and research.</li></ul>	<ul style="list-style-type: none"><li>❑ Provide large print texts and diagrams for learners with visual problems.</li><li>❑ Place special need learners into groups with the other learners.</li></ul>

the probing questions associated with the picture.

Guide the learners to discover what they will learn in this topic. Further,

emphasise the need for taking this topic seriously in the course of the lessons as it can lead to environmental awareness.

### List of lessons

Lesson Number	Lesson title	No. of periods
1	Occurrence and extraction of sulphur	2
2	Properties and uses of sulphur	1
3	Properties, preparation and uses of sulphur dioxide	4
4	Properties, preparation and uses of sulphuric acid	3
5	Preparations and test for sulphates and sulphites	2
6	Environmental issues related to sulphur oxides	1
7	End of unit assesment	2

## 3.1 Occurrence and extraction of sulphur

*Refer to Learner's Book*

### Lesson 1: Occurrence and extraction of sulphur (To be covered in two periods)

#### Specific objectives

By the end of the lesson, learners should be able to describe occurrence and extraction of sulphur.

#### Preparation for the lesson

1. This lesson will be taught in two periods and will involve, research work, conducting experiment and note taking. Learners can also be shown a video on extraction of sulphur.

2. Bring charts on the occurrence and extraction of sulphur and textbooks for reference.

#### Suggested teaching aids

- Charts on the occurrence and extraction of sulphur.
- Video on occurrence and extraction of sulphur.
- Learners book.

#### Improvisation

Where there are no commercial charts, you may come up with your own charts on extraction of sulphur drawn on manila papers.

#### Pre-requisite to the lesson

Introduce the lesson by asking learners

about the occurrence of other elements such as nitrogen and carbon. Borrowing from their answers, introduce the lesson.

### **Suggested teaching and learning activities**

1. Organise learners into groups to carry out the research activity suggested in learner's book.
2. They will discuss in their various groups the occurrence and extraction of sulphur. They will write a short report and present it to you for evaluation.
3. Build on their presentation to explain the occurrence and extraction of sulphur as outlined in the Learner's Book as they take notes. Group work encourages team work and promotes cooperation and interpersonal skills development.
4. Let learners watch videos on the occurrence and extraction of sulphur, use charts and diagrams too to illustrate this. Learners will develop listening skills through video watching.
5. Summarise the lesson by bringing out the key points on the occurrence and extraction of sulphur.

### **Synthesis**

Through the research activities learners should be able to explain occurrence, extraction and refining of sulphur.

### **Suggested lesson assessment**

Assess whether the learning objectives of the lesson were achieved by asking questions such as:

1. Where in nature is sulphur found?

*Ans: Volcanic regions and underground deposits*

2. How is sulphur extracted?

*Ans: Through the Frasch process for underground deposits or from crude oil gases*

## **3.2 Properties and uses of sulphur**

*Refer to Learner's Book*

### **Lesson 2: Properties and uses of sulphur (To be covered in one period)**

#### **Specific objectives**

By the end of the lesson, learners should be able to describe properties and uses of sulphur.

#### **Preparation for the lesson**

1. This lesson will be taught in two periods and will involve experiments. You should therefore conduct the lesson in the laboratory.
2. Bring charts on the properties and uses of sulphur and textbooks for reference.

**Note:** When placing learners in groups during practicals you should consider the different abilities of learners and the special needs of various individuals.

#### **Suggested teaching aids**

- Charts on the properties and uses of sulphur.
- Reagents and apparatus

### **Pre-requisite to the lesson**

Learners have already covered the properties of carbon and nitrogen. Remind them about these and let them understand that in this lesson, they will carry out experiments on the properties and uses of sulphur.

### **Suggested teaching and learning activities**

1. Organise learners into convenient groups according to availability of resources to carry out Activity 3.1 in the Learner's Book respectively. Group work encourages team work and promotes cooperation and interpersonal skills development.
2. Guide learners with difficulties in setting up the apparatus and assist them during the experiments as well.
3. Instruct them to follow the procedure as laid down in the experiments. Learners with visual problem can be given large print text.
4. After the experiment let them discuss their observations and findings after which they should do a presentation in class. Critical thinking, communication and presentation skills will be developed during these presentations and discussions on findings.
5. Build on their presentation to explain the properties of sulphur as outlined in the Learner's Book as they take notes.
6. Bring to the learners' attention the action of heat on sulphur as illustrated in table 3.1.
7. Let the learners search for the facts in text books and watch the video if available on the uses of sulphur then discuss with them their findings. Research skills will be developed through fact finding in the books and the internet searches.
8. Show learners the chart on the uses of sulphur and let them itemise the uses.
9. Summarise the lesson by bringing out the key points on the properties and uses of sulphur.
10. End the lesson by instructing learners to attempt question in Self-evaluation Test 3.1.

### **Synthesis**

This lesson is about investigating the physical and chemical properties and uses of sulphur. The activities carried out during the lesson should help learners to develop knowledge and attitude and lifelong skills in areas of experimentation.

### **Suggested lesson assessment**

Assess whether the learning objectives of the lesson are being achieved by asking questions such as:

Ans: Bright yellow solid at room temperature, soluble in organic solvents.

2. State two uses of sulphur.

Ans: Manufacture of sulphuric acid, matches, fireworks and gun powder.

### Answers to Self-evaluation Test

#### 3.1

Refer to Learner's book

- Hydrogen sulphide, zinc blende, iron pyrite, copper pyrite, galena.
- This is because of the existence of the rings which forms the structure of sulphur. Refer to table 3.1 in the Learner's Book for details.
- Burns with a blue flame.
  - There is formation of brown gas.
  - $S(s) + O_2(g) \rightarrow SO_2(g)$   
 $S(s) + 6HNO_3(aq) \rightarrow H_2SO_4(aq) + 6NO_2(g) + 2H_2O(l)$
- Manufacture of sulphuric acid.
  - Vulcanization of rubber.
  - Used as a fungicide.
  - In the production of various chemicals.

### 3.3 Inorganic compounds of sulphur and their properties

Refer to Learner's Book

### Lesson 3: Properties and uses of sulphur dioxide (To be covered in four periods)

#### Specific objectives

By the end of the lesson, learners should be able to describe properties and uses of sulphur dioxide.

#### Preparation for the lesson

- This lesson will be taught in four periods and will involve two practical sessions. It should therefore be conducted in the laboratory.
- Bring charts on properties and uses of sulphur dioxide and textbooks for reference.

**Note:** When placing learners in groups during practicals activities you should consider their different abilities and the special needs of the various individuals.

#### Suggested teaching aids

- Charts on the properties, tests and uses of sulphur dioxide.
- Video on properties tests and uses of sulphur.
- Learners book.
- Reagents and apparatus.

#### Improvisation

Where there are no commercial charts, you may come up with your own charts drawn on manila papers.

#### Pre-requisite to the unit

Remind learners the fact that sulphur just like nitrogen can form other compounds. Let them brainstorm on this.

### Suggested teaching and learning activities

1. Organise learners into convenient groups according to availability of resources to carry out Activities 3.2 and 3.3 in the learner's text book respectively.
2. They will first do activity 3.2 then use the sulphur dioxide obtained for activity 3.3.
3. Guide learners in setting up the apparatus and assist them during the experiments.
4. Instruct them to follow the procedure as laid out in the experiments.
5. After each experiment let them discuss their observations and findings after which they will do a presentation in class.
6. Build on their presentation to explain the laboratory preparation of sulphur dioxide as outlined in the Learner's Book using equations. Also discuss the physical and chemical properties of sulphur dioxide as outlined in the Learner's Book using relevant equations as they take notes.
7. Discuss with learners the laboratory test for sulphur dioxide as outlined in the Learner's Book.
8. Let the learners search for the facts in the text book and watch the video on the uses of sulphur dioxide then discuss with them on their findings.
9. Show learners the chart on the uses of sulphur dioxide and let them itemise the uses.
10. Summarise the lesson by bringing out the key points on the properties and uses of sulphur dioxide.
11. End the lesson by instructing learners to attempt question in Self-evaluation Tests 3.2.

### Synthesis

This lesson equips learners with knowledge on laboratory preparation of sulphur dioxide, its physical and chemical properties, its tests and uses. The activities carried out during the lesson will help learners to develop knowledge and attitude and also be equipped with lifelong skills.

### Suggested lesson assessment

Assess whether the learning objectives of the lesson are being achieved by asking questions such as:

1. State the physical properties of sulphur dioxide  
*Ans: It is colourless, has pungent choking smell, it is poisonous gas but soluble in water.*
2. State two uses of sulphur dioxide.  
*Ans: Used in the manufacture of sulphuric acid, preservative in jams and fruit juices.*

### Answers to Self-evaluation Test

#### 3.2

Refer to Learner's Book

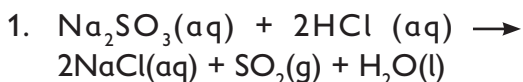

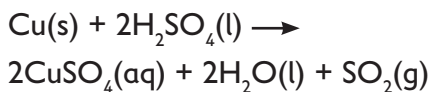

2. Sulphur dioxide is acidic oxide and exhibits bleaching properties like chlorine.
3.  $\text{SO}_2$  decolourises acidified potassium permanganate, changes acidified potassium dichromate (VI) from orange to green solution and iron chloride from yellow to green as well. So the suspect gas can be passed through the reagents mentioned above. For details Refer to Learner's Book activity 3.3.

### 3.4 Industrial preparation, properties and uses of sulphuric acid

*Refer to Learner's Book*

#### Lesson 4: Properties, preparation and uses of sulphuric acid (To be covered in three periods)

##### Specific objectives

By the end of the lesson, learners should be able to describe preparation, properties and uses of sulphuric acid.

##### Preparation for the lesson

1. This lesson will be taught in three periods and will involve experiments, conducted in the laboratories.
2. Bring charts on the properties and uses of sulphuric acid and text books for reference.

**Note:** When placing learners in groups during the practical activities you should

consider the different abilities of learners and the special needs of the various students.

##### Suggested teaching aids

- Charts on the preparation, properties and uses of sulphuric acid.
- Learners book
- Reagents and apparatus

##### Prerequisite to the lesson

Remind learners about the compounds of sulphur in the previous unit. Take advantage of their mention of sulphur dioxide and introduce sulphuric acid, its properties and uses.

##### Suggested teaching and learning activities

1. Begin the lesson by asking learners the importance of sulphuric acid. From their responses introduce the research activity suggested in the learners book.
2. They should carry out the activity in pairs, compile a report and present it in class
3. Build on their presentation to explain the stages of industrial preparation of sulphuric acid as outlined in the learner's book as they take notes. Use charts and chalkboard diagrams to illustrate this.
4. Organise learners into convenient groups according to availability of resources to carry out Activities 3.4 and 3.5 in the learner's text book respectively.

5. Guide learners in setting up the apparatus and assist them during the experiments.
6. Instruct them to follow the procedure as laid out in the experiments.
7. After each experiment let them discuss their observations and findings after which they will do a presentation in class.
8. Build on their presentations to explain the properties of concentrated sulphuric acid as outlined in the Learner's Book using equations. Also discuss the physical and chemical properties of dilute sulphuric acid as outlined in the Learner's Book using relevant equations as they take notes.
9. Let the learners search for the facts in text books and watch the video on the uses of sulphuric acid then discuss with them the findings. Research skills are developed through fact findings in textbooks.
10. Show learners the chart on the uses of nitrogen and let them itemise the uses.
11. Summarise the lesson by bringing out the key points on the properties and uses of dilute and concentrated sulphuric acid.
12. End the lesson by instructing learners to attempt question in Self-evaluation Tests 3.3 and 3.4.

## Synthesis

This lesson investigates properties of dilute and concentrated sulphuric acid, their physical and chemical properties and uses of sulphuric acid. The activities should enable learners to be equipped with knowledge in these areas.

### Suggested lesson assessment

Assess whether the learning objectives of the lesson are being achieved by asking questions such as:

1. State properties of sulphuric acid.  
*Ans: It is colourless and odourless gas, soluble in water.*
2. State two uses of sulphuric acid.  
*Ans: Manufacture of fertilisers, detergents, paints and dyes.*

### Answers to Self-evaluation Test

#### 3.3

Refer to Learner's Book

1. a) Contact process.  
b) Sulphur or its ore, air and water.  
c)  $2\text{ZnS}(s) + 3\text{O}_2(g) \rightarrow 2\text{ZnO}(s) + 2\text{SO}_2(g)$   
 $4\text{FeS}(s) + 7\text{O}_2(g) \rightarrow 2\text{Fe}_2\text{O}_3(s) + 4\text{SO}_2(g)$
2. a) Stage 1 – Production of sulphur dioxide.  
Stage 2 – Oxidation of sulphur dioxide to sulphur trioxide.  
Stage 3 – Production of oleum.  
Stage 4 – Dilution of oleum to form sulphuric acid.



b) 98%

3. The reaction is highly exothermic.

### Answers to Self-evaluation Test

#### 3.4

Refer to Learner's Book

1. Concentrated sulphuric acid readily absorbs water from the air or other substances.

2. Effervescence occurs. But the reaction quickly come to stop.

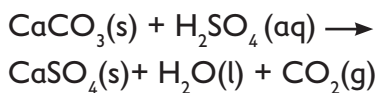

3. The reaction is highly exothermic forming harmful acid sprays



4. Manufacture of fertilisers, detergents, paints and dyes.

### Lesson 5: Preparation and tests for sulphates and sulphites (To be covered in two periods)

Refer to Learner's Book

#### Specific objectives

By the end of the lesson, learners should be able to describe laboratory preparation and test for sulphates and sulphites.

#### Preparation for the lesson

1. This lesson will be taught in two periods and will involve practical experiments on preparation and tests for sulphates and sulphites in the laboratory.
2. Bring charts on the preparation and test for sulphates and sulphites and

text books for reference.

**Note:** When grouping learners for experiments, consider their different abilities and the special needs of various students.

#### Suggested teaching aids

- Charts on the preparation and test for sulphates.
- Video on preparation and test for sulphates.
- Learner's book.
- Reagents and apparatus.

#### Pre-requisite to the lesson

From preparation of sulphuric acid and its properties in the previous lesson, let learners brainstorm about the type of salts that will be formed when sulphuric acid reacts with bases. The answer should be sulphates. Build on their answer to introduce this lesson.

#### Suggested teaching and learning activities

1. Organise learners into convenient groups according to availability of resources to carry out Activities 3.6 and 3.7 in the learner's text book respectively.
2. They will first do activity 3.6 then use the sulphates obtained for activity 3.7.
3. Guide learners in setting up the apparatus and assist them during the experiments.
4. Instruct them to follow the procedure as laid down in the experiments.

- After each experiment let them discuss their observations and findings after which they will do a presentation in class.
- Build on their presentation to explain the laboratory preparation of sulphates as outlined in the Learner's Book using equations. Also discuss the test for sulphite and sulphate ions as outlined in the Learner's Book using relevant equations as they take notes.
- Summarise the lesson by bringing out the key points on the preparation and testing for sulphates.

### Synthesis

This lesson is about laboratory preparation of sulphates and sulphites and their confirmatory tests. Learners should acquire skills in testing of unknown substances to confirm presence of sulphates and sulphities.

### Suggested lesson assessment

Assess whether the learning objectives of the lesson are being achieved by asking questions such as:

- State the various ways of preparing sulphates.
  - Ans: Neutralising dilute sulphuric acid with an alkali.*
  - Action of sulphuric acid on metals.*
  - Double decomposition.*
- How do you test for presence of

either sulphite and sulphate ions in solutions.

*Ans: By adding barium nitrate then dilute nitric acid. Sulphite will dissolve in acid while sulphate will not.*

### Lesson 6: Environmental issues related to sulphur dioxide (To be covered in 1 period)

*Refer to Learner's Book*

#### Specific objectives

By the end of the lesson, learners should be able to:

- Appreciate the dangers caused by sulphur compounds to the environment.
- Carry out research on protection of the environment and hence protect natural resources.

#### Preparation for the lesson

- This lesson will be taught in one period and will involve a visit to an environmental site that is polluted.
- Bring charts on effects of sulphur compounds on the environment and textbooks for reference.

#### Suggested teaching aids

- Charts on the effects of sulphur compounds on the environment.
- Video on the effects of sulphur compounds on the environment.
- A polluted environment.

#### Improvisation

Where there are no commercial charts, you may come up with your own charts drawn on manila papers. For example,

on effects of acid rain on iron sheets in buildings.

### **Pre-requisite to the lesson**

Sulphur also contributes to environmental pollution. Make learners aware of this fact. At the end of the lesson, they should come up with ways of reducing this kind of pollution.

### **Suggested teaching and learning activities**

1. Organise learners into convenient groups to carry out research activity suggested on the learner's book.
2. Instruct them to note down their findings which they should discuss and present to the rest of the class. Communication and presentation skills will be developed during presentations.
3. Build on their findings to explain the effects of sulphur compounds on the environment as outlined in the Learner's Book as they take notes. Advise them to avoid use of non-biodegradable plastics and fossil fuels to improve our environment sustainability.
4. Summarise the lesson by bringing out the key points on the effects of sulphur compounds on the environment.
5. End the sub-topic and topic by instructing learners to attempt Self-Evaluation Test 3.5 and Test your Competence 3.

### **Synthesis**

This lesson creates awareness in learners on the effects of sulphur compounds on the environment. Learners should know that environmental pollution due to sulphur compound is hazardous. They should come up with ways of preventing it or reducing such pollution.

### **Suggested lesson assessment**

Assess whether the learning objectives of the lesson were achieved by asking questions such as:

How can we minimise the effects of sulphur and its compounds to the environment?

*Ans: Put scrubber in exhaust pipes to filter sulphur dioxide from industries and motor vehicles.*

*Minimize the usage of sulphate fertilisers.*

### **Answers to Self-evaluation Test 3.5**

*Refer to Learner's Book*

1. Sulphur dioxide forms acid rain, which kills aquatic animals and destroys structure made of iron metal and cement.
2. To reduce environmental degradation hazards, and health risks associated with pollution.

### **Summary of the unit**

This unit deals with sulphur and its inorganic compounds. Use the suggested activities and learning approaches to let learners understand the occurrence, extraction, properties and uses of

sulphur and its compounds and their effects on the environment.

Learners should also develop skills in testing for the presence of sulphates and sulphites in given solutions. Through the lessons learners should develop attitudes and values geared towards preventing pollution of the environment. Further assess learners' understanding of the unit by giving them exercises and various activities.

### **Additional Information for the teacher**

#### **General information on sulphur**

- Atomic number, 16
- Atomic mass, 32.06 g mol<sup>-1</sup>
- Electronegativity, 2.5
- Density, g cm<sup>-3</sup> at 20 °C
- Melting point, 113 °C
- Boiling point, 445 °C
- Ionic radius, 0.184 (–2) nm ; 0.029 (+6)
- Isotopes, 5
- Electronic configuration, 2:8:6

Sulphur is a multivalent non-metal, abundant, tasteless and odourless. In its native form sulphur is a yellow crystalline solid. In nature it occurs as the pure element or as sulphide and sulphate minerals. Although sulphur is infamous for its smell, frequently compared to rotten eggs, that odour is actually characteristic of hydrogen sulphide (H<sub>2</sub>S). The crystallography of sulphur is complex. Depending on the specific conditions, sulphur allotropes

form several distinct crystal structures.

### **Applications**

The major derivative of sulphur is sulphuric acid (H<sub>2</sub>SO<sub>4</sub>), one of the most important compounds used as an industrial raw material.

Sulphur is a raw material for making sulphur acid also used in batteries, detergents, fungicides, manufacture of fertilisers, gun powder, matches and fireworks. Other applications are making corrosion-resistant concrete which has great strength and is frost resistant, for solvents and in a host of other products of the chemical and pharmaceutical industries.

### **Occurrence of sulphur in the environment**

Life on Earth may have been possible because of sulphur. Conditions in the early seas were such that simple chemical reactions could have generated the range of amino acids that are the building blocks of life.

Sulphur occurs naturally near volcanoes. Native sulphur occurs naturally as massive deposits in Texas and Louisiana in the USA. Many sulphide minerals are known: pyrite and marcasite are iron sulphide; stibnite is antimony sulphide; galena is lead sulphide; cinnabar is mercury sulphide and sphalerite is zinc sulphide. Other, more important, sulphide ores are chalcopyrite, bornite, penlandite, millerite and molybdenite.

The chief source of sulphur for industry is the hydrogen sulphide of natural gas, which Canada is the main producer.

## Health effects of sulphur

All living things need sulphur. It is especially important for humans because it is part of the amino acid methionine, which is an absolute dietary requirement for us. The amino acid, cysteine, also contains sulphur. The average person takes in around 900 mg of sulphur per day, mainly in the form of protein.

Elemental sulphur is not toxic, but many simple sulphur derivatives are, such as sulphur dioxide (SO<sub>2</sub>) and hydrogen sulphide are poisonous.

Sulphur can be found commonly in nature as sulphides. During several processes sulphur bonds are added to the environment that are damaging to animals, as well as humans. These damaging sulphur bonds are also shaped in nature during various reactions, mostly when substances that are not naturally present have already been added. They are unwanted because of their unpleasant smells and are often highly toxic.

Globally sulphuric acid can have the following effects on human health:

- Neurological effects and behavioural changes.
- Disturbance of blood circulation.
- Heart damage.

- Effects on eyes and eyesight.
- Reproductive failure.
- Damage to immune systems.
- Stomach and gastrointestinal disorder.
- Damage to liver and kidney functions.
- Hearing defects.
- Disturbance of the hormonal metabolism.
- Dermatological effects.
- Suffocation and lung embolism.

## Effects of sulphur on the environment

Sulphur can be found in the air in many different forms. It can cause irritations of the eyes and the throat with animals, when the uptake takes place through inhalation of sulphur in the gaseous phase. Sulphur is applied in industries widely and emitted to air, due to the limited possibilities of destruction of the sulphur bonds that are applied.

The damaging effects of sulphur with animals are mostly brain damage, through malfunctioning of the hypothalamus, and damage to the nervous system.

Laboratory tests with test animals have indicated that sulphur can cause serious vascular damage in veins of the brains, the heart and the kidneys. These tests have also indicated that certain forms of sulphur can cause foetal damage and

congenital effects. Mothers can even carry sulphur poisoning over to their children through mother milk. Finally, sulfur can damage the internal enzyme systems of animals.

### End of unit assessment

This is presented in two sections:

- Answers to Test your Competence 3
- Additional end of unit exercises (consolidation activities)

#### a) Answers to Test your Competence 3

Refer to Learner's Book

1. Frasch, Contact
2. a) Carefully add the concentrated acid to water.  
b) When reverse happens i.e. water is added to the acid the reaction produces heat causing the acid, to splatter forming dangerous acid sprays all around.
3. a) A - Hot compressed air  
B - Super - heated water  
C - Molten sulphur  
b) B provides Super-heated water that melts sulphur, while pipe A injects hot compressed air that forces sulphur out as froth.
4. B
5. a) False  
b) False  
c) True  
d) False
6. Vanadium(V) oxide ( $V_2O_5$ )
7. (a) A bright - blue flame.  
(b)  $S(s) + O_2(g) \xrightarrow{\text{Heat}} SO_2(g)$   
(c) Environmental pollution as a result of release of  $SO_2$  to the atmosphere to form acid rain/ human health risk
8. (a) (i) Any of the sulphur ores such as: Zinc blend ( $ZnS$ ), Iron pyrites( $FeS_2$ ), copper pyrites ( $CuFeS_2$ ) or galena ( $PbS$ ).  
(ii) Sulphur trioxide ( $SO_3$ )  
(iii) Conc. sulphuric acid  
(b)  $V_2O_5$ ,  $450^\circ C - 500^\circ C$   
(c) - Usage of sulphur – free fuels.  
- Recycling of unreacted gases.  
- Use of chimney scrubbers.
9. Check for correct argument on the effects of sulphur on the environment and solutions provided. Refer to Learner's Book for more information.
10. a)  $H_2S$   
b) Health problems and pollution.
11. a) It burns with a blue flame producing white fumes.  
b)  $S(s) + O_2(g) \xrightarrow{\text{Heat}} SO_2(g)$   
c) Sulphurous acid  
 $SO_2(g) + H_2O(l) \rightarrow H_2SO_3(aq)$   
d) It turns red.

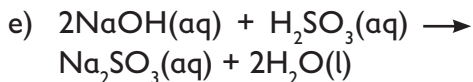

12. a) Using scrubbers in industries, minimise use of aerosols.
- b) Due to increased industrialisation the problem is increasing hence needs to be checked.

- c) Industrialisation and use of fossil fuels globally. These increases release of harmful gases such as  $\text{SO}_2$  into the atmosphere.
- d) Global efforts should be used to fight pollution.

### b) Additional exercises for assessment (consolidation exercise)

1. Name the two main allotropes of sulphur.

Ans:

*Rhombic and Monoclinic sulphur*

2. Differentiate between the bleaching action of chlorine and sulphur dioxide gas.

Ans: The bleaching behaviour of sulphur dioxide is actually due to its reducing properties. For example, in the presence of water, it bleaches sponges, dyes and straw hats. The sulphurous acid formed between sulphur dioxide and water takes up oxygen from the colouring matter (i.e. sponges, dyes and straw hats), converting them to colourless (reduced) compounds. See student book.

The reduced compounds may be re-converted to the original compounds through oxidation process after sometime by exposing them to the oxygen of the air. This is why bleached straw hats gradually becomes yellow with time (when exposed to air).

**Note:** bleaching action by  $\text{SO}_2$  is a reduction process.

The bleaching action of chlorine is a addition process. It occurs according to the following equation.

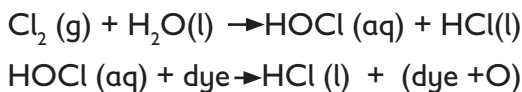

3. Is concentrated sulphuric acid a weak acid or a strong acid? Explain your answer.

Ans: concentrated sulphuric acid  $\text{H}_2\text{SO}_4$  is a strong acid because it completely dissociates in water.

4. In the manufacture of sulphuric acid, sulphur dioxide is oxidised to sulphur trioxide gas.

a) Name the catalyst used.

Ans: Vanadium pentoxide ( $\text{V}_2\text{O}_5$ ) - most preferred / platinum

b) Write the equation representing the conversion of sulphur dioxide to sulphur trioxide.

Ans:

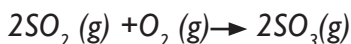

c) Explain using equations how dilute sulphuric acid is finally obtained from sulphur trioxide

Ans:

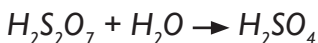

5. When hydrogen sulphide gas was passed through a solution of iron (III) chloride, the following observations were made:

(i) The colour of the solution changed from reddish-brown to green

(ii) A yellow solid was deposited.

Explain the observation.

Ans: Hydrogen sulphide is a reducing agent, it reduces iron (III) to iron(II) and a yellow deposit of sulphur.

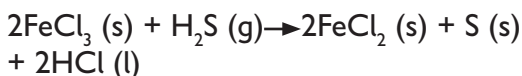

6. In the manufacture of sulphuric acid by Contact process, sulphur dioxide is made to react with air to form sulphur trioxide as shown in the following equation:



a) State and explain the effect of the following changes on the yield of sulphur trioxide.

(i) Increasing the pressure

Increasing the pressure increases the yield of sulphur trioxide since the forward reaction proceeds with decrease in number of moles.

(ii) Using a catalyst

Catalyst increases the rate at which the equilibrium is attained but has no effect on the yield of sulphur trioxide.

7. In an attempt to prepare carbon dioxide gas, dilute sulphuric acid was reacted with barium carbonate. The yield of carbon dioxide was found to be negligible. Explain.

Ans: The equation of the reaction is:

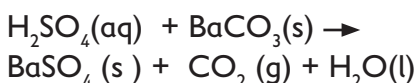

The barium sulphate which is insoluble quickly forms on the carbonate surface, thereby rendering it inaccessible to sulphuric acid preventing any further reaction and production of carbon dioxide.

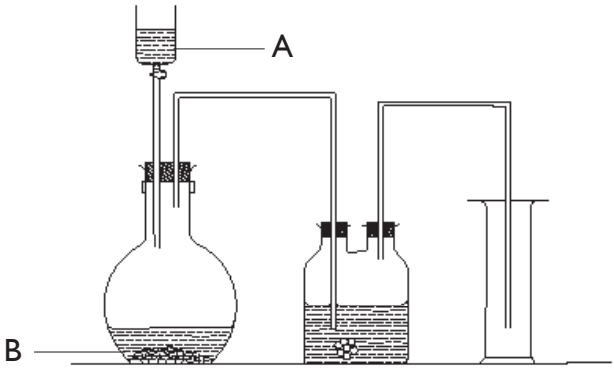

## Extended and remedial activities

Remedial activities for slow learners	Extended activities for gifted and talented learners
<p>1. Assist them to draw charts on the Frasch process and the Contact process. Use also audio and visual materials. This will enable them visualize the processes better.</p> <p>2. Provide models if available of the Frasch process and the Contact process.</p> <p>3. Give them extra assessment test such as:</p> <p>(a) State any three physical properties of sulphur oxide</p> <p>(b) Give any two uses of sulphur oxide</p> <p><i>Answers</i></p> <p>(a) -Colourless gas -Gas with characteristic irritating smell -Poisonous gas.</p> <p>(b) -Bleaching agent -An intermediate in the production of sulphuric acid.</p>	<p>Guide them to do an experiment on the changes that take place in sulphur when heated at different temperatures.</p> <p>Extra access questions</p>  <p>I. Study the above diagram representing the preparation and collection of sulphur dioxide in the laboratory.</p> <p>(a) Identify A and B.</p> <p>(b) (i) Write equation for the reaction in the flask.</p> <p>a. A - Hydrochloric acid B - Carbonate</p> <p>b. <math>\text{CO}_3^{2-}(\text{s}) + 2\text{HCl}(\text{aq}) \rightarrow 2\text{Cl}^-(\text{aq}) + \text{H}_2\text{O}(\text{l}) + \text{CO}_2(\text{g})</math></p>

*Refer to Learner's Book***Key unit competency**

After studying this unit, the learner should be able to relate the properties of chlorine and its inorganic compounds to their uses, describe how its compounds are prepared and discuss the related environmental issues.

**Learning objectives**

At the end of this unit, learners should be able to demonstrate knowledge and

understanding of physical and chemical properties of chlorine and its compounds and explain the preparation of chlorine, they should have acquired skills in observation, research, preparation and testing of chlorine and its compounds. They should have a positive attitude towards appreciating uses of chlorine and its inorganic compounds and their environmental impacts.

**Table 4.1 knowledge, skills and attitude to be attained**

<b>Knowledge and understanding</b>	<b>Skills</b>	<b>Attitudes and values</b>
<ul style="list-style-type: none"> <li><input type="checkbox"/> Describe the physical and chemical properties of chlorine and its compounds.</li> <li><input type="checkbox"/> Explain the preparation of chlorine gas.</li> <li><input type="checkbox"/> Explain the toxicity of chlorine and its impact on the environment.</li> </ul>	<ul style="list-style-type: none"> <li><input type="checkbox"/> Observe the colour formed in preparation of chlorine.</li> <li><input type="checkbox"/> Research skill in the protection of the environment.</li> <li><input type="checkbox"/> Prepare chlorine in the laboratory.</li> <li><input type="checkbox"/> Test chlorine properties in the laboratory.</li> <li><input type="checkbox"/> Prepare hydrogen chloride in the laboratory.</li> <li><input type="checkbox"/> Test for the presence of chlorides and other halides in solution.</li> </ul>	<ul style="list-style-type: none"> <li><input type="checkbox"/> Protect natural resources.</li> <li><input type="checkbox"/> Develop self-confidence in presentation of researched work and discussion in groups.</li> <li><input type="checkbox"/> Develop the culture of working in groups.</li> <li><input type="checkbox"/> Appreciate the impact of CFCs on the environment.</li> <li><input type="checkbox"/> Respect of procedures in experiment.</li> </ul>

## **Pre-requisite to the unit**

Learners have learnt about chlorine as an element in the Periodic Table. They have looked at some of its reactions with other substances. They have also learnt about compounds of chlorine such as hydrochloric acid and hydrogen chloride gas.

Review all these reactions of chlorine as you prepare learners for this unit.

## **Links to other subjects**

During the lesson, strive to bring to the attention of learners the fact that this topic is related to Geography regarding content on man and his or her environment. It is also linked to Biology under the topic of digestion whereby hydrochloric acid is dissolved to play an important role in the stomach.

## **Background information**

The chemistry of chlorine and its inorganic compounds is important in understanding how these compounds affect the environment. The effect of CFC on the environment should be discussed thoroughly. Let the learners understand that aerosol sprays introduce CFC in the environment. The importance of chlorine compounds in the chemical industry should also be explained.

## **Cross-cutting issues to be addressed**

### **1. Inclusive learning**

Learners should be encouraged to participate during lessons and practical

experiment. Make arrangement to take care of learners with special needs. In particular learners with visual impairment should be placed in front of the classroom. Provide braille if available for blind learners and for learners with poor eyesight provide large print text if available.

Physically challenged learners be assigned to other learners to assist them during movement and field trips and other practical activities. Also, give these learners tasks they can manage comfortably during practical activities.

### **2. Gender education**

Both boys and girls should participate equally in all activities. Emphasise to learners that anybody irrespective of their gender can pursue a career in any field. Give examples of role models who are successful in Chemistry related career locally.

### **3. Financial education**

Emphasise the need to follow instructions, handle apparatus carefully to minimise breakage and use reagents in specified quantities to minimise wastage. All these have financial implications in terms of cost.

### **4. Standardisation culture**

Emphasise the need to use chemicals and apparatus certified by the Rwanda Standards Board (RSB).

## 5. Environment and sustainability education

Bring to the attention of learners the fact that compounds of chlorine such as chlorofluoro carbons (CFCs) are linked to global warming hence need to be handled with care.

## 6. Peace and values education

Emphasise to learners the importance of working harmoniously with each other during group work and class activities and the need to accommodate each others views.

### Generic competencies

#### 1. Research skills

Guide learners on how to find information regarding various topics, on how to come up with summarised notes from a large body of text and on how to do internet searches for the various content areas they are looking for.

#### 2. Communication in English

Communication in English will be improved when learners freely participate in the discussions and presentations. Encourage all learners irrespective of their abilities to participate in group discussions, during presentations by asking questions and during question and answer sessions to either introduce or wrap up the lessons.

#### 3. Cooperation and interpersonal management and life skills

During group discussions and pair-work

let learners engage one another by giving a chance for all to participate. Also, during group presentations, you can allow rotational presentations within the group members. Gifted learners should help in coming up with presentation content as slow learners contribute.

**Note:** You should allow slow learners to do presentations as well and correct them where they go wrong. Advise learners to appreciate the different abilities of their group members and accommodate each other's views.

#### 4. Critical thinking and problem solving skills

This competence will be developed by learners as they answer the probing questions at the beginning of this unit and as they discuss the results of the various practical activities. Guide learners to discover for themselves inorganic compounds of chlorine. This competence will also come about as learners review their findings in the activities carried out and as they give out their suggestions.

#### 5. Lifelong learning skills

Good environmental management and realising the importance of natural resources builds the economy of a country.

#### Key words in this unit and their meanings

- **Aqua regia** - is a mixture of nitric acid and hydrochloric acid, optimally

- ❑ **Chlorofluorocarbon (CFC)** - an organic compound that contains only carbon, chlorine, and fluorine.
- ❑ **Condiment** - a substance such as salt or ketchup that is used to add flavour to food.
- ❑ **Dichlorodiphenyltrichloroethane (DDT)**-was a commonly-used pesticide for insect control. It was banned in many countries due to its side effects.
- ❑ **Dioxins** - are a group of chemically-related compounds that are persistent environmental pollutants.
- ❑ **Halogens** – a group of five non-metallic elements found in group 7 of the periodic table. The term “halogen” means “salt-former” and compounds containing halogens are called “salts.
- ❑ **Polyvinyl butyral (PVB)** – a resin mostly used for applications that require strong binding, optical clarity, adhesion to many surfaces, toughness and flexibility.
- ❑ **Polyvinyl chloride (PVC)** – the -most widely produced synthetic plastic polymer.

### **Guidance on the Brain teaser**

In this topic, you will teach about chlorine and its inorganic compounds. As a way of introducing these concepts, refer learners to the pictures on of the Learner’s Book. The pictures show various products made from chlorine and its inorganic compounds. Allow learners in groups to discuss the products. The groups should be constituted based on learner abilities and class size. Let them give answers to the probing questions associated with the picture.

Learning will develop various skills for example research skills as they carry out research activities, observation and recording of results, preparation and testing on the presence of chlorides. All these skills are important during experimental procedures. Guide the learners to discover what they will learn in this topic. Further, emphasise the need for taking this topic seriously in the course of the lessons as it can lead to environmental awareness.

## Attention to special educational needs

Support for multi-ability learning	Support for special needs learning
<ul style="list-style-type: none"> <li><input type="checkbox"/> Assign gifted learners the task of leading research and experiment activities. Let them guide and assist the below average learners.</li> <li><input type="checkbox"/> Give below average learners remedial activities and exercises to enable them catch up with the gifted learners.</li> <li><input type="checkbox"/> Let all learners work as a team during activities.</li> </ul>	<ul style="list-style-type: none"> <li><input type="checkbox"/> Provide special needs learners with materials they can use and interact with without difficulty.</li> <li><input type="checkbox"/> Assign special need learners with the other learners for assistance where necessary during activities and class work.</li> </ul>

### List of lessons

Lesson Number	Lesson title	No. of periods
1	Preparation and test for chlorine	2
2	Chemical properties and uses of chlorine	4
3	Preparation and properties of compounds of chlorine	4
5	Tests for chlorides and halides in solution	2
6	Environmental issues related to chlorine and its compounds	1
7	End of unit assesment test	2

## 4.1 Preparation and test for chlorine

*Refer to Learner's Book*

### Lesson 1: Preparation and test for chlorine (To be covered in two periods)

#### Specific objectives

By the end of the lesson, learners should be able to prepare and test for chlorine.

#### Preparation for the lesson

1. This lesson will be taught in two

periods and a practical session in the laboratory.

2. Bring charts on preparation of chlorine and textbooks for reference.

**Note:** When grouping learners for the practical sessions, you should consider the different abilities of learners and the special needs of various students.

### Suggested teaching aids

- Charts on the preparation and test for chlorine.
- Learner's book.
- Reagents and apparatus.

### Improvisation

Where there are no commercial charts, you may come up with your own charts drawn on manila papers.

### Pre-requisite to the lesson

Take advantage of learners knowledge on preparation of nitrogen and sulphuric dioxide in the laboratory. Let them brainstorm how chlorine can be prepared in the laboratory.

### Suggested teaching and learning activities

1. Organise learners into convenient groups according to availability of resources to carry out Activity 4.1 in the Learner's Book.

**Note:** Inform them they will have to store some of the chlorine obtained for the next experiments.

2. Guide learners in setting up the apparatus and assist them during the experiments. Provide brailles for learners with visual impairment if available.
3. Instruct them to follow the procedure as laid out in the experiments.
4. After the experiment let them discuss their observations and findings after which they should do a presentation in class.

5. Build on their presentation to explain the preparation and test for chlorine as outlined in the Learner's Book as they take notes.
6. Summarise the lesson by bringing out the key points on preparation and test for chlorine gas.
7. End the lesson by instructing learners to attempt question in Self-evaluation Tests 4.1.

### Synthesis

This lesson introduces learners to laboratory preparation of chlorine gas, its physical properties and test. Learners should employ their observation skills and observatory to manipulate apparatus when carrying out activities in this lesson.

### Suggested lesson assessment

Assess whether the learning objectives of the lesson are being achieved by asking questions such as:

1. Where in nature is chlorine found?  
*Ans: In combined form for example rock salt, sea water and potassium chloride.*
2. State the physical properties of chlorine gas.  
*Ans: Green-yellow in colour, fairly soluble in water, easily liquefied.*

### Answers to Self-evaluation Test 4.1

Refer to Learner's book

1. a. They can prepare using:

- Concentrated hydrochloric acid + manganese dioxide or
  - Dilute hydrochloric acid + Potassium manganate(VII)
    - b. Prepare the gas in the fume chamber because it is poisonous.
2. Place a moist blue litmus paper into the gas, if it turns red immediately then gets bleached. This is a confirmatory test for chlorine gas.
  3. Halogens
  4. B
  5. 7
  6.  $\text{MnO}_2(\text{s}) + 4 \text{HCl}(\text{aq}) \rightarrow \text{MnCl}_2(\text{aq}) + \text{Cl}_2(\text{g}) + 2\text{H}_2\text{O}(\text{l})$
  7. B

## 4.2 Chemical properties and uses of chlorine

*Refer to Learner's Book*

### Lesson 2: Chemical properties and uses of chlorine (To be covered in four periods)

#### Specific objectives

By the end of the lesson, learners should be able to describe chemical properties and uses of chlorine.

#### Preparation for the lesson

1. This lesson will be taught in four periods and will involve conducting experiments in the laboratory.
2. Bring charts on chemical properties and uses of chlorine and textbooks for reference.

**Note:** When grouping learners during the activity consider the different abilities of learners and their various special needs.

#### Suggested teaching aids

- Charts on the chemical properties and uses of chlorine.
- Learner's book.
- Reagents and apparatus.

#### Pre-requisite to the lesson

Introduce the lesson by engaging learners on their knowledge of chemical properties of chlorine acid and its uses. Ask learners to state the properties of sulphur dioxide related to that of chlorine (i.e bleaching action.)

#### Suggested teaching and learning activities

1. Organise learners into convenient groups according to availability of resources to carry out Activities 4.2, 4.3, 4.4 and 4.5 in the learner's book respectively. They will use chlorine and stored from Activity 4.1.
2. Guide learners in setting up the apparatus and assist them during the experiments.
3. Instruct learners to follow the procedure as laid down in the experiments.
4. After each experiment let them discuss their observations and findings after which they should do a presentation in class.



5. Build on their presentation to explain the chemical properties of chlorine as follows:

- Begin with the reaction of chlorine with metals as outlined in the Learner's Book as they take notes. Use equations to illustrate this.
- Thereafter discuss the reaction of chlorine with hydrogen and water as outlined in the learner's book as they take notes. Use diagrams and equations to illustrate this.
- Bring to learners attention the bleaching action of chlorine as outlined in the learner's book as they take notes.
- End by discussing with learners the reaction of chlorine with sodium hydroxide and potassium hydroxide as outlined in the learner's book as they take notes.

6. Let learners be in pairs and look up for facts in textbooks and internet on uses of chlorine. They should write short notes and then present to the rest of the class. Research skills will be developed through these fact finding exercises.

7. Use their presentation and findings to discuss the uses of chlorine as outlined in the Learner's Book .

8. Show learners a chart on the uses of chlorine and let them itemise the uses.

9. Summarise the lesson by bringing

out the key points on the chemical properties and uses of chlorine.

10. End the lesson by instructing learners to attempt question in Self-evaluation Test 4.2.

### Synthesis

This lesson is on investigation of the chemical properties and uses of chlorine. The activities carried out during the lesson should help learners to develop knowledge skills and attitude that will be of help in learners lives.

### Suggested lesson assessment

Assess whether the learning objectives of the lesson are being achieved by asking questions such as:

1. State chemical properties of chlorine.

*Ans: Reacts with metals, hydrogen, water and alkalis.*

2. State two uses of chlorine.

*Ans: Treatment of water and sewage systems, manufacture of domestic bleaches, HCl.*

### Answers to Self-evaluation Test 4.2

Refer to Learner's Book

1. a)  $2\text{Fe}(s) + 3\text{Cl}_2(g) \rightarrow 2\text{FeCl}_3(s)$

b)  $\text{Mg}(s) + \text{Cl}_2(g) \rightarrow \text{MgCl}_2(s)$

2. Bleaching by sulphur dioxide is

temporary as atmospheric oxygen re-oxidizes the bleached matter after some time i.e. sulphur dioxide is a temporary bleaching agent, unlike chlorine which is a permanent bleaching agent.

### 4.3 Compounds of chlorine

*Refer to Learner's Book*

#### **Lesson 3: Preparation, properties and uses of various chlorine compounds (To be covered in four periods)**

##### **Specific objectives**

By the end of the lesson, learners should be able to describe preparation, properties and uses of various chlorine compounds.

##### **Preparation for the lesson**

1. This lesson will be taught in four periods and will involve experiments conducted in the laboratory.
2. Bring charts on the preparation, properties and uses of compounds of chlorine compounds and textbooks for reference.

**Note:** When grouping learners you should consider their different abilities and their special needs.

##### **Suggested teaching aids**

- Charts on the preparation, properties and uses of chlorine compounds.
- Learner's Book.
- Reagents and apparatus.

##### **Pre-requisites for the lesson**

This lesson is about compound of chlorine namely hydrogen chloride gas, hydrochloric acid and sodium chloride (table salt). Let learners brainstorm how these products come about and write short notes.

##### **a. Hydrogen chloride**

1. Organise learners into convenient groups according to availability of resources to carry out Activities 4.6 and 4.7 in the Learner's Book respectively. Group work encourages team work and promotes cooperation and interpersonal skills development.
2. They will first do activity 4.6 then use the hydrogen chloride obtained for activity 4.7.
3. Guide learners in setting up the apparatus and assist them during the experiments.
4. Instruct learners to follow the procedures as laid down in the experiments accurately.
5. After each experiment let them discuss their observations and findings after which they should do a presentation to the rest of the class.

6. Build on their presentations to explain the laboratory preparation of hydrogen chloride as outlined in the Learner's Book using equations. Also discuss the physical and chemical properties of hydrogen chloride as outlined in the Learner's Book using relevant equations as they take notes.
7. Summarise by bringing out the key points on the preparation, properties and uses of hydrogen chloride.
8. Instruct learners to attempt the question in Self-evaluation Test 4.3.

#### **b. Sodium chloride**

9. Organise learners into convenient groups once more and carry out Activity 4.8 in the Learner's Book. Group work encourages team spirit and cooperation.
10. Guide learners in setting up the apparatus and assist them during the experiments.
11. Instruct them to carefully follow the procedures as laid down in the experiments.
12. After each experiment let them discuss their observations and findings after which they will do a presentation in class.
13. Build on their presentation to explain the laboratory preparation of sodium chloride and its properties

as outlined in the Learner's Book using equations as they take notes.

14. In pairs let learners carry out activity 4.9 in the Learner's Book. They should make a list of the common uses of sodium hydroxide.
15. Build on their list to explain uses sodium chloride and as outlined in the learner's book as they take notes
16. Summarise by bringing out the key points on the uses of sodium hydroxide.

#### **c. Hydrochloric acid**

17. Organise learners into convenient groups according to availability of resources to carry out Activity 4.10 in Learner's Book.
18. Guide the learners in setting up the apparatus and assist them during the experiments.
19. Instruct learners to carefully follow the procedure as laid down in the experiments.
20. After each experiment let them discuss their observations and findings after which they will do a presentation in class.
21. Build on their presentation to explain

discuss the reaction of hydrochloric acid with metals, bases, manganese (IV) oxide and carbonates as outlined in the Learner's Book using equations as they take notes.

22. In pairs let learners carry out activity 4.11 in the Learner's Book.

They will make a list of the uses of hydrochloric acid.

23. Build on their list to explain uses of hydrochloric acid as outlined in the Learner's Book as they take notes.
24. Summarise by bringing out the key points on the properties and uses of hydrochloric acid.

### Notes

- Let learners' find out the facts about chlorine compound from textbooks and watch the video on the uses of chlorine compounds.
  - Show learners charts on uses of chlorine compounds and let them itemise the uses.
25. Summarise the lesson by bringing out the key points on the properties and uses of chlorine compounds.
26. End the lesson by instructing learners to attempt questions in Self-evaluation Test 4.4.

### Synthesis

This lesson imparts learners with knowledge on laboratory preparation of chlorine compounds, their physical and chemical properties and uses. The activities carried out during the lesson

will help learners to develop knowledge and attitude and also be equipped with lifelong skills.

### Suggested lesson assessment

Assess whether the learning objectives of the lesson are being achieved by asking questions such as:

1. State three physical properties of hydrogen chloride.

*Ans: Colourless gas, pungent choking smell and soluble in water.*

2. State uses of hydrochloric acid.

*Ans: Used in the manufacture of aniline dyes and drugs, photographic materials.*

### Answers to Self-evaluation Test

#### 4.3

Refer to Learner's Book

1. Refer to learner's book, fig 4.10
- 2.

- Dip a glass rod with concentrated ammonia solution into the suspected gas. Formation of white fumes (hydrogen chloride gas) is a confirmatory test.
- Dip a glass rod with silver nitrate solution into suspected gas. Formation of white precipitate is a confirmatory test.

### Answers to Self-evaluation Test

#### 4.4

Refer to Learner's Book

1. It is commonly used as a condiment and food preservative in form of

table salt. Large quantities of sodium chloride are used in many industrial processes and it is a major source of sodium and chlorine compounds used as feedstock for further chemical syntheses.

2. a) • Manganese dioxide -

Chlorine gas was produced

- $\text{MnO}_2(\text{s}) + 4\text{HCl}(\text{aq}) \rightarrow \text{MnCl}_2(\text{aq}) + 2\text{H}_2\text{O}(\text{l}) + \text{Cl}_2(\text{g})$
- Zinc granules - Hydrogen gas was produced.

$\text{Zn}(\text{s}) + 2\text{HCl}(\text{aq}) \rightarrow \text{ZnCl}_2(\text{aq}) + \text{H}_2(\text{g})$

- Sodium carbonate - Carbon dioxide gas effervescence was produced.

$\text{Na}_2\text{CO}_3(\text{aq}) + \text{Cl}_2(\text{g}) \rightarrow 2\text{NaCl}(\text{aq}) + \text{CO}_2(\text{g}) + \text{H}_2\text{O}(\text{l})$

- 3) Used in cleaning surfaces, manufacture of aniline dyes and drugs, photographic materials.

#### 4.4 Tests for chlorides and other halides in solutions

Refer to Learner's Book

##### Lesson 4: Tests for chlorides and other halides in solutions (To be covered in two periods)

##### Specific objectives

By the end of the lesson, learners should be able to test for chlorides and other halides in solutions.

##### Preparation for the lesson

1. This lesson will be taught in two periods and it will involve a variety of practical activities carried out in the laboratory.
2. Bring charts on the chlorides

and other halides, text books for reference.

**Note:** When grouping learners during practical experiments you should consider the different abilities of learners and the special needs of various individuals.

##### Suggested teaching aids

- Charts on the tests for chlorides and other halides.
- Learner's book.
- Reagents and apparatus.

##### Improvisation

Where there are no commercial charts, you may come up with your own colour charts drawn on manila papers.

##### Pre-requisites to the lesson

Introduce the lesson by informing learners that to identify an unknown solution or substance we need to carry out some tests. These test enables us to ascertain the presence of those compounds. Ask learners to describe test for chlorine.

##### Suggested teaching and learning activities

1. Organise learners into convenient groups according to availability of resources to carry out Activity 4.12 in the Learner's Book.
2. Guide learners in setting up the apparatus and assist them during the experiments.
3. Instruct them to follow the procedure as laid down in the experiments. They will discuss their findings in groups then do a presentation.
4. Build on their presentation to explain the tests for chlorides and halides as outlined in the Learner's Book.

- Summarise the lesson by bringing out the key points on the test for chlorides and halides.
- End the lesson by instructing learners to attempt question in Self-evaluation Test 4.5.

### Synthesis

Use the suggested practical activities to help learners develop skills in testing for chlorides and oxides and appreciate the importance of this.

### Suggested lesson assessment

Assess whether the learning objectives of the lesson are being achieved by asking questions such as:

How do you test for chloride ions in solution?

*Ans: By adding silver nitrate solution, formation of white precipitate is a confirmatory test.*

### Answers to Self-evaluation Test 4.5 (Refer to learner's Book )

Use silver nitrate to test the various halides in solutions, for:

- $\text{Cl}^-$  White precipitate is formed
- $\text{Br}^-$  pale cream precipitate is formed
- $\text{I}^-$  pale yellow precipitate is formed

### Lesson 4.5: Environmental issues related to chlorine and its compounds (To be covered in 1 period)

*Refer to Learner's Book*

### Specific objectives

By the end of the lesson, learners should be able to:

- Appreciate the dangers caused by chlorine compounds to the environment.
- Carry out research on protection of the environment and hence protect natural resources.

### Preparation for the lesson

- This lesson will involve a research activity to establish the pollution effects of chlorine and its compounds to the environment.

### Suggested teaching aids

- Polluted environment with chlorine products or by products such as a factory.
- Video on the effects of chlorine compounds on the environment.
- Learner's Book.

### Pre-requisites to the lesson

Chlorine compounds just like carbon, nitrogen and sulphur are harmful to the environment. Learners need to appreciate the importance of keeping such compounds out of the environment. Introduce this by asking learners about the environmental effects of sulphur dioxide and nitrogen dioxide and relate some of these effects with those of chlorine compounds.

### Suggested teaching and learning activities

- Organise learners in pairs to carry out Activity 4.13 suggested of the Learner's Book.

- Instruct them to note down their findings which they will discuss and present to the rest of the class.
- Build on their findings to explain the effects of chlorine compounds on the environment and their mitigation as outlined in the learner's book as they take notes.
- Summarise the lesson by bringing out the key points on the effects of chlorine compounds on the environment.
- End the subtopic and topic by instructing learners to attempt Test your Competence 4.

### Synthesis

This lesson creates awareness to learners on the effects of chlorine compounds on the environment. At the end, learners should be knowledgeable on the destructive nature of compounds of chlorine.

### Suggested lesson assessment

Assess whether the learning objectives of the lesson were achieved by asking questions such as:

How can we minimise the effects of chlorine and its compounds on the environment?

*Ans: Use of alternative chemicals, reduce usage of chlorides, etc*

Assess learners attitude and values and their self-confidence during presentation of research work.

Plan to Give remedial activities to learners who are facing challenges.

### Summary of the unit

This unit deals with chlorine and its inorganic compounds. Ensure that learners through the various activities have understood the impact of chlorine and its inorganic compounds on the environment.

As well learners should have developed observation skills in research and preparation of chlorine and its compounds.

### Additional Information to the teacher

Chlorine, element with atomic number 17 in the Periodic Table, belongs to the halogens group. It is the second lightest halogen, after fluorine. Like other halogens, it is an extremely reactive element that readily forms the  $-1$  anion. Because of its high reactivity, chlorine is found in compounds. Free chlorine is rare, but exists as a dense, diatomic gas.

Although chlorine compounds have been used by man since ancient times, pure chlorine was not produced (on purpose) until 1774 when Carl Wilhelm Scheele reacted magnesium dioxide with Spiritus salis (now known as hydrochloric acid) to form chlorine gas. Pure chlorine is a greenish-yellow gas or liquid with a distinctive odour (like chlorine bleach).

The element name comes from its colour. The Greek word “chloros” means greenish-yellow.

Chlorine is the 3rd most abundant element in the ocean (about 1.9% by mass) and 21st most abundant element in the Earth’s crust.

There is so much chlorine in the Earth’s oceans that it would weigh 5x more than our present atmosphere, if it were somehow suddenly released as a gas.

Chlorine is essential for living organisms. In the human body, it’s found as the chloride ion, where it regulates osmotic pressure and pH and aids digestion in the stomach as hydrochloric acid. The element is usually obtained by eating salt, which is sodium chloride (NaCl). While it’s needed for survival, pure chlorine is extremely toxic. The gas irritates the respiratory system, skin, and eyes. Exposure to 1 part per thousand in air may cause death. Since many household chemicals contain chlorine compounds, it is risky to mix them because toxic gases may be released. In particular, it’s important to avoid mixing chlorine bleach with vinegar, ammonia, alcohol or acetone.

Because chlorine gas is toxic and heavier than air, it was used as a chemical weapon. The first use was in 1915 by the Germans in World War I. Later, the gas was also used by the Western Allies. The effectiveness of the gas was limited because its strong odour and distinctive colour alerted troops to its presence.

Soldiers could protect themselves from the gas by seeking higher ground and breathing through damp cloth, since chlorine dissolves in water.

Pure chlorine is obtained primarily by electrolysis of salt water. Chlorine is used to make drinking water safe, for bleaching, disinfection, textile processing, and to make numerous compounds. The compounds include chlorates, chloroform, synthetic rubber, carbon tetrachloride, and polyvinyl chloride. Chlorine compounds are used in medicines, plastics, antiseptics, insecticides, food, paint, solvents, and many other products. While chlorine is still used in refrigerants, the amount of chlorofluorocarbons (CFCs) released into the environment has dramatically declined. These compounds are believed to have contributed significantly to the destruction of the ozone layer.

Natural chlorine consists of two stable isotopes: chlorine-35 and chlorine-37. Numerous radioactive isotopes of chlorine have been produced.

The first chain reaction to be discovered was a chemical reaction involving chlorine, not a nuclear reaction, as you might expect. In 1913, Max Bodenstein observed a mixture of chlorine gas and hydrogen gas exploded upon exposure to light.

### **End of unit assesment**

This is presented in two sections:

- Answer to Test your Competence 4



- Additional end of unit ( consolidated activities.

## Answers to Test your Competence 4

Refer to Learner's Book

1. In combination form as sodium chloride in rock salt.
2. Using alternative chemicals, reduce reliability on chlorides, use of protective of clothing.
3. Purify/sterilise it
4. Gas
5. a) Chlorine gas  
b) Absorbs hydrogen chloride fumes.  
c) Drying agent.
6. a) A white solid is formed.  
b) Reddish brown crystals formed.
7. a)  $2\text{NaOH}(\text{aq}) + \text{Cl}_2(\text{g}) \rightarrow \text{NaCl}(\text{aq}) + \text{H}_2\text{O}(\text{l}) + \text{NaOCl}(\text{aq})$   
b) The hypochlorite in water forms hypochlorous acid (HOCl) which has bleaching properties.

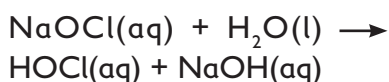

The oxygen atom in HOCl is readily given up.

8. a) A - Hydrogen chloride gas,  
C - Chlorine gas  
b) Silver chloride  
c) Magnesium
9. Pollution and health problems.

## b) Additional end unit assessment exercise (consolidation exercises)

1. A group of compounds called chlorofluoro-carbons have a wide range of uses but they also have harmful effects on the environment. State one:-

- (a) Use of chlorofluoro carbons
- b) Harmful effect of chlorofluoro carbons on the environment.
- c) Water from a town in Rwanda is suspected to contain chloride ions but not sulphate ions. Describe how the presence of the chloride ions in the water can be shown.

Ans:

(a) They are used as refrigerants, propellants for aerosols, for generating foamed plastics like expanded polystyrene or polyurethane foam, and as solvents for dry cleaning and for general degreasing purposes.

b) Their long lifespan in the atmosphere mean that some end up in the higher atmosphere (stratosphere) where they can destroy the ozone layer, thus reducing the protection it offers the earth from the sun's harmful UV rays.

CFCs also contribute to Global warming (through "the Greenhouse Effect"). Although the amounts emitted are relatively small, they have a powerful warming effect (a very high "Global warming Potential").

Inhalation of high levels of chlorofluorocarbons can affect the lungs, central nervous system, heart, liver and kidneys. Symptoms of exposure to chlorofluorocarbons can include drowsiness, slurred speech, disorientation, tingling sensations and weakness in the limbs. Exposure to extremely high levels of chlorofluorocarbons can result in death. Ingestion of chlorofluorocarbons can lead to nausea, irritation of the digestive tract and diarrhoea.

Dermal contact with chlorofluorocarbons can cause skin irritation and dermatitis. Chlorofluorocarbons are involved in the destruction of the stratospheric ozone layer resulting in increased exposure to UV radiation which is known to cause skin cancer.

c) Take small samples of water and add silver nitrate solution, a white precipitate formed soluble in dilute solution of ammonia confirm the presence of chloride ions.

2. The diagram shows a set up to produce and collect a sample of chloride gas.

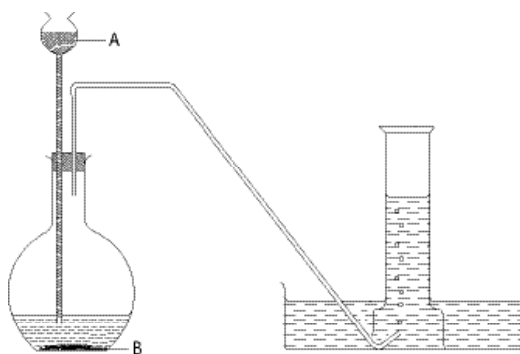

(a) Suggest substance that could be used as A and B.

(b) Write a balanced equation for the reaction between A and B.

(c) Give two uses of chlorine gas.

**Ans.**

(a)

A – Conc. HCl

B –  $\text{KMnO}_4$

(b)

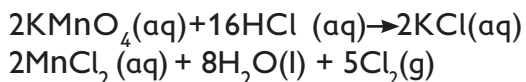

(c)

- Antiseptic/ disinfectant.
- Treats drinking water and pools.
- Industrial processes.

## Extended and remedial exercises

Remedial activities for below average learners	Extended activities for gifted and talented learners
<p>1. Encourage oral expression instead of written reports during class activities. This will enable them to express themselves better than when writing.</p> <p>2. Assist them with writing and balancing chemical equations.</p> <p><b>Remedial exercise for slow learners</b></p> <p>1. State any three physical properties of chlorine gas.</p> <p>2. State any three uses of chlorine gas.</p> <p><b>Answers to Remedial exercise for below average learners</b></p> <p>(a) A green yellow gas</p> <p>Unpleasant, irritating, choking smell.</p> <p>-Denser than air, that is why it is collected by downward delivery.</p> <p>(b) -In the manufacture of plastics e.g. PVC, insecticides and many organic compounds.</p> <p>-As a bleach in the pulp and textile industries.</p> <p>-for treating sewage and in sterilising water.</p>	<p>I (a) The figure below is a reaction scheme. Study it then answer the question that follow.</p> <div style="text-align: center;"> </div> <p>C (aq) and F(s) react with sodium hydroxide solution giving a dirty green precipitate and brown precipitate respectively. Gas D burns with a pop sound but E does not burn. Identify all the species A to H.</p> <p><b>Answers to HOT questions</b></p> <p>I.     A - hydrochloric acid</p> <p>          B – Carbonate</p> $\text{CO}_3^{2-}(\text{s}) + 2\text{HCl}(\text{aq}) \longrightarrow 2\text{Cl}^-(\text{aq}) + \text{H}_2\text{O}(\text{l}) + \text{CO}_2(\text{g})$ <p>          C - Iron (II) chloride</p> <p>          D Hydrogen gas</p> <p>          E - Chlorine gas</p> <p>          F - Iron (III) chloride</p> $2\text{Fe}(\text{s}) + 3\text{Cl}_2(\text{g}) \longrightarrow 2\text{FeCl}_3(\text{s})$ <p>          G - Silver chloride</p> <p>          H - Iron (III) nitrate solution</p> $\text{FeCl}_3 + 2\text{AgNO}_3(\text{aq}) \longrightarrow 2\text{AgCl}(\text{s}) + \text{Fe}(\text{NO}_3)_3(\text{aq})$

*Refer to Learner's Book*

## Key Unit Competence

After studying this unit, the learner should be able to describe and explain the effect of different conditions on the speed or rate of reactions.

## Learning objectives

Competency based curriculum embraces three categories of learning objectives, that is, knowledge and understanding,

skills acquisition and attitude and values. At the end of the unit, learners should have knowledge and understanding of the speed or rate of reactions and appreciate the importance of chemical reaction in everyday life like burning of fuel that provide energy to run the machine and vehicles.

**Table 5.1: Knowledge and understanding, skills and attitudes and values to be attained**

Knowledge and understanding	Skills	Attitudes and values
<ul style="list-style-type: none"> <li><input type="checkbox"/> Define the rate of a reaction.</li> <li><input type="checkbox"/> Describe the effects of different conditions on the speed of reactions</li> </ul>	<ul style="list-style-type: none"> <li><input type="checkbox"/> Observation skills in experiments that involve changes of colour.</li> <li><input type="checkbox"/> Research and scientific reporting skills.</li> <li><input type="checkbox"/> Interpret mass against time graphs for different reactions.</li> </ul>	<ul style="list-style-type: none"> <li><input type="checkbox"/> Develop a culture of working in a team during discussions and research.</li> <li><input type="checkbox"/> Appreciate that reactions in everyday life like burning and rusting happen at different rates.</li> <li><input type="checkbox"/> Respect for the procedures in an experiment.</li> </ul>

## Pre-requisite to the unit

Learners have already learnt about the states of matter i.e. solids, liquids and gases. They have also looked at the

kinetic theory of matter and the change of states of matter from one form to the other.

Review the topic of states of matter as learning will require this knowledge to relate to this topic of rates of reaction. This topic of rates of reaction involves interaction collision of particles in solids, liquids and gases. Therefore prior knowledge of states of matter is important.

### **Links to other subjects**

During the lessons, strive to bring to the attention of learners the fact that this topic is related to enzymes in chemicals of life and photosynthesis in Biology.

Attention should be brought to the learner that speed of chemical reactions is important especially in industries or factories because time is 'money'!

### **Background Information**

Essentially, a chemical reaction is the result of collisions between molecules. According to this collision model, if the collision is strong enough, it can break the chemical bonds in the reactants, resulting in a rearrangement of the reactants atoms to form products. The more the molecules collide, the faster the reaction. Increase in the numbers of collisions can be produced in two ways: either the concentrations of the reactants are increased, or the temperature is increased. In either case, more molecules are colliding at high frequency.

Increases of concentration and temperature can be applied together to produce an even faster reaction, but rates of reaction can also be increased by use of a catalyst, a substance that speeds up the reaction without participating in it either as a reactant or product. Catalysts are thus not consumed in the reaction. One very important example of a catalyst is an enzyme, which speeds up complex reactions in the human body. At ordinary body temperatures, these reactions are too slow, but the enzyme hastens them along. Thus human life can be said to depend on chemical reactions aided by a wondrous form of catalyst

### **Cross-cutting issues to be addressed**

#### **I. Inclusive learning**

All learners whether physically challenged or not should be encouraged to participate during lessons and practical activities. Make arrangement to take care of learners with special needs. In particular learners with visual impairment should be placed in front of the classroom. Provide braille if available for blind learners and large print text for those with sight problems.

Group physically challenged learners with others to assist them during movement and field trips and other practical activities. Furthermore, give these learners tasks they can manage comfortably during practicals.

## 2. Gender education

Both boys and girls should participate equally in all activities. Emphasise to learners that anybody irrespective of their gender can pursue a career in any area of chemistry. Give examples of role models who are successful in the careers locally.

## 3. Financial education

Emphasise the need to follow instructions, and during practical handle apparatus carefully in order to minimise breakages. They should also use reagents in specified quantities to minimize wastage. All these have financial implications in terms of costs.

## 4. Standardisation culture

Emphasise the need to use chemicals and apparatus certified by the Rwanda Standards Board.

## 5. Environment and sustainability education

Bring to the attention of learners the fact that sulphur dioxide is an air pollutant and any used salts must be properly disposed after experiment.

## 6. Peace and values education

Emphasise to learners the importance of working harmoniously with each other during group work and class activities.

## Generic competencies

### 1. Research skills

Guide learners on how to find information regarding various topics, on how to come up with summarised notes from a large body of text and on how to do internet searches for the various content areas they are looking for.

### 2. Communication in English

Communication in English will be improved when learners freely participate in the discussions and presentations. Encourage all learners irrespective of their abilities to participate in group discussions, during presentations by asking questions and during question and answer sessions to either introduce or wrap up the lessons.

### 3. Cooperation and interpersonal management and life skills

During group discussions and pair-work let learners engage one another by giving a chance for all to participate. Also, during group presentations, you can allow rotational presentations within the group members. Gifted learners should help in coming up with presentation content as slow learners contribute.

**Note:** You should allow slow learners to do presentations as well and correct them where they go wrong. Advise learners to appreciate the different abilities of their group members and accommodate each other's views.

#### 4. Critical thinking and problem solving skills

This competence will be developed by learners as they answer the probing questions at the beginning of this unit and as they discuss the results of the various practical activities. Guide learners to discover for themselves how to determine rates of reactions. This competence will also come about as learners think about their findings in the activities and as they give out their suggestions.

#### 5. Lifelong learning skills

Skills required under rates of reactions are important in careers such as quality control and output rate in industry.

#### Key words in this unit and their meanings

- **Activation energy** – the minimum quantity of energy that the reacting species must possess in order to undergo a specified reaction.
- **Catalyst** – substance which increase the rate of a chemical reaction but remain unchanged at the end of reaction.
- **Collision** – an instance of one moving particle striking violently against another.
- **Energy** – the strength and power required to sustain a chemical

reaction.

- **Product** – a new substance that is formed during or at the end of a chemical reaction.
- **Reactant** – a substance that takes part in and undergoes change during a reaction.
- **Rate of reaction** – change of an amount or concentration of a particular reactant or product per unit time.

#### Guidance on the brain teaser

As earlier mentioned, this topic is about the rate of chemical reactions and its importance in everyday life. Let learners Perform Activity 5.1 and answer the following study questions:

- (a) How long does it take the nails to rust?
- (b) How long does it take a given magnesium ribbon to burn in a flame?
- (c) How long does it take charcoal to burn completely?

Guide learners into discovering what they will learn in this unit based on their discussions. Further, emphasise the need for taking this topic seriously in the course of the lessons as it can lead to careers such as pharmacy in future.

## Attention to special educational need

Support for multi-ability learning	Support for special needs learning
<ul style="list-style-type: none"> <li><input type="checkbox"/> Guide the progressive gradual learners during the experimental activities. Assist them to recognize the apparatus and reagents used.</li> <li><input type="checkbox"/> Instruct gifted learners to help the gradual learners during the procedure.</li> <li><input type="checkbox"/> Ensure all learners work as a team during class activities to avoid accidents/ incidents.</li> <li><input type="checkbox"/> Give all learners equal opportunities during presentations.</li> </ul>	<ul style="list-style-type: none"> <li><input type="checkbox"/> Provide large diagrams and graphs for special needs learners with sight problems.</li> <li><input type="checkbox"/> Physically challenged learners to be assisted when moving around during the experimental activities.</li> <li><input type="checkbox"/> During practicals, allocate roles to physically challenged that they can easily handle.</li> </ul>

## List of lessons

Lesson Number	Lesson title	No. of periods
1	Effect of temperature on rate of chemical reaction	2
2	Effect of concentration on rate of chemical reaction	2
3	Effect of particle size on the rate of chemical reaction	2
4	Effect of catalyst on the rate of chemical reaction	2
5	Effect of pressure on reaction rate	1
6	Effect light on the rate of reaction	2
7	End of unit assesment text	1

### 5.1 Effect of different conditions on rate and speed of reaction

#### Lesson 1: Investigating the effect of temperature on rate of reaction (To be covered in two periods)

Refer to Learner's Book

#### Specific objectives

By the end of the lesson, learners should be able to

- Define rate of reaction.
- Explain the effect of temperature on reaction rate.
- Appreciate the importance of temperature in increasing the rate of reactions in everyday life.

#### Preparation for the lesson

1. This lesson will involve practical activities and discussion groups. The setting should therefore be in the laboratory.



**Note:** When grouping learners, you should consider the different abilities of learners and the special needs learning groups.

2. Provide the experiments procedures and the various apparatus to the learners.
3. Bring all related apparatus and ensure that all the apparatus are working before the lesson begins.
4. Also, ensure that the Internet is working if you have a computer laboratory or any other form of internet connectivity such as WIFI or modem. This should be done in advance and prepare a relevant video as well.

### Suggested teaching aids

- Various apparatus as listed in activities 5.1 and 5.2 in Learner's Book.
- Video on effect of temperature on reacting rate).
- Learner's book.

### Pre-requisite to this lesson

Learners have learnt about the effects of temperature on enzymes in Biology. They are also aware of the importance of heat used at home for example cooking. Relate these and others to daily activities involving increase or decrease in temperature to rate of reaction in the laboratory.

### Suggested teaching and learning activities

1. Introduce the unit as explained under guidance on activities involving different reaction rates then narrow down to the lesson.
2. Ask probing questions to introduce the lesson. Such questions may include:
  - What is a chemical reaction?  
**Ans:** *process that involves the formation of new substances from reactants, change in mass, evolution or absorption of energy, etc.*
  - Can you name some chemical reactions that occur in nature?  
**Ans:** *Respiration, photosynthesis, rusting etc.*
3. Introduce Activity 5.1 in the Learner's Book. This is a group experiment activity intended to bring out the idea of rate of reaction. Provide learners with the materials needed for the activity. Instruct them to follow the procedure as stipulated in the experiment.
4. Let learners have a brief discussion session on their findings then write summary notes. Correct them as is appropriate. Then discuss the definition of reaction rate as outlined in the Learner's Book.
5. Introduce the factors that affect the rate of reactions. You will tackle each one at a time.

6. Begin with investigating the effect of temperature on rate of reaction, use activity 5.2.
7. Organise learners into convenient groups according to availability of resources to carry out Activity 5.2 in the Learner's Book.
8. Guide learners in setting up the apparatus and assist them during the experiments. Instruct them to follow the procedure as laid out in the experiments.
9. After the experiment let them discuss their observations and findings after which they will do a presentation in class.
10. Let the learners make proper observations, record the results from the experiment, plot the graph of  $1/\text{time}$  against temperature and comment on the shape of the graph.
11. Build on their presentation to explain the effects of temperature on the rate of reaction as outlined in the Learner's Book using equations.
12. Let learners watch the video carefully in the absence of apparatus. They should note how the temperature affects the rate of reaction.
13. Help learners to summarise the lesson by highlighting the key points, which should include the rate of

reaction definition and interpret the graph of effect of temperature on the rate of reaction.

### Synthesis

The lesson introduces learners to the rate of reactions and the effect of temperature on rates of reaction. Carrying out the activities, learners are able to acquire skills of observation, drawing and interpreting graphs and appreciate that reactions happens at different rates.

### Suggested lesson assessment

Assess whether the learning objectives of the lesson are being met by asking questions such as:

1. What did you learn in this lesson?

**Ans:** *the definition of rate of chemical reactions. Appreciate how different reactions occur at different rates.*

*How to conduct experiment to investigate the effect of temperature on rate of reaction.*

2. Suppose chemical reactions in industry were allowed to take place at low temperatures, suggest what would happen?

**Ans:** *Some reactions would proceed very slowly leading to under production, under utilisation of human resources and inability to meet market for essential consumer products.*

## Lesson 2: Effect of concentration on the rate of reaction (To be covered in two periods)

Refer to Learner's Book

### Specific objectives

By the end of the lesson, learners should be able to:

- Explain the effect of concentration on the rate of a chemical reaction.
- Appreciate the importance of effect of concentration on rate of reaction in everyday life.

### Preparation for the lesson

1. This lesson as well involves practical activities and group discussions therefore will be carried out in the laboratory.
2. Provide the experimental procedure and the necessary apparatus to the learners. Ensure that the apparatus are working before the lesson begins.
4. Also, ensure that the internet is working if you have a computer simulation laboratory or any other form of internet connectivity such as WIFI or modem. This should be done in advance and acquisition of relevant video for the lesson if possible).

### Suggested teaching aids

- Various apparatus listed in activity 5.3 and the procedure for each group.
- Video link on effect of concentration on reaction rate.
- Learner's Book.

## Pre-requisite to this unit

Learners carry out reactions involving concentrations daily in their lives. Remind learners of such reactions, for example, during preparation of tea. Ask them about the effect of adding tea leaves to tea. Related to reactions depend on the concentration of reactants to form desired product.

### Suggested teaching and learning activities

1. Ask probing questions from previous lesson to introduce lesson. Such questions may include:
  - How does concentration affect the rate of reaction?

*Ans: (The higher the concentration the higher the rate of reaction)*
2. Organise learners into convenient groups according to availability of resources to carry out Activity 5.3 in the learner's book.
3. Guide learners in setting up the apparatus and assist them during the experiments. Instruct them to follow the procedure as laid down in the experiments.
4. After the experiment, let them discuss their observations and findings after which they will do a presentation in class.
5. Let the learners make proper observations, record the results from the experiment, plot the graph of  $1/\text{time}$  against concentration and comment on the shape of the graph.

- Build on their presentation to explain the effects of concentration on the rate of reaction as outlined in the Learner's Book.
- Let learners watch the video carefully, they should note how the concentration affects the rate of reaction.
- Provide summary of the lesson by highlighting the key points, which should include the rate of reaction definition and how to illustrate the effects of concentration on reaction rate in a graph.

### Synthesis

This lesson introduces learners to the effects of concentration on the rate of chemical reactions. Guide learners to discover how rates of chemical reactions vary with concentration using the suggested activities.

### Suggested lesson assessment

Assess whether the learning objectives of the lesson are being met by asking questions such as:

- Briefly describe how concentration affects the rate of chemical reaction.

**Ans:** *Increase in concentration increases the rate of chemical reaction because there is an increase in collision between the particles.*

- Explain what would happen to photosynthesis in plants if the

amount of carbon dioxide was low in the atmosphere?

**Ans:** *The rate of photosynthesis would be very slow hence some plants would die due to lack of enough food.*

### Lesson 3: Effect of particle size on the rate of reaction (To be covered in two periods)

Refer to Learner's Book

#### Specific objectives

By the end of the lesson, learners should be able to:

- Describe the effect of particle size on the rate of a chemical reaction.
- Appreciate the effect of particle size on the rates of reactions in everyday life.

#### Preparation for the lesson

- This lesson will involve performing experiment in the laboratory.
- Provide the experiment procedure and the apparatus to the learners. Ensure that the set up is working well before the lesson begins.
- Also, ensure that the internet is working if you have a computer laboratory or any other form of internet connectivity such as WIFI or modem. This should be done in advance.

#### Suggested teaching aids

- Charts showing the arrangement of the apparatus and the procedure for each group.
- Video link.
- Learner's Book.

### Pre-requisite to the lesson

Learners in their daily lives have come across processes that require smaller particles size than big one in order for the process to happen quickly. For example, when preparing Kaunga why use maize flour instead of maize grains. Remind them why this is so then relate it to this lesson.

### Suggested teaching and learning activities

1. Ask probing questions to introduce the lesson. Such as the one under pre-requisite: State effect of particle size on the rate of reactions.

**Ans:** *Smaller particle size increases the surface area hence increases the rate of reaction*

2. Organise learners into convenient groups according to availability of resources to carry out Activity 5.4 in the Learner's Book.
3. Guide learners in setting up the apparatus and assist them during the experiments. Instruct them to follow the procedure as given for the experiments
4. After the experiment, let them discuss their observations and findings after which they will do a presentation in class.
5. Let the learners make proper observations, record the results obtained, plot the graph of volume of gas formed against time and comment on the shape of the graph.

6. Build on their presentation to explain the effects of particle size on the rate of reaction as outlined in the Learner's Book.
7. Help learners to summarise the lesson by highlighting the key points, which should include the rate of reaction definition and how the particle size affects the rate of reaction and plotting the experiment results in a graph.

### Synthesis

This lesson seeks to show learners how particle size affects the rate of a chemical reaction. Use the experiments suggested to prove the fact that the smaller the particle size the faster the rate of a chemical reaction.

### Suggested lesson assessment

Assess whether the learning objectives of the lesson are being achieved by asking questions such as:

- Describe the effect of particle size on the rate of chemical reaction.

*Ans: Increase in particle size decreases the rate of reaction and vice versa.*

### Answers to Self-evaluation Test 5.1

Refer to Learner's Book

1. A
2. C
3. B
4. A
5. A
6. A
7. A

## **Lesson 4: The effect of catalyst on the rate of reaction (To be covered in two periods)**

Refer to Learner's book

### **Specific objectives**

By the end of the lesson, learners should be able to:

- Explain the effect of catalyst on the rate of a chemical reaction.
- Relate the importance of catalyst in everyday life to rates of chemical reactions (use of enzymes in metabolic processes in our bodies).

### **Preparation for the lesson**

1. This lesson will involve performing an experiment. It will therefore be conducted in the laboratory.
2. Provide the experiment procedure and necessary apparatus to the learners. Ensure that all the apparatus are working before the lesson begins.
4. Also, ensure that the internet is working if you have a computer laboratory or any other form of internet connectivity such as WIFI or modem. This should be done in advance and avail relevant video for the lesson if possible.

### **Suggested teaching aids**

- Charts with diagrams showing the arrangement of the apparatus and the procedure for the activities.
- Learners book.

### **Pre-requisite to the unit**

Learners have learnt about the action of enzymes on food substances in Biology. Enzymes are catalysts.

Use this concept to explain how catalyst affect the rate of chemical reaction.

## **Suggested teaching and learning activities**

1. Ask probing questions to introduce the lesson. Such questions may include:

- How does a catalyst affect the rate of reaction?

*Ans: Catalysts increase the rate of reaction by reducing the activation energy of the reactants.*

2. Introduce Activity 5.5 in the Learner's Book, this activity is meant to investigate the effect of catalyst on rate of reaction.
3. Organise learners into convenient groups according to availability of resources to carry out the activity.
4. Guide learners in setting up the apparatus and assist them during the experiments. Instruct them to follow the procedure as laid out in the activity.
5. After the experiment let them discuss their observations and findings after which they will do a presentation in class.
6. Build on their presentation to explain the effects of catalyst on the rate of reaction as outlined in the Learner's Book .
7. Build on their presentation to explain the effects of catalyst on the rate of reaction as outlined in the Learner's Book
8. Let learners watch the video carefully in case the apparatus and reagent are not available. They should note how the catalyst affects the rate of reaction.

9. Let learners make proper observations, on how long it takes for the bubbles to be produced when copper sulphate is used and when not used.
10. Help learners to summarise the lesson by highlighting the key points, which should include the rate of reaction definition and how the catalyst affects the rate of reaction using a graph illustration.

### Synthesis

This lesson intends to create awareness of how a catalyst affect the rate of chemical reaction. Learners through watching the video or performing the experiment should describe how it affects the reaction rate.

### Suggested lesson assessment

Assess whether the learning objective of the lesson was met by asking questions such as:

- What would happen if the enzymes were not present in our bodies for digestion?

**Ans:** *The rate of food digestion in the body would be very slow.*

### Lesson 5: The effect of pressure on the rate of reaction (To be covered in one period)

Refer to Learner's Book

### Specific objectives

By the end of the lesson, learners should be able to explain how pressure affects the rate of reaction.

### Preparation for the lesson

1. This lesson will involve a research activity either using textbooks in the library or using the internet group.s
2. Discussion and presentation of reports of the research.

### Suggested teaching aids

- Charts on various diagrams showing how gaseous particles react.
- Learner's Book.

### Pre-requisite to the lesson

Learners deal with pressure every day in their lives. Use this to relate how pressure can be harnessed positively to bring about change in chemical reactions.

### Suggested teaching and learning activities

1. Ask learners to go to the library and research in textbooks how pressure affect the rate of reaction for gaseous molecules.They can also do internet searches.
2. Back in class, put learners in groups of five depending on the size of the class to harmonize their findings. Let them choose a group leader to do a presentation to the rest of the class.
3. After the presentations, guide learners to write short notes and draw diagrams to show how gaseous molecule react as shown in the Learner's Book .
4. Help learners to summarise the lesson by writing short notes on how



pressure affect the rate of reaction in their note books.

### Synthesis

This lesson introduces the effect of pressure on reaction rate to learners. Guide learners through research and discussion to discover how pressure affects the rate of reaction.

### Suggested lesson assessment

Assess whether the learning objective of the lesson was met by asking questions such as:

1. Describe how pressure is related to concentration of a gas at constant temperature.

**Ans:** *The higher the pressure the higher the concentration of gas molecules per unit area.*

2. Describe how pressure affect the rate of reaction for gaseous reacting molecules.

**Ans:** *The higher the pressure the higher the rate of reaction.*

### Lesson 6: Effect of light on the rate of reaction (To be covered in two period)

Refer to Learner's Book

### Specific objectives

By the end of the lesson, learners should be able to explain the effect of light on the rate of reaction.

### Preparation for the lesson

This lesson involves a practical activity and investigating the effect of light on silver bromide. Collect the required material sand ensure that they are working.

### Suggested teaching aids

- Apparatus and other materials required for the experiment.
- Chart having the experiment procedure or guidelines.

### Pre-requisite to the lesson

Learners use light every day. They are also aware that plants require light for the process of photosynthesis. Use the example above to explain to learners the importance of light in chemical reactions. Ask learners the importance of light to plants.

### Suggested teaching and learning activities

1. You may begin this lesson by asking learners to mention the factors that affect the rate of reaction giving a brief explanation for each. Then narrow down to light. Use Activity 5.6 in the Learner's Book .
2. Organise learners to make groups and perform the experiment as outlined in the procedures. Instruct them to answer the study questions in their groups. They should write a report and make presentation of their findings.



3. After the presentations, discuss with learners the effects of light on the rate of chemical reactions as outlined in the Learner's Book.
4. Help learners to summarise the lesson by writing short notes on how light affect the rate of reaction for particular processes in their note books
5. End the lesson and topic by instructing learners to attempt Self-evaluation Test 5.2 and Test your Competence 5.
4. Powdered calcium carbonate has a large surface area as compared to marble chips.
5. A
6. a. Nickel carbonate + hydrochloric acid  $\rightarrow$  nickel chloride + carbonic acid  
b. Y, because its reactions occurred faster than X.
7. a. Syringe  
b. Increase reaction rate  
c. A catalyst

### Synthesis

This lesson introduces the concept of light on how it affect the rate of reaction. Learners should be able to note the importance of light in chemical reactions in everyday life for example in photosynthesis and photography.

### Suggested lesson assessment

Assess whether the learning objectives of the lesson have been met by asking questions such as:

1. How does light affect the rate of a chemical reaction?

*Light becomes a limiting factor when present in less amounts than required.*

### Answers to Self-evaluation Test

#### 5.2

Refer to Learner's book

- 1.a) Oxygen  
b) Manganese dioxide ( $\text{MnO}_2$ )
2. B
3. D

8. a. A substance that acts as a catalyst to bring about a specific biochemical reaction in organisms.  
b. Decomposition of hydrogen peroxide since liver has enzyme catalase.  
c. High temperatures denatures enzyme activities.

### Summary of the unit

This unit introduces learners to rates of reactions and factors that affect rates of reactions. The factors that affect rate of reactions are given together with activities that support them. The unit further explores drawing of graphs to illustrate rates of reaction for each factor. Relate all the factors to the rate of reaction for the understanding of the leaners and link them to day to day life activities.

## **Additional information for the teacher**

The rate of a reaction is the speed at which a chemical reaction happens. If a reaction has a slow rate, that means the molecules combine at a slower speed than a reaction with a high rate. Some reactions take hundreds, maybe even thousands, of years while others can happen in less than one second. If you want to think of a very slow reaction, think about how long it takes plants and ancient fish to become fossils (carbonisation). The rate of reaction also depends on the type of molecules that are combining. If there are low concentrations of an essential element or compound, the reaction will be slower. There is another big idea for rates of reaction called collision theory. The collision theory says that as more collisions in a system occur, there will be more chances of molecules bouncing onto each other. If you have more possible successful collisions there is a higher chance that the molecules will complete the reaction much faster. The reaction will happen faster which means the rate of that reaction will increase. Think about how slowly molecules move in honey when compared to your soda even though they are both liquids. There are a lower number of collisions in the honey because of stronger intermolecular forces (forces between molecules). The greater forces mean that honey has a higher viscosity than the soda water.

## **Factors that affect rate of reaction**

Reactions happen - no matter what. Chemicals are always combining or breaking down. The reactions happen over and over, but not always at the same speed. A few things affect the overall speed of the reaction and the number of collisions that can occur.

**a. Temperature:** When you raise the temperature of a system, the molecules bounce around a lot more. They have more energy. When they bounce around more, they are more likely to collide. That fact means they are also more likely to combine. When you lower the temperature, the molecules have less energy and are likely to collide less. That temperature drop lowers the rate of the reaction. In the chemistry laboratory sometimes you regulate the amount and intensity of solutions so that the temperature of the system stays at desired level to avoid faster rate of reaction e.g reaction between hydrochloric acid and potassium manganate(VII).

**b. Concentration:** If there is more of a substance in a system, there is a greater chance that molecules will collide and speed up the rate of the reaction. If there is less of something, there will be fewer collisions and the reaction will probably happen at a slower speed. Sometimes, when you are in a chemistry lab, you will add one solution to another. When you want the rate of reaction to be slower, you will add only a few drops at a time instead of the entire beaker.

**c. Pressure:** Pressure affects the rate of reaction, especially when you are dealing with gases. When you increase the pressure, the molecules have less space in which they can move. That greater **density** of molecules increases the number of collisions. When you decrease the pressure, molecules don't hit each other as often and the rate of reaction decreases. Pressure is also related to concentration and volume. By decreasing the volume available to the molecules of gas, you are increasing the concentration of molecules in a specific space. You should also remember that changing the pressure of a system only works well for gases. Generally, reaction rates for solids and liquids remain unaffected by increases in pressure.

### Measuring reaction rates

Scientists like to know the rates of reactions. They like to measure different kinds of rates too. Each rate that can be measured tells scientists something different about the reaction. We're going to take a little time to cover a few different measures of reaction rates.

**Forward Rate:** The rate of the forward reaction when reactants combine to become products.

**Reverse Rate:** The rate of the reverse reaction when products disintegrate to become reactants.

**Average Rate:** The speed of the entire reaction from start to finish.

**Instantaneous Rate:** The speed of the reaction at one moment in time.

Some reactions can happen quickly at the start and then slow down. You have one average rate, but the instantaneous rates can tell you the whole story.

Scientists measure all of these rates by finding out the concentrations of the molecules in the mixture. If you find out the concentration of molecules at two different times, you can find out what direction the reaction is moving toward and how fast it is going. Even if the concentrations are equal at the two points of measurement, scientists still learn something. If the concentrations are stable during two measurements, the reaction is at an equilibrium point.

There is still more to know about measuring the rates of reactions. Since many reactions happen in several steps, the rate for each step needs to be measured. There will always be one step that happens at the slowest speed. That slowest step is called the rate-limiting step. That rate-limiting step is the one reaction that really determines how fast the overall reaction can happen. If you have six steps in your series of reactions and the third step goes incredibly slow, that is the rate-limiting step. As far as the overall reaction is concerned, none of the other rates really matter. If you want to speed up the overall reaction, you would focus on that slowest step.

**Note:** If you only speed up one step, another step may become the new rate-limiting step. You should always understand how all of the steps are involved in the overall reaction.

## End of unit assessment

This section is divided into two parts:

- Answers to test your competences
- Additional exercises for unit assessment (consolidation exercises)

### (a) Answers to Test your Competency 5

Refer to learner's book

- Increasing the number of reacting particles (concentration) and the heat energy of reacting particles (temperature) increases the rate of reaction. Increasing the velocity of reacting particles results in more fruitful collisions, providing the necessary activation energy required for the reaction to occur.
  - Results to an increase in surface area hence more contact for collision of reacting particles.
  - Reduces the activation energy required for the reactants.
  - It does not.
- Measuring the volume of carbon dioxide produced.
  - Observing the time it takes for disappearance of a cross sign drawn on a piece of paper placed under the beaker where the reaction is taking place.
  - Measuring the volume of oxygen produced or how fast the decomposition is taking place.
- collide.
  - rate.
  - temperature, kinetic, move, faster
  - Concentration, rate
  - Solid/big sized, small, surface area, concentration, collision
  - Catalyst, used, reused.
- Diagram of similar set up as that in the Learner's Book fig 5.8 can be used.
  - Check the graph drawn by each learner if correct.
  - Yes
  - At the beginning.
    - Many particles are present.
  - Most reactants have taken part in the reaction, only few left.
  - Read from the graph.
  - Read from the graph.
  - $2\text{H}_2\text{O}_2(\text{aq}) \rightarrow \text{O}_2(\text{g}) + 2\text{H}_2\text{O}(\text{l})$
- Check for correct graph.
  - At 6 minutes because the loss in mass/g slowed at this point while it should be rising steadily as the rest.
  - $\text{CaCO}_3(\text{s}) + 2\text{HCl}(\text{aq}) \rightarrow \text{CaCl}_2(\text{aq}) + \text{CO}_2(\text{g}) + \text{H}_2\text{O}(\text{l})$

## (b) Additional exercises for end unit assessment (consolidation exercises)

1. An experiment was carried out to study the reaction between magnesium ribbon and hydrochloric acid. The word equation for this reaction is:

*Magnesium + Hydrochloric acid*   
*Magnesium chloride + Hydrogen gas*

a) What would you see when this reaction is taking place?

*Ans: Bubbles of gas/hydrogen/effervescence/metal fizzes.*

b) Give three ways in which the rate of reaction could be increased.

*Ans: Any three from:*

- *Increase the temperature/heat the mixture.*
- *Increase concentration of acid*
- *Add more magnesium metal*
- *Cut up/powder the magnesium*

2. The following graphs were obtained in an experiment to look at the reaction rate between nickel carbonate and hydrochloric acid:

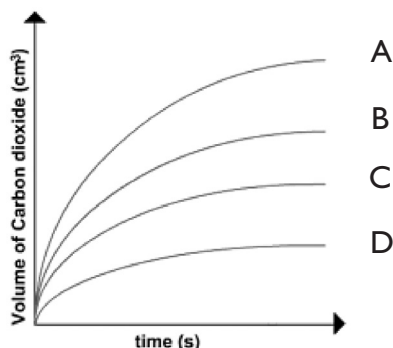

a) Write a word equation for the reaction between nickel carbonate and hydrochloric acid.

*Ans: Nickel carbonate + hydrochloric acid*   
*nickel chloride + carbon dioxide + water*

b) Which of the graphs shows the reaction that had the most concentrated hydrochloric acid? Explain your answer.

*Ans: A - because the graph is the steepest showing carbon dioxide is made at the fastest rate.*

3. Hydrogen peroxide decomposes at room temperature to give oxygen and water. The word equation for the reaction is:

Hydrogen peroxide  $\rightarrow$  oxygen + water

a) Which piece of apparatus could be used to measure the rate of this reaction?

*Ans: Gas syringe/inverted measuring cylinder full of water/electronic balance.*

- b) What effect would adding manganese dioxide have on the rate of this reaction?

*Ans: The rate of reaction would increase.*

- c) What name do we give to chemicals like manganese dioxide?

*Ans: Catalyst*

4. Most chemical reactions that take place in living organisms involve enzymes.

- a) Explain the term 'enzyme'.

*Ans: A biological catalyst*

- b) Catalase is an enzyme that is found in liver. It can cause a change in the decomposition of hydrogen peroxide. What effect would you expect if a piece of liver was placed in hydrogen peroxide solution?

*Ans: Rate would increase of decomposition/oxygen production is made faster.*

- c) If manganese dioxide is added to hydrogen peroxide, the rate of reaction increases. If the mixture is heated to 80°C the reaction is more vigorous. However, if the same is done with a piece of liver, the reaction rate is less at 80°C. Explain these observations.

*Ans: Manganese dioxide is a chemical catalyst. When the mixture is heated, reaction rate is increased due to the*

*usual effect of increased temperature on reaction rate.*

*Catalase is denatured/broken down at higher temperatures (over 60°C) since it is a biological catalyst. Heating the solution at those temperatures destroys the catalyst and so its effect is lost - rate is lowered.*

5. Explain why increasing the (a) concentration (b) temperature of reacting particles increases the rate of a reaction.

*Ans:*

- a) *Increasing the concentration increases the number of reacting particles per unit volume. This increases the number of collisions between reacting particles. As a result, the number of effective collisions increases. Thus, rate of reaction increases with increasing concentration.*

- b) *When the temperature is increased, the reacting particles have more energy and move faster. They collide more frequently and with energy greater than the activation energy. This increases the number of effective collisions. Thus, rate of reaction increases when the temperature is increased.*

6. Explain why decreasing the particle size of the reactants increases the rate of reaction.

*When the particle size is decreased, there is an increased surface area exposed to more collision with other particles. Thus, the number of collisions and effective collisions between reacting*

particles increase. This increases the rate of reaction.

7. Explain why using a catalyst increases the rate of reaction.

*Ans: The use of a catalyst decreases the activation energy of the reaction. As a result, there are more reacting particles with energy greater than the activation energy. Thus, the frequency of effective collisions increase. This increases the rate of reaction.*

8. State whether addition of a catalyst increases the amount of energy released during a chemical reaction.

*Ans: Catalyst does not alter the enthalpy change of a chemical reaction.*

9. Describe briefly how the rate of the below reactions could be monitored:

(a) Calcium carbonate with hydrochloric acid.

*Carbon dioxide is produced during the reaction. The mass of the reacting mixture could be monitored during the reaction. As carbon dioxide is released during the reaction, the mass of the reacting mixture would decrease. By*

*monitoring the change in mass of the reacting mixture, the rate of reaction could be monitored.*

(b) Sodium thiosulphate reacts with hydrochloric acid producing sodium chloride, water, sulphur dioxide and sulphur.

*Ans: Sulphur is produced during the reaction and this could produce a suspension which could make the flask opaque when view from the top. By monitoring the time taken for the view to be blocked obscured, the rate of reaction is monitored.*

(c) Decomposition of hydrogen peroxide producing water and oxygen gas.

*Ans: As oxygen gas is produced during the reaction; the reaction could be monitored by measuring the volume of gas that is released.*

10. Give two examples of catalysts and their uses in industry.

*Ans:*

*Iron - is used in the production of ammonia in the Haber process*

*Nickel - is used in the addition reaction of alkene producing alkane.*

## Extended and remedial exercises

Remedial activities for slow learners	Extended activities for gifted and talented learners
<ol style="list-style-type: none"> <li>1. Collecting, cleaning and arranging apparatus and reagents in the laboratory.</li> <li>2. Collect various materials and objects at home for experiments.</li> <li>3. Drawing diagrams from charts on their notebooks</li> </ol>	<ol style="list-style-type: none"> <li>1. Do further research using textbooks or from the internet about rates of reaction. Write short notes then share with other class members.</li> <li>2. Set up experimental apparatus for practicals in the laboratory.</li> <li>3. Come up with a project and make a device for making dirty water clean and soft. Use locally available materials and make the item.</li> </ol>
<p><b>Low order thinking (LOT) questions for slow learners</b></p> <ol style="list-style-type: none"> <li>1. There are four main factors that affect the rate of reaction. These are:             <ol style="list-style-type: none"> <li>i) C ____ This is a measure of how crowded the particles are in a solution and the frequencies of c ____</li> <li>ii) S ____ a ____ This is a measure of how much solid is exposed to reaction collisions.</li> <li>iii) T ____ This affects the energy of the particles and how quickly they c ____ . It also affects the f ____ with which the particles collide and how e ____ the collisions are. The minimum energy required for any reaction to take place is called the ____ energy for that reaction.</li> </ol> </li> </ol> <p><b>Answers to LOT questions</b></p> <p>(i) Concentration, collision</p> <p>(ii) Surface area</p> <p>(iii) Temperature, collide, force, energetic, activation.</p>	<p><b>High order thinking (HOT) questions for gifted learners</b></p> <ol style="list-style-type: none"> <li>1. Explain why increasing the concentration of reacting particles increases the rate of reaction.</li> <li>2. Explain why decreasing the particle size of the reactants increases the rate of reaction.</li> <li>3. State whether addition of catalyst increases the amount of energy release during a chemical reaction.</li> <li>4. Give two examples of catalysts and their uses in industry</li> </ol> <p><b>Answers to HOT questions</b></p> <ol style="list-style-type: none"> <li>1. The more the particles, the more the rate of collision hence, reaction rate increases.</li> <li>2. Decreasing particle size increases the surface area thus, increase in reaction rate.</li> <li>3. Catalyst does not take part in a chemical reaction.</li> <li>4. Iron in the Haber process and vanadium (V) oxide in contact process.</li> </ol>



## Refer to Learner's Book

### Key Unit Competency

After studying this unit, the learners should be able to prepare and carry out reactions of acids and bases with other substances.

### Learning objectives

Competency based curriculum embraces three categories of learning objectives, that is, knowledge and understanding, skills acquisition and attitude and values.

At the end of this unit, learners should have knowledge and understanding on chemical properties of acids and bases and acquire observation, prediction, prepare and handle acids and bases and develop scientific reporting skills. They should have a positive attitude in developing culture of team work, orderliness and appreciate the potential dangers associated with strong acids on biological processes.

**Table 6.1: Knowledge and understanding, skills and attitudes and values to be attained**

Knowledge and understanding	Skills	Attitudes and values
<ul style="list-style-type: none"> <li><input type="checkbox"/> Explain chemical properties of acids and bases.</li> </ul>	<ul style="list-style-type: none"> <li><input type="checkbox"/> Observation skills in experiments that involve changes of colour or evolution of gases.</li> <li><input type="checkbox"/> Develop scientific reporting skills.</li> <li><input type="checkbox"/> Prepare &amp; handle acids and bases.</li> <li><input type="checkbox"/> Predict the products of the reactions of acids and bases with other substances.</li> </ul>	<ul style="list-style-type: none"> <li><input type="checkbox"/> Develop a culture of working in a team.</li> <li><input type="checkbox"/> Develop orderliness especially when performing experiments.</li> <li><input type="checkbox"/> Appreciate the potential dangers associated with strong acids and bases.</li> <li><input type="checkbox"/> Appreciate the uses of acids of biological processes especially in digestion of proteins in human beings and other organisms.</li> <li><input type="checkbox"/> Appreciate the uses of base in balancing the pH of soil.</li> </ul>

## **Pre-requisite to the unit**

Learners have interacted with substances containing acid and bases in their daily lives. From the food we eat to products we use at home. All these substances used contain acids and bases. We have to therefore understand their properties in order to prevent poisoning or harming ourselves and the environment.

In this unit you will teach learners about chemical properties of acids and bases. They will learn how to prepare acid and bases and carry out their reactions with other substances.

## **Links to other subjects**

During this lesson, strive to emphasise the use of hydrochloric acids secreted in the gastric juice during digestion of proteins and maintenance of blood pH in Biology. The determination of acidity and alkalinity of soil in Agriculture.

## **Background information**

Chemical properties of acids and bases are very important in the life of human beings and animals in general. Indigestion in the human stomach, digestion of proteins and anti-acids all involve aspects of acids and bases. This topic will help learners understand how acids and bases affect the human body and the soil and how any adverse effects of these can be mitigated. Also in this topic environmental issues of acids is discussed.

## **Cross-cutting issues to be addressed**

### **1. Inclusive learning**

Demonstrate this by intergrating learners of all abilities and of different gender and those with special needs during formation of groups.

Discourage any form of discrimination during class time and encourage learners to practice this even outside class.

### **2. Gender education**

Both boys and girls should participate equally in all activities. Emphasise to learners that anybody irrespective of their gender can pursue a career in any field of chemistry. Give examples of role models who are successful in their careers locally.

### **3. Financial education**

Emphasise the need to follow instructions, handle apparatus carefully in order to minimise breakage and use reagents in specified quantities to limit wastage. All these have financial implications in terms of cost.

### **4. Standardisation culture**

Emphasise the need to use chemicals and apparatus certified by the Rwanda Standards Board (RSB).

## 5. Environment and sustainability education

Bring to the attention of learners the fact that most acids and bases have harmful effects in the environment. Learners should be aware of this and take caution when handling chemicals of any nature.

## 6. Health education

Emphasise to learners that some acids and bases are harmful when exposed to the skin. They should be extra careful when handling strong and concentrated acids and bases.

### Generic competencies

#### 1. Research skills

Guide learners on how to find information regarding various topics, on how to come up with summarised notes from a large body of text and on how to do internet searches for the various content areas they are looking for.

#### 2. Communication in English

Communication in English will be improved when learners freely participate in the discussions and presentations. Encourage all learners irrespective of their abilities to participate in group discussions, during presentations by asking questions and during question and answer sessions to either introduce or wrap up the lessons.

#### 3. Cooperation and interpersonal management and life skills

During group discussions and pair-work let learners engage one another by

giving a chance for all to participate. Also, during group presentations, you can allow rotational presentations within the group members. Gifted learners should help in coming up with presentation content as slow learners contribute.

**Note:** You should allow progressive gradually learners to do presentations as well and correct them where they go wrong. Advise learners to appreciate the different abilities of their group members and accommodate each other's views.

#### 4. Critical thinking and problem solving skills

This competence will be developed by learners as they answer the probing questions at the beginning of this unit and as they discuss the results of the various practical activities. Guide learners to discover for themselves chemical properties of acids and bases. This competence will also come about as learners think about their findings in the activities and as they give out their suggestions.

#### Key words in this unit and their meanings

- **Antacids** – substances that neutralise the acid made by the stomach.
- **Indicator** – any substance that gives a visible sign, usually by a colour change is a chemical reaction.
- **Neutralisation** – a chemical reaction in which an acid and a base interact leading to formation of a salt and water.

### Guidance on the problem statement

In this topic, you will teach about chemical properties of acids and bases. As a way of introducing these concepts, refer learners to the pictures on of Learner's Book. The pictures show various products that contain acids and bases. Allow learners in groups to discuss the products.

Guide the learners to discover what they will learn in this topic. Further, emphasise the need for taking this topic seriously in the course of the lessons as it can lead to environmental awareness.

The groups should be constituted based on learners abilities and class size. Let them give answers to the probing questions associated with the picture.

### Attention to special educational needs

Support for multi ability learning	Support for special needs learning
<ul style="list-style-type: none"><li><input type="checkbox"/> Gifted learners to carry out research on reaction of acids and bases.</li><li><input type="checkbox"/> Both gifted and progressive gradually learners to be given equal opportunity to lead in group discussions and to do presentations of group findings to the rest of the class.</li><li><input type="checkbox"/> Ensure all learners respect other's views irrespective of their shortcomings or talents.</li></ul>	<ul style="list-style-type: none"><li><input type="checkbox"/> Provide braille for visually impaired learners and large print text to learners with seeing difficulties. Provide sign language alphabet symbols and sign language interpreters for the deaf.</li><li><input type="checkbox"/> Also, arrange learners such that shortsighted ones are at the front and long-sighted ones are at the back. Spectacles can as well be provided if available for learners with seeing difficulties.</li></ul>

### List of lessons

Lesson Number	Lesson title	No. of periods
1	Preparation of acids and bases	3
2	Reactions of acids and bases	3
3	Uses and dangers of acids and bases	1
4	End of unit assesment test	1

## 6.1: Preparation of acids and bases

Refer to Learner's Book

### Lesson 1: Preparation of acids and bases (To be covered in three periods)

#### Specific objectives

By end of the lesson, learners should be able to prepare acids and bases.

#### Preparation for the lesson

1. This lesson will be taught in three periods and will involve experiments and group work. The learners should be organised in class and laboratory in a way that suits experiments, discussion, and presentations.
2. Bring charts on the preparation of acids and bases and textbooks for reference in class.

#### Suggested teaching aids

- Textbooks, charts on preparation of acids and bases.
- Chalkboard diagrams
- Dictionary
- Internet

#### Pre-requisite to the lesson

Introduce the unit and lesson as explained under the guidance above then narrow down to this lesson.

#### Suggested teaching and learning activities

1. You may begin the lesson by asking learners probing questions about what they know about acids and bases, where they are found in nature and their uses.
2. Organise learners into convenient groups according to the resources available, for Activities 6.1, 6.2 and 6.3 in the Learner's Book respectively.
3. Provide them with the apparatus and reagents required. Let them carry out the activity as outlined in the procedures.
4. Ask each group to present its findings. Use their findings to explain preparation of acid by displacing a volatile acid by a less volatile one as outlined in the Learner's Book as they take notes.
5. Thereafter, discuss with learners preparation of a base by addition of water to soluble metal oxide and by addition of water to a metal as outlined in the Learner's Book .
6. Use charts, diagrams and equations to illustrate this reactions during the preparations.
7. Let learners appreciate the need to respect procedure during practical activities and essence of team work in group activities.

8. At this point you can give a summary of preparation of acids and bases.
9. Instruct learners to attempt questions in Self-evaluation Tests 6.1 and 6.2 in the Learner's book respectively.

### Synthesis

This lesson introduces learners to preparation of acid and bases. The activities carried out during the lesson will help learners appreciate the significance and importance of acid and bases.

### Suggested lesson assessment

Assess whether the learning objectives of the lesson are being achieved by asking the following questions:

1. Give the difference between an acid and a base.

**Ans:** *An acid is highly corrosive with sour taste while a base have bitter taste with a soapy feel.*

2. How can you prepare a base?

**Ans:** *By adding water to a soluble metal oxide or metal such as sodium or potassium.*

### Answers to Self-evaluation Test

#### 6.1

Refer to Learner's Book

1. a). By reacting sodium chloride with sulphuric acid and dissolving hydrogen chloride gas produced in water.

Refer to learner's book .

- b. i. Displacement reaction  
ii. Nitric acid–It has a low boiling point.

2. By dissolving sodium oxide in water.  
Refer to Learner's Book

### Answers to Self-evaluation Test

#### 6.2

Refer to Learner's Book

1. Immersed in organic solvent e.g paraffin to prevent reaction with oxygen or water vapour present in the air.
2. When a small piece sodium metal is dropped in water, it reacts violently darting around with a hissing sound to form sodium hydroxide and hydrogen gas.
3.  $2\text{Na(s)} + 2\text{H}_2\text{O(l)} \rightarrow 2\text{NaOH(aq)} + \text{H}_2\text{(g)}$
4. Introducing a burning splint to the mouth of the gas jar. It burns with a 'pop' sound.

### 6.2: Reactions of acids and bases

Refer to Learner's Book

#### Lesson 2: Reactions of acids and bases (To be covered in three periods)

#### Specific objectives

By end of the lesson, learners should be able to describe the reactions of acids and bases.

## Preparation for the lesson

1. This lesson will be taught in three periods and will involve experiments, group work, research work and note taking. The learners should be organised in class and laboratory in a way that suits experiments, discussion, research work and presentations.
2. Bring charts on reactions of acids and bases and textbooks for reference in class.
3. Collect materials required for the experiment in advance.

## Suggested teaching aids

- Textbooks, charts on reaction of acids and bases.
- Internet

## Pre-requisite to the lesson

From previous lessons, learners are aware of experimental procedures and the need to follow them carefully. This is important to get learners the desired outcome. In this lesson, learners will learn how to prepare acids and bases.

## Suggested teaching and learning activities

1. You may begin the lesson by reminding learners the reactions they know involving acids and bases. They have come across many reactions before involving the same.
2. Organise learners into convenient groups according to the resources available, for activity 6.4 in the Learner's Book . In this activity they

will investigate the reaction of acids.

3. Provide them with the apparatus and reagents required. Let learners carry out the activity following in the procedure. They will discuss their findings in groups, write a report and present it in class.
4. Ask each group to present its findings. Build on their findings to explain the reactions of acids with various substances as outlined in the Learner's Book as they take notes.
5. Thereafter, introduce reactions of bases, use activity 6.5 in the Learner's Book .
6. They will discuss their findings in groups, write a report and present it in class.
7. Use charts, diagrams and equations to illustrate these reactions during the discussions.
8. Let learners appreciate the need to respect procedure during practical activities and the importance of team work in group activities.
9. At this point you can give a summary of reactions of acids and bases.
13. Instruct learners to attempt questions in Self-evaluation Tests 6.3 and 6.4 in the Learner's Book respectively.

## Synthesis

This lesson introduces learners to the reactions of acid and bases. The activities carried out during the lesson will help learners to appreciate the importance of acid and bases in many every day's activities.

### Suggested lesson assessment

Assess whether the learning objectives of the lesson were met by asking the following questions:

What is formed when an acid reacts with a base?

**Ans:** *This is neutralisation reaction resulting in the formation of a salt and water*

### Answers to Self-evaluation Test 6.3

Refer to Learner's Book

- Magnesium chloride + carbon dioxide + water
  - Sodium nitrate + carbon dioxide + water
  - Calcium sulphate + water + carbon dioxide
  - Potassium chloride + water + carbon dioxide
- Salt and water
- $K_2O(s) + 2HCl(aq) \rightarrow 2KCl(aq) + H_2O(l)$
- Ammonium nitrate. See the evaluation below.  
 $HNO_3(aq) + NH_3(g) \rightarrow NH_4NO_3(aq)$

### Answers to Self-evaluation Test 6.4

Refer to Learner's book

- When an acid reacts with a base, salt and water are produced.
  - Acid reacts with carbonates to produce salt, water and carbon dioxide.
  - Acid reacts with bicarbonates to produce salt, water and carbon dioxide.
  - Dilute acids react with most metals to produce salt and hydrogen gas.
- a reaction involving acid and base forming salt and water
  - $CaO(s) + 2HCl(aq) \rightarrow CaCl_2(aq) + H_2O(g)$
- Metal oxides and hydroxides react with acids to form a salt and water.  
Metal carbonates react with acids to form a salt, water and carbon dioxide.
  - $H_2SO_4(aq) + 2KOH(aq) \rightarrow K_2SO_4(aq) + 2H_2O(l)$
- An oxide that can react both as an acid as well as a base.
  - Oxides of copper, zinc, tin, lead and aluminium.

## 6.3 Uses and dangers of acids and bases

### Lesson 3: Uses and dangers of acids and bases (To be covered in one period)

Refer to Learner's Book

#### Specific objectives

By the end of this lesson, learners should be able to explain the uses and dangers of acids and bases.



## Preparation for the lesson

The lesson will be taught in one period. It will involve a discussion among the learners on the uses and dangers of acids and bases and assessing learners' achievements.

## Suggested teaching aids

Charts on uses and dangers of acids and bases.

## Pre-requisite to the lesson

Acids and bases form part of substances we use daily. Ask learners if they recall the dangers and uses of acids & bases.

## Suggested teaching and learning activities

1. Begin the lesson by asking learners probing questions about uses and dangers of acids and bases from their experiences. Let them share with the class.
2. Organise learners into pairs to do Activity 6.6 in Learner's Book. Let them answer the questions as outlined. Tell them to write a report which they will present to the class.
3. Thereafter have a class discussion on the uses and dangers of acid and bases as outlined in the Learner's Book, as they take notes.
4. At this point you can give a summary of uses and dangers of acids and bases.

5. Instruct learners to attempt questions in Self-evaluation Test 6.5 and Test your Competence 6.

## Synthesis

This lesson is about creating awareness to the learners of the uses and dangers of acids and bases. Through the activities and presentation, emphasise the need to be careful when handling acids and bases.

## Suggested lesson assessment

Assess whether the learning objectives of the lesson have been met by using Self-evaluation exercise 6.5.

## Answers to Self-evaluation Test

### 6.5

*Refer to Learner's book*

1. a) Industrial use and digestion in the stomach, use as electrolyte in car battery, pickling of metals.  
b) Manufacture of fertilisers, antacids, cement, soaps and detergents.
2. *Acids* - Cause acid rain  
Vapours from acids can cause damage to eyes  
*Bases* - corrosive

## Summary of the unit

This unit explores chemical properties of acids and bases. Learners are given the opportunity to prepare and describe chemical properties of acids and bases. Learners are also taught on the dangers associated with strong acids and bases. Learners should appreciate the uses of acids and bases in nature.

## Additional information for the teacher

### What is acid or a base?

Arrhenius (Swedish) defined an acid is a material that can release a proton or hydrogen ion ( $H^+$ ). Hydrogen chloride in water solution ionizes and becomes hydrogen ions and chloride ions. If that is the case, a base, or alkali, is a material that can donate a hydroxide ion ( $OH^-$ ). Sodium hydroxide in water solution becomes sodium ions and hydroxide ions. Thomas Lowry (England) and J.N. Brønsted (Denmark) working independently in 1923 established and defined, an acid is a material that donates a proton and a base is a material that can accept a proton.

The Lowry- Brønsted definition is broader, including some ideas that might not initially seem to be acid and base types of interaction. Every ion dissociation that involves a hydrogen or hydroxide ion could be considered an acid- base reaction. Just as with the Arrhenius definition, all the familiar materials we call acids are also acids in the Lowry - Brønsted model.

The G.N. Lewis (1923) idea of acids and bases is even broader than the Lowry - Brønsted model. The Lewis definitions are: Acids are electron pair acceptors and bases are electron pair donors.

#### a. Properties of acids

For the properties of acids and bases we will use the Arrhenius definitions.

- Acids release a hydrogen ion into

water (aqueous) solution.

- Acids neutralise bases in a neutralisation reaction. An acid and a base combine to make a salt and water. A salt is any ionic compound that could be made with the anion of an acid and the cation of a base. The hydrogen ion of the acid and the hydroxide ion of the base unite to form water.
- Acids corrode active metals. Even gold, the least active metal, is attacked by an acid, When an acid reacts with a metal, it produces a compound with the cation of the metal and the anion of the acid and hydrogen gas.
- Acids turn blue litmus to red. Litmus is one of a large number of organic compounds that change colors when a solution changes acidity at a particular point. Litmus is the oldest known pH indicator. It is red in acid and blue in base. The phrase, 'litmus test,' indicates that litmus has been around a long time in the English language. Litmus does not change colour exactly at the neutral point between acid and base, but very close to it. Litmus is often impregnated onto paper to make 'litmus paper.'
- Acids taste sour.

#### b. Properties of bases

- Bases release a hydroxide ion into water solution. (Or, in the Lowry - Brønsted model, cause a hydroxide ion to be released into water solution by accepting a hydrogen ion in water.)

- Bases neutralise acids in a neutralisation reaction. The word - reaction is: Acid plus base makes water plus a salt. Where 'Y' is the anion of acid 'HY,' and 'X' is the cation of base 'XOH,' and 'XY' is the salt in the product, the reaction is:
- $\text{HY} + \text{XOH} \rightarrow \text{HOH} + \text{XY}$
- Bases denature protein. This accounts for the "slippery" feeling on hands when exposed to base. Strong bases that dissolve in water well, such as sodium or potassium hydroxide are very dangerous because a great amount of the structural material of human beings is made of protein. Serious damage to flesh can be avoided by careful use of strong bases.
- Bases turn red litmus to blue. This is not to say that litmus is the only acid - base indicator, but that it is likely the oldest one.
- Bases taste bitter. There are very few food materials that are alkaline and taste bitter. It is even more important that care be taken in tasting bases.

### Strong acids and strong bases

The common acids that are almost one hundred percent ionized are:

- $\text{HNO}_3$  - nitric acid
- $\text{HCl}$  - hydrochloric acid
- $\text{H}_2\text{SO}_4$  - sulphuric acid
- $\text{HClO}_4$  - perchloric acid
- $\text{HBr}$  - hydrobromic acid
- $\text{HI}$  - hydroiodic acid

The acids on this short list are called strong acids, because the amount of acid quality of a solution depends upon the concentration of ionized hydrogens.

Other acids are incompletely ionized, existing mostly as the unionized form. Incompletely ionized acids are called weak acids, because there is a smaller concentration of ionized hydrogens available in the solution. Do not confuse this terminology with the concentration of acids. The differences in concentration of the entire acid will be termed dilute or concentrated.

In the list of strong acids, sulphuric acid is the only one that is diprotic, because it has two ionizable hydrogens per formula (or two mols of ionizable hydrogen per mol of acid). (Sulphuric acid ionizes in two steps. The first time a hydrogen ion splits off of the sulfuric acid, it acts like a strong acid. The second time a hydrogen splits away from the sulphate ion, it acts like a weak acid.) The other acids in the list are monoprotic, having only one ionizable proton per formula. Phosphoric acid,  $\text{H}_3\text{PO}_4$ , is a weak acid. Phosphoric acid has three hydrogen ions available to ionize and lose as a proton, and so phosphoric acid is triprotic. We call any acid with two or more ionizable hydrogens polyprotic.

Likewise, there is a short list of strong bases, ones that completely ionize into hydroxide ions and a conjugate acid. All of the bases of Group I and Group II metals except for beryllium are strong bases. Again, like the strong acids, the

strong bases are completely ionized in water solution. Lithium, rubidium and cesium hydroxides are not often used in the lab because they are expensive.

The bases of Group II metals, magnesium, calcium, barium, and strontium are strong, but all of these bases have somewhat limited solubility. Barium hydroxide has a high enough solubility to really call it the only dibasic strong base. Magnesium hydroxide has a particularly small solubility. Potassium and sodium hydroxides both have the common name of lye. Soda lye (NaOH) and potash lye (KOH) are common names to distinguish the two compounds.

The bases of Group I metals are all monobasic. The bases of Group II metals are all dibasic. Aluminum hydroxide,  $\text{Al}(\text{OH})_3$  is tribasic. Any material with two or more ionizable hydroxyl groups would be called polybasic.

Most of the alkaline organic compounds (and some inorganic materials) have an amino group  $-(\text{NH}_2)$  rather than an ionizable hydroxyl group. The amino group attracts a proton (hydrogen ion) to become  $-(\text{NH}_3)^+$ . (The dash before the  $-(\text{NH}_3)^+$  or  $(\text{NH}_2)$  indicates a single bonding electron, so this is attached to something else by a covalent bond.) By the Lowry- Brønsted definition, an amino group definitely acts as a base, and the effect of removing hydrogen ions from water molecules is the same as adding hydroxide ions to the solution.

## End of unit assessment

This section is divided into two parts:

- Answers to Test your Competence 6
- Additional exercises for unit assessment (consolidation exercises)

### (a) Answers to Test your Competence 6

Refer to Learner's book

1. a. Displacing a volatile acid by a less volatile one.  
b. i. Refer to Learner's Book fig 6.2.  
ii.  $\text{NaCl}(\text{s}) + \text{H}_2\text{SO}_4(\text{l}) \rightarrow \text{NaHSO}_4(\text{s}) + \text{HCl}(\text{g})$   
iii. Potassium chloride  
c. i. Bubbles of gas produced or effervescence occurs. The gas is hydrogen.  
ii. Introduction of a burning splint that burns with a 'pop' sound.  
iii.  $\text{Zn}(\text{s}) + 2\text{HCl}(\text{aq}) \rightarrow \text{ZnCl}_2(\text{aq}) + \text{H}_2(\text{g})$
2. (a) i. Sodium oxide dissolved  
ii. Sodium hydroxide  
iii.  $\text{Na}_2\text{O}(\text{aq}) + \text{H}_2\text{O}(\text{l}) \rightarrow 2\text{NaOH}(\text{aq})$   
(b) i. Neutralisation  
ii. In acid, methyl orange indicator is reddish and in alkali, it is yellow.  
(iii)  $\text{NaOH}(\text{aq}) + \text{HCl}(\text{aq}) \rightarrow \text{NaCl}(\text{aq}) + \text{H}_2\text{O}(\text{l})$

3. i. The sodium reacts with water and begins to melt. The hydrogen produced self-ignites and burns with a bright flame.
- ii.  $2\text{Na(s)} + 2\text{H}_2\text{O(l)} \rightarrow 2\text{NaOH(aq)} + \text{H}_2\text{(g)}$
- iii.  $\text{PbO(s)} + 2\text{NaOH(aq)} \rightarrow \text{Na}_2\text{PbO}_2\text{(aq)} + \text{H}_2\text{O(l)}$
4. a). It is the rain water contaminated by the acidic gases released into the atmosphere which pollutes the environment.
- b). Acid rain is caused by a chemical reaction that begins when compounds like sulphur dioxide and nitrogen oxides are released into the air. These substances can rise very high into the atmosphere, where they mix and react with water vapour, oxygen, and other chemicals to form more acidic pollutants, known as acid rain.
- c). Destroy plants and corrodes buildings
5. Crossword puzzle
6. The reactions start and then soon stops. This is due to formation of insoluble coat or layers of lead chloride that prevents further reaction.
- $\text{PbO} + 2\text{HCl(aq)} \rightarrow \text{PbCl}_2\text{(s)} + \text{H}_2\text{O(l)}$
7. a). Antacid, addition of flavour to drugs.
- b). Strong chemical base in the manufacture of pulp and paper, textiles, drinking water, soaps and detergents and as a drain cleaner.
8. a). Kill germs and provide an environment for activity of proteases.
- b). i. Discomfort or pain in the upper abdomen—a group of symptoms which often include bloating, nausea and burping.
- ii. Eating too much food, eating quickly without chewing properly.
- iii. Eating just enough food, using antacid drugs.

**Across**

1. Base
2. Hydrochloric acid
3. Carbonic acid
4. Citric
5. Litmus solution
6. Vinegar

**Down**

7. Sulphuric acid
8. Caustic

9. A

10. Acid

11. Neutralisation

## b) Additional end unit assessment exercise

### (Consolidation exercise)

1. Use the words below to fill the gaps in the paragraph below.

*acidic, alkaline, bases, colour, basic, dissolve, dissolves, filtered, seven, zero, indicator, neutral, neutralise, nitric oxides, pH scale, salt, water*

When a substance dissolves in water it forms an aqueous solution, the solution may be acidic, i) \_\_\_\_\_ or neutral. Pure water itself is ii) \_\_\_\_\_. An iii) \_\_\_\_\_ can be used to show acidic or alkaline a solution is by the way the iv) \_\_\_\_\_ changes. The v) \_\_\_\_\_ is used to show numerically how acidic or alkaline a solution is. If the pH is vi) \_\_\_\_\_ the solution is neutral, if the pH is over 7 it is vii) \_\_\_\_\_ and if it is less than 7 it is viii) \_\_\_\_\_.

Ans:

- i) *basic* ii) *neutral*      iii) *indicator*  
iv) *colour* v) *pH scale*    vi) *Seven*  
vii) *alkaline* viii) *acidic*

2. A carbonate mineral rock was tested with dilute sulphuric acid and bubbles formed. The gas formed was \_\_\_\_\_.

Ans: *Carbon dioxide*

3. Which two reactants would you use to make potassium nitrate?

- A. Nitric acid and potassium hydroxide  
B. Nitric acid and sodium hydroxide  
C. Sulphuric acid and sodium nitrate  
D. Sodium nitrate and potassium chloride

Ans: A

4. Insoluble bases and metals will not dissolve to form an alkaline solution, but they will dissolve in acids to form transition metal salts. What pair of

chemicals will make cobalt chloride and hydrogen?

- A. Cobalt hydroxide + sodium chloride  
B. Cobalt oxide + sulphuric acid  
C. Cobalt hydroxide + nitric acid  
D. Cobalt + hydrochloric acid

Ans: D

5. a) Salt compounds of alkali metals can be made by reacting solutions of their hydroxides with acids. These are \_\_\_\_\_ types of reactions.

Ans: *Neutralisation*

b) The particular salt produced in any reaction between an acid and an alkali depends on the type of acid used and the metal. Neutralising using hydrochloric acid produces a \_\_\_\_\_ salt, nitric acid \_\_\_\_\_ salt while sulphuric acid \_\_\_\_\_ salt.

Ans: *chloride, nitrate, sulphate*

6. Given the following neutralization equation:

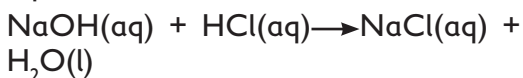

Which is the alkali? \_\_\_\_\_

Ans: *NaOH*

7. Ammonia dissolves in water to produce a \_\_\_\_\_ solution. This solution can be neutralized with acids to produce a \_\_\_\_\_ which is neutral in nature.

Ans: *Basic, salt*

8. Dilute sulphuric acid will not readily react with one of the following. Which one?

- A. Magnesium oxide  
B. Copper  
C. Ammonia  
D. Zinc carbonate

Ans: B

## Extended and remedial exercises

Remedial activities for slow learners	Extended activities for gifted and talented learners
<ol style="list-style-type: none"><li>1. Collecting, cleaning and arranging apparatus and reagents in the laboratory.</li><li>2. Collect various materials and objects at home for experiments.</li><li>3. Drawing diagrams from charts on their notebooks</li></ol>	<ol style="list-style-type: none"><li>1. Do further research in textbooks or the internet about reactions between weak acids and weak bases and investigates areas of useful application in life. Write short notes then share with other class members.</li><li>2. Set up experimental apparatus for practicals in the laboratory.</li><li>3. Come up with a project for recycling substances made from acid and bases. Use locally available materials and make the item.</li></ol>
<b>Low order thinking (LOT) questions for slow learners</b>	<b>High order thinking (HOT) questions for gifted learners</b>
<ol style="list-style-type: none"><li>1. How would you prepare hydrochloric acid in the laboratory?</li><li>2. The reaction between acid and a base forms.</li><li>3. What are the uses of a base?</li></ol>	<ol style="list-style-type: none"><li>1. Differentiate between a strong acid and a weak acid.</li><li>2. When performing a reaction involving sodium metal, a pea sized portion is used. Give a reason.</li><li>3. How can the dangers posed by acids and bases be reduced?</li></ol>
<b>Answers Low order thinking questions</b>	<b>Answers to high order thinking questions</b>
<ol style="list-style-type: none"><li>1. By reacting sodium chloride with conc. sulphuric acid.</li><li>2. Salt and water.</li><li>3. Fertilisers, antacids, cement</li></ol>	<ol style="list-style-type: none"><li>1. A strong acid ionizes completely while a weak acid ionizes partially in aqueous solution.</li><li>2. Sodium metal reacts explosively with water.</li></ol> <p><i>Acids</i> - using catalytic convertors or in industries and car exhaust systems.</p> <p><i>Bases</i> - Reducing on usage or using alternatives with lesser adverse effects.</p>

**Refer to Learner's Book**
**Key unit competency**

After studying this unit, learners should be able to determine the concentrations of solutions from data obtained by simple acid-base titration.

**Learning objectives**

Competency based curriculum embraces three categories of learning objectives,

that is, knowledge and understanding, skills acquisition and attitude and values. At the end of the unit, learners should have knowledge and understanding of concentration of solutions and have the right attitude, self-confidence and development of team work.

**Table 7.1 Knowledge, skills and values to be attained**

Knowledge and understanding	Skills	Attitudes and values
<ul style="list-style-type: none"> <li><input type="checkbox"/> Explain the difference between end point and equivalence point.</li> <li><input type="checkbox"/> Describe the process of titration.</li> </ul>	<ul style="list-style-type: none"> <li><input type="checkbox"/> Carry out experiments in groups to prepare solutions of different concentrations.</li> <li><input type="checkbox"/> Perform simple acid-base titrations.</li> <li><input type="checkbox"/> Use data obtained from the titration of an acid and base to calculate the concentration of either acid or base.</li> </ul>	<ul style="list-style-type: none"> <li><input type="checkbox"/> Develop a culture of working in a team.</li> <li><input type="checkbox"/> Develop self-confidence during presentations and discussion in groups.</li> <li><input type="checkbox"/> Appreciate the importance of accuracy in measurement.</li> <li><input type="checkbox"/> Appreciate the importance of repeating procedures to obtain more accurate results</li> </ul>

**Pre-requisite to the unit**

Learners have already learnt about chemical properties of acids and bases in unit 6. The knowledge they acquired will help them in better understanding of

this unit. Learners also have encountered situations involving solutions and their concentrations, for example preparing tea and adding salt to food.



The learners have come across and even performed experiments involving use of dilute acids and concentrated acids.

Review with learners all these knowledge areas as you prepare them for simple acid-base titrations.

### **Links to other subjects**

During the lessons, strive to bring to the awareness of learners the fact that this topic is related to mole concept that will be studied chemistry at a higher level. Let them understand that at this level, they may only need the basic information. Later in life when they specialise in medicine and particularly pharmacology, for example, preparation of oral rehydration salts will require this knowledge.

### **Background Information**

Titration is the technique of determining the concentration of a solution by reacting volumes. Two or three different volumes of different reactants are made to react to an end point, which is normally shown by means of an indicator. This technique falls under the study of volumetric analysis or largely known as quantitative analysis.

At ordinary level learners are basically exposed to volumetric analysis involving acid-base reactions, that is neutralisation reactions only (remember the acids and bases were introduced in S1 chemistry)

### **Cross-cutting issues to be addressed**

#### **1. Inclusive learning**

All categories of learners should be

encouraged to participate during lessons and practical experiments. Make arrangement to take care of learners with special needs. In particular learners with visual impairment should be placed in front of the classroom. Provide braille for learners with visual impairment and large print text for those with sight problems.

Group physically challenged learners with others to assist them during movement and field trips and other practical activities. Furthermore, give these learners tasks they can manage comfortably during practicals.

#### **2. Gender education**

Both boys and girls should participate equally in all activities. Emphasise to learners that anybody irrespective of their gender can pursue a career in this chemistry field. Give examples of role models who are successful in their careers locally.

#### **3. Standardisation culture**

Emphasise the need to use chemicals and apparatus certified by the Rwanda Board Standards.

#### **4. Peace and values education**

Emphasise to learners the importance of working harmoniously with each other during group work and class activities.

#### **5. Health education**

Emphasise to learners that some chemicals they will handle during the experiments are dangerous and they should handle them with care.

## Generic competencies

### 1. Research skills

Guide learners on how to find information regarding various topics, on how to come up with summarised notes from a large body of text and on how to do internet searches for the various content areas they are looking for.

### 2. Communication in English

Communication in English will be improved when learners freely participate in the discussions and presentations. Encourage all learners irrespective of their abilities to participate in group discussions, during presentations by asking questions and during question and answer sessions to either introduce or wrap up the lessons.

### 3. Cooperation and interpersonal management and life skills

During group discussions and pair-work let learners engage one another by giving a chance for all to participate. Also, during group presentations, you can allow rotational presentations within the group members. Gifted learners should help in coming up with presentation content as slow learners contribute.

**Note:** You should allow slow learners to do presentations as well and correct them where they go wrong. Advise learners to appreciate the different abilities of their group members and accommodate each other's views.

### 4. Critical thinking and problem solving skills

This competence will be developed by learners as they answer the probing questions at the beginning of this unit and as they discuss the results of the various practical activities. Guide learners to discover for themselves concentrations of solutions. This competence will also come about as learners think about their findings in the activities and as they give out their suggestions.

### 5. Lifelong learning skills

Good environmental management and realising the importance of natural resources builds the economy of a country.

#### Key words in this unit and their meanings

- **Acid–base titration** – the determination of the concentration of an acid or base by exactly neutralising the acid or base with an acid or base of known concentration.
- **Equivalence point** – the point in a titration where the amount of titrant added is enough to completely neutralize the analyte solution.
- **End point** – the point in a titration at which a reaction is complete, often marked by a colour change.
- **Dilution** – the action of making a liquid more dilute.
- **Standard solution** – a solution whose concentration is known.
- **Concentration** – in industry and consumer world, the most common method of expressing concentration

is based on quantity of solute in a fixed quantity of solution.

- **Percent composition (by mass or by weight)** – parts of solute per 100 parts of solution or the fraction of solute in a solution multiplied by 100.
- **Molarity** – the number of moles of solute in exactly one litre of solution.
- **Mole fraction** – the mole fraction of a component in a solution is the ratio of the number of moles of that component to the total number of moles of all components in the solution.
- **Volume percent** – the ratio of solute in a solution multiplied by 100. Often used when preparing solutions of liquids.

### **Guidance on the brain teaser**

This topic is about the concentration of solutions and its importance in the body and in everyday life. Introduce the topic by asking learners why they feel thirsty?

This is due to imbalance of salt concentration in the body.

As a way of introducing these concepts, refer learners to the pictures in Learner's Book. The pictures show a flow diagram in the manufacture of table salt in the laboratory. Allow learners in groups to discuss the stages. The groups should be constituted based on learner abilities and class size. Let them give answers to the probing questions associated with the picture.

Guide the learners to discover what they will learn in this topic. Further, emphasise the need for taking this topic seriously in the course of the lessons as it is a required foundation for careers such as medicine or pharmacy among other courses.

## Attention to special educational needs

Support for multi ability learning	Support for special needs learning
<ul style="list-style-type: none"><li><input type="checkbox"/> Gifted learners to carry out acid-base titrations and assist the progressive gradual learners on how to go about it.</li><li><input type="checkbox"/> Progressive gradual learners will assist with arrangement of apparatus and recording of experimental observations.</li></ul>	<ul style="list-style-type: none"><li><input type="checkbox"/> Group learners with different learning abilities together. This will enable them to collaborate and learn from their experience. They will help each other by working together to complete tasks</li></ul>

### List of lessons

Lesson Number	Lesson title	No. of periods
1	Concept of concentration	3
2	Preparation of solutions	4
3	Acid – base titration	6
4	End of unit assessment	2

## 7.1 Concept of concentration

Refer to Learner's Book

Lesson 1: The concept of concentration using mass, molarity, mole fraction and volume percentage (To be covered in three periods)

### Specific objectives

By the end of the lesson, learners should be able to :

- Explain the concept of concentration.
- Explain the concept of concentration using volume percentage by performing calculations of concentration expression in terms of volume.
- Do calculations involving the mole fraction to express concentration of solutions.

- Do calculation of concentration in terms of molarity.
- Do calculations involving mass percentage to express concentration of solutions.

### Preparation for the lesson

1. The lesson will be taught in three periods. It will involve mainly activities performed by learners, prepare to engage learners in a discussion regarding the tasks they are doing and assessing learners' achievements. The learners should be organised in the class in a way that will encourage the teaching methods suggested.
2. You should carry out pilot experiments, in advance.

### **Suggested teaching aids**

- Provide exercises to different groups and present to the whole class at the blackboard.
- A chart containing the relationship between molarity, mass and relative molecular mass.
- You may come up with your own examples of calculations charts on manila papers if your school does not have charts.

### **Pre-requisite to the lesson**

Introduce the unit as explained under guidance on the brain teaser section above then narrow down to this lesson.

### **Suggested teaching and learning activities.**

1. Ask probing questions to introduce the lesson. Such questions may include:
  - Assuming you visited your friend and you are offered a cup of tea with sugar already added. Without informing you that sugar was added, you add more sugar to the tea. What would the taste of your tea? More or less concentrated?
  - Mention how can concentration be expressed?
2. From their answers introduce the concept of concentration and how they are expressed.
3. Inform learners that there are units of concentration and guide them how are express them. You

will tackle each of the four ways of expressing concentrations. As outlined in the Learner's Book.

### **A. The concept of concentration using percentage composition by mass**

4. Discuss with learners on how to express concentration using percentage composition as outlined in the Learner's Book.
5. Use the examples suggested to show them how to express percentage composition by mass.
6. Give learners extra activities on this to practice.

### **B. The concept of concentration using molarity**

7. Introduce molarity as a way of expressing concentration.
8. Discuss with learners on how to express concentration using molarity as outlined in the Learner's Book.
9. Use the examples suggested to show them how to express molarity.
10. Give learners extra activities on this to practice.

### **C. The concept of concentration using volume percentage**

11. Introduce volume percentage as a way of expressing concentration.
12. Discuss with learner on how to express concentration using volume percentage as outlined in the Learner's Book.

13. Use the examples suggested to show them how to express percentage volume.
14. Give learners extra activities on this to practice.
15. At this point you can give a summary of how concentrations are expressed.
16. End the lesson by instructing learners to attempt questions in Self-evaluation Tests 7.1

### Synthesis

The lesson introduces learners to the concept of concentration. The activities carried out during the lesson should help learners to visualise the importance of knowing concentrations in everyday life.

### Suggested lesson assessment

1. Assess whether the learning objectives of the lesson were met by asking questions such as:
  - a. What did you learn in this lesson?
  - b. What are some of the processes that take place in human body?
  - c. What is the purpose of concentration in everyday life?
  - d. Suppose we lacked the knowledge of concentration, what would happen?
2. Guide learners to answer assessment questions provided.
3. Summarise the lesson by providing individual-based exercises and learners should submit their work to the teacher.

## Answers to Self-evaluation Test 7.1

Refer to Learner's Book

$$1. \text{ If } 100 \text{ cm}^3 \text{ contains } 0.91 \text{ g of NaCl}$$

$$1000 \text{ cm}^3 \text{ contain } \frac{1000 \text{ cm}^3 \times 0.91 \text{ g}}{100 \text{ cm}^3} = 9.1 \text{ g.}$$

If 1 litre contains 9.1

$$1.5 \text{ l will contain } \frac{1.5 \text{ litres} \times 9.1 \text{ g of NaCl}}{1 \text{ litre}}$$

$$= 13.659 \text{ g of NaCl.}$$

Therefore, 13.659 g of NaCl are used to prepare 1.5 litres of NaCl aqueous solution

2. The weight of KCl is 20% of the total weight of solution i.e.  $(20/100 \times 30\text{g}) = 6.0\text{g}$  of KCl. The remainder of the solution (i.e.  $30 - 6 = 24$ )g consists of water.

Therefore dissolve 6.0g of KCl in 24g of water.

3. The amount of KOH required is  $0.120 \text{ l} \times 0.10 \text{ mol} = 0.012 \text{ mol}$

Molar mass of KOH is 56.1g

$$\text{Number of moles (n)} = \frac{\text{Mass (m)}}{\text{Relative molar mass (Rmm)}}$$

$$\begin{aligned} \text{Therefore, m} &= n \times \text{Rmm} \\ &= 0.012 \times 56.1 \\ &= 0.67\text{g} \end{aligned}$$

Therefore, dissolve 0.67g of KOH in water then add sufficient amount of water to make it to one litre.

## 7.2 Preparation of standard solutions

*Refer to Learner's Book*

### Lesson 2: Preparations of various standard solutions (to be covered in six periods)

#### Specific objectives

By the end of the lesson, learners should be able to prepare various standard solutions.

#### Preparation for the lesson

The lesson will be taught in six periods. It will involve activities by learners to prepare standard solutions and carrying out calculations.

You are therefore expected to get the various materials well in advance and do sample titrations. The learners should be organised in the class and laboratory in a way that will encourage the teaching activities suggested.

#### Suggested teaching aids

- Provide exercises to different groups and present to the whole class at the blackboard.
- A chart containing how to prepare various standard solutions.
- You may come up with your own examples of calculations charts on manila papers if your school does not have charts.
- A video showing how solutions of different substances can be determined.

#### Pre-requisite to the unit

Learners should be aware that we always

work from the known to unknown. This is why standard solutions are prepared so as to determine the unknown.

#### Suggested teaching and learning activities.

1. Introduce the lesson by informing learners that standard solutions are prepared by dissolving a certain amount of solute in a given amount of water. In this lesson they are going to learn how to prepare various solutions.
2. Inform learners that molar solutions are expressed by the number of moles dissolved in one litre the solution.
3. Organise learners into convenient groups according to availability of resources. Let them carry out activity 7.2 in the Learner's Book.
4. Guide learners in setting up apparatus and instruct them to follow the laid down procedures for each experiment.
5. Inform them to note down their observations and results in their notebooks.
6. Allow learners to discuss their findings, write a report and present it in class.
7. Use their presentations to discuss the preparation of solutions as outlined in the Learner's Book as they take notes.
8. Take learners through the various example suggested in the Learners

- Book on how to calculate dilutions.
- Give learners more exercises and examples.
  - Use the preparation of 0.1M sodium hydroxide solution discussed below.

### Preparing a of standard solution of 0.1M sodium hydroxide using sodium hydroxide pellets

#### Requirements

Sodium hydroxide pellets, electronic or balance, spatula, 250 ml volumetric flask, droppers, beaker, filter funnel and distilled water.

#### Procedure

Ask learners to work out mass of sodium hydroxide needed to make up the solution, for example:

1mole of sodium hydroxide weighs  
 $23 + 16 + 1 = 40\text{g}$

0.1moles of sodium hydroxide weighs  $0.1 \times 40\text{g} = 4\text{g}$

$1000\text{cm}^3$  of 0.1M NaOH solution contain 4g

$250\text{cm}^3$  of 0.1M NaOH solution contain  $(250/1000) \times 4 = 1\text{g}$

**Note:** sodium hydroxide is deliquescent and its mass cannot be exactly measured.

You are required to weigh out approximately 1g of sodium hydroxide and place into a 250 ml volumetric flask and little water shake to dissolve all the pellets. Add more distilled water up to

the mark. This solution can be labelled as 0.1M NaOH.

Learners can make solutions of 1M NaOH, 0.5 M NaOH, 2 M NaOH as an exercise

- Let the learners appreciate the essence to respect procedure during practical activities and of team work in group activities.
- At this point the teacher can give a summary of preparing standard solutions.
- End the lesson by instructing learners to attempt question in Self-evaluation Tests 7.2.

#### Synthesis

This lesson introduces the concept of preparation of different solutions used for example, in hospitals for dilution of drugs such as cough syrup as well as disinfectant solutions. Through activities, learners should discover that drugs must be taken in right proportions and right concentrations for their efficacy.

#### Suggested lesson assessment

Assess whether the learning objective of the lesson was met by asking questions such as:

- What mass of pure substance is contained in each of the following solutions:
  - $2500\text{ cm}^3$  of 0.2 M hydrochloric acid



- b.  $500 \text{ cm}^3$  of 0.1M potassium hydroxide solution
  - c.  $500 \text{ cm}^3$  of 0.1M ammonia solution.
2. What mass of pure substance is contained in each of the following solutions?
    - a.  $250 \text{ cm}^3$  of 0.1M sodium carbonate
    - b.  $500 \text{ cm}^3$  of 0.2M sodium carbonate
    - c.  $100 \text{ cm}^3$  0.1M sodium carbonate

### Answers to Self-evaluation Test

#### 7.2

Refer to Learner's Book

1. 0.5 g
2. 8.36 g
3. Dissolve 43.8 g of ammonium hydroxide in water and the volume is made to 1L.
4. 0.01998 M
5. 0.68 l
6. 4.3 g

### 7.3 Acid – base titrations

Refer to Learner's book

#### Lesson 3: Simple acid –base titrations (to be covered in six periods)

##### Specific objectives

By the end of the lesson, learners should be able to perform simple acid – base titrations.

#### Preparation for the lesson

1. The lesson will be taught in six periods. It will involve a research activity by learners as the teacher engages learners in a discussion regarding the activity and assessing learners' achievements. The learners should be organised in the class and laboratory in a way that will encourage the teaching methods suggested.
2. You should prepare questions and exercises in advance.
3. All apparatus should be checked to find out whether they are working very well in advance.
4. Provide all necessary apparatus and material needed by learners including the experimental procedure.
5. Ask learners to begin the experiment and record results in a suitable table.

#### Suggested teaching aids

- Provide exercises to different groups and present to the whole class at the blackboard.
- A chart containing how to perform acid – base titrations.
- You may come up with your own examples of calculations charts on manila papers if your school does not have charts.
- A video showing how acid – base titrations.

## Pre-requisite to the unit

Learners have already tackled acid-base reactions. They will apply the knowledge in this lesson to do simple acid-base titrations.

## Suggested teaching and learning activities.

1. Introduce the lesson by informing learners that they are going to learn about simple acid-base titrations.
2. Explain the necessity of the procedure. Take learners through the steps involved. It is necessary to demonstrate the titration procedure using the apparatus and reagents required as outlined in the Learner's Book.
3. Show learners (each one of them should participate) on how to handle apparatus during titrations as outlined in the Learner's Book.
4. Discuss with learner how to present their results in a table format. See Table 7.2 in the Learner's Book.
5. Having fully grasped the titration procedure, use the example below to test their knowledge and skills.

### Simple acid-base titration between 0.1M HCl and 0.1M NaOH using phenolphthalein indicator

#### Materials and apparatus

Burette, pipette (25 ml or 20 ml), Four beakers, conical flask, phenolphthalein

indicator, 0.1M hydrochloric acid, 4g of sodium hydroxide, dropper, and retort stand with clamps fixed.

#### Procedure

- a. Measure on a watch glass about 1g of sodium hydroxide.
  - b. Transfer it to a beaker and dissolve in water. Make up the solution to about 250 ml and shake well.
  - c. Place 25 ml or 20 ml or 10ml of the alkali in each of the four flasks.
  - d. Add 2 drops of indicator and titrate until three results have been obtained. Any indicator except phenolphthalein is suitable.
  - e. Calculate the molarity of sodium hydroxide.
6. Guide learners in setting up apparatus and instruct them to follow the laid down procedures for each experiment.
  7. Inform them to note down their observations and results in their notebooks.
  8. Allow learners to discuss their findings, write a report and present it in class.
  9. Use their presentation to discuss the how to perform simple acid –base titrations as outlined in the learner's book as they take notes.
  10. Thereafter take learners through the examples and the titration based calculations suggested in the Learner's Book.

11. Give learners more exercises and examples.
12. At this point you can give a summary of the procedure involved in simple – acid base titrations.
13. End the lesson by instructing learners to attempt question in Self-evaluation Test 7.3 and Test your Competence 7.

### Synthesis

The learners should understand acid- base titrations are important procedures in industries especially food based, pharmaceutical and chemical industries. In these industries they have to determine the optimum point of a reaction in order to save on production cost as well as produce quality products.

### Suggested lesson assessment

Assess whether the learning objective of the lesson was met by asking questions such as:

1. How many moles of  $\text{Na}_2\text{CO}_3$  are there in 10.0 L of 2.00 M solution?  
Ans: 20 moles
2. What is the molarity of 5.00 g of NaOH in 750.0 ml of solution?  
Ans: 0.167M
3. Sea water contains roughly 28.0 g of NaCl per litre. What is the molarity of sodium chloride in sea water?

Ans:  $MV = \text{grams/molar mass}$

$$X = 28/58.44$$

$$X = 0.478 \text{ M}$$

### Answers to Self-evaluation Test 7.3

Refer to Learner's book

1. 0.2 mol/L
2. 0.179 mol/L
3. (a)  
Potassium hydroxide + sulphuric acid  
↓  
Potassium sulphate + water  
 $2\text{KOH}(\text{aq}) + \text{H}_2\text{SO}_4(\text{aq}) \rightarrow$   
 $\text{K}_2\text{SO}_4(\text{aq}) + 2\text{H}_2\text{O}(\text{l})$   
(b) Methyl orange indicator  
(Red to yellow)  
(c) 2.33 mol/dm<sup>3</sup>  
(d) Add barium chloride to the test solution. A white precipitate is a confirmatory test.
4. 0.125 M
5. (a) 1.71 moles  
(b) 0.450 dm<sup>3</sup>  
(c) 3.8M  
(d) 50g
6. 4 M
7. 36 g
8. 0.2 moles, 19.6 g
9. 0.12M
10. 0.91 mol/l

## Summary of the unit

This unit helps learners to prepare solutions of different concentrations and appreciate the importance of accuracy in measurements.

Learners are taught how to mix solutions and obtain their concentrations. This is vital in pharmacy and production of drugs and other chemicals. Therefore the skills, knowledge and attitude obtained will enable the learners to pursue careers in medicine and pharmacy.

## Additional information for the teacher

The process of obtaining quantitative information of a sample using a fast chemical reaction by reacting with a certain volume of reactant whose concentration is known is called titration. When an acid-base reaction is used, the process is called acid-base titration. When a redox reaction is used, the process is called a redox titration. Titration is also called volumetric analysis, which is type of quantitative chemical analysis.

In Chemistry titration is a technique where a solution of known concentration is used to determine the concentration of an unknown solution. Typically, the titrant (the known solution) is added from a burette to a known quantity of the analyte solution of unknown concentration until the reaction is complete. Knowing the volume of titrant added allows the determination of the concentration of the unknown. Often, an

indicator is used to usually signal the end of the reaction, the endpoint.

In hospital and medical labs, automated titration equipments are used. The following sites have some information regarding the automated titrator

## Titration procedure

1. Clean the burette with distilled water.
2. Rinse the burette with the acid that will be used for the titration.
3. Fill the burette with the acid. Let a little run out through the stopcork.
4. Record the initial burette reading.
5. Use a pipette to transfer the base solution into a conical flask.
6. Record the volume moved by the syringe.
7. If you are using an indicator, add a few drops to the flask.
8. Slowly add the acid from the burette to the flask. Swirl the flask as you titrate. Be careful. Avoid acid drops landing on the sides of the flask.
9. Stop titration when the slight color change become permanent. This is the end point.
10. Record final reading of the burette.
11. Repeat for remaining titrations

## Reading measurements

Always read burettes at eye level.

Always read from the bottom of the meniscus. In a plastic apparatus, there is often no meniscus.

Burettes are accurate to 2 decimal places. Learners should estimate to the nearest 0.01 ml.

### Acid-Base indicators

The less indicator used, the better. To change colour, the indicator must react with fluid in the burette. If you add too much, it uses more chemical than necessary for neutralisation, creating an indicator error.

#### Common acid- base indicators

Indicator are key component in the acid base titrations because they show the end point of neutralisation. These indicators are:

- Litmus solution: (red-blue)
- Methyl orange (red-orange): this is an excellent indicator to use when titrating strong acid and a weak base
- Methyl red: (red- yellow) this is more sensitive (gives a sharper end point) than methyl orange
- Phenolphthalein indicator: colourless to pink, suitable for strong acids and strong bases.

### Common calculations in titration experiments

All REB practical experiments require learners to determine some unknown in the titration procedure. Common calculations that the problem statement will ask for include:

- Concentration (molarity) of an acid or base.
- Relative atomic mass of unknown

elements in an acid or base.

- Percentage purity of a substance.
- Amount of water of crystallisation in a substance.

### Concentration of an Acid or Base

The problem statement may have the learner to find either the unknown molarity (moles per litre) or concentration (grams per litre) of the acid or the base. As an example, the following steps are used to calculate the unknown concentration of an acid:

- Calculate the average volume of acid used. Remember not to use the pilot trial or any trials that are not within  $\pm 0.2 \text{ cm}^3$  of each other.
- Calculate the number of moles of the base used.

Molarity = number of moles/volume of solution

These values can usually be taken from the solutions listed on the test paper. Also be sure that the units of volume of solution are in litres or  $\text{dm}^3$ .

- Write a balanced chemical equation for the reaction. The chemical equation can also be written as an ionic equation.
- Calculate the number of moles of acid used from the mole ratio taken from the balanced chemical equation. Both ionic and full formulae equations give the same mole ratio.
- Work out the molar concentration of the acid.

The molar concentration can be

determined using the calculated number of moles of acid (found in the previous step) and the average volume of acid used (found in step 1), using the equation in step 2.

Alternatively, the following equation can be used:

$C_A V_A / C_B V_B = n_A / n_B$  Where:

$C_A$  is the molar concentration of the acid.

$V_A$  is the volume of the acid used.

$n_A$  is the number of moles of the acid used.

$C_B$  is the molar concentration of the base.

$V_B$  is the volume of the base used.

$n_B$  is the number of moles of the base used.

Similar steps are used to calculate the unknown concentration of a base.

Repeat steps 1 through 5, but with the following changes:

Step 2: Calculate the moles of the acid used.

Step 4: Calculate the moles of the base from the mole ratio.

Step 5: Find the molar concentration of the base, either using the molarity calculation or the equation above.

## End of unit assessment

This section is divided into two parts:

- Answers to test your competence 7
- Additional exercises for unit assessment (consolidation exercise)

### a) Answers to Test your Competency 7

*Refer to Learner's Book*

1. A
2. B
3. C
4. A
5. C
6. C
7. C
8. C
9. D
10. A
11. D
12. D
13. C
14. Unknown, titration, volume, pipette, conical, indicator, acid, burette, orange end point, neutralised.

## Additional End of Unit Assessment exercises

### (Consolidation exercises)

1. Use the following words to fill the gaps in the passage below.

*Indicator, volume, unknown, conical, titration, pipette, acid, orange, burette, neutralised, end-point.*

The technique used to find the concentration of an i) \_\_\_\_\_ solution is called a ii) \_\_\_\_\_. In an acid-base titration, a certain iii) \_\_\_\_\_ of the base, for example 25 cm<sup>3</sup> is measured out using a iv) \_\_\_\_\_ and poured into a

v) \_\_\_\_\_ flask and an vi) \_\_\_\_\_ is added. The vii) \_\_\_\_\_ is slowly and carefully added to the measured volume of the base using a viii) \_\_\_\_\_ until the indicator, for example, methyl ix) \_\_\_\_\_, just changes colour. This is called the

x) \_\_\_\_\_. The indicator is used to show when the base has been completely

xi) \_\_\_\_\_ by the acid.

Ans: i) unknown      ii) titration

iii) volume      iv) pipette

v) conical      vi) indicator

vii) acid      viii) burette

ix) orange      x) end point

xi) neutralised

2. Which one of the following pieces of apparatus would you NOT use during titration?

A. Liebig condenser      B. Burette

C. Pipette filler      D. Conical flask

Ans: A

3. Write an equation for the reaction between hydrochloric acid and sodium carbonate in a titration process.

Ans:  $\text{Na}_2\text{CO}_3 (\text{s}) + 2\text{HCl}(\text{l}) \rightarrow 2\text{NaCl} (\text{aq}) + \text{H}_2\text{O} (\text{l}) + \text{CO}_2 (\text{g})$

4. Before starting titration process, the pipette, burette and conical flask are rinsed using deionised water and NOT tap water. Why is this the case?

Ans: Tap water contains ions that may affect the titration result.

5. When placing the acid in the burette during titration, which one of the following procedures is INCORRECT?

A. The top of the meniscus is read when doing the titration.

B. Any air bubble below the tap is removed before the titration.

C. The funnel is removed from the top of the burette before titration begins.

D. The burette is filled to the zero mark when filling it up.

Ans: A

6. Why is sodium carbonate mixed with the hydrochloric acid in a conical flask rather than a beaker during titration?

Ans: To prevent any of the solutions splashing out when swirling the flask.

7. In titration, when adding the indicator to the conical flask, only two or three drops are added because?

(i) Too much indicator may make it difficult to see the colour change at the end-point clearly,

(ii) The indicator is corrosive and adding too much poses a greater risk of corrosion.

(iii) The indicator may be a weak acid or base and may interfere with the titration results.

Which of the above statements is/are correct?

A. (i) and (ii) only

B. (ii) and (iii) only

C. (iii) only

D. All of them

Ans: C

8. If  $25 \text{ cm}^3$  of  $0.1 \text{ M}$  sodium carbonate solution is used in a titration, how many moles of sodium carbonate is this?

A.  $0.0025$  mole

B.  $2.5$  moles

C.  $0.025$  mole

D.  $0.25$  mole

Ans: A

9. If the colour of the indicator at the end-point of the titration changes from pink to colourless, which one of the following indicators was most likely to have been used?

A. Litmus indicator

B. Universal indicator

C. Phenolphthalein

D. Methyl orange

Ans: C

10. How many titrations should be carried out in order to give valid results?

Ans: one rough titration and two accurate titrations that agree to within  $0.1 \text{ cm}^3$  of each other.



## Extended and remedial exercises

Remedial activities for slow learners	Extended activities for gifted and talented learners
<ol style="list-style-type: none"><li>1. Collecting, cleaning and arranging apparatus and reagents in the laboratory.</li><li>2. Collect various materials and objects at home for experiments.</li><li>3. Drawing diagrams from charts on their notebooks</li></ol>	<ol style="list-style-type: none"><li>1. Do further research in textbooks or the internet about carbon and its inorganic compounds. Write short notes then share with other class members.</li><li>2. Set up experimental apparatus for practicals in the laboratory.</li><li>3. Come up with a project for making dyes from carboxylic acid. Use locally available materials and make the item.</li></ol>

*Refer to Learner's book***Key Unit Competence**

After studying this unit, the learner should be able to examine and explain the electrolysis of different electrolytes and state their applications in daily life.

**Learning objectives**

Competency based curriculum embraces three categories of learning objectives,

that is, knowledge and understanding, skills acquisition and attitude and values. At the end of the unit, learners should have knowledge and understanding of the speed/rate of chemical reaction and appreciate the importance of chemical reaction in everyday life like burning of fuel that provide energy to run the machine and vehicles.

**Table 8.1 Knowledge, skills and values to be attained**

Knowledge and understanding	Skills	Attitudes and values
<ul style="list-style-type: none"> <li><input type="checkbox"/> Explain the concept of electrolysis (ionic theory by Arrhenius 1880).</li> <li><input type="checkbox"/> Describe the formation of gases and metals on cathode and anode electrodes.</li> <li><input type="checkbox"/> Explain the applications of electrolysis.</li> <li><input type="checkbox"/> Give products of electrolysis for different solutions or molten salts (e.g. molten sodium chloride, concentrated sodium chloride solution, copper sulphate solution using platinum electrodes and using copper electrodes.).</li> </ul>	<ul style="list-style-type: none"> <li><input type="checkbox"/> Predict the products of the electrolysis of: molten lead bromide, concentrated sodium chloride (brine), molten sodium chloride, and electrolysis of acidified water (dilute sulphuric acid).</li> <li><input type="checkbox"/> Carry out an experiment to investigate the electrolysis of copper (II) sulphate solution.</li> <li><input type="checkbox"/> Write balanced equations to represent reactions that take place at each electrode during electrolysis.</li> <li><input type="checkbox"/> Write balanced redox equations in terms of loss of oxygen or gain of hydrogen and vice-versa. Loss and gain of electrons.</li> <li><input type="checkbox"/> Perform an experiment to electro-plate a silver coin using copper(II) sulphate/nitrate solution.</li> </ul>	<ul style="list-style-type: none"> <li><input type="checkbox"/> Develop a culture of working in a team.</li> <li><input type="checkbox"/> Develop orderliness especially during experiments and presentations.</li> <li><input type="checkbox"/> Respect for the procedures of an experiment.</li> <li><input type="checkbox"/> Appreciate the importance of electrolysis in daily life.</li> <li><input type="checkbox"/> Develop self confidence in handling electrical apparatus/ chemicals.</li> </ul>

## **Pre-requisite to the unit**

Learners have learnt about solutions, ions, molecules and compounds from previous lessons. They have also learnt about electricity and its effects. From learner's daily lives they have encountered electrolytes.

Review all these with the aim of preparing learners for this unit on electrolysis and its application in daily life.

## **Links to other subjects**

During the lessons, strive to bring to the attention of learners the fact that this topic is related to electricity in physics they covered in Senior 1, 2 and 3. Details of electricity will be met in Senior 4. Bring to attention of the learners that battery cells we use here at school and in our homes converts chemical energy into electrical due to chemical reactions that take place inside. Inform the learners that the details of how the dry cell work will be taught in advanced level chemistry in electrochemistry.

## **Background Information**

Oxidation and reduction is linked to corrosion or rusting of metallic substances because it involves addition of oxygen to iron and lead to its destruction.

Before we study electrolysis it is very important to have the idea of oxidation and reduction reactions as another type of reaction in addition to the types discussed in Senior 2.

In electrolysis, you will investigate the conductivity of electricity in solution or molten states by different electrolytes.

## **Cross-cutting issues to be addressed**

### **1. Standardisation culture**

Bring to the attention of learners the need to check the expiry dates of non-rechargeable battery cells because the reactions which occur inside them go to completion and the cell stop functioning.

### **2. Financial education**

Emphasis should be put to proper use of electricity irrespective of the source. To always remember to switch off bulbs and other electric appliances when not in use. All these have financial implications in terms of cost.

### **3. Gender education**

Both boys and girls should participate equally in all activities. Emphasise to learners that anybody irrespective of their gender can pursue a career in any chemistry field. Give examples of role models who are successful in their career locally.

### **4. Inclusive education**

All learners should be encouraged to participate during lessons and practicals. Special arrangements should be done to take care of learners with special needs. For example, provide braille for blind learners, large print text for those with sight problems and allocate physically challenged learners to others to assist them during field trips and practical activities. Further, this category should be given tasks that they can manage during the practical sessions.

## **5. Environment and sustainability education**

Bring to the attention of learners the need to conserve electricity and use of it efficiently .

## **6. Peace and values education**

Emphasise to learners the importance of working harmoniously with each other during group work and class activities.

## **7. Health education**

Emphasise to learners that electricity is dangerous and should be handled with care.

## **Generic Competences**

### **1. Research skills**

Guide learners on how to find information regarding various topics, on how to come up with summarised notes from a large body of text and on how to do internet searches for the various content areas they are looking for.

### **2. Communication in English**

Communication in English will be improved when learners freely participate in the discussions and presentations. Encourage all learners irrespective of their abilities to participate in group discussions, during presentations by asking questions and during question and answer sessions to either introduce or wrap up the lessons.

## **3. Cooperation and interpersonal management and life skills**

During group discussions and pair-work let learners engage one another by giving a chance for all to participate. Also, during group presentations, you can allow rotational presentations within the group members. Gifted learners should help in coming up with presentation content as slow learners contribute.

**Note:** You should allow progressive gradual learners to do presentations as well and correct them where they go wrong. Advise learners to appreciate the different abilities of their group members and accommodate each other's views.

### **4. Critical thinking and problem solving skills**

This competence will be developed by learners as they answer the probing questions at the beginning of this unit and as they discuss the results of the various practical activities. Guide learners to discover for themselves electrolysis and its application. This competence will also come about as learners think about their findings in the activities and as they give out their suggestions.

### **5. Lifelong learning skills**

Efficient usage of electricity will conserve the environment e.g for non-renewable sources of electricity. Make learners aware of this fact as most production of electricity depletes natural resources in a country.

## Key words in this unit and their meanings

- **Anion** – Negative ion
- **Anode** – Positive electrode connected to positive terminal of d.c. source.
- **Cathode** – Negative electrode connected to negative terminal of d.c. source.
- **Cation** – positive ion
- **Discharge** – the removal of electrons from negative ions to form atoms or the gain of electrons of positive ions to become atoms.
- **Electrolysis** – decomposition of a compound using electricity.
- **Electrolyte** – an ionic compound which conducts electric current in molten or aqueous state, while being decomposed in the process.
- **Electrode** – a rod or plate where electricity enters or leaves electrolyte during electrolysis. Reactions occur at electrodes.
- **Electroplating** – the process of coating a layer of metal onto another by electrolysis.

□ **Oxidation** – the loss of electrons or an increase in oxidation state by a molecule, atom, or ion.

□ **Reduction** – the gain of electrons or a decrease in oxidation state by a molecule, atom, or ion.

## Guidance on the brain teaser

In this topic, you will teach about electrolysis and its applications. As a way of introducing these concepts, refer learners to the pictures on of Learner's Book. The pictures show electrolytic cell. Allow learners in groups to discuss the cell. The groups should be constituted based on the learners abilities and class size. Let them give answers to the probing questions associated with the picture.

You can then guide the learners to discover what they will learn in this topic. Further, emphasise the need for taking this topic seriously in the course of the lessons as it can lead to environmental awareness.

## Attention to special educational needs

Support for multi ability learning	Support for special needs learning
<ul style="list-style-type: none"> <li><input type="checkbox"/> Slow learners should be encouraged to take part in the learning process such as in discussions, presentations and research activities.</li> <li><input type="checkbox"/> Gifted learners can do research and write reports of these findings.</li> <li><input type="checkbox"/> Both gifted and progressive gradual learners should be given equal opportunities in group discussions and presenting their findings.</li> <li><input type="checkbox"/> Ensure that all learners work in harmony and as a team.</li> </ul>	<ul style="list-style-type: none"> <li><input type="checkbox"/> During demonstrations, allocate roles to the physically challenged as long as they can handle them.</li> <li><input type="checkbox"/> Ensure physically challenged learners get enough support from other learners during movement and when handling apparatus and reagents.</li> </ul>

## List of lessons

Lesson Number	Lesson title	No. of periods
1	Introduction to oxidation – reduction reactions	3
2	Electrolysis of solutions and molten compounds	10
3	Application of electrolysis	3
4	End of unit assessment test	2

### 8.1: Introduction to oxidation – reduction reactions

#### Lesson 1: Oxidation – reduction reactions (To be covered in three periods)

*Refer to Learner's Book*

#### Specific objectives

By end of the lesson, learners should be able to:

- Define oxidation and reduction in terms of oxygen and hydrogen, increase and decrease in oxidation number, loss and gain of electrons.

- Explain the concept reducing and oxidizing agents.
- Write equations showing oxidation and reduction in terms of oxygen and hydrogen, increase and decrease in oxidation number, loss and gain of electrons.
- Appreciate the importance of oxidation and reduction in daily life.

#### Preparation for the lesson

1. This lesson will involve group activities, experiments and research activity. You will therefore organise the class as need arises during the lesson.

**Note:** When grouping learners, you should consider the different abilities of learners and the special needs for various individuals.

2. Refer the learners to the procedure as provided in activity 8.1 and assist them arrangement of the apparatus
3. All experimental apparatus and ensure that they are working before the lesson begins.

### Suggested teaching aids

- Learner's Books
- Charts on oxidation-reduction reactions
- Internet links
- Chalkboard diagrams
- Dictionary
- Video link to the learners

### Pre-requisite to the lesson

Introduce the unit as explained under guidance statement above then narrow down to this lesson.

### Suggested teaching and learning activities

1. Ask probing questions to introduce the lesson. Such questions may include:

- What is a chemical reaction?

*Ans: Reaction that involves the formation of new substances from reactants, change in mass, evolution or absorption of energy etc.*

- Can you name some chemical reactions that occur in nature?

*Ans: Respiration, photosynthesis, rusting etc.*

2. Organise students into convenient groups according to availability of resources. Prepare in advance as they will carry out experiment 8.1 in the learner's book. This is a group experiment activity intended to bring out the idea of oxidation and reduction.
3. Provide learners with the materials needed in the activity and the procedure.
4. Guide learners in setting up apparatus and instruct them to follow the laid down procedures for each experiment.
5. Inform them to note down their observations and results in their notebooks.
6. Let learners have a brief discussion session on their findings then write summary notes and present it in class.
7. Use their presentation to discuss the oxidation-reduction reactions as outlined in the Learner's Book as they take notes.
8. Let the learners appreciate the essence to respect procedure during practical activities and appreciate development of team work in group activities.
9. At this point the teacher can give a summary of the oxidation-reduction reactions.

## Synthesis

The lesson introduces learners to oxidation-reduction reactions. The activities carried out during the lesson should help learners identify how redox reaction apply in daily life.

### Suggested lesson assessment

Assess whether the learning objectives of the lesson are being met by asking questions such as:

1. What did you learn in this lesson?

*Ans:*

*Experiment to investigate the concept of oxidation and reduction.*

2. What is oxidation and reduction?

*Ans: oxidation: addition of oxygen or removal of hydrogen, increase in oxidation number, loss of electrons.*

*Reduction: addition of hydrogen or removal of oxygen, decrease in oxidation number, gain of electrons.*

3. Suppose respiration was allowed to take place without oxygen, suggest what would happen in our bodies?

*Ans: less energy would be produced hence reduce the rate of heart beat and reduced activity of the brain and other parts of the body.*

4. Using examples define reducing agent and oxidizing agent.

*Ans: Refer to Learner's Book*

## 8.2: Electrolysis of solutions

*Refer to learner's book*

### Lesson 2: Electrolysis of solutions and molten compounds (To be covered in ten periods)

#### Specific objectives

By end of the lesson, learners should be able to:

- Explain the concept of electrolysis (ionic theory of electrolysis by Arrhenius in 1880).
- Explain the factors affecting the discharge of ions during electrolysis.
- Describe what happens at each electrode during electrolysis.
- Write equations for reactions that take place at each electrode during electrolysis.
- Appreciate the importance of electrolysis in everyday life.

#### Preparation for the lesson

1. This lesson will involve research activities and experiments. You will therefore organise the class and laboratory as need arises during the lesson.

**Note:** When grouping learners, you should consider the different abilities of learners and the special needs for various individuals.

2. Provide the experimental procedure and make available the apparatus to the learners in all the activities.
3. Ensure all experiment apparatus are working before the lesson begins.



## Suggested teaching aids

- Learner's books
- Charts on electrolysis of solutions
- Charts showing the arrangement of the apparatus and the procedure for each group
- Chalkboard diagrams
- Video link to the learners
- Reference books and pamphlets
- Apparatus and reagents

## Pre-requisite to the unit

Learners have encountered electrolytes in their daily lives. In this lesson they are going to learn how electrolysis take place.

## Suggested teaching and learning activities

1. Introduce the lesson by recapping the previous lesson of oxidation-reduction reactions. Inform learners that in this lesson they will learn about electrolysis of solutions.
2. They will study about electrolysis of acidified water, dilute sodium chloride, concentrated sodium chloride, copper sulphate and molten compounds. You will tackle each separately as you explain to learners how the reactions takes place.
3. Begin by discussing with learners the Arrhenius theory electrolysis. This help learners understand how ions are formed and move in solutions as outlined in the Learner's Book.

Thereafter introduce the electrolysis of substances one at a time.

## A. Electrolysis of acidified water (dilute sulphuric acid)

*Refer to Learner's Book*

1. Organise Learners into convenient groups according to availability of resources. Introduce experiment 8.2 in the Learner's Book.
2. Guide learners in setting up apparatus and instruct them to follow the laid down procedures for the experiment. Assist them where necessary when setting up the experiment. Inform them to be careful when handling the apparatus and reagents. Some may be dangerous. Ask them to note down their observations and results in their note books. Allow learners to discuss their findings, write a report and present it in class.
3. Use their presentations to discuss the electrolysis of acidified water as outlined in the Learner's Book as they take notes. Stress the writing of equations for the reactions at the electrodes i.e. anode and cathode and the overall equation for the reaction. Let the learners appreciate the purpose to respect procedure during practical activities and appreciate development of team work in group activities.
4. At this point give a summary of electrolysis of acidified water. Let the learners watch the video carefully in case the apparatus is missing.

They should note movement of ions during electrolysis.

## **B. Electrolysis of dilute sodium chloride**

*Refer to Learner's Book*

1. Organise learners into convenient groups according to availability of resources. Introduce experiment 8.3 in the Learner's Book.
2. Guide learners in setting up apparatus and instruct them to follow the laid down procedures for the experiment. Assist them where necessary when setting up the apparatus for the experiment. Inform them to be careful when handling the apparatus and reagents. Some may be dangerous. They should make proper observations, record the results from the experiment. Discuss the findings in their respective groups. Let the learners present their findings to the whole class.
3. Use their presentation to discuss the electrolysis of dilute sodium chloride as outlined in the Learner's Book as they take notes. Stress the writing of equations for the reactions at the electrodes i.e. anode and cathode and the overall equation for the reaction.
4. At this point give a summary of electrolysis of dilute sodium chloride.

## **C. Electrolysis of concentrated sodium chloride (Brine)**

*Refer to Learner's Book*

1. Organise learners into convenient groups according to availability of resources. Introduce experiment 8.4 in the Learner's Book.
2. Guide learners in setting up apparatus and instruct them to follow the laid down procedures for the experiment. Assist them where necessary when setting up the experiment.
3. They should make proper observations, record the results from the experiment. Discuss the findings in their respective groups. Let the learners present their findings to the whole class.
4. Use their presentations as platform to discuss the electrolysis of concentrated sodium chloride as outlined in the Learner's Book as they take notes. Stress on the writing of equations for the reactions at the electrodes i.e. anode and cathode and the overall equation for the reaction.
5. Let learners organise for a role play as suggested in the Learner's Book. The role play will enable learners visualise how ions move to the terminals and eventually released. Let the learners appreciate respect for procedure during practical activities and appreciate development of team work in group activities.

6. At this point give a summary of electrolysis of concentrated sodium chloride.

#### **D. Electrolysis of copper (II) sulphate (using inert electrodes)**

*Refer to Learner's Book*

1. Organise learners into convenient groups according to availability of resources. Introduce experiment 8.6 in the learner's book.
2. Guide learners in setting up apparatus and instruct them to follow the laid down procedures for the experiment. Assist them where necessary during the experiment.
3. They should make proper observations, record the results from the experiment, discuss the findings in their respective groups. Let the learners present their findings in the class. Stress the writing of equations for the reactions at the electrodes i.e. anode and cathode and the overall equation for the reaction.
4. Compare the products formed in this with the previous experiment.
5. At this point give a summary of electrolysis copper (II) sulphate (using copper electrodes).

#### **E. Electrolysis of molten compounds**

*Refer to Learner's Book*

1. Let learners pair up and do a research as suggested in the Learner's Book. They will carry out research on electrolysis of molten compounds.

2. Provide them with the necessary research materials. They will write a report which they will present to the class.
3. Build on their presentation to discuss electrolysis of molten compounds as outlined in the Learner's Book as they take notes.
4. Explain to learners the reactions that take place at the electrodes i.e. anode and cathode and the overall equation for the reaction.
5. At this point give a summary of electrolysis of molten compounds.
6. End the lesson by instructing learners to attempt Self-evaluation Test 8.1 and 8.2.

#### **Synthesis**

This lesson introduces learners to the concept of electrolysis of solutions and molten compounds. Use the experiments to investigate how the ions move during electrolysis and factors affecting the discharge of ions.

#### **Suggested lesson assessment**

Assess whether the learning objectives of the lesson are being met by asking questions such as:

1. Describe the Arrhenius theory of ionic compounds.

*Ans: This theory states that electrolytes consists of ions, which are positively and negatively charged atoms or radicals e.g.*  
$$\text{NaCl} \longrightarrow \text{Na}^+ + \text{Cl}^-$$

2. Explain the factors affecting the discharge of ions during electrolysis.
- Position of the metal or radical group in the electrochemical series/ activity series. Any ion is discharged in preference to those above it in the activity series.
  - Concentration: an ion in high concentration will tend to be discharged in preference to those in low concentration.
  - Nature of the electrode: inert or unreactive electrodes, like platinum and carbon, do not affect the ions to be discharged. Active electrodes like copper do take part in the electrolysis.

### Answers to Self-evaluation Test

#### 8.1

Refer to Learner's Book

1. Positive, cathode, anode, hydrogen, gas, lose, oxygen.
2. Molten sodium chloride forms sodium and chloride ions only while dilute solution of sodium chloride forms sodium, chloride, hydrogen and hydroxide ions.
3.
  - a.  $\text{Pb}^{2+}(\text{aq}) + 2\text{e}^{-} \rightarrow \text{Pb}(\text{s})$
  - b.  $2\text{H}^{+}(\text{aq}) + 2\text{e}^{-} \rightarrow \text{H}_2(\text{g})$
  - c.  $4\text{OH}^{-}(\text{aq}) + 4\text{e}^{-} \rightarrow 2\text{H}_2\text{O}(\text{l}) + \text{O}_2(\text{g})$
  - d.  $2\text{Cl}^{-} \rightarrow \text{Cl}_2(\text{g}) + 2\text{e}^{-}$

### Answers to Self-evaluation Test

#### 8.2

Refer to Learner's Book

1.

	Copper electrodes	Inert electrodes
<b>Anode</b>	Electrode dissolves	OH <sup>-</sup> , leads to discharge of oxygen
<b>Cathode</b>	Deposition of copper therefore increase in mass of cathode	Copper preferentially discharged

2. Electrolysed, copper, impure, solution, cathode

## 8.3 Application of electrolysis

### Lesson 3: Application of electrolysis (To be covered in three periods)

Refer to learners books

#### Specific objectives

By the end of the lesson, learners should be able to:

- Describe what happens during electroplating process.
- Write equations that take place at each electrode during electroplating.

#### Preparation for the lesson

This lesson will be taught in three lessons. It will involve the study of the applications of electrolysis. The lesson also involve activity 8.7 in the Learner's Book, discussions and research work. The teacher should guide the learners in these activities and assess the learners' achievement as they make

their presentations. Therefore, you are required to set the laboratory in advance and organise the class in a way that will encourage the teaching activities suggested.

### **Suggested teaching aids**

- Materials / apparatus
- Charts on electroplating
- Diagrams and pictures of application electrolysis

### **Pre-requisite to the unit**

After studying about electrolysis, learners in this lesson will understand the necessity of electrolysis in daily life.

### **Suggested teaching and learning activities**

1. Begin the lesson by asking learners to carry out research activity in the Learners Book .
2. From their findings introduce application of electrolysis as outlined in the Learner's Book.
3. Discuss each application with the aid of charts, diagrams and videos as they take notes. Bring to learner's attention the equations involved and how the reactions take place during extraction of metals, refining of metals, and manufacture of sodium hydroxide, chloride and hydrogen.
4. Inform learners that one of the most important application of electrolysis is electroplating of metals. Demonstrate this using Activity 8.7, for learners to understand better this concept.
5. Organise learners into convenient groups according to availability of resources to carry out experiment 8.7 in the Learner's Book.
6. Guide learners in setting up apparatus and instruct them to follow the laid down procedures for the experiment. Assist them where necessary when setting up the experiment.
7. Inform them to be careful when handling the apparatus and reagents. Some may be dangerous.
8. They should make proper observations, record their findings. Let them discuss their findings in their respective groups and make presentation to the class.
9. Build on their presentation to discuss electroplating as outlined in the Learner's Book as they take notes.
10. Explain to learners the reactions that take place at the electrodes i.e. anode and cathode and the overall equation for the reaction.
11. At this point give a summary of electroplating.
12. End the lesson and topic by instructing learners attempt Self-evaluation Test 8.3 and 8.4 and Test your Competence 8.

## Synthesis

This lesson investigates application of electrolysis especially electroplating a stainless spoon using copper sulphate solution. Learners through watching the video or carrying out the experiment should describe what happens during electroplating process.

## Suggested lesson assessment

Assess whether the learning objective of the lesson was met by asking questions such as:

1. Describe what happens when stainless spoon is electroplated with copper metal
2. Write equations to represent what takes place during electroplating process.

Ans: Refer to learners book

## Answers to Self-evaluation Test 8.3

Refer to Learner's Book

1. Current, electrolyte, electrodes, cathode
2. Ore, cryolite, lower, pure, energy, conductivity
- 3.

	Anode	Cathode
a	Fluorine	Sodium
b	Iodine	Copper
c	Bromine	Zinc

4. Molten compounds and aqueous solution

## Answers to Self-evaluation Test 8.4

Refer to Learner's Book .

Cathode, anode, plate, electrolyte, solution

2. The object to be plated such as a metal spoon is connected to the negative terminal of the power supply. A piece of silver metal is connected to the positive terminal. The electrolyte is silver nitrate solution.

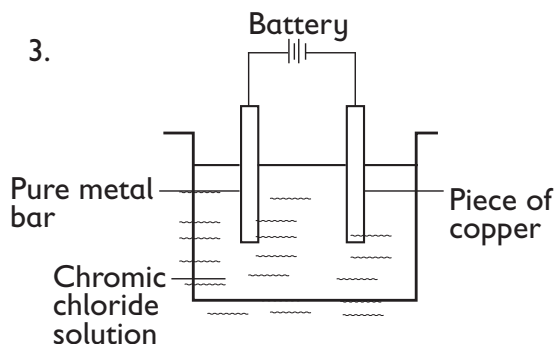
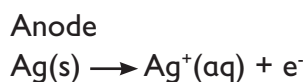
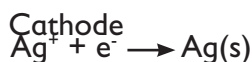

## Summary of the unit

This unit covers content on electrolysis and its applications. It should help learners investigate electrolysis of electrolytes, predict the products of electrolysis, write a balanced redox equations and perform electrolysis related experiments.

Attention has been focused on the skills and attitudes to be acquired during the learning process.

By the end of the unit, learners should be able to appreciate the importance of electrolysis in daily life.

## **Additional Information for the teacher**

### **Redox reactions**

An oxidation-reduction (redox) reaction is a type of chemical reaction that involves a transfer of electrons between two species. An oxidation-reduction reaction is any chemical reaction in which the oxidation number of a molecule, atom, or ion changes by gaining or losing an electron. Redox reactions are common and vital to some of the basic functions of life, including photosynthesis, respiration, combustion, and corrosion or rusting.

### **Electrolytic cell**

An electrolytic cell is an electrochemical cell in which the energy from an external power source is used to drive a normally non-spontaneous reaction, i.e. apply a reverse voltage to a voltaic cell. We encounter electrolytic cells during the charging phase of any type of rechargeable battery from the lead-acid battery in automobiles to the lithium-ion battery in smartphones.

In comparison to the galvanic cell, the electrodes of an electrolytic cell can be placed in a single compartment containing the molten or aqueous electrolyte. In addition, since the external battery source is what drives the electrons through the circuit, the electrodes will match the positive and negative terminal of the battery. While the anode remains the site of oxidation, it becomes the positive terminal, and the cathode becomes the negative terminal.

Another use for an electrolytic cell is for the decomposition of compounds, i.e. water, sodium chloride, into simpler compounds. Industrial processes take advantage of this in the production of chlorine or sodium hydroxide. Since electrolytic cells can be conducted in molten or aqueous electrolyte, depending on the cation and anion, the products from using a molten electrolyte may be different from the products from using an aqueous electrolyte.

In aqueous solution, at the cathode or negative electrode, if a metal is more reactive than hydrogen, then the reduced metal reacts with water to produce hydrogen gas. We can look to the activity series or a table of reduction potential to determine that the following cations are harder to reduce than water. However, if a metal is less reactive than hydrogen, then the reduced metal does not react with water, i.e. copper, platinum

### **Faraday law of electrolysis**

**Faraday's First Law of Electrolysis** states that the chemical deposition due to flow of current through an electrolyte is directly proportional to the quantity of electricity (coulombs) passed through it i.e  $m = Z \times Q$ . According to this law, mass of chemical deposition, Where,  $Z$  is a constant of proportionality and is known as electrochemical equivalent of the substance. If we put  $Q = 1$  coulombs in the above equation, we will get  $Z = m$  which implies that electrochemical equivalent of any substance is the amount of the substance deposited



on passing of 1 coulomb through its solution. This constant of passing of electrochemical equivalent is generally expressed in terms of milligram per coulomb or kilogram per coulomb.

So far we have learned that the mass of the chemical, deposited due to electrolysis is proportional to the quantity of electricity that passes through the electrolyte. The mass of the chemical, deposited due to electrolysis is not only proportional to the quantity of electricity passes through the electrolyte, but it also depends upon some other factor. Every substance will have its own atomic weight. So for same number of atoms, different substances will have different masses. Again, how many atoms deposited on the electrodes also depends upon their number of valency. If valency is more, then for same amount of electricity, number of deposited atoms will be less whereas if valency is less, then for same quantity of electricity, more number of atoms to be deposited. So, or same quantity of electricity, more number of atoms to be deposited. So, for same quantity of electricity or charge passes through different electrolytes, the mass of deposited chemical is directly proportional to its atomic weight and inversely proportional to its valency. Faraday's second law of electrolysis states that, when the same quantity of electricity is passed through several electrolytes, the mass of the substances deposited are proportional to their respective chemical equivalent or equivalent weight.

### (a) Answers to Test your competency 8

Refer to Learner's Book

1. A
2. C
3. A
4. A
5. D
6. A
7. D
8. A
9. C
10. Higher, loss, gain, electricity, chemical
11. a). No mobile particles to conduct electricity.  
b). Molecules  
c).  $H^+$ ,  $X^-$   
d). The metal ions for use in electroplating  
e). There is gaining and losing of electrons.
12. i). B  
ii). A  
iii). D  
iv). C  
v). A
13. a). Carbon  
b). A  
c). aluminum oxide (Bauxite) and cryolite  
d). It gets depleted/ corroded with time.
14. a). A-Cathode, B-Anode  
b). B



15. a). i. Reduced  
 ii. Negative  
 iii. Anode
- b). i. Solid  
 ii. No; ionic compounds are formed due to reactions between metals and non-metals
16. a). A substance that allows electric current to pass through it and itself get decomposed by it.

b).

Strong electrolyte	Weak electrolyte	Non-electrolyte
Dilute hydrochloric acid, dilute sulphuric acid, ammonium chloride, sodium acetate	Acetic acid ammonium hydroxide	Carbon tetrachloride

17. a) electrolyte b) nickel  
 c) cathode d) anode

**(b) Additional end of unit assessment exercise**

**(Consolidation Exercises)**

1. a) What is an electrolyte?

Ans: Any substance which allows electric current to pass through it and is decomposed by it.

b) Classify following substance under these sub-headings: Strong electrolytes, weak electrolytes, non electrolytes.

Acetic acid, ammonium chloride, ammonium hydroxide, carbon tetrachloride, dilute hydrochloric acid,

sodium acetate, dilute sulphuric acid, diamond, vinegar.

Ans:

Strong electrolytes	Weak electrolytes	Non electrolytes
<ul style="list-style-type: none"> <li>• Ammonium chloride,</li> <li>• Dilute Hydrochloric acid</li> <li>• Sodium acetate</li> <li>• Dilute Sulphuric acid</li> </ul>	Acetic acid  Vinegar  Ammonium hydroxide	Carbon tetrachloride  Diamond

2. Which of the following statements concerning electrolysis is INCORRECT?

- A. During electrolysis, chemical energy is converted into electrical energy.
- B. Electrolysis involves decomposition of an electrolyte.
- C. An energy supply is required for electrolysis to occur.
- D. Graphite is commonly used as the inert electrodes in electrolysis.

Ans: A

3. Choose from the list words given to correctly fill in the blanks in the passage below.

[anions, anode, cathode, cations, electrode, electrolyte, nickel, voltammeter]

To electroplate an article with nickel requires an (i) \_\_\_\_\_ which

must be a solution containing (ii) \_\_\_\_\_ ions. The article to be plated is placed as the (iii) \_\_\_\_\_ of the cell in which the plating is carried out. The (iv) \_\_\_\_\_ of the cell is made from pure nickel. The ions that are attracted to the negative electrode and discharged are called (v) \_\_\_\_\_.

Ans: i) *Electrolyte*      ii) *Nickel*

iii) *Cathode*      iv) *Anode*

v) *Cations*

4. (a) Here is an electrode reaction:

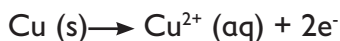

i) At which electrode (anode or cathode) would such a reaction take place?

Ans: *Anode*

ii) Is this an example of oxidation or reduction reaction?

Ans: *Oxidation*

5. Which of the following substances would not be decomposed by electricity?

- A. Molten silver
- B. Dilute sulphuric acid
- C. Concentrated sodium chloride solution
- D. Aqueous silver nitrate

Ans: A

6. The following is a sketch of electrolytic cell used in extraction of aluminium.

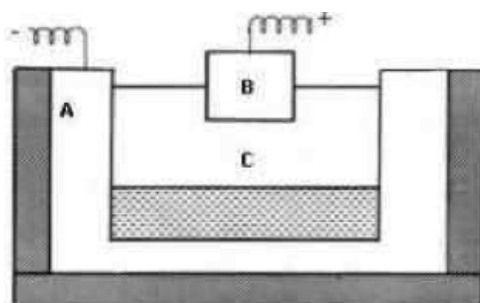

(i) What substance are the electrodes A and B made of?

Ans: *Carbon*

(ii) At which electrode (A or B) is the aluminium formed?

Ans: A

(iii) What are the two aluminium compounds in the electrolyte C?

Ans: *Aluminium oxide and aluminium hydroxide.*

(iv) Why is it necessary for electrode B to be continuously replaced?

Ans: *Because it gets corroded with time.*

7. The products of the electrolysis of dilute magnesium iodide solution using carbon electrodes are \_\_\_\_\_.

Ans: *Magnesium and iodine.*

8. Study the diagram given below and answer the questions that follow:

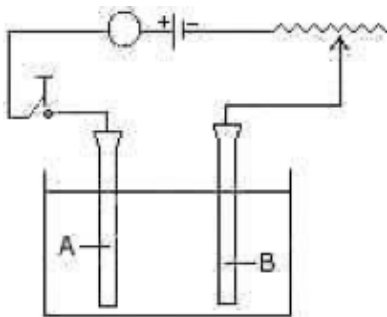

- a) Give the names of the electrodes A and B.

*Ans: A - Anode, B - Cathode*

- b) Which electrode is the oxidizing electrode?

*Ans: A*

- c) A strip of copper is placed in four different colourless salt solutions. They are  $\text{KNO}_3$ ,  $\text{AgNO}_3$ ,  $\text{Zn}(\text{NO}_3)_2$ ,  $\text{Ca}(\text{NO}_3)_2$ . Which one of the solutions will finally turn blue?

*Ans:  $\text{AgNO}_3$*

## Extended and remedial exercises

Remedial activities for slow learners	Extended activities for gifted and talented learners
<p><b>Low order thinking (LOT) questions for slow learners</b></p> <ol style="list-style-type: none"> <li>1. Explain the term 'electroplating'?</li> <li>2. Explain what happens to the copper (II) sulphate solution if copper electrodes are used.</li> <li>3. Explain why nickel (II) sulphate solution can conduct electricity.</li> </ol> <p><b>Answers Low order thinking questions</b></p> <ol style="list-style-type: none"> <li>1. It is the coating of an object with a thin layer of another metal by electrolysis.</li> <li>2. The blue colour of the electrolyte in cell 1 fades when more and more <math>\text{Cu}^{2+}</math> ions are reduced to copper metal and plated onto the cathode as a reddish brown deposit.</li> <li>3. It contains free ions</li> </ol>	<ol style="list-style-type: none"> <li>1. Come up with a project and make a device for electroplating utensils. Use locally available materials and make the item.</li> </ol> <p><b>High order thinking (HOT) questions for gifted learners</b></p> <ol style="list-style-type: none"> <li>1. What is oxidation and reduction?</li> </ol> <p><i>Ans: oxidation: addition of oxygen or removal of hydrogen, increase in oxidation number, loss of electrons.</i></p> <p><i>Reduction: addition of hydrogen or removal of oxygen, decrease in oxidation number, gain of electrons.</i></p> <ol style="list-style-type: none"> <li>2. Suppose respiration was allowed to take place without oxygen, suggest what would happen in our bodies?</li> </ol> <p><i>Ans: less energy would be produced hence reduce the rate of heart beat and reduced activity of the brain and other parts of the body.</i></p>

## Refer to Learner's Book

## Key Unit Competence

After studying this unit, learner should be able to relate the properties of alkenes and alcohols to their functional groups.

## Learning objectives

Competency based curriculum embraces three categories of learning objectives, that is, knowledge and understanding,

skills acquisition and attitude and values. At the end of the unit, learners should have knowledge and understanding of the properties and structure of alkenes and alcohols. Appreciate the importance of alcohols and alkenes in everyday life as a source of revenues through taxes and as fuel in some countries.

**Table 9.1: Knowledge and understanding, skills and attitudes and values to be attained**

Knowledge and understanding	Skills	Attitudes and values
<ul style="list-style-type: none"> <li><input type="checkbox"/> Describe the structures of alkenes, alcohols and their physical properties.</li> <li><input type="checkbox"/> Name alkenes and alcohols using the IUPAC system of naming - up to C<sub>5</sub>.</li> <li><input type="checkbox"/> State the chemical properties of alkenes and alcohols.</li> <li><input type="checkbox"/> Describe the uses and misuse of alcohols and alkenes in daily life.</li> <li><input type="checkbox"/> Describe the fermentation process.</li> <li><input type="checkbox"/> Describe the hydration of alkenes as a method of preparing alcohols.</li> <li><input type="checkbox"/> State the uses of alcohols as sources of fuel.</li> </ul>	<ul style="list-style-type: none"> <li><input type="checkbox"/> Observation skills in testing for alkenes with bromine water that involves a change of colour.</li> <li><input type="checkbox"/> Prepare alcohol by a fermentation process.</li> <li><input type="checkbox"/> Draw the structure of alkenes and alcohols.</li> <li><input type="checkbox"/> Carry out an experiment to confirm the presence of alkenes.</li> </ul>	<ul style="list-style-type: none"> <li><input type="checkbox"/> Develop a culture of working in a team during discussions and experiments.</li> <li><input type="checkbox"/> Develop orderliness in work to present results.</li> <li><input type="checkbox"/> Respect for the procedures in an experiment.</li> <li><input type="checkbox"/> Appreciate the social effects of the misuse alcohols.</li> <li><input type="checkbox"/> Develop self-confidence in the presentation of research work and discussions.</li> </ul>

## Pre-requisite to the unit

Learners have previously looked at the structure and properties of alkanes in Senior 2. They are therefore aware of chemical families of compounds.

Review alkanes as you prepare them for this unit. In this unit, they will learn about the structure and properties of alkenes and alcohols.

## Links to other subjects

During the lessons, strive to bring to the attention of learners the fact that this topic is related to chemicals of life (in Biology) such as fats. Fats fall under category of lipids that are generally soluble in organic solvents and are insoluble in water. Fats can be either liquid (like oil) or solid (like butter) at room temperatures.

## Background Information

Hydrocarbons are organic compounds that are made of hydrogen and carbon atoms only. They are found in many places, including crude oil and natural gas. Learn the different forms of these simple, yet varied, organic compounds.

A hydrocarbon is an organic compound made of nothing more than carbons and hydrogen. It is possible for double or triple bonds to form between carbon atoms and even for structures, such as rings, to form.

Saturated hydrocarbons have as many hydrogen atoms as possible attached to every carbon. For carbons on the end of a molecular chain, three can be attached.

For carbons in the middle of a chain or a ring or two can be attached. For a carbon atom all by itself, four hydrogen atoms can be attached. Saturated hydrocarbons have only single bonds between adjacent carbon atoms.

Unsaturated hydrocarbons have double and/or triple bonds between some of the carbon atoms.

## Cross-cutting issues to be addressed

### 1. Standardisation culture

Bring to the attention of learners the need to check the expiry dates of beverages including alcoholic drinks.

**Note:** Underage drinking is not allowed and so is taking alcohol before required time by Rwanda laws.

### 2. Financial education

Remember that alcoholic drinks generate a lot of money through tax revenues to the government and individuals who invest in beer breweries.

### 3. Gender education

Emphasise to learners that anybody irrespective of their gender should be allowed to participate during teaching and learning processes.

### 4. Inclusive education

All learners should be encouraged to participate during lessons and practical. Special arrangement should be made to take care of learners with special needs. For example, provide braille for blind

learners, large print text for those with sight problems and allocate physically challenged learners to others to assist them during field trips and practical activities. Further, this category should be given tasks that they can manage during the practical sessions.

## Generic competencies

### 1. Research skills

Guide learners on how to find information regarding various topics, on how to come up with summarised notes from a large body of text and on how to do Internet searches for the various content areas they are looking for.

### 2. Communication in English

Communication in English will be improved when learners freely participate in the discussions and presentations. Encourage all learners irrespective of their abilities to participate in group discussions, during presentations by asking questions and during question and answer sessions to either introduce or wrap up the lessons.

### 3. Cooperation and interpersonal management and life skills

During group discussions and pair-work let learners engage one another by giving a chance for all to participate. Also, during group presentations, you can allow rotational presentations within the group members. Gifted learners should help in coming up with presentation content as progressive gradual learners contribute.

**Note:** You should allow progressive gradual learners to do presentations as well and correct them where they go wrong. Advise learners to appreciate the different abilities of their group members and accommodate each other's views.

## 4. Critical thinking and problem solving skills

This competence will be developed by learners as they answer the probing questions at the beginning of this unit and as they discuss the results of the various practical activities. Guide learners to discover for themselves structure and properties of alkenes and alcohols. This competence will also come about as learners think about their findings during the activities and as they give out their suggestions.

### Key words in this unit and their meanings

- *Addition reaction* – organic reaction where two or more molecules combine to form a larger one.
- *Alkene* – hydrocarbons which contain one or more double bonds between carbon atoms.
- *Alcohol* – organic compounds which contain OH attached to saturated carbon atom as functional group.
- *Cracking* – The process of breaking down complex chemical compounds by heating them.
- *Esterification* – reaction between an alcohol and carboxylic acid to form an ester as the only organic compound.

- *Nomenclature* – a system of naming substances.
- *Isomerism* – the occurrence of compounds with same molecular formula but different structural formula.
- *Saturation* – the state of a substance in which the atoms are linked by single bonds. A fully saturated compound contains no double or triple bonds.

### Guidance on the brain teaser

In this topic, you will teach about the structures and properties of alkenes and alcohols. As a way of introducing these concepts, refer learners to the pictures in learner's book.

The pictures show various products made from alkenes and alcohol. Allow learners in groups to discuss the products. The groups should be constituted based on learner abilities and class size. Let them give answers to the probing questions associated with the picture.

Guide the learners to discover what they will learn in this topic. Further, emphasise the need for taking this topic seriously in the course of the lessons as it can lead to environmental awareness.

### Attention to special educational needs

Support for multi ability learning	Support for special needs learning
<ul style="list-style-type: none"> <li>□ Give challenging question to gifted learners (see remedial questions for gifted learners at the end of this.</li> <li>□ For progressive gradual learners organize remedial lessons for them. Guide them through the activities once again to improve their understanding.</li> </ul>	<ul style="list-style-type: none"> <li>□ This unit comprises of numerous activities, you should involve the special need learners in those activities. They should be comfortable when carrying out the activities. They can assist in observation, counting and recording of results. Encourage other learners to accord them the assistance they need.</li> </ul>



## List of lessons

Lesson Number	Lesson title	No. of periods
1	Nomenclature of alkenes and their structures	2
2	Preparation, properties and uses of alkenes	4
3	Nomenclature of alcohols and their structures	2
4	Preparation and properties alcohols	5
5	Uses and misuse of alcohol	1
6	End of unit assessment	1

### 9.1: Nomenclature of alkenes and their structures

*Refer to Learner's Book*

#### Lesson 1: Nomenclature of alkenes and their structures (To be covered in two periods)

##### Specific objectives

By the end of the lesson, learners should be able to:

- Describe the structures of alkenes.
- Name alkenes using IUPAC system.
- Define the term isomerism.
- Write isomers of different simple alkenes such as butene and pentene.

##### Preparation for the lesson

1. This lesson will involve group activities in performing experiments. You will therefore organise the class as need arises during the lesson.

**Note:** When grouping learners, you should consider the different abilities of learners and the special needs for various individuals.

2. Test all experiment apparatus and ensure that they are working before each class session begins. If the apparatus are lacking, you can use the internet (Youtube) to watch the related video and interrogate the learners accordingly.

##### Suggested teaching aids

- Charts with exercises about naming the alkenes for each group.
- Video about naming alkenes or downloaded video on memory card.

##### Introduction to the unit and lesson

Introduce the unit as explained under

guidance brain teaser section above then narrow down to the topic of study.

### Pre-requisite to the unit

Compounds in the same chemical family have similar chemical and physical properties. Learners are aware of this from their study of alkanes.

### Suggested teaching and learning activities

1. (a) Ask probing questions to introduce the lesson. Such questions may include:

- What is an alkane?

(Ans: saturated hydrocarbon)

(b) Name the following alkanes

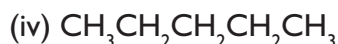
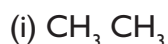

Ans:

(i) Ethane (ii) Propane (iii) Butane

(iv) Pentane

2. Let learners discover the structures of alkenes by instructing them to do Activity 9.1 in the Learner's Book. Inform learners that alkenes and alkanes are different in terms of the presence of double bond in one of the groups. Activity 9.1 should help them. This is a group activity intended to bring out the idea of naming alkenes.

3. Provide learners with the flip chart having rules of naming alkenes, molecular kits and plasticine, let them model structures of various alkenes as shown in the pictures and diagrams. They should suggest names of the alkenes.
4. Let learners discuss about the structures modelled and draw them in their notebooks. They should compare their drawings with other groups in class.
5. Build on the outcome of the activity to discuss the nomenclature of alkenes and their structures as outlined in the Learner's Book. Bring to learners attention table 9.1 in the Learner's Book showing the first five members of alkenes.
6. Introduce learners to the IUPAC naming system for alkenes, take them through the steps and rules involved.
7. Discuss with learners the meaning of isomerism and the two structural isomerism as they take notes. Help learners to summarise the lesson by highlighting the key points in the nomenclature of alkenes.
8. End the lesson by instructing learners to attempt self-evaluation test 9.1.

### Synthesis

The lesson introduces learners to the naming and structure of alkenes and the isomerism in alkenes. The activities carried out during the lesson should

help learners identify the difference in structure of alkenes and alkanes and nomenclature.

### Suggested lesson assessment

Assess whether the learning objectives of the lesson are being met by asking questions such as:

1. What is an alkene?

*Ans: Unsaturated hydrocarbon (double bonds between the carbon atoms)*

2. Can you name the alkenes we have studied today and write their structures.

*Ans: See Learner's Book.*

3. Define isomerism and isomers?

*Ans: the tendency of compounds to exist in different structural formula with but similar molecular formula. Isomers and compounds that exhibit isomerism.*

4. Write the structures of butene and pentene including all their isomers?

*Ans: evaluate each learner's written structures and their isomers and correct accordingly.*

### Answers to Self-evaluation Test

#### 9.1

Refer to Learner's Book

1. a). Butene or But-1-ene

b). 2-methyl propene

2. a)

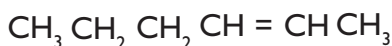

b)

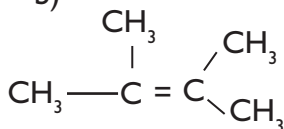

3. a). Compounds with the same molecular formula but a different arrangement of atoms in the molecule which shows different properties.

b). Position isomers are a sub-class of structural isomers and are distinguished by the position of the functional group.

c). (i) Chain isomers



(ii) Position isomers of hexene

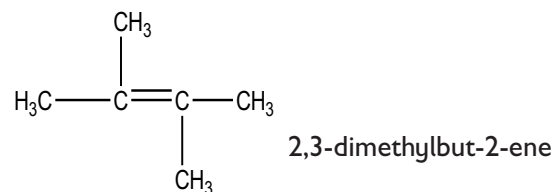
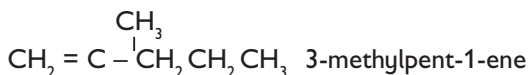
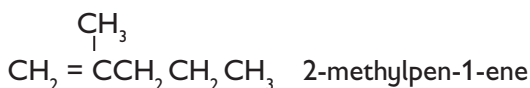

- 4 a. 2,4-dimethylhept-3-ene  
 b. But-2-ene  
 c. 1-pentene or pent-1-ene
5. Double bond, there can never be a double bond in one carbon molecule.
6. a.  $\text{CH}_3\text{CH}=\text{CHCH}_3$   
 b. 
$$\begin{array}{c} \text{CH}_3\text{C} = \text{CH}_2 \\ | \\ \text{CH}_3 \end{array}$$
  
 c. 
$$\begin{array}{c} \text{CH}_3 \\ | \\ \text{CH}_2 = \text{CHC} - \text{CH}_3 \\ | \\ \text{CH}_3 \end{array}$$
7. In saturated hydrocarbons there are only single bonds while in unsaturated hydrocarbons there is presence of at least one carbon-carbon double bond. Unsaturation implies that there is carbon atoms not bonded to the maximum number of atoms can be. For example, alkenes have two fewer hydrogen atoms than the maximum number four.

## 9.2 Preparation, properties and uses of alkenes

*Refer to Learner's Book*

### Lesson 2: Preparation, properties and uses of alkenes (To be covered in four periods)

*Refer to Learner's Book*

#### Specific objectives

By the end of the lesson, learners should be able to:

- Describe and industrial preparation of alkenes.
- Prepare alkenes in the laboratory by dehydrating alcohols.
- Explain the properties of alkenes.
- Describe the chemical test to distinguish between alkenes and alkanes.
- State the uses of alkenes.

#### Preparation for the lesson

1. This lesson will involve laboratory practicals, research activities and group discussions. You will therefore organise the class as need arises during the lesson.

**Note:** When grouping learners, you should consider the different abilities of learners and the special needs for various individuals.

3. Test all experiment apparatus and ensure that they are working before the lesson begins.
4. If the apparatus is lacking, you can use the internet to let learners watch the video showing preparation properties and uses of alkenes.

#### Suggested teaching aids

- Charts showing the arrangement of the apparatus and the procedure for each group, preparation of alkenes, properties of alkenes and their uses.

#### Pre-requisite to the unit

Learners are already aware of experiment procedures and handling of

apparatus. This skill will help them during this lesson.

### **Suggested teaching and learning activities**

#### **A. Sources of alkenes**

1. Begin the lesson by telling learners that there are two sources of alkenes i.e. dehydration of alcohols and cracking of hydrocarbons. You will tackle each separately.
2. Organise learners into convenient group size according to availability of resources to carry out Activity 9.2 in the Learner's Book.
3. Guide learners in setting up the apparatus and assist them during the experiment. Instruct them to follow the procedure as laid down in the Learner's Book.
4. After the experiment let them discuss their observations and findings after which they will do a presentation in class. Instruct learners to always make proper observations, record the results of the experiment.
5. Build on their presentations to explain how hydrolysis of alcohols takes place to form alkenes as outlined in the Learner's Book as they take notes.
6. Thereafter discuss with learners how cracking of hydrocarbons takes place in industries as outlined in the Learner's Book.
7. Help learners to summarise the lesson by highlighting the key points on sources of alkenes.

#### **B. Properties of alkenes**

1. In this lesson learners will learn about the physical and chemical properties of alkenes.
2. Provide learners with charts on trends of physical and chemical properties of alkenes for them to discuss in pairs. They should observe the trends and come up with conclusions which they will compare with others in class.
3. Thereafter take learners through the physical and chemical properties of alkenes as outlined in the Learner's Book.
4. Make learners understand the various chemical reactions involving alkenes, use equations and diagrams to illustrate this.
5. In Activity 9.3 in the Learner's Book, learners will carry out an experiment to test for unsaturation. Organise them into groups to do this activity. They should note their observations carefully and record them in their note books.
6. From their findings, explain the test for unsaturation as you compare it with that for alkanes. Ask learners to name uses of alkenes, from their responses discuss the uses of alkenes as outlined in the Learner's Book.
7. Help learners to summarise the lesson by highlighting the key points of properties and uses of alkenes.

8. End the lesson by instructing learners to attempt self-evaluation test 9.2.

### Synthesis

This lesson introduces learners to preparation of alkenes. Use the experiments to describe how different alkenes can be prepared in the laboratory.

### Suggested lesson assessment

Assess whether the learning objectives of the lesson were met by asking questions such as:

1. What would happen if an alkene and alkane were both passed separately through bromine water?

*Ans: With an alkene bromine water would be decolorised and no observable change with an alkane.*

2. State any two uses of alkenes.

*Ans: Manufacture of plastics, industrial chemicals.*

### Answers to Self-evaluation Test 9.2

Refer to Learner's book

1. The alkene at 25°C is liquid because at any temperature above -140°C but less than 64°C the alkene is liquid.

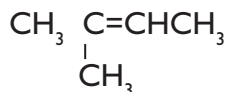
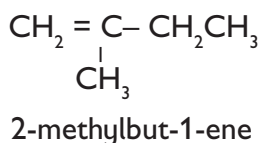
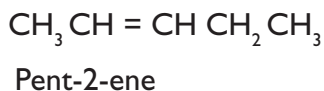
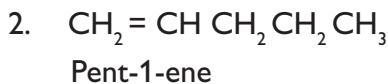

2-methylbut-2-ene

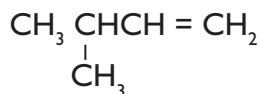

3-methylbut-1-ene

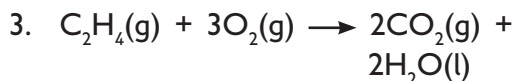

4. Refer to Learner's Book

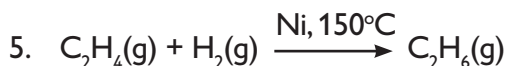
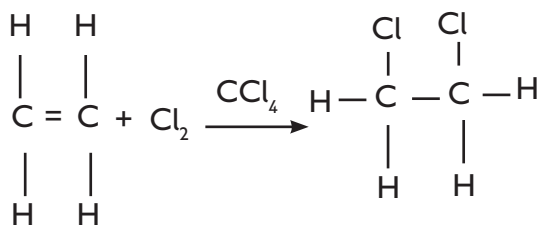

### 9.3 Nomenclature of alcohols and their structures

Refer to Learner's Book

#### Lesson 2: Nomenclature and characteristics of alkenes and their structures (To be covered in two periods)

#### Specific objectives

By the end of the lesson, learners should be able to:

- Describe the structures of alcohols
- Name alcohols using IUPAC system.
- Explain the characteristics of alcohol.

#### Preparation for the lesson

1. This lesson will involve group activities. You will therefore organise the class as is necessary for the lesson.

**Note:** When grouping learners, you should consider the different abilities of learners and the special needs for various individuals.

2. Provide the procedure for the activity or a chart showing how to model.
3. Bring all experiment apparatus and ensure that they are working before the lesson begins. In case the apparatus are lacking, you can use the internet to watch the video showing experiment on how temperature affects the rate of reaction.
4. Also, ensure that the Internet is working if you have a computer laboratory or any other form of internet connectivity such as WIFI or modem. This should be done in advance to check the relevant video as well.

### **Suggested teaching aids**

- Charts containing structures of various alcohols and their names.
- Video link to the learners about naming alcohols or downloaded video on memory stick.

### **Pre-requisite to the unit**

Compounds in same chemical family have similar structure and a general formula. Using the formula, learners can be able to predict the next alcohol in the series.

### **Suggested teaching and learning activities**

1. Let learners discover the structures of alcohols by discovery by giving them Activity 9.4 in the Learner's Book.
2. Inform them that alcohols have the same structure like alkanes but with addition of the functional group -OH. Let them compare the structures of alcohols and alkanes.
3. This is a group activity intended to bring out the idea of naming alcohols.
4. Provide learners with the flip chart having rules of naming alcohol, molecular kits and plasticine, let them model structures of various alcohol as shown in the pictures and diagrams. They should suggest names of the alcohols.
5. Let them discuss the structures modelled and draw them in their notebooks. They should compare their drawings with those of other groups.
6. Build on their findings to discuss the nomenclature of alcohols and their structures as outlined in the Learner's Book.
7. Bring to learners attention table 9.3 in the learners book showing the first five members of alcohols.
8. Introduce learners to the IUPAC naming system for alcohols, take them through the steps and rules involved.

9. Discuss with learners the structural isomerism of alcohols as they take notes.
10. Help learners to summarise the lesson by highlighting the key points in the nomenclature and characteristics of alcohols.

### Synthesis

The lesson introduces learners to the naming and structure of alcohols and their isomerism. The activities carried out during the lesson should help learners identify the difference in structure of alkenes and alkanes and alcohols.

### Suggested lesson assessment

Assess whether the learning objectives of the lesson are being achieved by asking questions such as:

- (a) Write the structures of alcohols up to carbon-6.
- (b) Give the names of the alcohols in (a) above

### Preparation and properties of alcohols

#### Lesson 3: Preparation, properties and uses of alcohols (To be covered in six periods)

*Refer to Learner's Book*

#### Specific objectives

By the end of the lesson, learners should be able to:

- Describe laboratory preparation of alcohol.

- Describe the physical and chemical properties of alcohols.

### Preparation for the lesson

1. This lesson will involve group activities to perform experiment. You will therefore organise the class as need arises during the lesson.

**Note:** When grouping learners, you should consider the different abilities of learners and the special needs for various individuals.

2. Provide the experiment procedure and chart showing arrangement of the apparatus to the learners.
3. Bring all experiment apparatus and ensure that they are working before the lesson begins.
4. If the apparatus are lacking, you can use the internet to watch the video on preparation of alcohol.
5. Also, ensure that the Internet is working if you have a computer laboratory or any other form of internet connectivity such as WIFI or modem. This should be done in advance to check the relevant video as well) video watching will be carried out.

### Suggested teaching aids

- Charts showing the arrangement of the apparatus and the procedure for each group, preparation of alcohols, properties of alcohols and their uses.
- Video link to the learners (use you tube.com).
- Learner's test book.



## Improvisation

Where there are no commercial charts, standard laboratory apparatus you may come up with your own.

## Pre-requisite to the unit

Learners should learn to respect procedures in an experiment and record their observations accurately.

## Suggested teaching and learning activities

### A. Preparation of alcohols

1. Begin the lesson by telling learners that there are two methods of preparing alcohols i.e. hydrolysis of alkenes and fermentation of carbohydrates. You will tackle each separately.
2. Organise learners into convenient groups according to availability of resources to carry out Activity 9.5 in the learner's text book.
3. Guide learners in setting up the apparatus and assist them during the experiments. Instruct them to follow the procedure as laid out in the experiments.
4. After the experiment let them discuss their observations and findings after which they will do a presentation in class.
5. Let the learners make proper observations, record the results from the experiment.

6. Build on their presentation to explain how fermentation of glucose takes place to form alcohols as outlined in the learner's book as they take notes.
7. Thereafter discuss with learners how hydrolysis of alkenes takes place to form alcohols.
8. Help learners to summarise the lesson by highlighting the key points on preparation of alcohols.
9. Instruct learners to attempt self – evaluation Test 9.3.

### B. Properties of alcohols

1. In this lesson learners will learn about the physical and chemical properties of alkenes.
2. Provide learners with charts on trends of physical and chemical properties of alcohols for them to discuss in pairs.
3. They should observe the trends and come up with conclusions which they will compare with others in class.
4. Introduce Activity 9.6, in the Learner's Book where learners will investigate physical properties of ethanol.
5. Organise learners into convenient groups according to availability of resources to carry out Activity 9.6 .
6. Guide learners in setting up the apparatus and assist them during the experiments. Instruct them to

- follow the procedure as laid down in the experiment.
- After the experiment let them discuss their observations and findings after which they will do a presentation in class.
  - Let the learners make proper observations, record the results of the experiment.
  - Build on their presentation to explain the physical properties of alcohols as outlined in the Learner's Book as they take notes.
  - Bring to learner's attention table 9.4 showing a summary of the physical properties of alkanols.
  - Instruct learners to attempt self-evaluation test 9.4.
  - Introduce Activity 9.7 in the Learner's Book, where learners will investigate fermentation of sugar.
  - Instruct learners to carry out the activity as outlined in the Learner's Book. Let the groups compare their results.
  - Thereafter introduce chemical properties of alcohol with activity 9.8 as outlined in the Learner's Book. Let learners in their respective groups carry out the activity and note their observations in a table format as suggested in table 9.5.
  - They should discuss their observations and make report which they will present in class.
  - Build on their presentation to explain the chemical properties of alcohol as outlined in the learner's book as they take notes.
  - Emphasise on the equations involved. They should learn to write well balanced equations.
  - Help learners to summarise the lesson by highlighting the key points of preparation and properties of alkenes.

### Synthesis

This lesson introduces learners to physical and chemical properties of alcohols. The experiments help to investigate some of the physical properties such as solubility, boiling temperatures.

### Suggested lesson assessment

Assess whether the learning objectives of the lesson were met by asking questions such as:

- Describe how boiling points of alcohols vary as the number of carbon atoms increases.

*Ans: Increases with increase in their molecular mass*

- Comment on the effect of alcohols on litmus paper.

*Ans: neutral to litmus (neither acidic nor basic)*

## Answers to Self-evaluation Test

### 9.3

Refer to Learner's book

- (a) They are derived from an alkane by replacing one of the hydrogen atoms with a  $-OH$  group. Their general formula is  $C_nH_{2n+1}OH$ .  
(b) Refer to learner's book
- $C_nH_{2n}$
- Methanol
  - Propanol
  - Pentanol
  - Ethanol
  - Butanol
- Methyl, propyl, pentyl, ethyl, butyl alcohol respectively.
- Refer to the learner's book.
- Carbon dioxide
- Refer to learner's book

## Answers to Self-evaluation Test 9.4

Refer to Learner's book

- colourless, soluble in water, do not conduct electricity, no effects on litmus paper
- Increase with increase in molecular weight.
- Refer to activity 9.6 in the learners.

## 9.4 Uses and misuse of alcohol

### Lesson 5: Uses and misuse of alcohol (To be covered in one period)

Refer to Learner's Book

#### Specific objectives

By the end of the lesson, learners should be able to describe the social, biological and economic effects of alcohol and its abuse.

#### Preparation for the lesson

- This lesson will involve a research activity either in the library or use the Internet or group work.
- Discussion and presentation of research work.
- Also, ensure that the internet is working if you have a computer laboratory or any other form of internet connectivity such as WIFI or modem.
- The teacher should guide the learners how to access the relevant information using google, books or any written pamphlets.

#### Suggested teaching aids

- Charts on various social, biological and economic effects of alcohol abuse.
- Learners Book

#### Improvisation

Make notes on social, biological and economic effects of alcohol abuse.

### Pre-requisite to the lesson

Learners should appreciate the social effects of the misuse of alcohol, as well as its importance.

### Suggested teaching and learning activities

1. Let learners go to the library and research from textbooks and internet on how alcohol consumption affect the social, economic and biological factors of human life.
2. Back in class, put learners in groups of five depending on the size of the class to harmonize their findings. Let them choose a group leader to do a presentation to the rest of the class.
3. After the presentations, guide learners to write short notes on effects of alcohol abuse as outlined in the Learner's Book.
4. Help learners to summarise the lesson by writing short notes on uses and misuse of alcohol.
5. End the lesson by instructing learners to attempt self-evaluation 9.5 and Test your competence 9.

### Synthesis

This lesson introduces the behavioral effects of alcohol abuse and misuse to help them discover and appreciate all aspects of alcohol misuse in the society.

### Suggested lesson assessment

Assess whether the learning objective of the lesson was met by asking questions such as:

1. Describe how alcohols consumption can affect the economic, social and biological factors of human life.

*Ans: Refer to learners book.*

### Answers to Self-evaluation Test 9.5

*Refer to Learner's book*

1. Bromine, orange, decolourises, ethane, ethene.
- 2.

Ethanol	One of the product of glucose fermentation.
Saturated	Organic compounds containing only single bond.
Unsaturated	Organic compound containing C = C bond.
Addition	A reaction in which two or more compounds react to form only one compound.
Cracking	The breaking down of long chain alkanes to alkenes and short chain alkanes.

3. a. Addition of bromine water to both alkane and alkene. In the case where there is colour change that compound is ethene (alkene)  
b. Ethane :  $\text{CH}_3\text{-CH}_3$   
Ethene :  $\text{CH}_2=\text{CH}_2$

c. i. Phosphoric acid catalyst and temperatures of 300°C and 60 atm.

ii. Fermentation of sugars

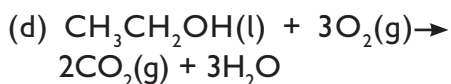

### Summary of the unit

This unit describes the structure and properties of alkenes and alcohols.

Let the learners carry out activities and practice drawing the structures of alkenes and alcohols.

Make the learners aware of the uses and misuses of alcohols and alkenes in daily life.

Ensure that learners develop a culture of working as a team during discussions and experiments.

Instill self confidence in the learners as they do presentations of the research work.

### Additional Information for the teacher

#### A. Saturation

Saturation refers to the number of double bonds present in the hydrocarbon tail. Some fats have no double bonds and have the maximum number of hydrogen atoms attached to the hydrocarbon tail. Also known as saturated fats, these fatty acids are straight in structure and tightly packed together to form a solid at room temperature.

Saturation also determines the physical state and melting points of the fatty acids. For instance, while saturated fats are solids, due to their structure at room temperature, unsaturated fats, such as oils, have bends in their hydrocarbon tails from double bonding in their carbon-to-carbon bonds. The bends cause the oils to be liquids or semi-solids at room temperature. Therefore, saturated fats have higher melting points due to the straight structure of their hydrocarbon tails. Double bonds in unsaturated fats make them easier to break down at lower temperatures.

#### B. Isomerism

Isomerism is the phenomenon whereby certain compounds, with the same molecular formula, exist in different forms owing to their different organisations of the atoms. The concept of isomerism illustrates the fundamental importance of molecular structure and shape in organic chemistry.

**Stereoisomers** have the same structure and bond order but their atoms and groups of atoms are arranged differently in space. They have different spatial arrangements and their molecules are not superimposable.

Structural or constitutional isomerism involves isomers having the same atoms but in different arrangements. For example, dimethyl ether,  $\text{CH}_3\text{OCH}_3$  and ethanol,  $\text{CH}_3\text{CH}_2\text{OH}$  both have the same simple molecular formula:  $\text{C}_2\text{H}_6\text{O}$ . Structural isomerism is of five types:

□ Chain isomers have same molecular formula but differ in the order in

which C-atoms are bonded to each other.

- Position isomerism – Isomerism caused by the difference in the position of functional group in the same chain.
- Functional isomers – have same molecular formula but different functional group.
- Metamerism – This type of isomerism is due to the unequal distribution of carbon atoms on either side of functional group. Metamerism belongs to same homologous series.
- Tautomerism – It is a special type of functional isomerism in which the isomers are in dynamic equilibrium with each other.

### **C. Social and economic problems are linked to alcohol use**

Alcohol consumption can have adverse social and economic effects on the individual drinker, the drinker's immediate environment and society as a whole. Indeed, individuals other than the drinker can be affected, for example, by traffic accidents or violence. It has an impact on society as a whole in terms of resources required for criminal justice, health care and other social institutions. Alcohol consumption can affect work performance in several ways:

- Absentism from work.
- Work accidents
- Productivity - Heavy drinking at work may reduce productivity.

□ Drinking can impair how a person performs as a parent, a partner as well as how one contributes to the functioning of the household. It can have lasting effects on their partner and children, for instance through home accidents and violence.

□ Children can suffer Fetal Alcohol Spectrum Disorders (FASD), when mothers drink during pregnancy. After birth, parental drinking can lead to child abuse and numerous other impacts on the child's social, psychological and economic environment.

The impact of drinking on family life can include substantial mental health problems for other family members, such as anxiety, fear and depression.

Drinking outside the home can mean less time spent at home. The financial costs of alcohol purchase and medical treatment, as well as lost wages can leave other family members destitute. When men drink it often primarily affects their parents or partners who may need to contribute more to the income of the household. The drunkards also run an increased risk of violence or HIV infection

### **Answers to Test your Competency 9**

*Refer to Learner's*

1. Oxygen addition is involved.
2. Absentism, accidents, loss of employment, social stress to the family members, low productivity at work.

3. i. Hydrogen gas effervescence is produced.
- ii. Production of manganese (IV) oxide, acetaldehyde, potassium hydroxide and water.
4.  $C_3H_6, C_2H_2$
5. Saturated hydrocarbons burn with a clean flame while unsaturated hydrocarbons burn with a sooty flame when burnt in air.
6. Ethanol is oxidized to ethanoic acid (Refer to Learner's Book)
7. a. A - Nickel  
B - Ethane  
C - Carbon dioxide  
D - Phosphoric acid  
E - Ethanol  
F - 1,2-dibromoethane
- b. Ethene + steam  $\rightarrow$  ethanol
- c. Alkanes
- d. Passing it through lime water, if turns cloudy. This is a confirmatory test.
8. A                      9. B
10. C                     11. C
12. C                     13. B
14. A and D                15. D
16. B                     17. A
18. A                     19. C
20. B

**(b) Additional exercises for unit assessment (Consolidation exercises)**

1. (a) Give a chemical test to distinguish between saturated and unsaturated hydrocarbons

- (b) (i) Name the product formed when ethanol burns in the air.
- (ii) What two forms of energy are liberated on burning alcohol?
- c. Why is the reaction between methane and chlorine considered a substitution reaction?

**Answer**

- (a) Add bromine water. Saturated hydrocarbons do not react whereas unsaturated hydrocarbon will decolourise bromine water.
- (b) (i)  $CO_2$  and  $H_2O$ .
- (ii) Heat energy and light energy.
- (c) It is because 'Cl' atom substitutes 'H' atom of methane to chloromethane and hydrogen chloride.

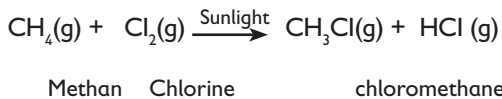

2. Give reasons for the following observations:
  - (a) The element carbon form a very large number of compounds.
  - (b) Air holes of a gas burner have to be adjusted when the heated vessel get blackened by the flame.
  - (c) Use of synthetic detergent causes pollution of water.
3. Write the name and molecular formula of an organic compound that has its name suffixed with -ol and having two carbon atoms in the molecule. With

the help of a balanced chemical equation indicate what happens when it is heated with excess of concentrated sulphuric acid.

### Answer

It is ethanol, its molecular formula is  $C_2H_5OH$

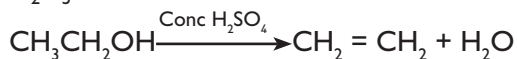

Ethanol

Ethene

4. What is a homologous series? Which two of the following organic compound

belong to the same homologous?

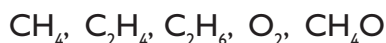

### Answer

Homologous series is a series of organic compound which have same functional group and similar chemical properties. Each member of series differs by  $-CH_2-$  in its molecular formula.

$CH_4$  and  $C_2H_6$  belong to same homologous series.

## Extended and remedial exercises

Remedial activities for slow learners	Extended activities for gifted and talented learners
<ol style="list-style-type: none"> <li>1. Collecting, cleaning and arranging apparatus and reagents in the laboratory.</li> <li>2. Collect various materials and objects at home for experiments.</li> <li>3. Drawing diagrams from charts on their notebooks.</li> </ol> <p><b>Low order thinking (LOT) questions for slow learners</b></p> <ol style="list-style-type: none"> <li>1. What is a double bond?</li> <li>2. Name two sources of alkenes.</li> <li>3. What are the characteristics of alcohols?</li> </ol> <p><b>Answers Low order thinking questions</b></p> <ol style="list-style-type: none"> <li>1. a chemical bond in which two pairs of electrons are shared between two carbon atoms.</li> <li>2. Dehydration of alcohols, cracking of alkenes.</li> <li>3. Contain <math>-OH</math> group to a carbon atom singly bonded.</li> </ol>	<ol style="list-style-type: none"> <li>1. Do further research from textbooks or the internet about carbon and its inorganic compounds. Write short notes then share with other class members.</li> <li>2. Set up apparatus for practicals in the laboratory.</li> <li>3. Come up with a project and make a device for making fermenting sugars. Use locally available materials and make the item.</li> </ol> <p><b>High order thinking (HOT) questions for gifted learners</b></p> <ol style="list-style-type: none"> <li>1. Why is the melting point of alkenes very low?</li> <li>2. What conditions are required for polymerisation of ethene to take place?</li> <li>3. Yeast plays a major role during fermentation of alcohol. Name the role.</li> </ol> <p><b>Answers to high order thinking questions</b></p> <ol style="list-style-type: none"> <li>1. They contain double bonds which are weak.</li> <li>2. High pressure and temperature.</li> <li>3. Yeast contain enzymes that break down carbohydrates into glucose.</li> </ol>



*Refer to learner's book*

## Key Unit Competence

After studying this unit, learner should be able to explain the properties of carboxylic acids.

## Learning objectives

Competency based curriculum embraces three categories of learning objectives,

that is, knowledge and understanding, skills acquisition and attitude and values. At the end of the unit, learners should have knowledge and understanding of the properties and structure of carboxylic acids. Appreciate the importance of carboxylic acids in everyday life.

**Table 10.1: Knowledge, skills and values to be attained**

Knowledge and understanding	Skills	Attitudes and values
<ul style="list-style-type: none"> <li><input type="checkbox"/> Define a carboxylic acid.</li> <li><input type="checkbox"/> Name and write the structures of some carboxylic acids up to C-5.</li> <li><input type="checkbox"/> Explain the preparation of carboxylic acids from oxidation of alcohols.</li> <li><input type="checkbox"/> State the physical properties of some carboxylic acids.</li> <li><input type="checkbox"/> Explain the chemical reactions of carboxylic acids.</li> <li><input type="checkbox"/> Explain the reduction of carboxylic acids as a method of preparing alcohols on small scale.</li> </ul>	<ul style="list-style-type: none"> <li><input type="checkbox"/> Observation skills.</li> <li><input type="checkbox"/> Manipulation of equipment.</li> <li><input type="checkbox"/> Research and presentation skills.</li> <li><input type="checkbox"/> Write the structures of different carboxylic acids and equations.</li> <li><input type="checkbox"/> Carry out experiments to show how carboxylic acids react with other substances.</li> </ul>	<ul style="list-style-type: none"> <li><input type="checkbox"/> Develop culture of entrepreneurship.</li> <li><input type="checkbox"/> Develop a culture of working in a team.</li> <li><input type="checkbox"/> Develop orderliness in presentations and experiments.</li> <li><input type="checkbox"/> Respect for the procedures of an experiment.</li> </ul>

## **Pre-requisite to the unit**

Carboxylic acids, just like alkenes and alcohols are chemical families. Their properties chemical and structure are similar with the group.

Learners have learnt about chemical families, review their knowledge as you prepare them for this unit.

During the lessons, strive to bring to the attention of learners the fact that this topic is related chemical of life such as proteins, carbohydrates and amino acids.

## **Background Information**

Carboxylic acids are a group of important organic chemicals. Vinegar contains ethanoic acid, which is a carboxylic acid. All carboxylic acids have a  $\text{-COOH}$  as functional group, and have similar chemical properties as a result. They are weak acids because this functional group is only partly ionised in solution.

## **Cross-cutting issues to be addressed**

### **1. Inclusive learning**

All categories of learners should be encouraged to participate during lessons and experiments. Make arrangements to take care of learners with special needs. In particular learners for the blind if possible should be placed in front of the classroom. Provide braille for learners with visual impairment and large print text for those with sight problems.

Group physically challenged learners with the other learners to assist them during movement and field trips and other practical activities. Furthermore,

give these learners tasks they can manage during practical.

### **2. Gender education**

Both boys and girls should participate equally in all activities. Emphasise to learners that anybody irrespective of their gender can pursue a career in this chemistry related field. Give examples of role models who are successful in their careers locally.

### **3. Financial education**

Carboxylic acids are used as components of many products we use at home. These have financial implications in terms of cost.

### **4. Standardisation culture**

Emphasise the need to use chemicals and apparatus certified by the Rwandan Bureau of Standards.

### **5. Peace and values education**

Emphasise to learners the importance of working harmoniously with each other during group work and class activities.

### **6. Health education**

Emphasise to learners that some carboxylic acids are dangerous. They should take caution when handling them.

## **Generic competencies**

### **1. Research skills**

Guide learners on how to find information regarding carboxylic acids, on how to come up with summarised notes from a large body of text and on how to do

internet searches for the various content areas they are looking for.

## 2. Communication in English

Communication in English will be improved when learners freely participate in the discussions and presentations. Encourage all learners irrespective of their abilities to participate in group discussions, during presentations by asking questions and during question and answer sessions to either introduce or wrap up the lessons.

## 3. Cooperation and interpersonal management and life skills

During group discussions and pair-work let learners engage one another by giving a chance for all to participate. Also, during group presentations, you can allow rotational presentations within the group members. Gifted learners should help in coming up with presentation content as progressive gradual learners contribute.

**Note:** You should allow progressive gradual learners to do presentations as well and correct them where they go wrong. Advise learners to appreciate the different abilities of their group members and accommodate each other's views.

## 4. Critical thinking and problem solving skills

This competence will be developed by learners as they answer the probing questions at the beginning of this unit and as they discuss the results of the various practical activities. Guide learners to discover for themselves – properties and uses of carboxylic acids.

This competence will also come about as learners think about their findings in the activities and as they give out their suggestions.

### Key words in this unit and their meanings

- **Carboxyl groups** – weak acids, dissociating partially to release hydrogen ions.
- **Alkene** – hydrocarbons which contain one or more double bonds between carbon atoms.
- **Alcohol** – organic compounds which contain -OH attached to saturated carbon atom as functional group.
- **Esterification** – the reaction between an alcohol and carboxylic acid to form an ester as the only organic compound.

### Guidance on the brain teaser

In this topic, you will teach about carboxylic acids. As a way of introducing these concepts, refer learners to the pictures on the Learner's Book. The pictures show various products that contain acids and bases. Allow learners in groups to discuss the products. The groups should be constituted based on learner abilities and class size. Let them give answers to the probing questions associated with the picture.

Guide the learners to discover what they will learn in this topic. Further, emphasise the need for taking this topic seriously in the course of the lessons as it can lead to environmental awareness.

## Attention to special educational needs

Support for multi-ability learning	Support for special needs learning
<ul style="list-style-type: none"> <li><input type="checkbox"/> Gifted learners to research on the reaction of carboxylic acids and assist slow learners during experiment.</li> <li><input type="checkbox"/> Both gifted and progressive gradual learners to be given equal opportunity to lead in group discussions and to do presentations of group findings to the rest of the class.</li> <li><input type="checkbox"/> Ensure all learners respect each other's views irrespective of their shortcomings or talents.</li> </ul>	<ul style="list-style-type: none"> <li><input type="checkbox"/> Allocate gifted learners to help fellow learners with special needs.</li> <li><input type="checkbox"/> Provide brail for blind learners and large print text to learners with seeing difficulties. Provide sign language alphabet symbols and sign language interpreters for the deaf.</li> <li><input type="checkbox"/> Also, arrange learners such that shortsighted ones are at the front and long-sighted ones are at the back. Spectacles can as well be provided if available for learners with seeing difficulties.</li> </ul>

## List of lessons

Lesson Number	Lesson title	No. of periods
1	General formula and nomenclature of carboxylic acid	2
2	Preparation of carboxylic acids	1
3	Properties and uses of carboxylic acids	2
4	End unit assessment test	1

### 10.1 General formula and nomenclature of carboxylic acids

#### Lesson 1: General formula and nomenclature of carboxylic acids (To be covered in two periods)

Refer to learner's book

#### Specific objectives

By the end of the lesson, learners should be able to

- Define carboxylic acid.

- Name and write the structures of some carboxylic acids.

#### Preparation for the lesson

1. This lesson will involve group work and experiment. You will therefore organise the class as need arises during the lesson.

**Note:** When grouping learners, you should consider the different abilities of learners and the special needs for various individuals.

2. Guide learners through the experiment procedure and arrangement of the apparatus to the learners.
3. Test all experiment apparatus and ensure that they are working before the lesson begins.
4. Also, ensure that the internet is working if you have a computer laboratory or any other form of internet connectivity such as WIFI or modem. This should be done in advance to check the relevant video as well.

### Suggested teaching aids

- Charts with diagrams on naming carboxylic acids.
- Video link to the learners.
- Learner's Book.

### Pre-requisite to the unit and lesson

Introduce the unit as explained under guidance on the brain teaser section then narrow down to the lesson.

### Suggested teaching and learning activities

1. Remind learners of previous homologous series covered i.e. alkanes, alkenes and alcohols. They should now be able to appreciate the structures and naming of carboxylic acids as homologous series.
2. Let learners discover the structures of carboxylic acids by performing Activity 10.1 in the Learner's Book. Inform them that alkenes and alkanes are different in terms of the double bond in carbon atoms while

alcohols and carboxylic acids differ in the functional groups. Let them compare and discover the difference as they do activity 10.1.

This is a group activity intended to bring out the idea of naming of carboxylic acids.

3. Provide learners with the flip chart having rules of naming carboxylic acids, molecular kits and plasticine, let them model structures of various carboxylic acids aided by the pictures and diagrams. They should suggest names of the acids modelled.
4. Let them discuss the structures of the acids modelled and draw them in their notebooks. They should compare their drawings with other groups in class.
5. Build on their findings to discuss the nomenclature of carboxylic acids and their structures as outlined in the Learner's Book. Bring to learners attention table 10.1 in the learners book showing the first five members of carboxylic acids.
6. Introduce learners to the IUPAC naming system for carboxylic acids, take them through the steps and rules involved.
7. Help learners to summarise the lesson by highlighting the key points in the nomenclature of carboxylic acids.

8. End the lesson by instructing learners to attempt self –evaluation test 10.1.

### Synthesis

The lesson introduces learners to the nomenclature and structure of carboxylic acids. The activities carried out during the lesson should help learners identify the structure in carboxylic acids.

### Suggested lesson assessment

Assess whether the learning objectives of the lesson are being met by asking questions such as:

1. What are carboxylic acids?

*Ans: A homologous series of organic compounds that contain the same functional group  $-COOH$  (carboxylic group)*

2. Give two characteristics of carboxylic acids.

- They turn blue litmus paper red.
- They have higher melting and boiling points than most of other organic compounds.
- Most carboxylic acids are solids at room temperature.

### Answers to Self-evaluation Test

#### 10.1

*Refer to Learner's Book*

1.  $-COOH$
2. Hexa-, hepta-, octa-, nona-, deca- noic acid.

## 10.2 Preparation of carboxylic acids

*Refer to Learner's Book*

### Lesson 2: Preparation carboxylic acids (To be covered in one period)

*Refer to Learner's book*

### Specific objectives

By the end of the lesson, learners should be able to describe the preparation of carboxylic acids.

### Preparation for the lesson

1. This lesson will involve group discussion. You will therefore organise the class as need arises during the lesson.

**Note:** When grouping learners, you should consider the different abilities of learners and the special needs for various individuals.

2. Also, ensure that the internet is working if you have a computer laboratory or any other form of internet connectivity such as WIFI or modem. This should be done in advance to check the relevant video as well).

### Suggested teaching aids

- Charts on preparation of carboxylic acids.
- Video link to the learners ( use you tube.com)
- Learner's Book

### Pre-requisite to the lesson

Learners should develop orderliness

in presentation and during group discussion.

### Suggested teaching and learning activities

1. Begin the lesson by pairing learners to do a discussion on the preparation of carboxylic acid as outlined in the Learner's Book. By now they should be able to relate preparation of other homologous series to carboxylic acids.
2. Ask each pair to present its findings. Use their findings to explain preparation of carboxylic acid as outlined in the Learner's Book as they take notes. Use charts, diagrams and equations to illustrate this reactions during the preparations. Let learners appreciate the need to respect procedure during practical activities and appreciate development of team work in group activities.
3. At this point you can give a summary of preparation of carboxylic acids.
4. Instruct learners to attempt questions in Self-evaluation Test 10.2.

### Synthesis

This lesson introduces learners to preparation of carboxylic acids. The research activity or discussion carried out during the lesson will help learners appreciate the significance and importance of carboxylic acids.

### Suggested lesson assessment

Assess whether the learning objectives of the lesson were met by asking the

following questions:

1. Which chemical substance is used to oxidise an alcohol in preparation of alkanolic acids.

*Ans: Acidified potassium dichromate (IV) or acidified potassium manganate (VII).*

### Answers to Self-evaluation Test 10.2

*Refer to Learner's book*

1. Acidified potassium dichromate (VI) or acidified potassium manganate (VII) and butanol.
2. Refer to Learner's Book

### 10.3 Properties and uses of carboxylic acids

*Refer to Learner's Book*

#### Lesson 3: Properties and uses of carboxylic acids (To be covered in three period)

*Refer to Learner's Book*

#### Specific objectives

By the end of the lesson, learners should be able to describe properties and uses of carboxylic acids.

#### Preparation for the lesson

1. This lesson will involve group work, discussion and experiments. You will therefore organise the class as need arises during the lesson.

**Note:** When grouping learners, you should consider the different abilities of learners and the special needs for various individuals.

2. Guide learners through the

experiment procedure and in arranging of the apparatus.

3. Test all experiment apparatus and ensure that they are working before the lesson begins.
4. Also, ensure that the Internet is working if you have a computer laboratory or any other form of internet connectivity such as WIFI or modem. This should be done in advance to check the relevant video as well).

### **Suggested teaching aids**

- Charts showing the properties and uses of carboxylic acids.
- Video link to the learners
- Learner's Book

### **Suggested teaching and learning activities**

1. Provide learners with charts on trends of physical and chemical properties of carboxylic acids for them to discuss in pairs. They should observe the trends and come up with conclusions which they will compare with others in class.
2. Build on their presentations to explain the physical properties of carboxylic acid as outlined in the Learner's Book as they take notes. Bring to learners attention table 10.2 showing a summary of the physical properties of carboxylic acid.
3. Introduce Activity 10.2, where learners will investigate chemical properties of ethanoic acid. Organise

learners into convenient groups according to availability of resources to carry out Activity 10.2 in the Learner's Book . Guide learners in setting up the apparatus and assist them during the experiments. Instruct them to follow the procedure as laid down in the experiments.

4. After the experiment let them discuss their observations and findings after which they will do a presentation in class.
5. Build on their presentations to explain the chemical properties of carboxylic acid as outlined in the Learner's Book as they take notes. Emphasise on the equations involved. They should learn to write well balanced equations.
6. Discuss with learners the uses of ethanoic acids as they take notes.
7. Help learners to summarise the lesson by highlighting the key points of physical and chemical properties of carboxylic acids.
8. Organise a field trip to a soap manufacturing factory as suggested in Activity 10.3. Let learners prepare questionnaire which they will use to ask questions. Instruct them to prepare a report which they will discuss in groups and present in class.
9. End the lesson and topic by instructing learners to attempt Self –evaluation Test 10.3 and Test your



## Competence 10.

### Synthesis

This lesson introduces learners to physical and chemical properties of carboxylic acids. Use the experiments to investigate and describe different physical properties of carboxylic acids such as solubility, boiling points, action on litmus paper etc.

### Suggested lesson assessment

Assess whether the learning objectives of the lesson are being met by asking questions such as:

1. Name uses of ethanoic acids.

*Ans: Making vinegar, a laboratory reagent, preparation of dyes, perfumes and some medicines' ingredients.*

2. State the physical properties of carboxylic acids.

*Ans: Liquid at room temperature, boiling and melting points increase gradually.*

### Answers to Self-evaluation Test 10.3

Refer to Learner's Book

1. a) Ethyl methanoate.  
b)  $\text{HCOOH} + \text{CH}_3\text{CH}_2\text{OH} \rightarrow \text{HCOOCH}_2\text{CH}_3 + \text{H}_2\text{O}$
2. a)  $2\text{K(s)} + 2\text{C}_2\text{H}_5\text{COOH(aq)} \rightarrow 2\text{C}_2\text{H}_5\text{COOK(aq)} + \text{H}_2\text{(g)}$   
b)  $\text{CH}_3\text{COOH(aq)} + \text{KOH(aq)} \rightarrow \text{CH}_3\text{COOK(aq)} + \text{H}_2\text{O(l)}$   
c)  $2\text{CH}_3\text{CO}_2\text{H(aq)} + \text{PbCO}_3\text{(s)} \rightarrow 2(\text{CH}_3\text{COO})_2\text{Pb(aq)} + \text{CO}_2\text{(g)}$

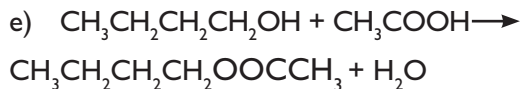
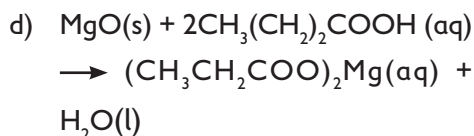
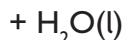

3. Molecular formula:

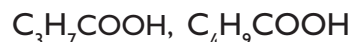

Structural formula:

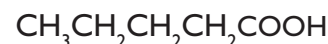

4. It is only partly ionised in solution.

5. Ethanoic acid forms many hydrogen(H) bond increasing strengths of molecular bonds.

6. Methanol + ethanoic acid  $\rightarrow$  methylethanoate + water

7.  $2\text{Na(s)} + 2\text{CH}_3\text{COOH(aq)} \rightarrow 2(\text{CH}_3\text{COO})\text{Na(aq)} + \text{H}_2\text{(g)}$

8.  $\text{HCOOCH}_3 + \text{H}_2\text{O} \rightarrow$

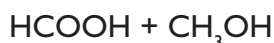

### Summary of the unit

This unit deals with carboxylic acids. Therefore, effectively use the practical activities and the suggested teaching approaches to guide learners in acquiring the requisite knowledge and desired competences in these areas. At the end of the lessons, you should assess the extent to which the competencies have been achieved and attitude change towards responsible use of natural

resources as a way of conserving our environment. Plan remedial activities where necessary for slow learners and give extra activities for gifted ones as well. Also, emphasise the fact that taking this unit seriously may lead to careers such as medicine, and analytical chemistry.

## **Additional Information for the teacher**

### **Sources of carboxylic acid**

The chief chemical characteristic of the carboxylic acids is their acidity. They are generally more acidic than other organic compounds containing hydroxyl groups but are generally weaker than the familiar mineral acids (e.g., hydrochloric acid, HCl, sulfuric acid, H<sub>2</sub>SO<sub>4</sub>, etc.).

Carboxylic acids occur widely in nature. The fatty acids are components of glycerides, which in turn are components of fat. Hydroxyl acids, such as lactic acid (found in sour-milk products) and citric acid (found in citrus fruits), and many keto acids are important metabolic products that exist in most living cells. Proteins are made up of amino acids, which also contain carboxyl groups.

Compounds in which the -OH of the carboxyl group is replaced by certain other groups are called carboxylic acid derivatives, the most important of which are acyl halides, acid anhydrides, esters, and amides.

### **Application of carboxylic acid**

Carboxylic acid derivatives have varied applications. For example, in addition to its use as a disinfectant, formic acid, the simplest carboxylic acid, is employed in textile treatment and as an acid reducing agent. Acetic acid is extensively used in the production of cellulose plastics and esters. Aspirin, the ester of salicylic acid, is prepared from acetic acid. Palmitic acid and stearic acid are important in the manufacture of soaps, cosmetics, pharmaceuticals, candles, and protective coatings. Stearic acid also is used in rubber manufacture. Acrylic acid is employed as an ester in the production of polymers (long-chain molecules) known as acrylates. Methacrylic acid serves as an ester and is polymerized to form Lucite. Oleic acid is used in the manufacture of soaps and detergents and of textiles.

### **Naming of carboxylic acids**

Salts of carboxylic acids are named in the same manner as are the salts of inorganic compounds; the cation is named first and then the anion, when writing the salt, but in writing the formula is reversed, as in sodium chloride. For carboxylic acids, the name of the anion is derived by changing the ending -oic acid of the IUPAC name or -ic acid of the common name to -ate. Some examples are sodium acetate, CH<sub>3</sub>COONa; ammonium formate, HCOONH<sub>4</sub>; and potassium butanoate (potassium butyrate), CH<sub>3</sub>CH<sub>2</sub>CH<sub>2</sub>COOK.

Acetic acid (CH<sub>3</sub>COOH) has been

known to human kind for thousands of years (at least in water solution). It is the compound that gives the sourness to vinegar and is produced by the bacterial oxidation of ethanol in wine. Household vinegar contains about five percent acetic acid. Acetic acid is important in the metabolic processes in humans and, indeed, of all animals and plants.

## The reactions of carboxylic acids

Carboxylic acids react in the same way as dilute mineral acids.

### 1. The reaction of carboxylic acids with alkalis

Carboxylic acids are neutralised by alkalis, for example

methanoic acid + sodium hydroxide → sodium methanoate + water.

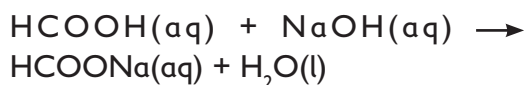

Ethanoic acid + potassium hydroxide → potassium ethanoate + water.

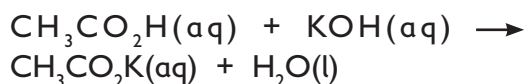

### 2. The reaction of carboxylic acids with carbonates

Carboxylic acids are neutralised by carbonates, for example

Ethanoic acid + sodium carbonate → sodium ethanoate + carbon dioxide +

water.

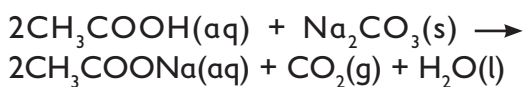

butanoic acid + zinc carbonate → zinc butanoate + carbon dioxide + water.

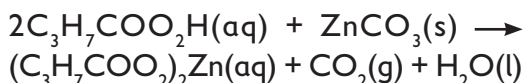

### 3. The reaction of carboxylic acids with metals

- Magnesium + ethanoic acid → magnesium ethanoate + hydrogen

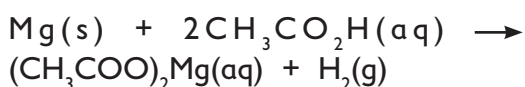

- Zinc + propanoic acid → zinc propanoate + hydrogen

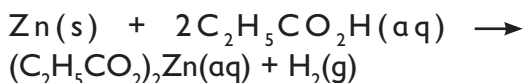

### 4. The reaction of carboxylic acids with alcohols

Carboxylic acids will react with alcohols to form esters.

### End of unit assessment

This section is divided into two parts:

- Answers to Test your Competence 10
- Additional exercises for unit assessment (consolidation exercise)

## a) Answers to Test your Competence 10

Refer to Learner's Book

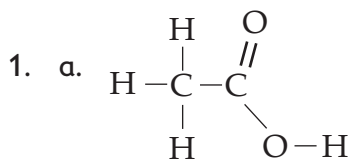

b. Carboxylic acids are organic acids. They do not completely give out hydrogen ions and they are partially ionised.

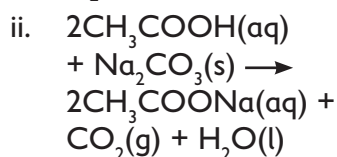
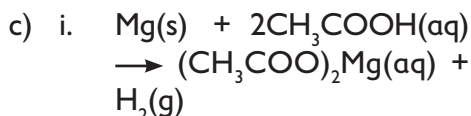

d) i. Potassium manganate (VII)  
ii. Acidification in excess

2. i. A reaction of an alcohol with an acid to produce an ester and water.

ii. The alkaline hydrolysis of fatty acid to form soaps.

3. It is partially ionised in solution.

4. a. Ionizes completely in solution

b. Sodium carbonate

c. Ethyl ethanoate, an ester

d. sodium ethanoate,  $\text{CH}_3\text{COONa}$

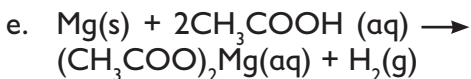

5. a. B - Ethanol -  $\text{CH}_3\text{CH}_2\text{OH}$

C - Hydrogen

D - Ethylethanoate -  $\text{CH}_3\text{COOCH}_2\text{CH}_3$

E-Dibromoethane

$\text{CH}_2\text{BrCH}_2\text{Br}$

b. F- Conc. phosphoric acid

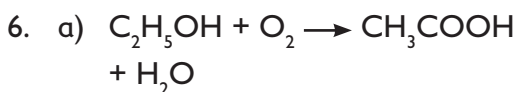

b) Become acidic.

c) The body contains buffering agents that prevent a weak acid from adversely affecting the acidity of your tissues. You can tolerate vinegar without any ill effects.

7. a. Refer to student's book table 10.1

b.  $-\text{COOH}$

8. a. Neutralisation; - salt and water formed

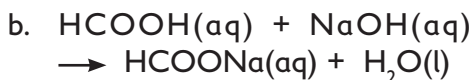

c. Ester

9. a)  $\text{CH}_3\text{OH}$

b)  $\text{CH}_3\text{COOCH}_3 + \text{H}_2\text{O(l)}$

c)  $\text{CH}_3\text{COOCH}_2\text{CH}_3 + \text{H}_2\text{O}$

d)  $\text{CH}_3\text{COONa} + \text{H}_2\text{O(l)}$

e)  $\text{CH}_3\text{COONa} + \text{CO}_2 + \text{H}_2\text{O}$

f)  $\text{CH}_3\text{COONa} + \text{H}_2(\text{g})$

10. Making vinegar, laboratory reagent, preparation of dyes, perfumes and medicine.

### (b) Additional end of unit assessment questions (consolidation exercises)

1. Why is ethanoic acid called glacial acetic acid?

**Ans.** On cooling, pure ethanoic acid is frozen to form ice like flakes. They look like glaciers, so it is called glacial acetic acid.

2. Ethanoic acid ( $\text{CH}_3\text{COOH}$ ) is a typical weak acid.

(a) What is a weak acid?

**Ans:** A weak acid is one that partially dissociates to give hydrogen ions as the only positively charged ions.

(b) Describe ways in which ethanoic acid differs from a strong acid such as sulphuric acid.

**Ans:** A strong acid completely dissociates while a weak acid undergoes partial dissociation.

3. Ethanoic acid can be made in the laboratory by the oxidation of ethanol with potassium dichromate.

(a) Name another oxidising agent that can be used to oxidise ethanol.

**Ans:** Potassium dichromate or potassium manganate (VII) solution.

(b) What conditions are required for this oxidation?

**Ans:** Presence of an acid or hydrogen ( $\text{H}^+$  ions).

4. Write down the word and chemical

equations for the reaction between ethanol and ethanoic acid.  
Ans

Ethanoic acid + Ethanol  
Ethylethanoate + Water

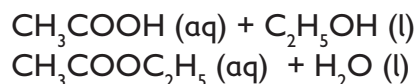

5. What is saponification?

**Ans.** It is the alkaline hydrolysis of esters to give back the carboxylic acid and alcohol. Because it is used in the preparation of soap, it is called saponification.

6. When acetic acid reacts with substance X, a salt is formed which on reaction with soda lime gives a gas Y. Write the chemical equations that take place and identify X and Y.

**Ans:**

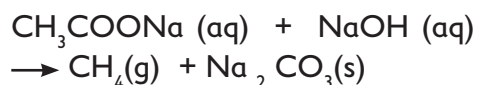
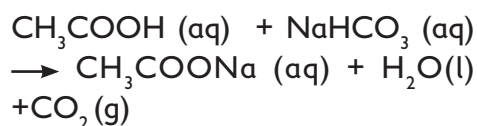

Therefore, X – sodium hydrogen carbonate; Y – Methane gas(b)

## Extended and remedial exercises

Remedial activities for slow learners	Extended activities for gifted and talented learners
<ol style="list-style-type: none"><li>1. Collecting, cleaning and arranging apparatus and reagents in the laboratory.</li><li>2. Collect various materials and objects at home for experiments.</li><li>3. Drawing diagrams from charts on their note books</li></ol> <p><b>Low order thinking (LOT) questions for slow learners</b></p> <ol style="list-style-type: none"><li>1. What is the general formula of carboxylic acids?</li><li>2. Give the name of a carboxylic acid with 6 carbons.</li></ol> <p><b>Answers Low order thinking questions</b></p> <ol style="list-style-type: none"><li>1. R-COOH</li><li>2. Hexanoic acid</li></ol>	<ol style="list-style-type: none"><li>1. Do further research in textbooks or the internet about carbon and its inorganic compounds. Write short notes then share with other class members.</li><li>2. Set up experimental apparatus for practicals in the laboratory.</li><li>3. Come up with a project for making dyes from carboxylic acid. Use locally available materials and make the item.</li></ol> <p><b>High order thinking (HOT) questions for gifted learners</b></p> <ol style="list-style-type: none"><li>1. Comment about the solubility of carboxylic acids.</li><li>2. Describe the process of esterification.</li></ol> <p><b>Answers to high order thinking questions</b></p> <ol style="list-style-type: none"><li>1. It generally decreases with increasing molecular mass.</li><li>2. The hydroxyl group from the acid combines with the hydrogen atom from hydroxyl group of alcohol to form water and the remaining parts combine.</li></ol>

**Refer to student's book****Key Unit Competence**

After studying this unit, the learner should be able to explain the origin of petroleum products and applications of polymers.

**Learning objectives**

Competency based curriculum embraces three categories of learning objectives, that is, knowledge and understanding,

skills acquisition and attitude and values. At the end of the unit, learners should have knowledge and understanding of the origin of petroleum product and applications of polymer. Appreciate the importance of polymers and petroleum products in everyday life as a source of revenues through taxes and as fuels in some countries.

**Table 11.1: Knowledge, skills and values to be attained**

Knowledge and understanding	Skills	Attitudes and values
<ul style="list-style-type: none"> <li><input type="checkbox"/> State the origin of crude oil.</li> <li><input type="checkbox"/> Describe the process of fractional distillation of crude oil.</li> <li><input type="checkbox"/> Define polymerisation and give examples of synthetic and natural polymers.</li> <li><input type="checkbox"/> Describe uses of polymers in daily life.</li> </ul>	<ul style="list-style-type: none"> <li><input type="checkbox"/> Observation skills.</li> <li><input type="checkbox"/> Manipulation of equipment.</li> <li><input type="checkbox"/> Research and presentation skills.</li> <li><input type="checkbox"/> Classify polymers as natural or synthetic polymers.</li> </ul>	<ul style="list-style-type: none"> <li><input type="checkbox"/> Develop culture of entrepreneurship.</li> <li><input type="checkbox"/> Develop a culture of working in a team.</li> <li><input type="checkbox"/> Develop orderliness in presentation and experiment.</li> <li><input type="checkbox"/> Respect for the procedures of an experiment.</li> <li><input type="checkbox"/> Appreciate the uses and dangers associated with polymers in daily life.</li> <li><input type="checkbox"/> Develop Self- confidence in presentations and discussions.</li> </ul>

## **Links to other subjects**

During the lessons, strive to bring to the attention of learners the fact that this topic is related to environment and sustainability in Geography and in General studies at advanced level of learning.

## **Background Information**

Polymer' comes from the Greek, meaning 'many parts.' A polymer is a long molecule consisting of many identical or similar building blocks linked by covalent bonds - like how a train consists of a chain of wagons. Most large molecules, or macromolecules, are polymers. The repeating units that serve as the building blocks of a polymer are small molecules called monomers.

How are these monomers put together? Polymerisation is the process of connecting these monomers together and creating large macromolecules of different sizes and shapes. Polymerisation is similar to constructing a large building out of the same type of Lego blocks. The blocks can be connected in various ways to create a larger, more intricately shaped structure than the original Lego block on its own.

## **Cross-cutting issues to be addressed**

### **1. Inclusive learning**

All categories of learners should be encouraged to participate during lessons and practical experiments. Make arrangement to take care of learners with special needs. In particular learners

with visual impairment should be placed in front of the classroom. Provide braille for learners with visual impairment and large print text for those with sight problems.

Group physically challenged learners with the rest to assist them during movement and field trips and other practical activities. Furthermore, give these learners tasks they can manage comfortably during practical.

### **2. Gender education**

Both boys and girls should participate equally in all activities. Emphasise to learners that anybody irrespective of their gender can pursue a career in this chemistry field. Give examples of role models who are successful in the careers locally.

### **3. Financial education**

Petroleum products are used as fuel and as raw materials during the manufacturing process. All these have financial implications in terms of cost.

### **4. Standardisation culture**

Emphasise the need to use chemicals and apparatus certified by the Rwanda standard board.

### **5. Environment and sustainability education**

Bring to the attention of learners the fact that petroleum products and waste products are linked to global warming and harmful to human health of the environment.



## 6. Peace and values education

Emphasise to learners the importance of working harmoniously with each other during group work and class activities.

## 7. Health education

Emphasise to learners that some petroleum products are dangerous to organisms' life.

### Generic competencies

#### 1. Research skills

Guide learners on how to find information regarding various topics, on how to come up with summarised notes from a large body of text and on how to do internet searches for the various content areas they are looking for.

#### 2. Communication in English

Communication in English will be improved when learners freely participate in the discussions and presentations. Encourage all learners irrespective of their abilities to participate in group discussions, during presentations by asking questions and during question and answer sessions to either introduce or wrap up the lessons.

#### 3. Cooperation and interpersonal management and life skills

During group discussions and pair-work let learners engage one another by giving a chance for all to participate. Also, during group presentations, you can allow rotational presentations within the group members. Gifted learners should help in coming up with presentation content as slow learners contribute.

## 4. Critical thinking and problem solving skills

This competence will be developed by learners as they answer the probing questions at the beginning of this unit and as they discuss the results of the various practical activities. Guide learners to discover for themselves information about petroleum products and polymers. This competence will also come about as learners think about their findings during the activities and as they give out their suggestions.

## 5. Lifelong learning skills

Good environmental management and realising the importance of natural resources builds the economy of a country.

### Key words in this unit and their meanings

- **Fractional distillation** – the process of separation of mixtures which are miscible to each other basing on their differences on their boiling points.
- **Fossil fuel** – a natural fuel such as coal or gas, formed in the geological past from the remains of living organisms.
- **Cracking** – breaking down of large molecules in small molecules by using heat or catalyst.
- **Polymer** – A polymer is a long molecule consisting of many identical or similar building blocks linked by covalent bonds.
- **Monomer** – The repeating units that serve as the building blocks of a polymer are small molecules called monomers.

- ❑ **Polymerisation** – process by which small molecules called monomers combine to form large molecules called polymers.
- ❑ **Addition polymerisation** – Polymerisation that occurs through the coupling of monomers using their multiple bonds.
- ❑ **Condensation polymerisation** – Monomers are connected by a reaction in which two molecules are covalently bonded to each other through loss of a water molecule.

**Guidance on the brain teaser**

This topic is about the petroleum products and polymerisation. As a way of introducing these concepts, refer learners to the pictures in Learner’s

Book. The pictures show a variety of products formed from petroleum products and polymerisation. Allow learners in groups to discuss the use and application of petroleum products. The groups should be constituted based on learner abilities and class size. Let them give answers to the probing questions associated with the pictures.

Guide the learners to discover what they will learn in this topic. Further, emphasise the need for taking this topic seriously in the course of the lessons as it can lead to careers such as analytical chemistry, geology and mining.

**Attention to special educational needs**

<b>Support for multi ability learning</b>	<b>Support for special needs learning</b>
<ul style="list-style-type: none"> <li>❑ Gifted learners to research on the extraction of crude oil and its refining at the oil refinery.</li> <li>❑ Both gifted and progressive gradual learners to be given equal opportunity to lead in group discussions and to do presentations of group findings to the rest of the class.</li> <li>❑ Ensure all learners respect each other’s views irrespective of their shortcomings or talents.</li> </ul>	<ul style="list-style-type: none"> <li>❑ Allocate gifted learners to help fellow learners with special needs.</li> <li>❑ Provide brail for the blind and large print text to learners with seeing difficulties. Provide sign language alphabet symbols and sign language interpreters for the deaf.</li> <li>❑ Also, arrange learners such that shortsighted ones are at the front and long-sighted ones are at the back. Spectacles can as well be provided if available for learners with seeing difficulties.</li> </ul>

## List of lessons

Lesson No.	Lesson title	No. of periods
1	Origin of crude oil and its fractional distillation	3
2.	Polymers and polymerisation	4
3	Dangers associated with use of polymers	2
4	End of unit assessment test	1

### 11.1 Origin of crude oil and its fractional distillation

Refer to Learner's book

#### Lesson 1: Origin of crude oil and its fractional distillation (To be covered in three periods)

##### Specific objectives

By the end of the lesson, learners should be able to:

- State the origin of crude oil.
- Describe the process of fractional distillation of crude oil.

##### Preparation for the lesson

1. This lesson will involve a research activity either in the library or using the internet or group work.
2. Discussion and presentation of research work.
3. Also, ensure that the internet is working if you have a computer laboratory or any other form of internet connectivity such as WIFI or modem.
4. The teacher should guide the learners on how to access the relevant information using Google, books or any written pamphlets.

##### Suggested teaching aids

- Charts with fractional distillation of crude petroleum and their products.
- Video link to the learners about fractional distillation.

##### Pre-requisite to the lesson

Introduce the unit as explained under guidance on the problem statement above then narrow down to the lesson.

##### Suggested teaching and learning activities

1. Begin the lesson by asking learners probing questions about petroleum products and polymerisation such as:
  - What is the origin of the hydrocarbons?
  - Why do we have different types of fuel i.e. petrol, oil, diesel, jet fuel, kerosene yet all come from same raw material: Crude oil? How are they obtained?
  - How are plastics formed?
2. From their responses introduce Activities 11.1 and 11.2 in Learner's Book . These are group activities intended to bring out the idea of origin of crude oil and fractional distillation of crude oil.

- Let learners do research on the origin of crude oil, write a report and share their findings with the rest of the class.
- Build on their findings to explain the origin of crude oil as outlined in the Learner's Book.
- Provide learners with charts on crude oil, diagrams and computer animations having fractional distillation to help them carry out activity 11.2 in the Learner's Book.
- In their respective groups let learners have a brief discussion session on their findings then write summary notes. Correct them as is appropriate.
- End the lesson by instructing learners to attempt self-evaluation Test 11.1.

### Synthesis

The lesson introduces learners to the origin of crude oil and fractional distillation of its products. The activities carried out during the lesson should help learners find out the origin of crude oil and its components and how they are separated by fractional distillation.

### Lesson assessment

Assess whether the learning objectives of the lesson were met by asking questions such as:

- How does crude oil come about?
- What is fractional distillation of crude oil?
- Why is fractional distillation preferably used in this process?

- What is cracking?
- Identify different components of crude oil and name their uses.

### Answers to Self-evaluation Test 11.1

*Refer to Learner's Book*

- It was formed from the remains of living organisms.
- To get the various useful fractions.
  - The fractions have different boiling points.
  - Fractional distillation is an important method of separating complex mixtures. It relies on the principle that different substances have different boiling points. Check for correct diagram.
- Increase in molecular weight increases the boiling point due to occurrence of many more hydrogen bonds.

### 11.2 Polymers and polymerisation

*Refer to Learner's Book*

#### Lesson 2: Polymers and polymerisation (To be covered in four periods)

#### Specific objectives

By the end of the lesson, learners should be able to:

- Define the term polymerisation and state different types of polymerisation.

- Define addition polymerisation and their uses.
- Define condensation polymerisation and their uses.
- Describe how condensation polymers are formed and give examples.
- Explain the advantages and disadvantages of using polymers.

### Preparation for the lesson

1. This lesson will involve a field visit and research activity either in the library or using the internet.
2. Discussion and presentation of researched work.
3. Organise for a field visit to a local plastic factory or methane gas plant nearby.
4. The teacher should guide the learners how to access the relevant information using Google, books or any written pamphlets.

### Suggested teaching aids

- Charts showing natural polymers and fibers, addition polymers and condensation polymers.
- Video link to the learners about polymerisation and polymers for ordinary level students or you can carry a downloaded video on your memory stick to avoid inconveniences of network shortage.
- Chalkboard diagrams
- Learner's Book

### Suggested teaching and learning activities

1. This lesson will best be taught by taking learners to a plastic making factory first, where they will be introduced to polymers and polymerisation in its application in industry. You can also opt for a production plant in the locality.
2. Let learners prepare for the field study as suggested in Activity 11.3 in the Learner's Book. Instruct learners to write a report and present it in class.
3. Build on their presentations to explain polymers and polymerisation. Use notes in the Learner's Book to explain polymerisation. Start by discussing the types of polymers: natural and artificial and their examples as learners take notes.
4. Thereafter explain additional polymerisation using diagrams and charts. Bring to learners' attention Table 11.2 giving a summary of polymers formed. Using specific example write equation to show how condensation and additional polymers are formed.
5. Then explain condensation polymerisation, tell learners the difference from additional polymerisation using diagrams. Bring to learners attention table 11.3 on properties and uses of synthetic polymers. Use synthetic rubber to compare it with the natural rubber to establish any differences.

6. Brainstorm with learners the natural polymers found in nature such as proteins, lipids and carbohydrates as they write notes.
  7. Help learners to summarise the lesson by writing short notes on polymerisation.
  8. End the lesson by instructing learners to attempt self-evaluation test 11.2.
3. a) The process of joining together a large number of small molecules to make a chain of large molecules.  
b) i. One  
ii. Many
  4. This is because many monomers can join together to form a giant polymer.

5. (i) Addition polymerisation  
(ii) Refer to Learner's Book.

### Synthesis

This lesson introduces learners to polymerisation. Guide learners through research and discussion to discover advantage and disadvantage of polymers and their uses.

### Lesson assessment

Assess whether the learning objectives of the lesson were met by asking questions such as:

1. Define polymer and polymerisation?
2. State different types of polymers giving one example in each case.
3. What is addition polymerisation? Give examples.
4. Using equations show the difference between addition and condensation polymerisation.

### Answers to Self-evaluation Test

#### 11.2

*Refer to Learner's Book*

1. Additional and condensation polymerisation.
2. Refer to Learner's Book.

## 11.3 Dangers associated with polymers

### Lesson 3: Dangers associated with polymers (To be covered in two periods)

*Refer to Learner's Book*

#### Specific objectives

By the end of the lesson, learners should be able to:

- Appreciate the uses and dangers associated with polymers in daily life.
- Carry out research on protection of the environment and hence protect natural resources.

#### Preparation for the lesson

1. This lesson will be taught in two periods and will involve group work, research work and note taking. You should therefore organise the class. The learners should be organised in the class in a way that suits discussion, research work and presentations.

- Bring charts on dangers of polymers on the environment and textbooks for reference in the laboratory.

**Note:** When placing learners in groups you should consider the different abilities of learners and the special needs of various individuals.

### Suggested teaching aids

- Charts on the effects of petroleum products and polymerisation on the environment.
- Video on the effects of petroleum products and polymerisation on the environment.
- Learner's Book

### Pre-requisite to the lesson

Environmental pollution is a major problem. Let learners be aware that most of the artificial polymers are a major contributor to environment pollution.

### Suggested teaching and learning activities

- Organise learners into convenient groups to carry out research activity suggested in the Learner's Book.
- Instruct them to note down their findings which they will discuss and present to the rest of the class. Build on their findings to explain the dangers associated with polymers on the environment as outlined in the learner's book as they take notes.

- Summarise the lesson by bringing out the key points on the effects of dangers associated with polymers on the environment
- End the topic by instructing learners to attempt self-evaluation 11.3 and Test your Competence 11.

### Synthesis

This lesson introduces learners to the dangers associated with polymers to the environment. Let learners be aware of the need for environmental conservation.

### Answer to self-evaluation test I I

*Refer to learners book*

- (i)

Advantages	Disadvantages
• Have a good elasticity.	• Require careful ironing.
• Do not wrinkle easily.	
• Can handle heavy loads	

- (ii)

Advantages	Disadvantages
• Comfortable.	• Lack mechanical strength
• Less harmful to environment.	• Expensive

• Resistant to fire.	• Shrinks
----------------------	-----------

- Biodegradable material decompose while non-biodegradable materials do not decompose.
- Biodegradable - Food and paper waste, human waste, sewage waste.  
Non-biodegradable - plastic, cans, bottles, metal scraps, glasses.
- Pollution
- Burning
  - Burying
  - Recycling
  - Reuse

### Suggested lesson assessment

Assess whether the learning objectives of the lesson were achieved by asking questions such as:

- How can we reduce the dangers associated with polymers to the environment?

*Ans: Minimise usage of polymers or find alternatives.*

### Summary of the unit

This unit deals with petroleum products and polymerisation. Guide learners using the activities suggested in the unit. Make them appreciate the uses and dangers associated with polymers in daily life instil the skills of observation, manipulation of equipment, research and presentation in the learners.

Develop the culture of entrepreneurship in the learners as you teach this unit.

### Additional Information for the teacher

In polymer chemistry, polymerisation is a process of reacting monomer molecules together in a chemical reaction to form polymer chains or three-dimensional networks.

Polymerisation reaction is of two types: addition polymerisation: in which monomers simply join together to form a polymer. Condensation polymerisation: in which the loss of some small molecule (like  $H_2O$ ) also takes place during the addition of monomers to form a polymer

When many molecules of a simple compound join together, the product is termed a polymer and the process polymerisation. The simple compounds whose molecules join together to form the polymers are called monomers. The polymer is a chain of atoms, providing a backbone, to which atoms or groups of atoms are joined.

The chemical reaction in which high molecular mass molecules are formed from monomers is known as polymerisation. There are two basic types of polymerisation, chain-reaction (or addition) and step-reaction (or condensation) polymerisation.

Condensation polymers are any kind of polymers formed through a condensation reaction—where molecules join together—losing small molecules as byproducts such as water



or methanol, as opposed to addition polymers which involve the reaction of unsaturated monomers.

The back bones of common synthetic polymers such as polythene, polystyrene and poly acrylates are made up of carbon-carbon bonds, whereas hetero chain polymers such as polyamides, polyesters, polyurethanes, polysulfides and polycarbonates have other elements (e.g. oxygen, sulfur, nitrogen) inserted along the backbone.

They are often water-based. Examples of naturally occurring polymers are silk, wool, DNA, cellulose and proteins. In our previous section on network polymers, we mentioned vulcanized rubber and pectin. Vulcanized rubber is a synthetic (man-made) polymer, while pectin is an example of a natural polymer.

### End of unit assessment

This section is divided into two parts

- Answers to test your competence 11
- Additional exercise for unit assessment.

#### a) Answers to Test your competency I I

Refer to Learner's Book

1. a. Refer to learner book.  
b. i. Polyethenes, polypropylene, PVC, Teflon  
ii. Polyester, Dacron and the polyamide Nylon- 6,6.
2. Monomer: a relatively light, simple organic molecule that can join in

long chains with other molecules to form a more complex molecule called polymer.

**Polymer:** a natural or synthetic compound that consists of large molecules made of many chemically bonded smaller identical molecules.

3. a) The process of joining monomers to form a large molecule. The monomer molecule is unsaturated (i.e. contain double bonds or triple bonds).  
b) A part of a polymer whose repetition would produce the complete polymer chain.  
c) They are used in industries to make various products we use e.g polythene bags, PVC pipes.
4. a) Reduce, reuse and recycle  
b) They do not decompose  
c) Leads to air pollution
5. a) Fractional distillation  
b) A – Natural gas  
B – Petrol  
C – Kerosene  
D - Diesel  
E – Fuel  
F – Lubricants oil  
c) They have different densities  
d) Molecular weight  
e) Gasoline
6. a)  $\text{CH}_2=\text{CHCl}$   
b) Chloroethene (vinyl chloride)

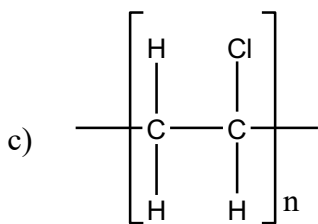

d) Addition polymerisation

7. i.  $\text{CH}_3\text{OH}$   
 ii.  $\text{HCOOH}$   
 iii. Methylmethanoate,  $\text{HCOOCH}_3$
8. a. 2-methylpropene

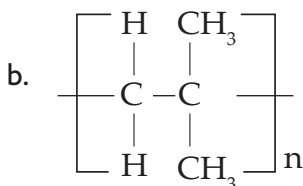

c. Addition

- |       |       |
|-------|-------|
| 9. C  | 10. A |
| 11. B | 12. A |
| 13. A | 14. C |
| 15. B | 16. A |
| 17. A | 18. A |
| 19. C | 20. B |
| 21. D | 22. D |

**(b) Additional exercise for end of unit assessment (Consolidation exercises)**

**Fill in the spaces provided below using the words given**

*Macromolecules, chain, monomers, Large, smaller, alkenes. Polymerization. Wide range, structure, made from*

Polymers are very \_\_\_\_\_ molecules (sometimes called \_\_\_\_\_).

Each polymer molecule is a long \_\_\_\_\_ of (mainly carbon) atoms. Polymers are made from many \_\_\_\_\_ molecules, called \_\_\_\_\_.

These monomers (the starting materials) are often \_\_\_\_\_. The process (chemical reaction) that turns monomers into polymers is called \_\_\_\_\_. The conditions necessary for polymerisation are heat, pressure and a catalyst.

Polymers produce a very \_\_\_\_\_ of materials with many uses. New materials are often used to replace older ones because the new material has superior properties. The properties of the material depend on what the polymer is \_\_\_\_\_ and its \_\_\_\_\_.

**Answers remedial questions for slow learners**

Polymers are very **large** molecules (sometimes called **macromolecules**). Each polymer molecule is a long **chain** of (mainly carbon) atoms. Polymers are made from many **smaller** molecules, called **monomers**.

These monomers (the starting materials) are often **alkenes**. The process (chemical reaction) that turns monomers into polymers is called **polymerisation**. The conditions used for polymerisation are heat, pressure and a catalyst. Polymers produce a very **wide range** of materials with many uses.

New materials are often used to replace older ones because the new material has superior properties. The properties of the material depend on what the polymer is **made from** and its **structure**.

### Extended and remedial exercises

Remedial activities for slow learners	Extended activities for gifted and talented learners
<p><b>Low order thinking (LOT) questions for slow learners</b></p> <ol style="list-style-type: none"> <li>1. What is cracking?</li> <li>2. Name examples of natural polymers.</li> </ol> <p><b>Answers Low order thinking questions</b></p> <ol style="list-style-type: none"> <li>1. The heating of less used fractions (large chain alkanes) to make small chain products which are very useful i.e on high market demand.</li> <li>2. Starch, cellulose, proteins, glycogen, fats and rubber.</li> </ol>	<p><b>High order thinking (HOT) questions for gifted learners</b></p> <ol style="list-style-type: none"> <li>1. What is the meaning of biodegradable plastics?</li> <li>2. Differentiate between natural and artificial polymers.</li> </ol> <p><b>Answers to high order thinking questions</b></p> <ol style="list-style-type: none"> <li>1. These are plastics that can decompose.</li> <li>2. Natural polymers have their origin in plants and animals while synthetic are man-made.</li> </ol>

## Appendices

### Appendix I

Atomic numbers and relative atomic masses of some elements

Element	Symbol	Atomic number	Relative atomic mass
Aluminium	Al	13	27
Argon	Ar	18	40
Barium	Ba	56	127
Beryllium	Be	4	9
Boron	B	5	11
Bromine	Br	35	80
Calcium	Ca	20	40
Carbon	C	6	12
Chlorine	Cl	17	35.5
Chromium	Cr	24	52
Copper	Cu	29	64
Flourine	F	9	19
Gold	Au	79	197
Helium	He	2	4
Hydrogen	H	1	1
Iodine	I	53	127
Iron	Fe	26	56
Krypton	Kr	36	84
Lead	Pb	82	207
Lithium	Li	3	7
Magnesium	Mg	12	24
Manganese	Mn	25	55
Mercury	Hg	80	200
Neon	Ne	10	20
Nickel	Ni	28	59
Nitrogen	N	7	14

Oxygen	O	8	16
Phosphorous	P	15	31
Potassium	K	19	39
Silicon	Si	14	28
Silver	Ag	47	108
Sodium	Na	11	23
Sulphur	S	16	32
Tin	Sn	50	119
Vanadium	V	23	51
Zinc	Zn	30	65

## **Appendix II**

Valencies of some of the elements in the periodic table

<b>Name of metal</b>	<b>Symbol</b>	<b>Valency</b>
Zinc	Zn	2
Iron	Fe	2 or 3
Tin	Sn	4
Lead	Pb	2
Copper	Cu	1 or 2
Silver	Ag	1
Barium	Ba	2
Phosphorus	P	3 or 5

### Appendix III

Valencies of some common radicals

Valency 1		Valency 2		Valency 3	
Radical	Formula	Radical		Radical	Formula
Ammonium	$\text{NH}_4^+$	Carbonate	$\text{CO}_3^{2-}$	Phosphate	$\text{PO}_4^{3-}$
Hydroxide	$\text{OH}^-$	Sulphate	$\text{SO}_4^{2-}$		
Nitrate	$\text{NO}_3^-$	Sulphite	$\text{SO}_3^{2-}$		
Chloride	$\text{Cl}^-$				
Hydrogen carbonate	$\text{HCO}_3^-$				
Hydrogen sulphide	$\text{HSO}_4^-$				

### Appendix IV

Valencies of some elements in some compounds

Compound	Element	Valency
Copper(I) oxide	Copper	1
Copper(II) oxide	Copper	2
Iron(II) sulphate	Iron	2
Iron(III) chloride	Iron	3
Sulphur(IV) oxide	Sulphur	4
Sulphur(VI) oxide	Sulphur	6
Carbon(IV) oxide	Carbon	4
Carbon(II) oxide	Carbon	2

# Periodic Table of Elements

$x$  is the Relative Atomic Mass (RAM)  
 $Z$  is the symbol of the element  
 $y$  is the Atomic number of the element

$x$	$Z$
$y$	Name

Periods	Groups		I	II	III	IV	V	VI	VII	O
		1	2	1	2	3	4	5	6	7
1	1 H Hydrogen									4 He Helium
2	3 Li Lithium	4 Be Beryllium							9 F Fluorine	10 Ne Neon
3	11 Na Sodium	12 Mg Magnesium							17 Cl Chlorine	18 Ar Argon
4	19 K Potassium	20 Ca Calcium							35 Br Bromine	36 Kr Krypton
5	37 Rb Rubidium	38 Sr Strontium							53 I Iodine	54 Xe Xenon
6	55 Cs Cesium	56 Ba Barium							83 Bi Bismuth	84 Po Polonium
7	87 Fr Francium	88 Ra Radium							115 Uut Ununpentium	116 Uuq Ununquadium
										117 Uus Ununseptium
										118 Uuo Ununoctium

←	→	←
Transition metals		

←	→	←
Lanthanides		

←	→	←
Actinides		